



SP690T/S/R, SP802T/S/R, SP804T/S/R, and SP805T/S/R

3.0V/3.3V Low Power Microprocessor Supervisory with Battery Switch-Over

- $\overline{\text{RESET}}$ and RESET Outputs
- Reset asserted down to $V_{CC} = 1V$
- Reset Time Delay - 200ms
- Watchdog Timer - 1.6 sec timeout
- **40 μ A Maximum V_{CC} Supply Current**
- **1 μ A Maximum Battery Supply Current**
- **Power Switching**
 - 50mA Output in V_{CC} Mode (1.5 Ω)**
 - 10mA Output in Battery Mode (15 Ω)**
- Battery Can Exceed V_{CC} in Normal Operation
- Precision Voltage Monitor for Power-Fail or Low-Battery Warning
- Available in 8 pin SO and DIP packages
- Pin Compatible Upgrades to
MAX690T/S/R, MAX802T/S/R,
MAX804T/S/R, MAX805T/S/R



DESCRIPTION

The **SP690T/S/R, SP802T/S/R, SP804T/S/R** and **SP805T/S/R** devices are a family of microprocessor (μ P) supervisory circuits that integrate a myriad of components involved in discrete solutions to monitor power-supply and battery-control functions in μ P and digital systems. The series will significantly improve system reliability and operational efficiency when compared to discrete solutions. The features of the **SP690T/S/R, SP802T/S/R, SP804T/S/R** and **SP805T/S/R** devices include a watchdog timer, a μ P reset and backup-battery switchover, and power-failure warning; a complete μ P monitoring and watchdog solution. The series is ideal for 3.0V or 3.3V applications in portable electronics, computers, controllers, and intelligent instruments and is a solid match for designs where it is critical to monitor the power supply to the μ P and it's related digital components. Refer to **Sipex's SP690A/692A/802L/802M/805L/805M** series for similar devices designed for +5V systems.

Part Number	RESET Active	RESET Threshold	RESET Accuracy	PFI Accuracy	Watchdog Input	Backup-Battery Switch
SP690T/805T	LOW/HIGH	3.075V	$\pm 75mV$	$\pm 4\%$	YES	YES
SP802T/804T	LOW/HIGH	3.075V	$\pm 60mV$	$\pm 2\%$	YES	YES
SP690S/805S	LOW/HIGH	2.925V	$\pm 75mV$	$\pm 4\%$	YES	YES
SP802S/804S	LOW/HIGH	2.925V	$\pm 60mV$	$\pm 2\%$	YES	YES
SP690R/805R	LOW/HIGH	2.625V	$\pm 75mV$	$\pm 4\%$	YES	YES
SP802R/804R	LOW/HIGH	2.625V	$\pm 60mV$	$\pm 2\%$	YES	YES

www.BDTIC.com/Exar/

ABSOLUTE MAXIMUM RATINGS

These are stress ratings only and functional operation of the device at these ratings or any other above those indicated in the operation sections of the specifications below is not implied. Exposure to absolute maximum rating conditions for extended periods of time may affect reliability and cause permanent damage to the device.

V_{CC}	-0.3V to 6.0V
V_{BATT}	-0.3V to 6.0V
All Other Inputs (NOTE 1).....	-0.3V to the higher of V_{CC} or V_{BATT}
Continuous Input Current:	
V_{CC}	100mA
V_{BATT}	20mA
GND.....	20mA
WDI, PFI.....	20mA
Continuous Output Current:	
RESET, RESET, PFO.....	20mA
V_{OUT}	100mA
Power Dissipation per Package:	
8pin NSOIC (derate 6.14mW/°C above +70°C).....	500mW
8pin PDIP (derate 11.8mW/°C above +70°C).....	1,000mW
Storage Temperature.....	-65°C to +160°C
Lead Temperature(soldering,10sec).....	+300°C
ESD Rating.....	4KV Human Body Model



CAUTION:
ESD (ElectroStatic Discharge) sensitive device. Permanent damage may occur on unconnected devices subject to high energy electrostatic fields. Unused devices must be stored in conductive foam or shunts. Personnel should be properly grounded prior to handling this device. The protective foam should be discharged to the destination socket before devices are removed.

SPECIFICATIONS

$V_{CC} = 3.17V$ to $5.50V$ for the SP690T/SP80_T, $V_{CC} = 3.02V$ to $5.50V$ for the SP690S/SP80_S, $V_{CC} = 2.72V$ to $5.50V$ for the SP690R/SP80_R, $V_{BATT} = 3.60V$, and $T_A = T_{MIN}$ to T_{MAX} unless otherwise noted. Typical values taken at $T_{AMB} = +25^{\circ}C$.

PARAMETERS	MIN.	TYP.	MAX.	UNITS	CONDITIONS
Operating Voltage Range, V_{CC} or $V_{BATTERY}$, NOTE 1	1.0		5.5	Volts	
V_{CC} Supply Current, I_{SUPPLY}		25	40	μA	excluding I_{OUT}
V_{CC} Supply Current in Battery Backup Mode		20	40	μA	$V_{CC}=2.0V, V_{BATTERY}=2.3V$, excluding I_{OUT}
$V_{BATTERY}$ Supply Current in Any Mode, NOTE 2		0.4	1	μA	excluding I_{OUT}
$V_{BATTERY}$ Leakage Current, NOTE 3		0.001	0.5	μA	
$V_{BATTERY}$ Leakage Current, NOTE 4	-0.1		0.02	μA	$3.3V > V_{CC} > V_{BATTERY} + 0.2V$
Output Voltage, V_{OUT}	$V_{CC} - 0.03$ $V_{CC} - 0.3$ $V_{CC} - 0.0015$	$V_{CC} - 0.0075$ $V_{CC} - 0.075$ $V_{CC} - 0.0003$		V	$I = 5mA$ $I_{OUT} = 50mA$ $I_{OUT} = 250\mu A, V_{CC} > 2.5V$
V_{OUT} in Battery-Backup Mode	$V_{BATTERY} - 0.02$	$V_{BATTERY} - 0.0045$ $V_{BATTERY} - 0.018$ $V_{BATTERY} - 0.15$		V	$I_{OUT} = 250\mu A, V_{BATTERY} = 2.3V$ $I_{OUT} = 1mA, V_{BATTERY} = 2.3V$ $I_{OUT} = 10mA, V_{BATTERY} = 3.3V$
Battery Switch Threshold, V_{CC} falling	0.065 2.30	0.025 2.40	2.50	V	$V_{BATTERY} - V_{CC}, V_{SW} > V_{CC} > 1.75V$, NOTE 5 $V_{BATTERY} > V_{CC}$, NOTE 6
Battery Switch Threshold, V_{CC} rising, NOTE 7				V	Values are identical to the Reset Threshold values at V_{CC} rising

SPECIFICATIONS (continued)

$V_{CC} = 3.17V$ to $5.50V$ for the SP690T/SP80_T, $V_{CC} = 3.02V$ to $5.50V$ for the SP690S/SP80_S, $V_{CC} = 2.72V$ to $5.50V$ for the SP690R/SP80_R, $V_{BATT} = 3.60V$, and $T_A = T_{MIN}$ to T_{MAX} unless otherwise noted. Typical values taken at $T_{AMB} = +25^{\circ}C$.

PARAMETERS	MIN.	TYP.	MAX.	UNITS	CONDITIONS	
Reset Threshold, V_{RST} NOTE 8	3.00	3.075	3.15	V	SP690T/805T, V_{CC} falling	
	3.00	3.085	3.17		SP690T/805T, V_{CC} rising	
	2.85	2.925	3.00		SP690S/805S, V_{CC} falling	
	2.85	2.935	3.02		SP690S/805S, V_{CC} rising	
	2.55	2.625	2.70		SP690R/805R, V_{CC} falling	
	2.55	2.635	2.72		SP690R/805R, V_{CC} rising	
		3.00	3.075	3.12	V	SP802T/804T, V_{CC} falling
		3.00	3.085	3.14		SP802T/804T, V_{CC} rising
		2.88	2.925	3.00		SP802S/804S, V_{CC} falling
		2.88	2.935	3.02		SP802S/804S, V_{CC} rising
		2.59	2.625	2.70		SP802R/804R, V_{CC} falling
		2.59	2.635	2.72		SP802R/804R, V_{CC} rising
Reset Timeout Period, t_{WP}	140	200	280	ms		
\overline{RESET} , \overline{PFO} Output Voltage, V_{OH}	$V_{CC} - 0.3$	$V_{CC} - 0.15$		V	$I_{SOURCE} = 30\mu A$	
\overline{RESET} , \overline{PFO} Output Voltage, V_{OL}		0.06	0.30	V	$I_{SINK} = 1.2mA$, SP690_/802_ where $V_{CC} = V_{RST}$ minimum	
\overline{RESET} , \overline{PFO} Output Voltage, V_{OL}		0.13	0.30	V	$V_{BATTERY} = 0V$, $V_{CC} = 1.0V$, $I_{SINK} = 40\mu A$	
RESET Output Voltage, V_{OL}		0.06	0.30	V	$I_{SINK} = 1.2mA$, SP804_/805_ where $V_{CC} = V_{RST}$ maximum	
RESET Output Leakage Current, NOTE 11	-1		-1	μA	$V_{BATTERY} = 0V$, $V_{CC} = V_{RST}$ minimum, $V_{RESET} = 0V$ or V_{CC}	
Output Short to GND Current, I_{OS} , PFO and RESET		180	500	μA	$V_{CC} = 3.3V$, $V_{OH} = 0V$	
Watchdog Timeout, t_{WD}	1.12	1.60	2.24	s	$V_{CC} < 3.6V$	
WDI Pulse Width	1			μs		
WDI Input Threshold V_{IH} V_{IL}	$0.3 \times V_{CC}$		$0.7 \times V_{CC}$	V		
WDI Input Current	-1	0.01	1	μA	$0V < V_{CC} < 5.5V$	
PFI Input Threshold	1.200 1.225	1.25 1.25	1.300 1.275	V	SP690_/805_, $V_{CC} \leq 3.6V$, V_{PFI} falling SP802_/804_, $V_{CC} \leq 3.6V$, V_{PFI} falling	
PFI Input Current	-25	0.01	25	nA		
PFI Hysteresis, V_{PFH}		10	20	mV	PFI rising, $V_{CC} \leq 3.6V$	

SPECIFICATIONS (continued)

$V_{CC} = 3.17V$ to $5.50V$ for the SP690T/SP80_T, $V_{CC} = 3.02V$ to $5.50V$ for the SP690S/SP80_S, $V_{CC} = 2.72V$ to $5.50V$ for the SP690R/SP80_R, $V_{BATT} = 3.60V$, and $T_A = T_{MIN}$ to T_{MAX} unless otherwise noted. Typical values taken at $T_{AMB} = +25^{\circ}C$.

NOTE 1: The following are tested at $V_{BATT} = 3.6V$ and $V_{CC} = 5.5V$: V_{CC} supply current, watchdog functionality, logic input leakage, PFI functionality, and the \overline{RESET} and RESET states. The state of \overline{RESET} or RESET and PFO is tested at $V_{CC} = V_{CC}(\min)$.

NOTE 2: Tested $V_{BATT} = 3.6V$, $V_{CC} = 3.5V$ and $0V$.

NOTE 3: Leakage current into the battery is tested under the following worst-case conditions: $V_{CC} = 5.5V$, $V_{BATT} = 1.8V$ and at $V_{CC} = 1.5V$, $V_{BATT} = 1.0V$.

NOTE 4: "-" equals the battery-charging current, "+" equals the battery-discharging current.

NOTE 5: When $V_{SW} > V_{CC} > V_{BATT}$, V_{OUT} remains connected to V_{CC} until V_{CC} drops below V_{BATT} . The V_{CC} -to- V_{BATT} comparator has a small 25mV typical hysteresis to prevent oscillation.

NOTE 6: When $V_{BATT} > V_{CC} > V_{SW}$, V_{OUT} remains connected to V_{CC} until V_{CC} drops below the battery switch threshold, V_{SW} .

NOTE 7: V_{OUT} switches from V_{BATT} to V_{CC} when V_{CC} rises above the reset threshold, independent of V_{BATT} . Switchover back to V_{CC} occurs at the exact voltage that causes \overline{RESET} to go HIGH (on the SP804_ and SP805_ RESET goes LOW). Switchover occurs 200ms prior to reset.

NOTE 8: The reset threshold tolerance is wider for V_{CC} rising than for V_{CC} falling to accommodate the 10mV typical hysteresis, which prevents internal oscillation.

NOTE 9: SP690_ and SP802_ devices only.

NOTE 10: SP804_ and SP805_ devices only.

NOTE 11: The leakage current into or out of the RESET pin is tested with RESET asserted (RESET output high impedance).

INTERNAL BLOCK DIAGRAM

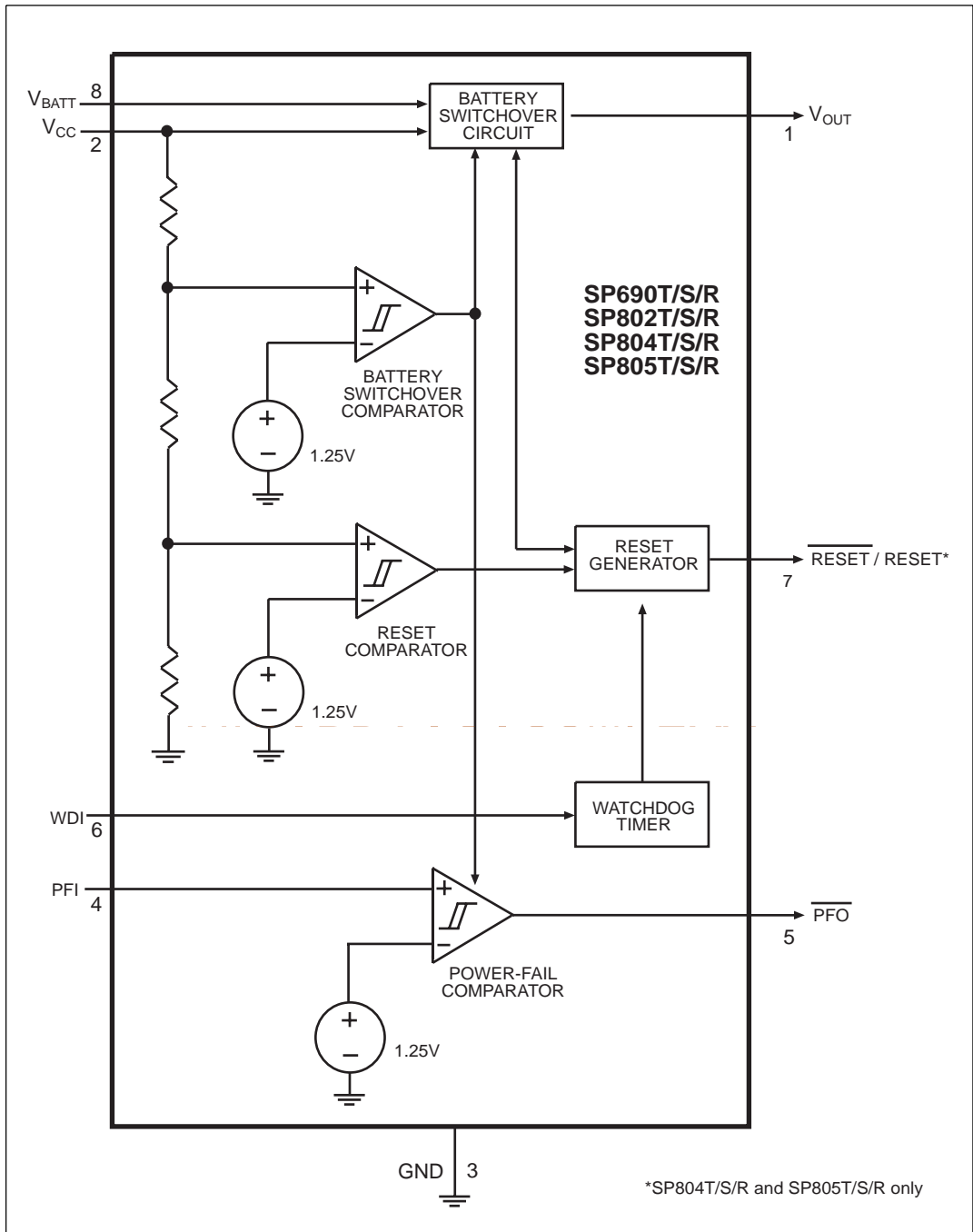

PINOUT

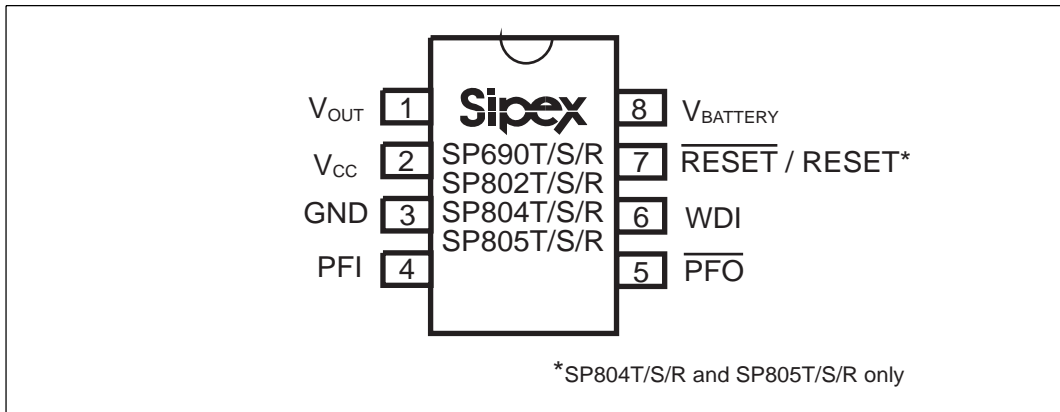

PIN ASSIGNMENTS

- Pin 1 — V_{OUT} — Output Supply Voltage for CMOS RAM. When V_{CC} is above the reset threshold, V_{OUT} connects to V_{CC} through a P-channel MOSFET switch. When V_{CC} falls below the V_{SW} and $V_{BATTERY}$, $V_{BATTERY}$ connects to V_{OUT} . Connect to V_{CC} if no battery is used.
- Pin 2 — V_{CC} — +5V Supply Input
- Pin 3 — GND — Ground reference for all signals
- Pin 4 — PFI — Power-Fail Comparator Input. When PFI is less than 1.25V or when V_{CC} falls below the V_{SW} , PFO goes LOW, otherwise PFO remains HIGH. Connect to GND if unused.
- Pin 5 — \overline{PFO} — Power-Fail Comparator Output. Leave open if unused.
- Pin 6 — WDI — Watchdog Input. If WDI remains HIGH or LOW for 1.6 seconds, the internal watchdog timer triggers a reset. The internal watchdog timer clears when reset is asserted or WDI sees a rising or falling edge. **The watchdog function cannot be disabled.**
- Pin 7 for **SP690_/802_ only** — Active-LOW Reset Output. — Whenever RESET is triggered by a watchdog timeout, it goes LOW for 200ms. It stays LOW whenever V_{CC} is below the reset threshold and remains LOW for 200ms after V_{CC} rises above the reset threshold or when the watchdog triggers a reset.
- Pin 7 for **SP804_/805_ only** — Active-HIGH Open-Drain Reset Output. — The inverse operation of RESET.
- Pin 8 — $V_{BATTERY}$ — Backup-Battery Input. When V_{CC} falls below V_{SW} and $V_{BATTERY}$, V_{OUT} switches from V_{CC} to $V_{BATTERY}$. When V_{CC} rises above the reset threshold, V_{OUT} reconnects to V_{CC} . $V_{BATTERY}$ may exceed V_{CC} . Connect to V_{CC} if no battery is used.

TYPICAL CHARACTERISTICS ($T_{AMB} = 25^{\circ}\text{C}$, unless otherwise noted)

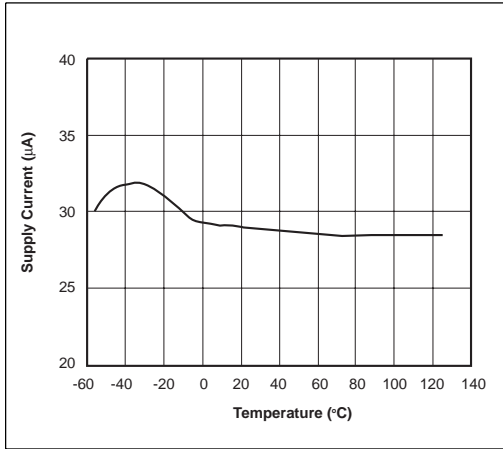

Figure 1. V_{CC} Supply Current vs. Temperature (Normal Mode)

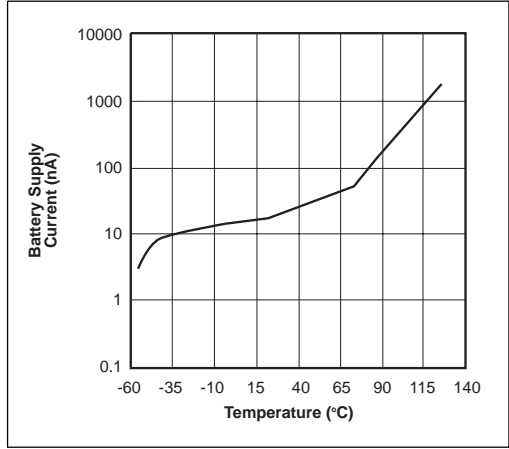

Figure 2. Battery Supply Current vs. Temperature

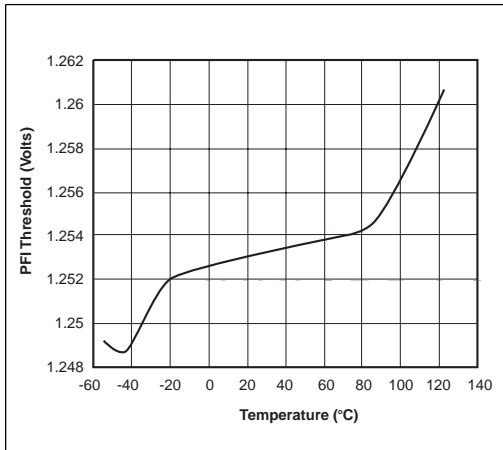

Figure 3. PFI Threshold vs. Temperature

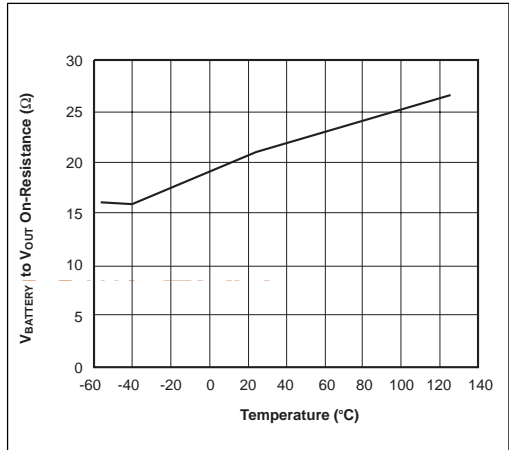

Figure 4. $V_{BATTERY}$ to V_{OUT} ON-Resistance vs. Temperature

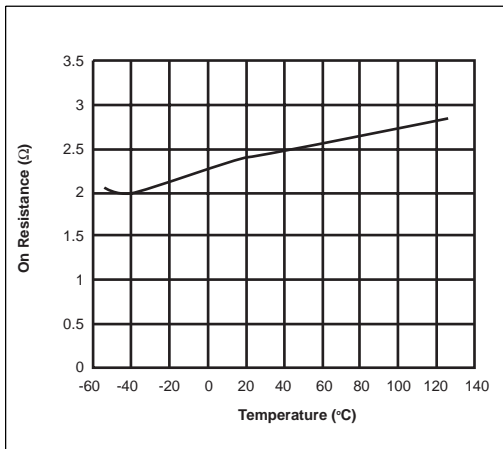

Figure 5. V_{CC} to V_{OUT} On-Resistance vs. Temperature

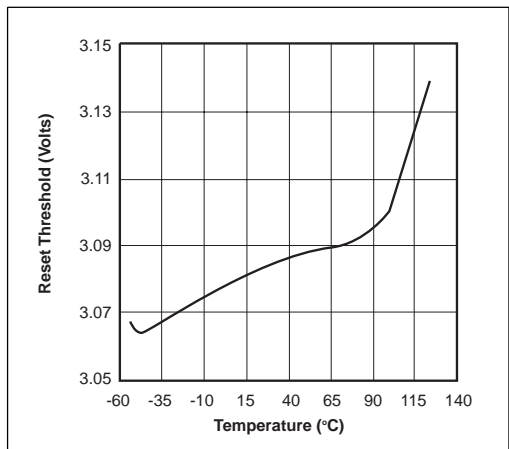

Figure 6. Reset Threshold vs. Temperature

www.BDTIC.com/Exar/

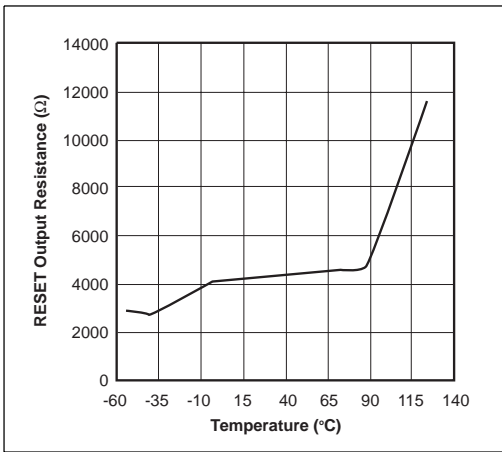

Figure 7. Reset Output Resistance vs. Temperature

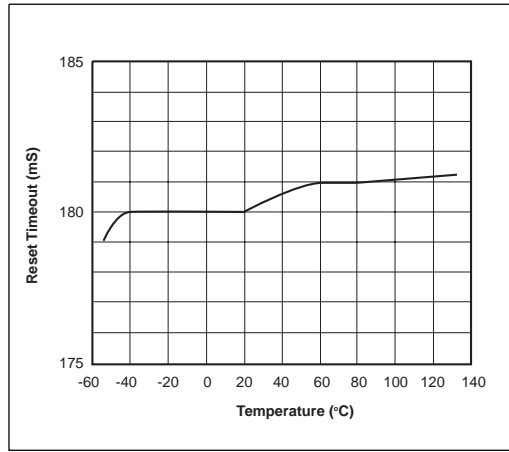

Figure 8. Reset Timeout vs. Temperature

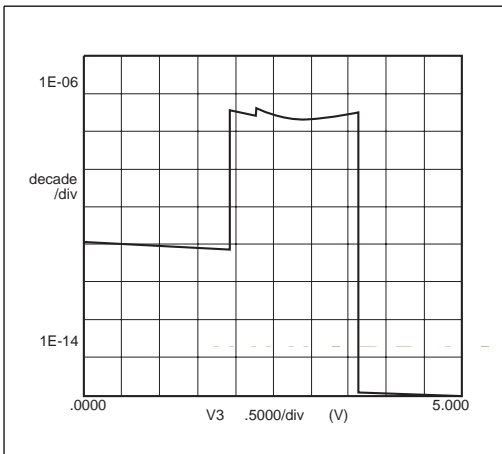

Figure 9. Battery Current vs. V_{CC} Voltage

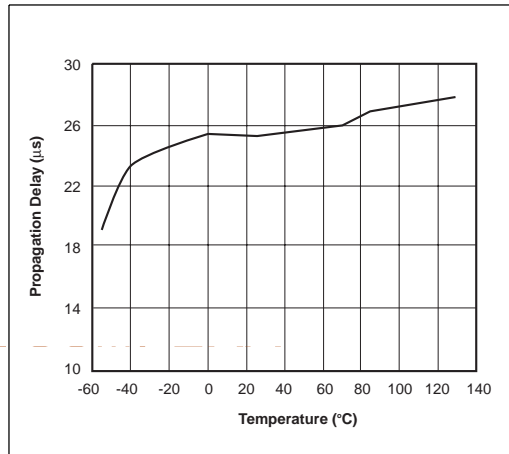

Figure 10. Reset-Comparator Propagation Delay vs. Temperature

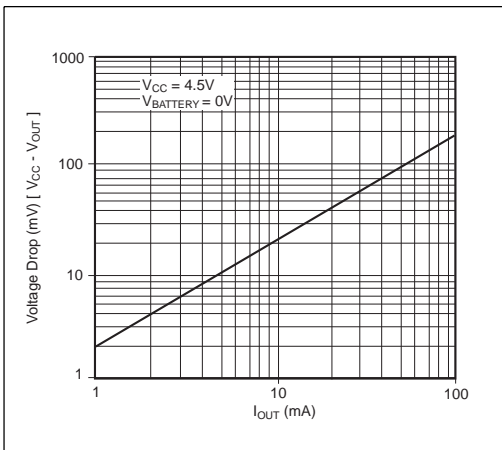

Figure 11. V_{CC} to V_{OUT} Vs. Output Current

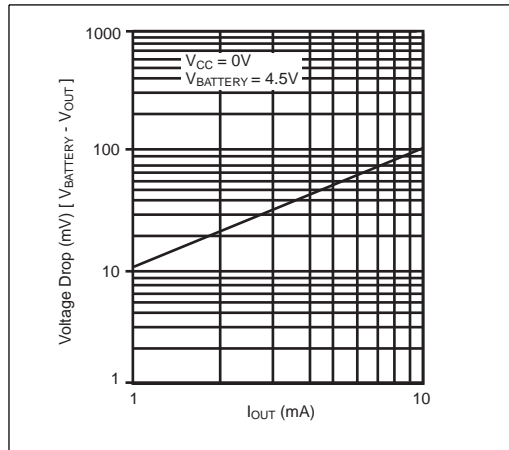

Figure 12. $V_{BATTERY}$ to V_{OUT} Vs. Output Current

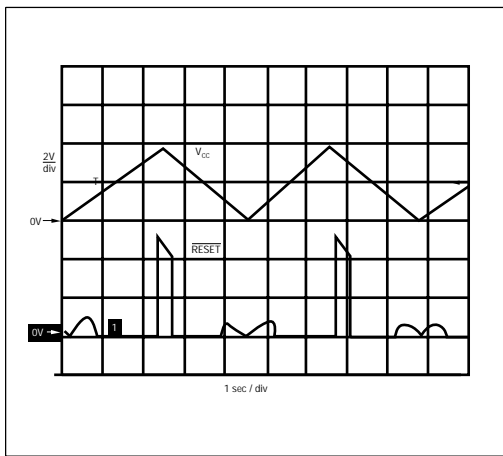

Figure 13A. SP690A RESET Output Voltage vs. Supply Voltage

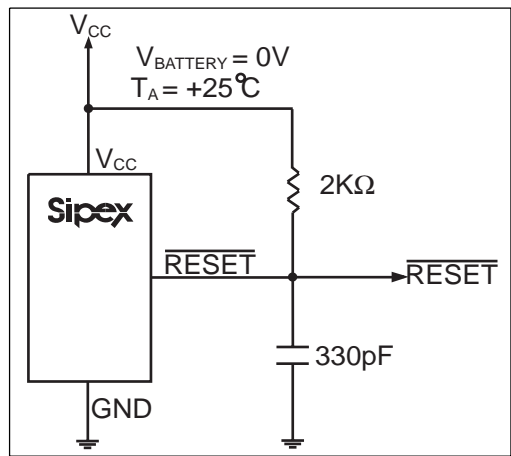

Figure 13B. Circuit for the SP690A/802L RESET Output Voltage vs. Supply Voltage

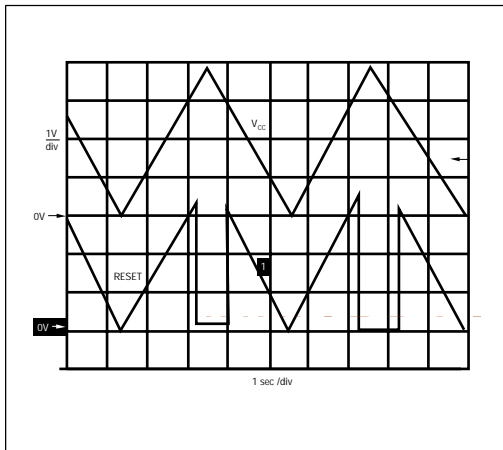

Figure 14A. SP805L RESET Output Voltage vs. Supply Voltage

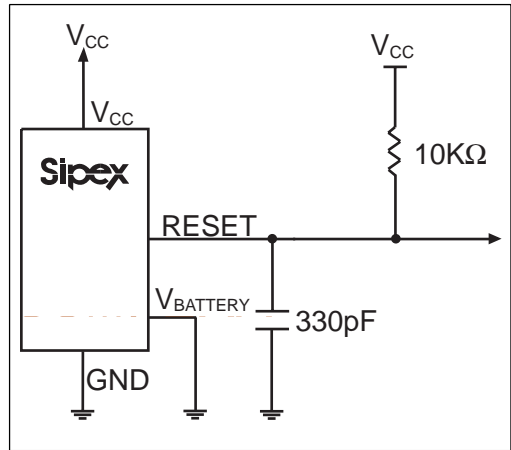

Figure 14B. Circuit for the SP805 RESET Output Voltage vs. Supply Voltage

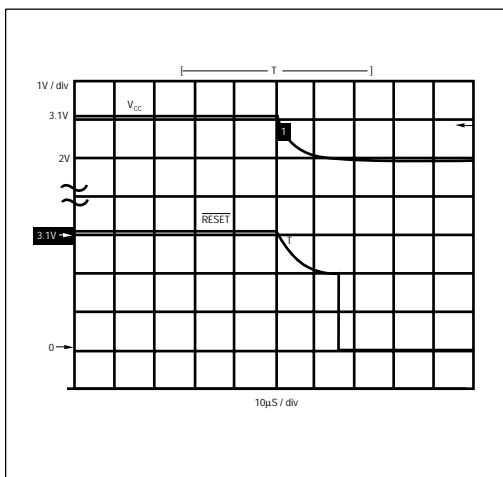

Figure 15A. SP690A RESET Response Time

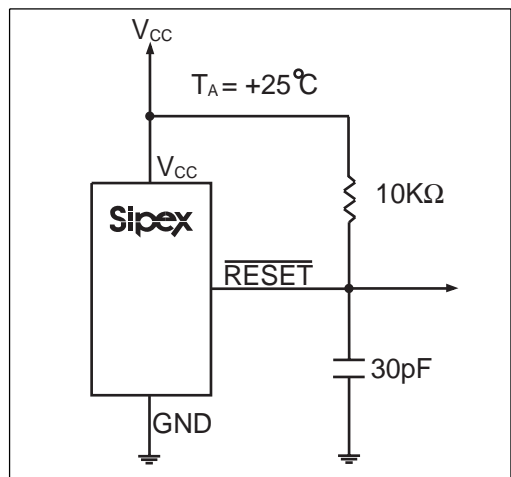

Figure 15B. Circuit for the SP690A/802L RESET Response Time

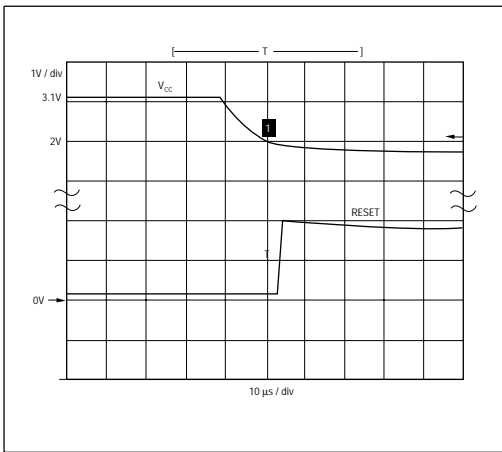

Figure 16A. SP805L RESET Response Time

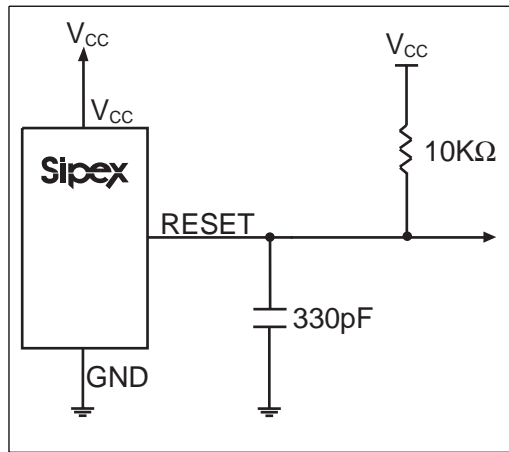

Figure 16B. Circuit for the SP805 RESET Response Time

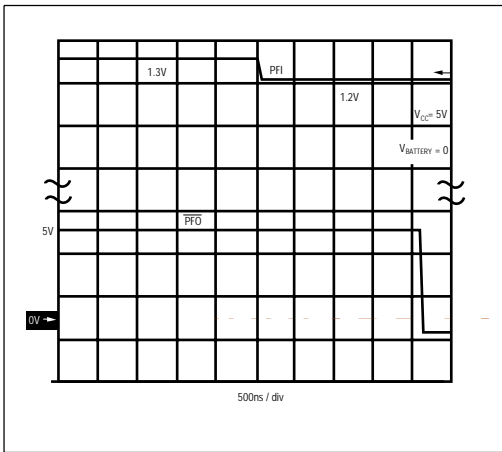

Figure 17A. Power-Fail Comparator Response Time (fall)

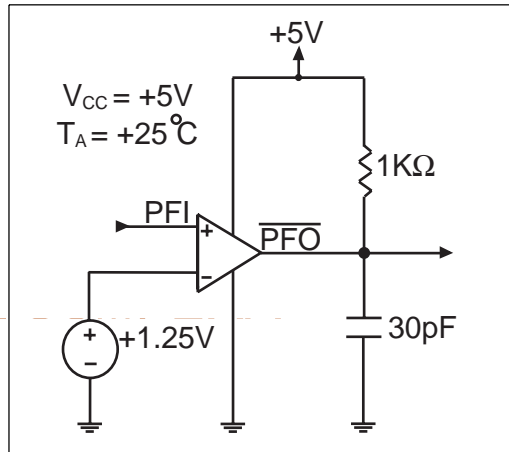

Figure 17B. Circuit for the Power-Fail Comparator Response Time (fall)

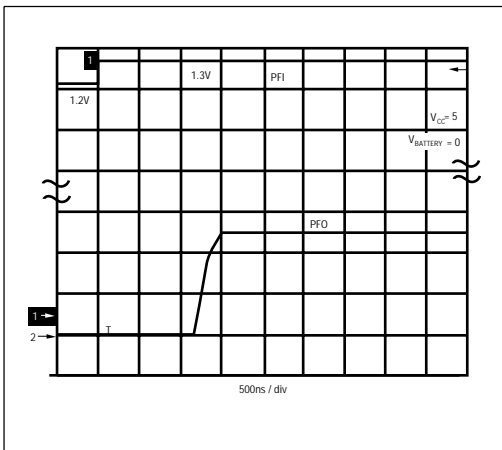

Figure 18A. Power-Fail Comparator Response Time (rise)

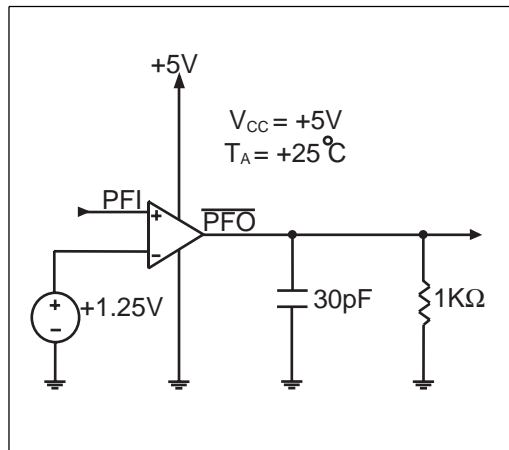

Figure 18B. Circuit for the Power-Fail Comparator Response Time (rise)

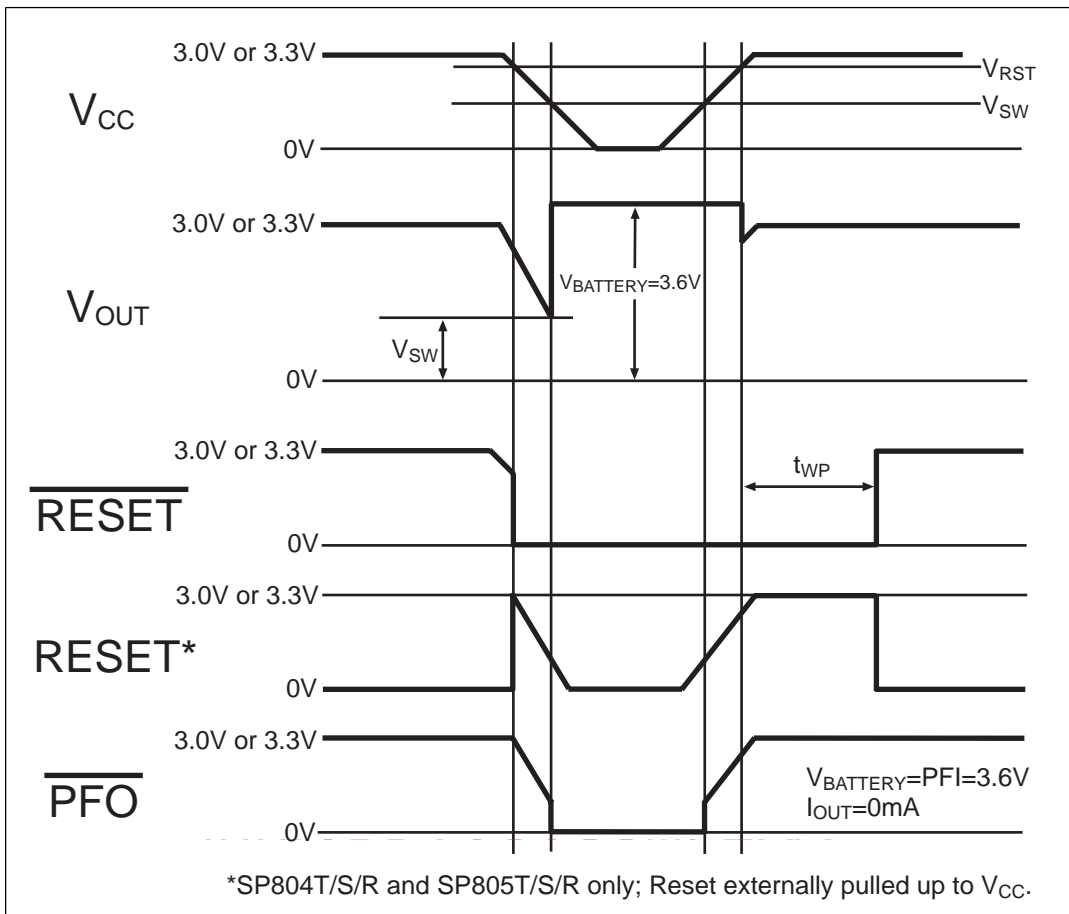

Figure 19. Timing Diagram

FEATURES

The **SP690T/S/R**, **SP802T/S/R**, **SP804T/S/R** and **SP805T/S/R** devices provide four key functions:

1. A battery backup switch for CMOS RAM, CMOS microprocessors, or other logic.
2. A reset output during power-up, power-down and brownout conditions.
3. A reset pulse if the optional watchdog timer has not been toggled within a specified time.
4. A 1.25V threshold detector for power-fail warning, low battery detection, or to monitor a power supply other than 3.3V or 3.0V.

The **SP690T/S/R**, **SP802T/S/R**, **SP804T/S/R** and **SP805T/S/R** devices differ in their reset-voltage threshold levels and are ideally suited for applications in automotive systems, intelligent instruments, and battery-powered computers and controllers. The series is a solid match for designs where it is critical to monitor the power supply to the μP and it's related digital components.

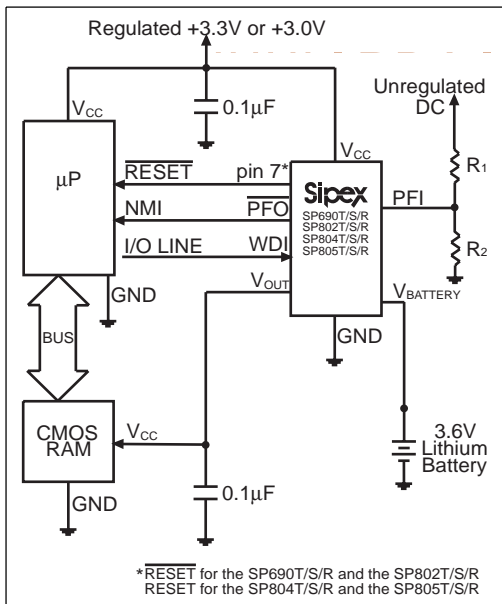

Figure 20. Typical Operating Circuit

THEORY OF OPERATION

The **SP690T/S/R**, **SP802T/S/R**, **SP804T/S/R** and **SP805T/S/R** devices are microprocessor (μP) supervisory circuits that monitor the power supplied to digital circuits such as microprocessors, microcontrollers, or memory. The series is an ideal solution for portable, battery-powered equipment that requires power supply monitoring. Implementing this series will reduce the number of components and overall complexity. The watchdog functions of this product family will continuously oversee the operational status of a system.

These μP supervisory circuits are not short-circuit protected. Shorting V_{OUT} to ground - excluding power-up transients such as charging a decoupling capacitor - may potentially damage these devices. Decouple both V_{CC} and V_{BATTERY} pins to ground by placing $0.1\mu\text{F}$ capacitors as close to the device as possible. The operational features and benefits of the **SP690T/S/R**, **SP802T/S/R**, **SP804T/S/R** and **SP805T/S/R** devices are described in more detail below.

Reset Output

The microprocessor's (μP 's) reset input starts the μP in a known state. When the μP is in an unknown state, it should be held in reset. The **SP690T/S/R**, **SP802T/S/R**, **SP804T/S/R** and **SP805T/S/R** devices assert reset during power-up and prevent code execution errors during power-down or brownout conditions.

$\overline{\text{RESET}}$ is guaranteed to be a logic LOW for $0\text{V} < V_{\text{CC}} < V_{\text{RST}}$, provided that V_{BATTERY} is greater than 1V. Without a backup battery, $\overline{\text{RESET}}$ is guaranteed valid for $V_{\text{CC}} > 1\text{V}$. Once V_{CC} exceeds the reset threshold, an internal timer keeps $\overline{\text{RESET}}$ low for the reset timeout period. After this period, $\overline{\text{RESET}}$ goes HIGH, as seen in Figure 19.

If a brownout condition occurs and V_{CC} dips below the reset threshold, $\overline{\text{RESET}}$ goes LOW. Each time $\overline{\text{RESET}}$ is triggered, it stays low for the reset timeout period. Any time V_{CC} goes below the reset threshold, the internal timer restarts.

The watchdog timer can also initiate a reset. Refer to the **Watchdog Input** section.

The **SP804T/S/R** and **SP805T/S/R** active-HIGH RESET output is open drain and the inverse of the **SP690T/S/R** and **SP802T/S/R** $\overline{\text{RESET}}$ outputs.

$\overline{\text{RESET}}$ is also triggered by a watchdog timeout. If WDI remains either high or low for a period that exceeds the watchdog timeout period (1.6 sec), $\overline{\text{RESET}}$ pulses low for 200mS. As long as $\overline{\text{RESET}}$ is asserted, the watchdog timer remains cleared. When $\overline{\text{RESET}}$ comes high, the watchdog resumes timing and must be serviced within 1.6sec. If WDI is tied high or low, a RESET pulse is triggered every 1.8sec (t_{WD} plus t_{RS}).

Reset Threshold

The **SP690T** and **SP805T** devices are designed for 3.3V systems with a $\pm 5\%$ power-supply tolerance and a 10% system tolerance. Except for watchdog faults, reset will not assert as long as the power supply remains above 3.15V (3.3V - 5%). Reset is guaranteed to assert before the power supply falls below 3.0V.

The **SP690S** and **SP805S** devices are designed for 3.3V $\pm 10\%$ power supplies. Except for watchdog faults, they are guaranteed not to assert reset as long as the supply remains above 3.0V (3.3V - 10%). Reset is guaranteed to assert before the power supply fails below 2.85V (V_{CC} - 14%).

The **SP690R** and **SP805R** devices are optimized for monitoring 3.0V $\pm 10\%$ power supplies. Reset will not occur until V_{CC} falls below 2.7V (3.0V - 10%), but is guaranteed to occur before the supply falls below 2.55V (3.0V - 15%).

The **SP802T/S/R** and **SP804T/S/R** devices are respectively similar to the **SP690T/S/R** and **SP805T/S/R** devices with tightened reset and power-fail threshold tolerances.

Watchdog Input

The watchdog circuit monitors the μP 's activity. If the μP does not toggle the watchdog input (WDI) within 1.6sec, a reset pulse is triggered. The internal 1.6sec timer is cleared by either a reset pulse or by a transition (LOW-to-HIGH or HIGH-to-LOW) at WDI. If WDI is tied HIGH or LOW, a $\overline{\text{RESET}}$ pulse is triggered every 1.8sec (t_{WD} plus t_{RS}).

As long as reset is asserted, the timer remains cleared and does not count. As soon as reset is de-asserted, the timer starts counting. Unlike the 5V **SP690A** series, the watchdog function **cannot** be disabled.

Power-Fail Comparator

The power-fail comparator can be used as an under-voltage detector to signal the failing of a power supply (it is completely separate from the rest of the circuitry and does not need to be dedicated to this function). The PFI input is compared to an internal 1.25V. If PFI is less than V_{PFT} , PFO goes low.

The power-fail comparator turns off and $\overline{\text{PFO}}$ goes LOW when V_{CC} falls below V_{SW} on power-down. The power-fail comparator turns on as V_{CC} crosses V_{SW} on power-up. If the comparator is not used, connect PFI to ground and leave $\overline{\text{PFO}}$ unconnected.

Backup-Battery Switchover

In the event of a brownout or power failure, it may be necessary to preserve the contents of RAM. With a backup battery installed at V_{BATTERY} , the devices automatically switch RAM to backup power when V_{CC} fails.

This family of μP supervisors (designed for 3.3V and 3V systems) doesn't always connect V_{BATTERY} to V_{OUT} when V_{BATTERY} is greater than V_{CC} . V_{BATTERY} connects to V_{OUT} (through a 15 Ω switch) when V_{CC} is below V_{SW} and V_{BATTERY} is greater than V_{CC} .

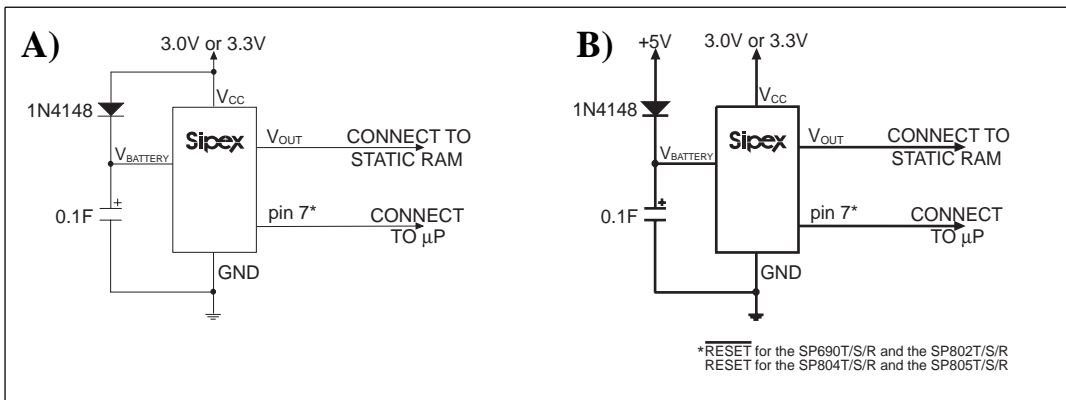

Figure 21. Using a High Capacity Capacitor as a Backup Power Source

Switchover at V_{SW} (2.40V) ensures that battery-backup mode is entered before V_{OUT} gets too close to the 2.0V minimum required to reliably retain data in CMOS RAM. Switchover at higher V_{CC} voltages would decrease backup-battery life. When V_{CC} recovers, switchover is deferred until V_{CC} rises above the reset threshold, V_{RST} , to ensure a stable supply. V_{OUT} is connected to V_{CC} through a 1.5Ω PMOS power switch.

Using a High Capacity Capacitor as a Backup Power Source

Figure 21 shows two ways to use a High Value Capacitor as a backup power source. The High Value Capacitor may be connected through a diode to the 3V input as in Figure 21A or, if a 5V supply is also available, the High Value Capacitor may be charged up to the 5V supply as in Figure 21B allowing a longer backup period. Since $V_{BATTERY}$ can exceed V_{CC} while V_{CC} is above the reset threshold, there are no special precautions when using these μP supervisors with a High Value Capacitor.

Operation Without a Backup Power Source

These μP supervisors were designed for battery-backed applications. If a backup power source is not used, connect both $V_{BATTERY}$ and V_{OUT} to V_{CC} . Since there is no need to switch over to any backup power source, V_{OUT} does not need to be switched. A direct connection to V_{CC} eliminates any voltage drops across the switch which may push V_{OUT} below V_{CC} .

Replacing the Backup Battery

If $V_{BATTERY}$ is decoupled with a 0.1 μF capacitor to ground, the backup battery can be removed while V_{CC} remains valid without danger of triggering RESET/RESET. As long as V_{CC} stays above V_{SW} , battery-backup mode cannot be entered.

Adding Hysteresis to the Power-Fail Comparator

The power-fail comparator has a typical input hysteresis of 10mV. This is sufficient for most applications where a power-supply line is being monitored through an external voltage divider (refer to the Monitoring an Additional Power Supply section).

If additional noise margin is desired, connect a resistor between PFO and PFI as shown in Figure 22A. Select the ratio of R1 and R2 such that PFI sees 1.25V when V_{IN} falls to its trip point (V_{TRIP}). R3 adds the hysteresis and will typically be more than 10 times the value of R1 or R2. The hysteresis window extends both above (V_H) and below (V_L) the original trip point (V_{TRIP}).

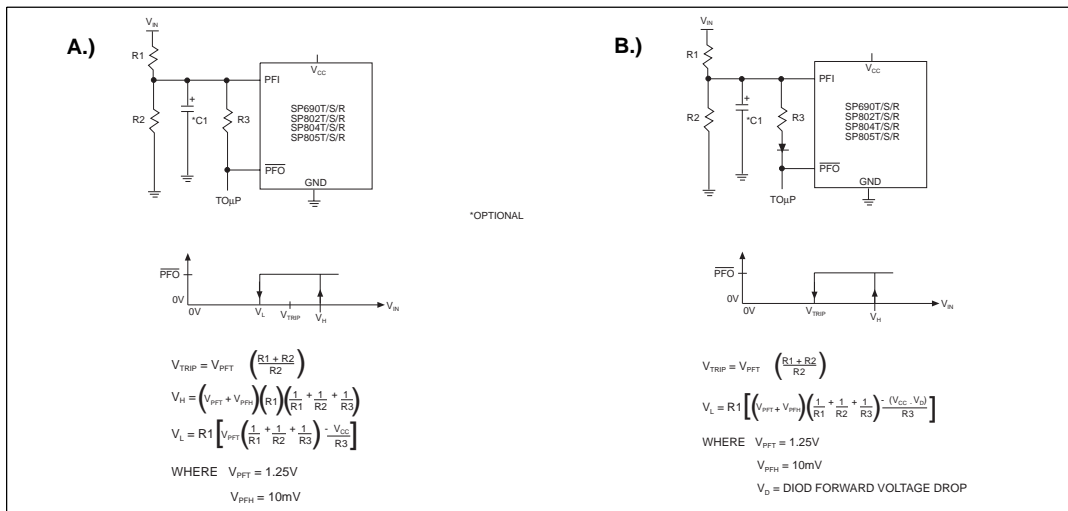

Figure 22A. Adding Additional Hysteresis to the Power-Fail Comparator.

Figure 22B. Shifting the Additional Hysteresis above V_{PFT}

Connecting an ordinary signal diode in series with R3, as in **Figure 22B**, causes the lower trip point (V_L) to coincide with the trip point without hysteresis (V_{TRIP}), so the entire hysteresis window occurs above V_{TRIP} . This method provides additional noise margin without compromising the accuracy of the power-fail threshold when the monitored voltage is falling. It is useful for accurately detecting when a voltage falls past a threshold.

The current through R1 and R2 should be at least $1\mu A$ to ensure that the 25nA (max over extended temperature range) PFI input current does not shift the trip point. R3 should be larger than $10k\Omega$ so it does not load down the PFO pin. Capacitor C1 adds additional noise rejection.

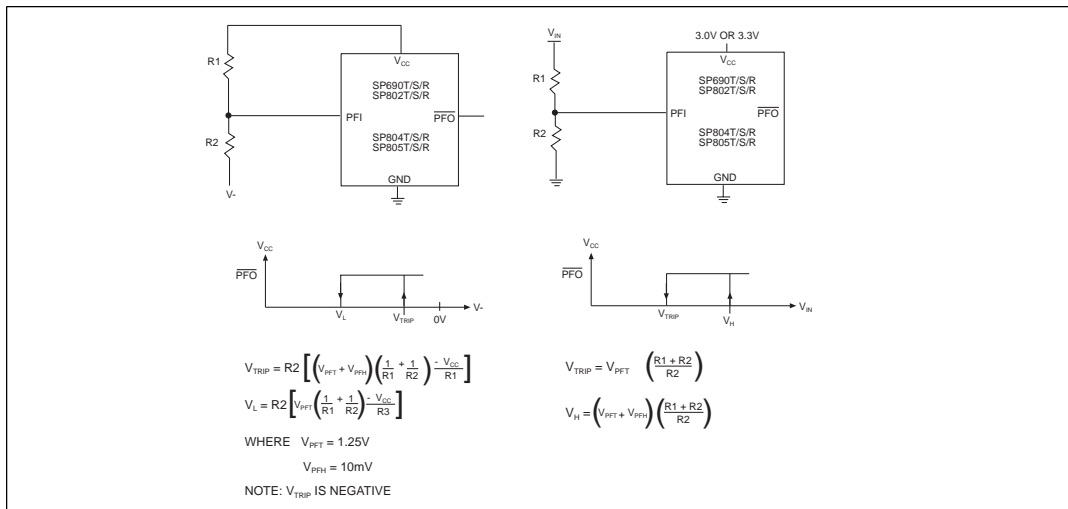

Figure 23. Using the Power-Fail Comparator to Monitor an Additional Power Supply

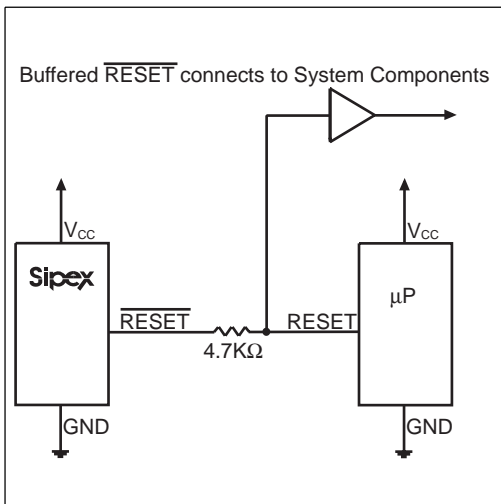

Figure 24. Interfacing to Microprocessors with Bidirectional RESET I/O

Monitoring an Additional Power Supply

These μP supervisors can monitor either positive or negative supplies using a resistor voltage divider to PFI. PFO can be used to generate an interrupt to the μP, as seen in Figure 23.

Interfacing to μPs with Bidirectional Reset Pins

Any μPs with bidirectional reset pins, such as the Motorola 68HC11 series, can interface with the SP690 and the SP802 RESET outputs. For example, if the RESET output is driven HIGH and the μP wants to pull it LOW, indeterminate logic levels may result. To correct this, connect a 4.7kΩ resistor between the RESET output and the μP reset I/O, as in Figure 24. Buffer the RESET output to other system components.

Negative-Going V_{CC} Transients

While issuing resets to the μP during power-up, power-down, and brownout conditions, these supervisors are relatively immune to short-duration negative-going V_{CC} transients (glitches). It is usually undesirable to reset the μP when V_{CC} experiences only small glitches.

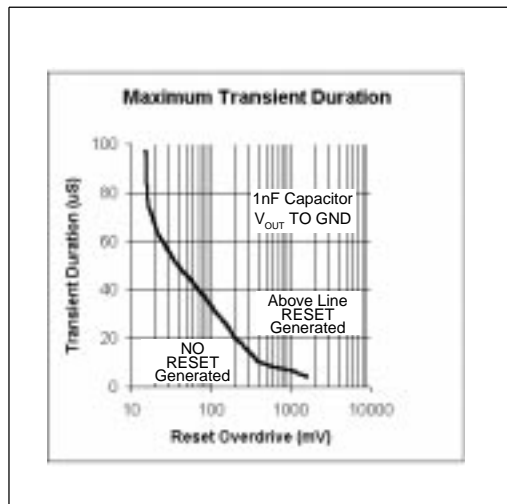
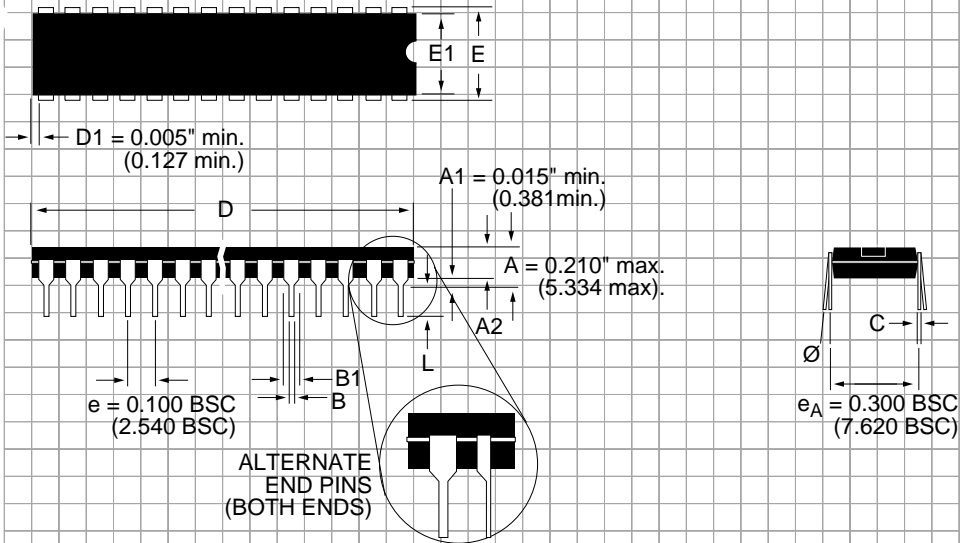

Figure 25. Maximum Transient Duration without Causing a Reset Pulse vs. Reset Comparator Overdrive

Figure 25 shows maximum transient duration vs. reset-comparator overdrive, for which reset pulses are not generated. The data was generated using negative-going V_{CC} pulses, starting at 3.3V and ending below the reset threshold by the magnitude indicated (reset comparator overdrive). The graph shows the maximum pulse width with a negative-going V_{CC} transient may typically have without causing a reset pulse to be issued. As the amplitude of the transient increases (i.e. goes farther below the reset threshold), the maximum allowable pulse width decreases. Typically, a V_{CC} transient that goes 100mV below the reset threshold and lasts for 40μs or less will not cause a reset pulse to be issued. A 100nF bypass capacitor mounted close to the V_{CC} pin provides additional transient immunity.

PACKAGE: PLASTIC DUAL-IN-LINE (NARROW)



DIMENSIONS (Inches) Minimum/Maximum (mm)	8-PIN	14-PIN	16-PIN	18-PIN	20-PIN	22-PIN
A2	0.115/0.195 (2.921/4.953)	0.115/0.195 (2.921/4.953)	0.115/0.195 (2.921/4.953)	0.115/0.195 (2.921/4.953)	0.115/0.195 (2.921/4.953)	0.115/0.195 (2.921/4.953)
B	0.014/0.022 (0.356/0.559)	0.014/0.022 (0.356/0.559)	0.014/0.022 (0.356/0.559)	0.014/0.022 (0.356/0.559)	0.014/0.022 (0.356/0.559)	0.014/0.022 (0.356/0.559)
B1	0.045/0.070 (1.143/1.778)	0.045/0.070 (1.143/1.778)	0.045/0.070 (1.143/1.778)	0.045/0.070 (1.143/1.778)	0.045/0.070 (1.143/1.778)	0.045/0.070 (1.143/1.778)
C	0.008/0.014 (0.203/0.356)	0.008/0.014 (0.203/0.356)	0.008/0.014 (0.203/0.356)	0.008/0.014 (0.203/0.356)	0.008/0.014 (0.203/0.356)	0.008/0.014 (0.203/0.356)
D	0.355/0.400 (9.017/10.160)	0.735/0.775 (18.669/19.685)	0.780/0.800 (19.812/20.320)	0.880/0.920 (22.352/23.368)	0.980/1.060 (24.892/26.924)	1.145/1.155 (29.083/29.337)
E	0.300/0.325 (7.620/8.255)	0.300/0.325 (7.620/8.255)	0.300/0.325 (7.620/8.255)	0.300/0.325 (7.620/8.255)	0.300/0.325 (7.620/8.255)	0.300/0.325 (7.620/8.255)
E1	0.240/0.280 (6.096/7.112)	0.240/0.280 (6.096/7.112)	0.240/0.280 (6.096/7.112)	0.240/0.280 (6.096/7.112)	0.240/0.280 (6.096/7.112)	0.240/0.280 (6.096/7.112)
L	0.115/0.150 (2.921/3.810)	0.115/0.150 (2.921/3.810)	0.115/0.150 (2.921/3.810)	0.115/0.150 (2.921/3.810)	0.115/0.150 (2.921/3.810)	0.115/0.150 (2.921/3.810)
∅	0°/15° (0°/15°)	0°/15° (0°/15°)	0°/15° (0°/15°)	0°/15° (0°/15°)	0°/15° (0°/15°)	0°/15° (0°/15°)

**PACKAGE: PLASTIC
SMALL OUTLINE (SOIC)
(NARROW)**

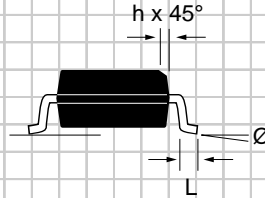
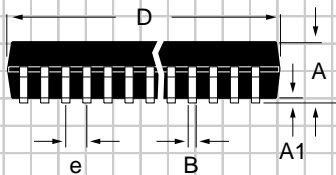
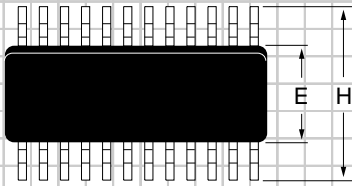

DIMENSIONS (Inches) Minimum/Maximum (mm)	8-PIN	14-PIN	16-PIN
A	0.053/0.069 (1.346/1.748)	0.053/0.069 (1.346/1.748)	0.053/0.069 (1.346/1.748)
A1	0.004/0.010 (0.102/0.249)	0.004/0.010 (0.102/0.249)	0.004/0.010 (0.102/0.249)
B	0.014/0.019 (0.35/0.49)	0.013/0.020 (0.330/0.508)	0.013/0.020 (0.330/0.508)
D	0.189/0.197 (4.80/5.00)	0.337/0.344 (8.552/8.748)	0.386/0.394 (9.802/10.000)
E	0.150/0.157 (3.802/3.988)	0.150/0.157 (3.802/3.988)	0.150/0.157 (3.802/3.988)
e	0.050 BSC (1.270 BSC)	0.050 BSC (1.270 BSC)	0.050 BSC (1.270 BSC)
H	0.228/0.244 (5.801/6.198)	0.228/0.244 (5.801/6.198)	0.228/0.244 (5.801/6.198)
h	0.010/0.020 (0.254/0.498)	0.010/0.020 (0.254/0.498)	0.010/0.020 (0.254/0.498)
L	0.016/0.050 (0.406/1.270)	0.016/0.050 (0.406/1.270)	0.016/0.050 (0.406/1.270)
Ø	0°/8° (0°/8°)	0°/8° (0°/8°)	0°/8° (0°/8°)

ORDERING INFORMATION

Model	Temperature Range	Package Types
SP690TCN.....	0°C to +70°C.....	8-Pin NSOIC
SP690TCP.....	0°C to +70°C.....	8-Pin PDIP
SP690TEN.....	-40°C to +85°C.....	8-Pin NSOIC
SP690TEP.....	-40°C to +85°C.....	8-Pin PDIP
SP690SCN.....	0°C to +70°C.....	8-Pin NSOIC
SP690SCP.....	0°C to +70°C.....	8-Pin PDIP
SP690SEN.....	-40°C to +85°C.....	8-Pin NSOIC
SP690SEP.....	-40°C to +85°C.....	8-Pin PDIP
SP690RCN.....	0°C to +70°C.....	8-Pin NSOIC
SP690RCP.....	0°C to +70°C.....	8-Pin PDIP
SP690REN.....	-40°C to +85°C.....	8-Pin NSOIC
SP690REP.....	-40°C to +85°C.....	8-Pin PDIP
SP802TCN.....	0°C to +70°C.....	8-Pin NSOIC
SP802TCP.....	0°C to +70°C.....	8-Pin PDIP
SP802TEN.....	-40°C to +85°C.....	8-Pin NSOIC
SP802TEP.....	-40°C to +85°C.....	8-Pin PDIP
SP802SCN.....	0°C to +70°C.....	8-Pin NSOIC
SP802SCP.....	0°C to +70°C.....	8-Pin PDIP
SP802SEN.....	-40°C to +85.....	8-Pin NSOIC
SP802SEP.....	-40°C to +85°C.....	8-Pin PDIP
SP802RCN.....	0°C to 0°C.....	8-Pin NSOIC
SP802RCP.....	0°C to +70°C.....	8-Pin PDIP
SP802REN.....	-40°C to +85°C.....	8-Pin NSOIC
SP802REP.....	-40°C to +85°C.....	8-Pin PDIP
SP804TCN.....	0°C to +70°C.....	8-Pin NSOIC
SP804TCP.....	0°C to +70°C.....	8-Pin PDIP
SP804TEN.....	-40°C to +85°C.....	8-Pin NSOIC
SP804TEP.....	-40°C to +85°C.....	8-Pin PDIP
SP804SCN.....	0°C to +70°C.....	8-Pin NSOIC
SP804SCP.....	0°C to +70°C.....	8-Pin PDIP
SP804SEN.....	-40°C to +85°C.....	8-Pin NSOIC
SP804SEP.....	-40°C to +85°C.....	8-Pin PDIP
SP804RCN.....	0°C to +70°C.....	8-Pin NSOIC
SP804RCP.....	0°C to +70°C.....	8-Pin PDIP
SP804REN.....	-40°C to +85°C.....	8-Pin NSOIC
SP804REP.....	-40°C to +85°C.....	8-Pin PDIP
SP805TCN.....	0°C to +70°C.....	8-Pin NSOIC
SP805TCP.....	0°C to +70°C.....	8-Pin PDIP
SP805TEN.....	-40°C to +8C.....	8-Pin NSOIC
SP805TEP.....	-40°C to +85°C.....	8-Pin PDIP
SP805SCN.....	0°C to +70°C.....	8-Pin NSOIC
SP805SCP.....	0°C to +70°C.....	8-Pin PDIP
SP805SEN.....	-40°C to +85°C.....	8-Pin NSOIC
SP805SEP.....	-40°C to +85°C.....	8-Pin PDIP
SP805RCN.....	0°C to +70°C.....	8-Pin NSOIC
SP805RCP.....	0°C to +70°C.....	8-Pin PDIP
SP805REN.....	-40°C to +85°C.....	8-Pin NSOIC
SP805REP.....	-40°C to +85°C.....	8-Pin PDIP

Please consult the factory for pricing and availability on a Tape-On-Reel option.

www.BDTIC.com/Exar/



SIGNAL PROCESSING EXCELLENCE

Sipex Corporation

**Headquarters and
Sales Office**

22 Linnell Circle
Billerica, MA 01821
TEL: (978) 667-8700
FAX: (978) 670-9001
e-mail: sales@sipex.com

Sales Office

233 South Hillview Drive
Milpitas, CA 95035
TEL: (408) 934-7500
FAX: (408) 935-7600

Sipex Corporation reserves the right to make changes to any products described herein. Sipex does not assume any liability arising out of the application or use of any product or circuit described herein; neither does it convey any license under its patent rights nor the rights of others.

www.BDTIC.com/Exar/