

1ppm/°C, 5.0V, Precision Low-Power FGA™ Voltage Reference

FEATURES

- Ultra-Low Temperature Coefficient: 1ppm/°C
- Absolute Initial Accuracy: ±0.5mV
- 10ppm Thermal Hysteresis
- Ultra-Low Supply Current : 800nA maximum
- Long Term Stability: 10ppm/1,000Hrs
- 10mA Source & Sink Current
- 80 mA Short Circuit Current Continuous
- ESD: 5kV (Human Body Model), 500V (Machine Model)
- Standard SOIC-8 Package
- Temp. Range: -40°C to +85°C
- Pb-Free Plus Anneal Available (RoHS Compliant)

DESCRIPTION

The X60008A-50 is an extremely stable low power, high accuracy voltage reference fabricated in Intersil's proprietary Floating Gate Analog technology.

The X60008A-50 features guaranteed 1 ppm/°C maximum temperature coefficient, absolute initial accuracy of ±500µV and extremely low, 10ppm thermal hysteresis.

Operating power consumption is typically 500nA and load regulation is guaranteed up to 10mA (source and sink). Short circuit current is guaranteed at 80mA continuous.

The excellent accuracy and stability performance of the X60008A-50 coupled with its low power consumption is an ideal choice for battery powered high resolution data acquisition systems.

APPLICATIONS

- | | | |
|------------------------------------|-----------------------|------------------------------|
| • High Resolution A/Ds & D/As | • Digital Meters | • Precision Oscillators |
| • High-Accuracy Reference Standard | • ATE Equipment | • Threshold Detectors |
| • Precision Regulators | • V-F Converters | • Process Control |
| • Precision Current Sources | • Strain Gage Bridges | • Battery Management Systems |
| • Smart sensors | • Calibration Systems | • Servo Systems |

TYPICAL APPLICATION

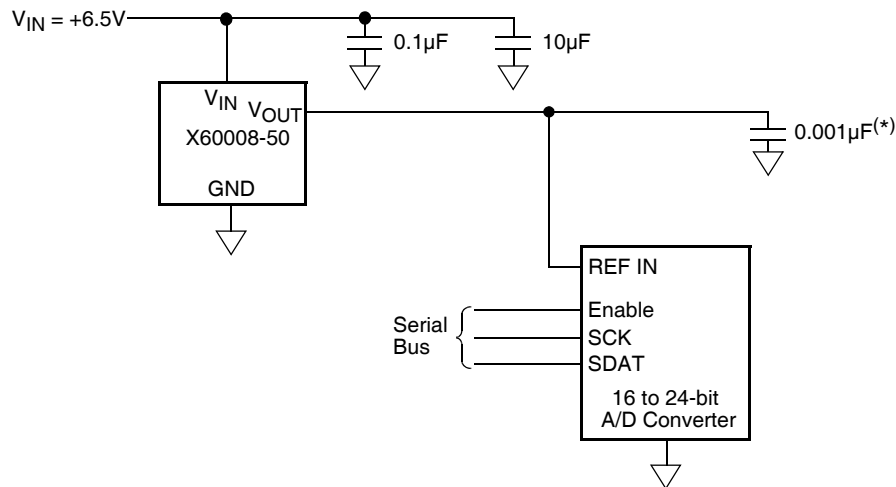

(*)Also see Figure 3 in Applications Information

X60008A-50

PACKAGE DIAGRAM

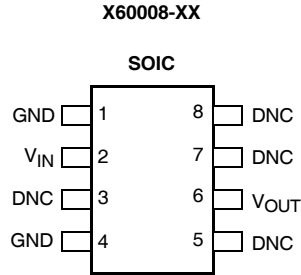

PIN CONFIGURATIONS

Pin Name	Description
GND	Ground Connection
V _{IN}	Power Supply Input Connection
V _{OUT}	Voltage Reference Output Connection
DNC	Do Not Connect; Internal Connection – Must Be Left Floating

Ordering Information

PART NUMBER	PART MARKING	V _{OUT} OPTION (V)	GRADE	TEMP. RANGE (°C)	PACKAGE	PKG. DWG. #
X60008AIS8-50	X60008A I	5.000	±0.5mV, 1ppm/°C	-40 to +85	8 Ld SOIC (150 mil)	MDP0027
X60008AIS8Z-50* (Note)	X60008A Z150			-40 to +85	8 Ld SOIC (150 mil) (Pb-free)	MDP0027

*Add "T1" suffix for tape and reel.

NOTE: Intersil Pb-free plus anneal products employ special Pb-free material sets; molding compounds/die attach materials and 100% matte tin plate termination finish, which are RoHS compliant and compatible with both SnPb and Pb-free soldering operations. Intersil Pb-free products are MSL classified at Pb-free peak reflow temperatures that meet or exceed the Pb-free requirements of IPC/JEDEC J STD-020.

ABSOLUTE MAXIMUM RATINGS

Storage Temperature Range..... -65°C to +125°C
 Voltage on any Pin Referred to
 Ground..... -0.5V to +10V
 Lead Temperature
 (soldering, 10s) +225°C

COMMENT

Absolute Maximum Ratings indicate limits beyond which permanent damage to the device and impaired reliability may occur. These are stress ratings provided for information only and functional operation of the device at these or any other conditions beyond those indicated in the operational sections of this specification are not implied.

For guaranteed specifications and test conditions, see Electrical Characteristics.

The guaranteed specifications apply only for the test conditions listed. Some performance characteristics may degrade when the device is not operated under the listed test conditions.

RECOMMENDED OPERATING CONDITIONS

Temperature	Min.	Max.
Industrial	-40°C	+85°C

ELECTRICAL CHARACTERISTICS (Operating Conditions: $V_{IN} = +6.5V$, $I_{OUT} = 0mA$, $T_A = -40$ to $+85^\circ C$ unless otherwise noted).

Symbol	Parameter	Conditions	Min	Typ	Max	Units
V_{OUT}	Output Voltage			5.000		V
V_{OA}	V_{OUT} Accuracy	$T_A = 25^\circ C$	-0.5		+0.5	mV
I_{IN}	Supply Current			500	800	nA
V_{IN}	Input Voltage Range		5.1		9.0	V
TC V_{OUT}	Output Voltage Temperature Coefficient	$-40^\circ C \leq T_A \leq +85^\circ C$ (note:1)		0.5	1.0	ppm/ $^\circ C$
$\Delta V_{OUT}/\Delta V_{IN}$	Line Regulation	$+5.0V \leq V_{IN} \leq +5.9V$			100	$\mu V/V$
$\Delta V_{OUT}/\Delta V_{IN}$	Line Regulation	$+5.5V \leq V_{IN} \leq +8.0V$			20	ppm/V
$\Delta V_{OUT}/\Delta I_{OUT}$	Load Regulation	Sourcing: $0mA \leq I_{OUT} \leq 10mA$ Sinking: $-10mA \leq I_{OUT} \leq 0mA$		10 20	50 100	$\mu V/mA$
$\Delta V_{OUT}/\Delta t$	Long Term Stability	$T_A = 25^\circ C$		10		ppm/ 1,000Hrs
$\Delta V_{OUT}/\Delta T_A$	Thermal Hysteresis	$\Delta T_A = 25^\circ C$ (note: 2)		10		ppm
$\Delta V_{OUT}/\Delta T_A$	Thermal Hysteresis	$\Delta T_A = 125^\circ C$ (note: 3)		50		ppm
I_{SC}	Short Circuit Current	$T_A = 25^\circ C$ (note: 4)		50	80	mA
V_N	V_{OUT} Noise	$0.1Hz \leq f \leq 10Hz$		30		$\mu Vp-p$

- Note:
- Over the specified temperature range. Temperature coefficient is measured by the box method whereby the change in V_{OUT} is divided by the temperature range; in this case, $-40^\circ C$ to $+85^\circ C = 125^\circ C$.
 - Measured change in V_{OUT} before and after changing temp by $25^\circ C$.
 - Thermal Hysteresis is the change in V_{OUT} created by package stress @ $T_A = 25^\circ C$ after temperature cycling. V_{OUT} is read initially at $T_A = 25^\circ C$; the X60008 is then cycled between Hot ($85^\circ C$) and Cold ($-40^\circ C$) before a second V_{OUT} measurement is taken at $25^\circ C$. The deviation between the initial V_{OUT} reading and the second V_{OUT} reading is then expressed in ppm.
 - Guaranteed by Device Characterization.

TYPICAL PERFORMANCE CHARACTERISTIC CURVES

($V_{IN} = 6.5V$, $I_{OUT} = 0mA$, $T_A = 25^\circ C$ unless otherwise specified)

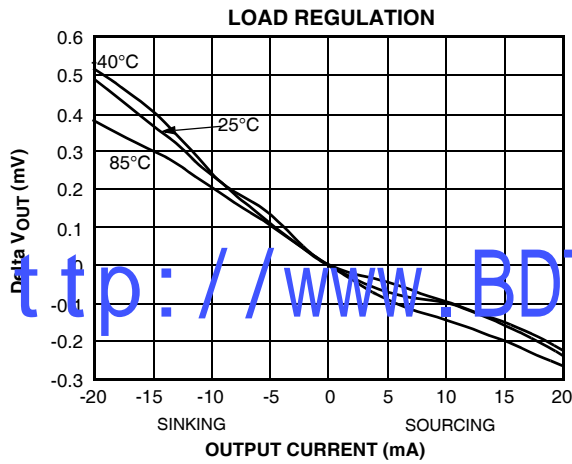
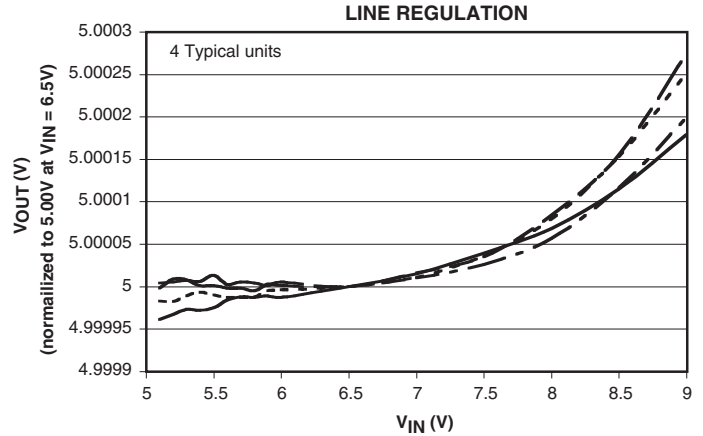
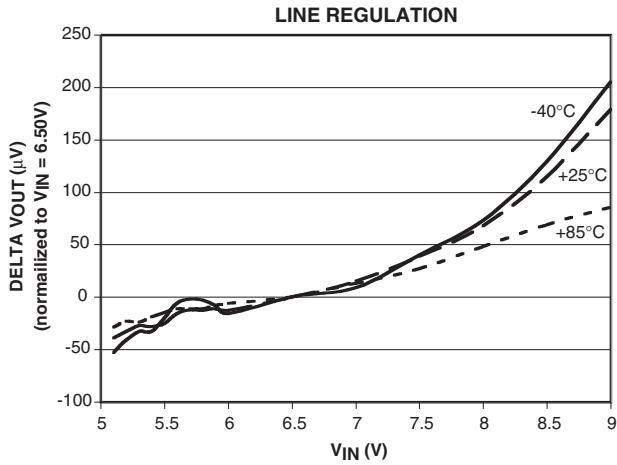

0.1Hz to 10Hz VOUT NOISE
Band Pass Filter with 1 zero at .1Hz and 2 poles at 10 Hz

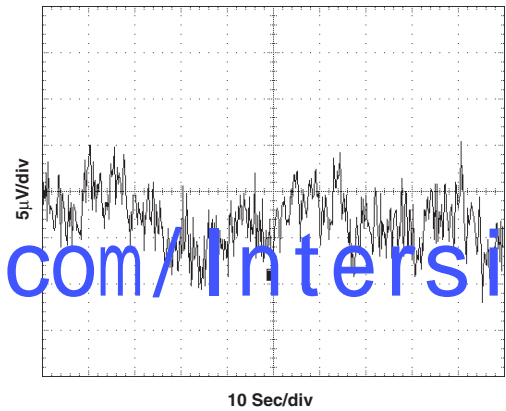

<http://www.BDTIC.com/Intersil/>

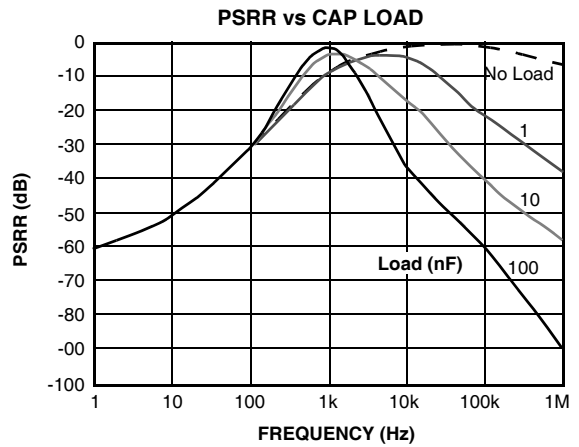
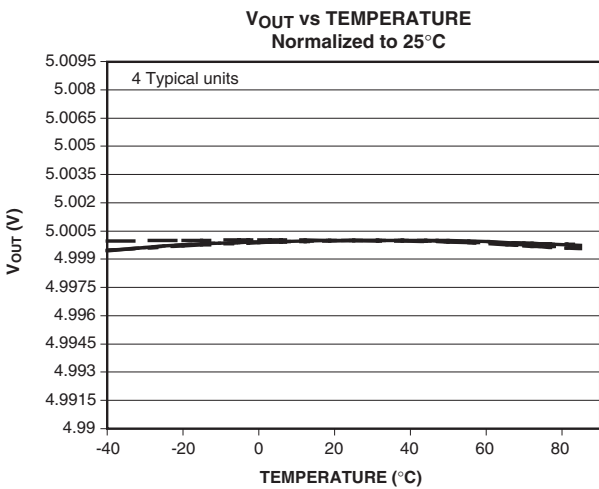

TYPICAL PERFORMANCE CHARACTERISTIC CURVES

($V_{IN} = 6.5V$, $I_{OUT} = 0mA$, $T_A = 25^\circ C$ unless otherwise specified)

10mA LOAD TRANSIENT RESPONSE

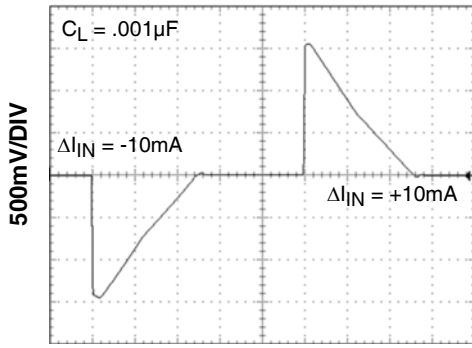

1mSEC/DIV

50µA LOAD TRANSIENT RESPONSE

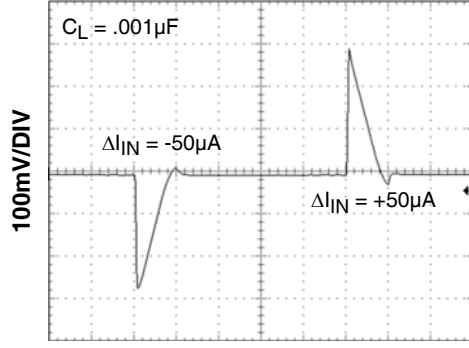

500µSEC/DIV

LINE TRANSIENT RESPONSE

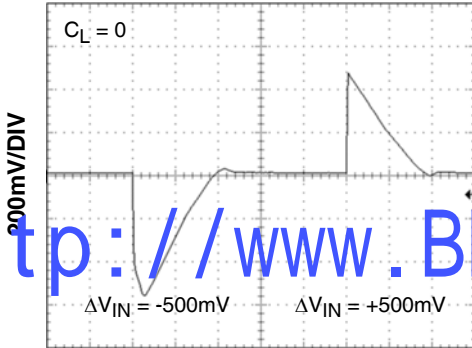

500µSEC/DIV

LINE TRANSIENT RESPONSE

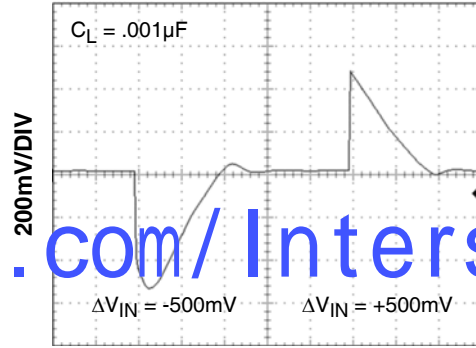

500µSEC/DIV

<http://www.BDTIC.com/Intersil>

MINIMUM V_{IN} to V_{OUT} DIFFERENTIAL vs. OUTPUT CURRENT

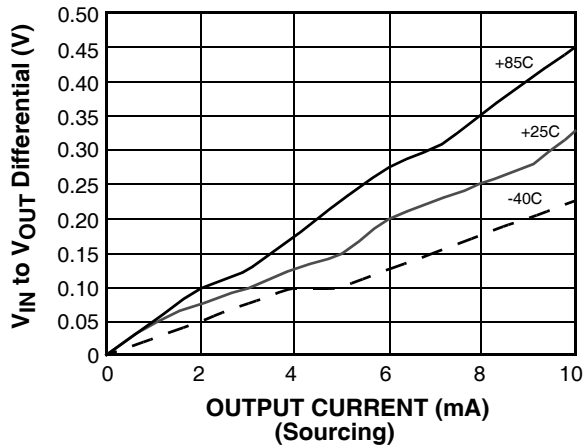

Zout vs FREQUENCY

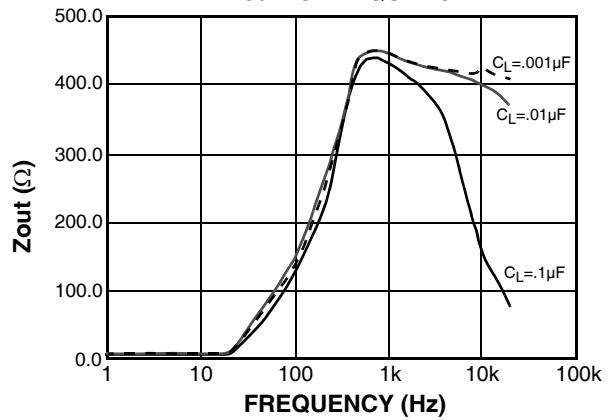

TYPICAL PERFORMANCE CHARACTERISTIC CURVES

($V_{IN} = 6.5V$, $I_{OUT} = 0mA$, $T_A = 25^\circ C$ unless otherwise specified)

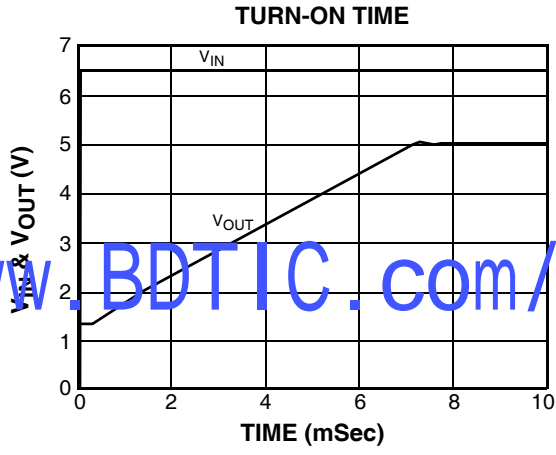
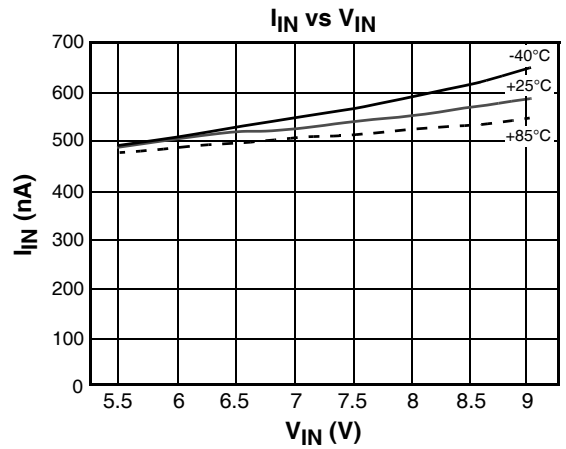
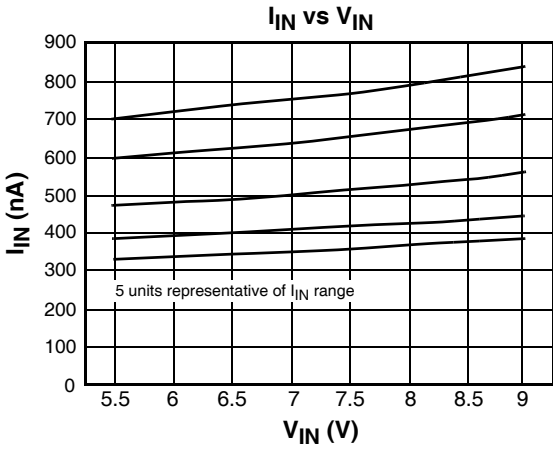

<http://www.BDTIC.com/Intersil>

APPLICATIONS INFORMATION

FGA Technology

The X60008 series of voltage references use the floating gate technology to create references with very low drift and supply current. Essentially the charge stored on a floating gate cell is set precisely in manufacturing. The reference voltage output itself is a buffered version of the floating gate voltage. The resulting reference device has excellent characteristics which are unique in the industry: very low temperature drift, high initial accuracy, and almost zero supply current. Also, the reference voltage itself is not limited by voltage bandgaps or zener settings, so a wide range of reference voltages can be programmed (standard voltage settings are provided, but customer-specific voltages are available).

The process used for these reference devices is a floating gate CMOS process, and the amplifier circuitry uses CMOS transistors for amplifier and output transistor circuitry. While providing excellent accuracy, there are limitations in output noise level and load regulation due to the MOS device characteristics. These limitations are addressed with circuit techniques discussed in other sections.

Nanopower Operation

Reference devices achieve their highest accuracy when powered up continuously, and after initial stabilization has taken place. This drift can be eliminated by leaving the power-on continuously.

The X60008 is the first high precision voltage reference with ultra low power consumption that makes it practical to leave power-on continuously in battery operated circuits. The X60008 consumes extremely low supply current due to the proprietary FGA technology. Supply current at room temperature is typically 500nA which is 1 to 2 orders of magnitude lower than competitive devices. Application circuits using battery power will benefit greatly from having an accurate, stable reference which essentially presents no load to the battery.

In particular, battery powered data converter circuits that would normally require the entire circuit to be disabled when not in use can remain powered up between conversions as shown in figure 1. Data acquisition circuits providing 12 to 24 bits of accuracy can operate with the reference device continuously biased with no power penalty, providing the highest accuracy and lowest possible long term drift.

Other reference devices consuming higher supply currents will need to be disabled in between conversions to conserve battery capacity. Absolute accuracy will

suffer as the device is biased and requires time to settle to its final value, or, may not actually settle to a final value as power-on time may be short.

Figure 1.

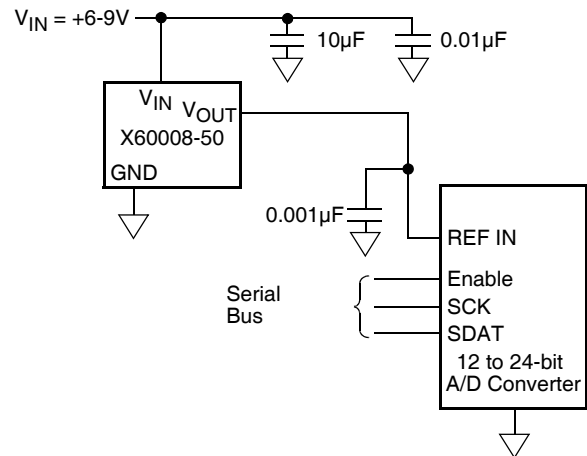

Board mounting Considerations

For applications requiring the highest accuracy, board mounting location should be reviewed. Placing the device in areas subject to slight twisting can cause degradation of the accuracy of the reference voltage due to die stresses. It is normally best to place the device near the edge of a board, or the shortest side, as the axis of bending is most limited at that location. Obviously mounting the device on flexprint or extremely thin PC material will likewise cause loss of reference accuracy.

Noise Performance and Reduction:

The output noise voltage in a 0.1Hz to 10Hz bandwidth is typically 30µVp-p. This is shown in the plot in the Typical Performance Curves. The noise measurement is made with a bandpass filter made of a 1 pole high-pass filter with a corner frequency at .1Hz and a 2-pole low-pass filter with a corner frequency at 12.6Hz to create a filter with a 9.9Hz bandwidth. Noise in the 10KHz to 1MHz bandwidth is approximately 400µVp-p with no capacitance on the output, as shown in Fig. 2 below. These noise measurements are made with a 2 decade bandpass filter made of a 1 pole high-pass filter with a corner frequency at 1/10 of the center frequency and 1-pole low-pass filter with a corner frequency at 10 times the center frequency. Figure 2 also shows the noise in the 10KHz to 1MHz band can be reduced to about 50µVp-p using a .001µF capacitor on the output. Noise in the 1KHz to 100KHz band can be further reduced using a 0.1µF capacitor on the output, but noise in the 1Hz to 100Hz band increases due to instability of the very low power amplifier with a 0.1µF capacitance load. For

load capacitances above .001 μ F the noise reduction network shown in fig. 3 is recommended. This network reduces noise significantly over the full bandwidth. As shown in fig. 2, noise is reduced to less than 40 μ Vp-p from 1Hz to 1MHz using this network with a .01 μ F capacitor and a 2k Ω resistor in series with a 10 μ F capacitor.

Figure 2.

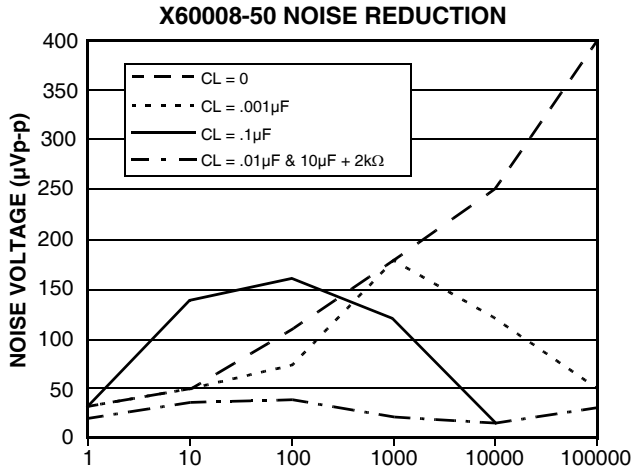
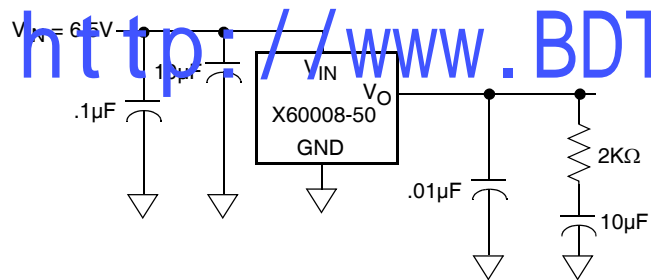

Figure 3.



Turn-On Time

The X60008 devices have ultra-low supply current and thus the time to bias up internal circuitry to final values will be longer than with higher power references. Normal turn-on time is typically 7ms. This is shown in the graph, Figure 4. Since devices can vary in supply current down to 300nA, turn-on time can last up to about 12ms. Care should be taken in system design to include this delay before measurements or conversions are started.

Figure 4.

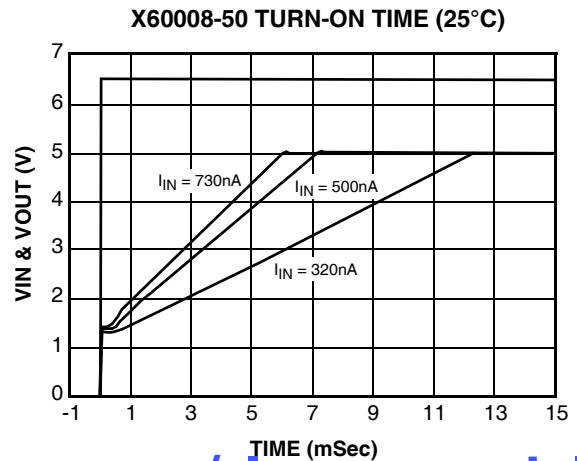

Temperature Coefficient

The limits stated for temperature coefficient (tempco) are governed by the method of measurement. The overwhelming standard for specifying the temperature drift of a reference is to measure the reference voltage at two temperatures, take the total variation, (V_{HIGH} - V_{LOW}), and divide by the temperature extremes of measurement (T_{HIGH} - T_{LOW}). The result is divided by the nominal reference voltage (at T = 25°C) and multiplied by 10⁶ to yield ppm/°C. This is the "Box" method for determining temperature coefficient.

TYPICAL APPLICATION CIRCUITS

Precision 5V, 50mA Reference.

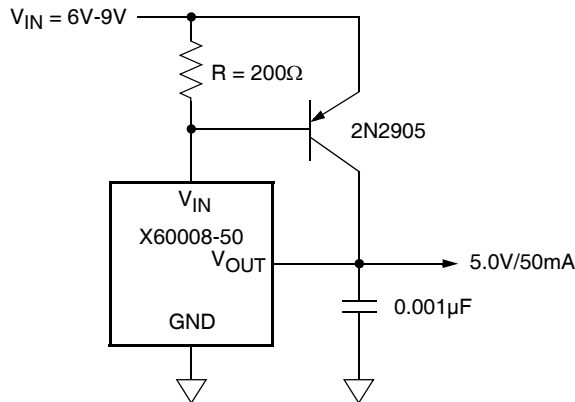

±5.0V Dual Output, High Accuracy Reference

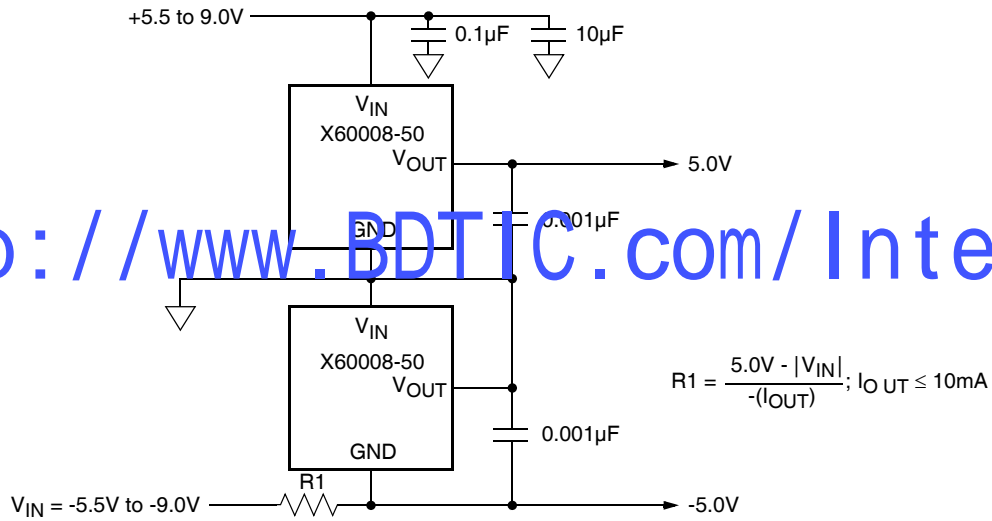

Kelvin Sensed Load

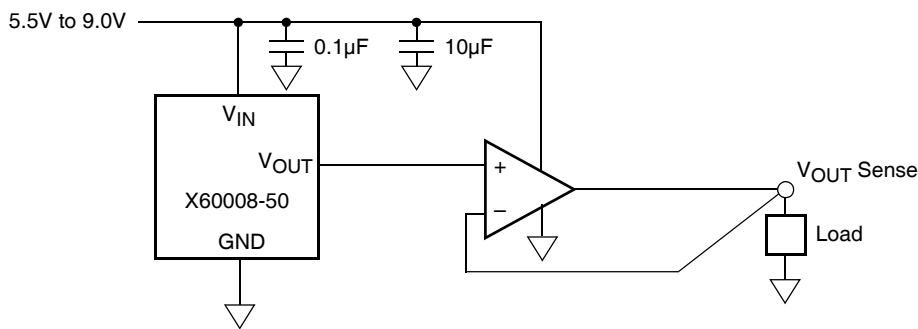

TYPICAL APPLICATION CIRCUITS

Negative Voltage Reference

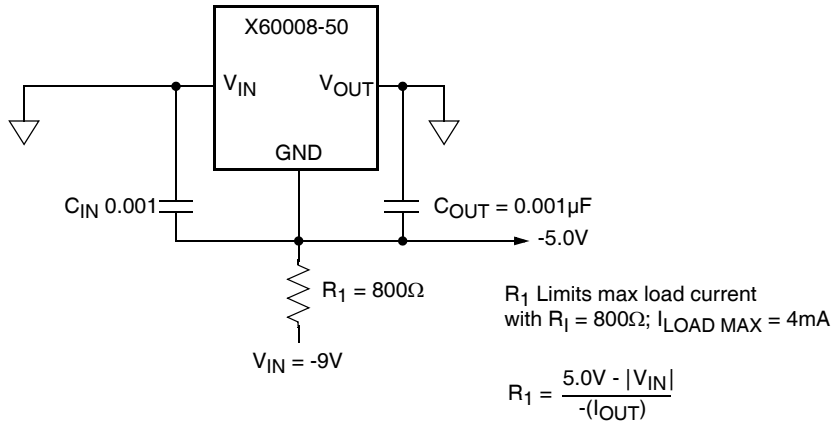

5V Full Scale Low-Drift 10-bit Adjustable Voltage Source

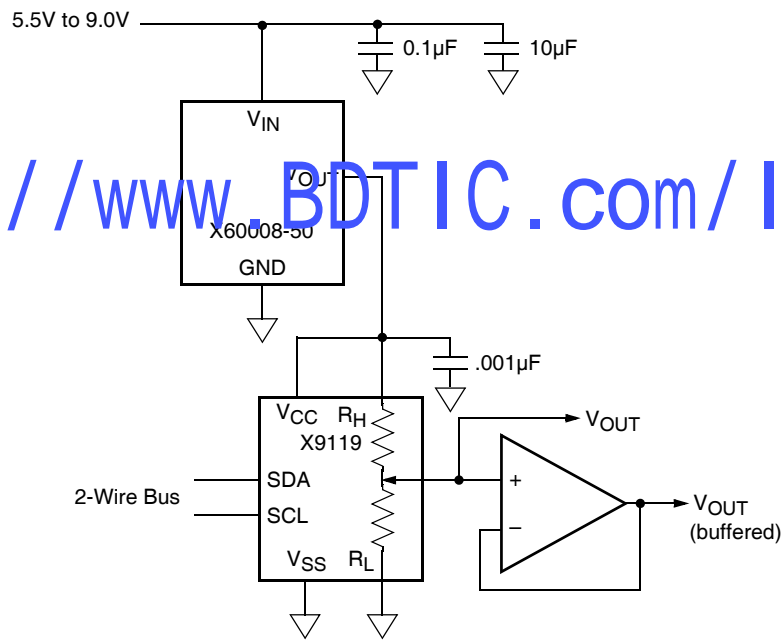

<http://www.BDTIC.com/Intersil>

Small Outline Package Family (SO)

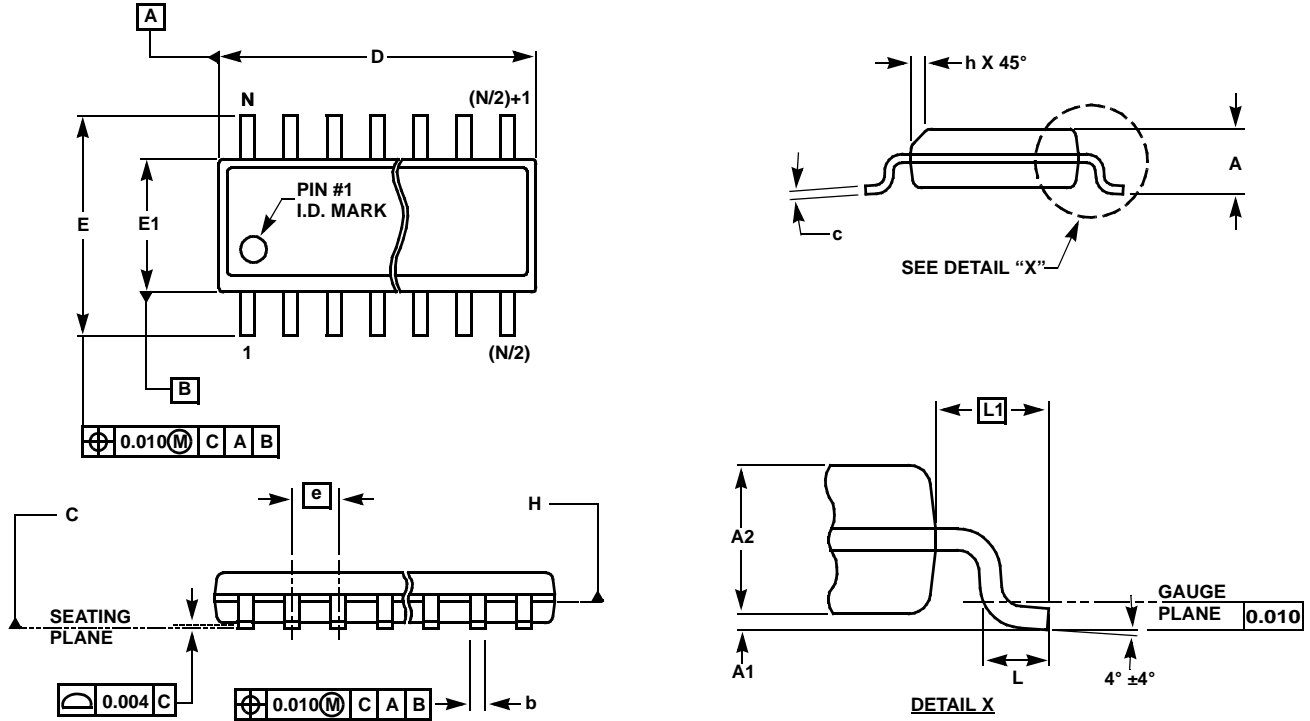

MDP0027

SMALL OUTLINE PACKAGE FAMILY (SO)

SYMBOL	SO-8	SO-14	SO16 (SOL-16)	SO16 (0.30") (SOL-16)	SO20 (SOL-20)	SO24 (SOL-24)	SO28 (SOL-28)	TOLERANCE	NOTES
A	0.068	0.068	0.068	0.104	0.104	0.104	0.104	MAX	-
A1	0.006	0.006	0.006	0.007	0.007	0.007	0.007	±0.003	-
A2	0.057	0.057	0.057	0.092	0.092	0.092	0.092	±0.002	-
b	0.017	0.017	0.017	0.017	0.017	0.017	0.017	±0.003	-
c	0.009	0.009	0.009	0.011	0.011	0.011	0.011	±0.001	-
D	0.193	0.341	0.390	0.406	0.504	0.606	0.704	±0.004	1, 3
E	0.236	0.236	0.236	0.406	0.406	0.406	0.406	±0.008	-
E1	0.154	0.154	0.154	0.295	0.295	0.295	0.295	±0.004	2, 3
e	0.050	0.050	0.050	0.050	0.050	0.050	0.050	Basic	-
L	0.025	0.025	0.025	0.030	0.030	0.030	0.030	±0.009	-
L1	0.041	0.041	0.041	0.056	0.056	0.056	0.056	Basic	-
h	0.013	0.013	0.013	0.020	0.020	0.020	0.020	Reference	-
N	8	14	16	16	20	24	28	Reference	-

Rev. L 2/01

NOTES:

1. Plastic or metal protrusions of 0.006" maximum per side are not included.
2. Plastic interlead protrusions of 0.010" maximum per side are not included.
3. Dimensions "D" and "E1" are measured at Datum Plane "H".
4. Dimensioning and tolerancing per ASME Y14.5M-1994

All Intersil U.S. products are manufactured, assembled and tested utilizing ISO9000 quality systems. Intersil Corporation's quality certifications can be viewed at www.intersil.com/design/quality

Intersil products are sold by description only. Intersil Corporation reserves the right to make changes in circuit design, software and/or specifications at any time without notice. Accordingly, the reader is cautioned to verify that data sheets are current before placing orders. Information furnished by Intersil is believed to be accurate and reliable. However, no responsibility is assumed by Intersil or its subsidiaries for its use; nor for any infringements of patents or other rights of third parties which may result from its use. No license is granted by implication or otherwise under any patent or patent rights of Intersil or its subsidiaries.

For information regarding Intersil Corporation and its products, see www.intersil.com