

MMBV2101LT1 Series, MV2105, MV2101, MV2109, LV2209

Preferred Device

Silicon Tuning Diodes

These devices are designed in popular plastic packages for the high volume requirements of FM Radio and TV tuning and AFC, general frequency control and tuning applications. They provide solid-state reliability in replacement of mechanical tuning methods. Also available in a Surface Mount Package up to 33 pF.

Features

- High Q
- Controlled and Uniform Tuning Ratio
- Standard Capacitance Tolerance – 10%
- Complete Typical Design Curves
- Pb-Free Packages are Available

MAXIMUM RATINGS

Rating	Symbol	Value	Unit
Reverse Voltage	V_R	30	Vdc
Forward Current	I_F	200	mAdc
Forward Power Dissipation @ $T_A = 25^\circ\text{C}$ MMBV21xx	P_D	225	mW
Derate above 25°C		1.8	mW/ $^\circ\text{C}$
@ $T_A = 25^\circ\text{C}$ MV21xx		280	mW
Derate above 25°C LV2209		2.8	mW/ $^\circ\text{C}$
Junction Temperature	T_J	+150	$^\circ\text{C}$
Storage Temperature Range	T_{stg}	-55 to +150	$^\circ\text{C}$

Maximum ratings are those values beyond which device damage can occur. Maximum ratings applied to the device are individual stress limit values (not normal operating conditions) and are not valid simultaneously. If these limits are exceeded, device functional operation is not implied, damage may occur and reliability may be affected.

ELECTRICAL CHARACTERISTICS ($T_A = 25^\circ\text{C}$ unless otherwise noted)

Characteristic	Symbol	Min	Typ	Max	Unit
Reverse Breakdown Voltage ($I_R = 10 \mu\text{Adc}$) MMBV21xx, MV21xx LV2209	$V_{(BR)R}$	30 25	- -	- -	Vdc
Reverse Voltage Leakage Current ($V_R = 25 \text{ Vdc}$, $T_A = 25^\circ\text{C}$)	I_R	-	-	0.1	μAdc
Diode Capacitance Temperature Coefficient ($V_R = 4.0 \text{ Vdc}$, $f = 1.0 \text{ MHz}$)	TC_C	-	280	-	ppm/ $^\circ\text{C}$



ON Semiconductor®

<http://onsemi.com>

6.8–100 pF, 30 VOLTS VOLTAGE VARIABLE CAPACITANCE DIODES

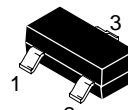
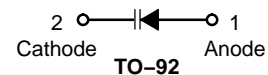
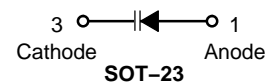

SOT-23 (TO-236)
CASE 318-08
STYLE 8

MARKING DIAGRAMS

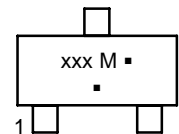

xxx = Specific Device Code

M = Date Code*

▪ = Pb-Free Package

(Note: Microdot may be in either location)

*Date Code orientation and/or overbar may vary depending upon manufacturing location.



TO-92 (TO-226AC)
CASE 182
STYLE 1

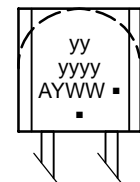

yyyyyy = Specific Device Code

A = Assembly Location

Y = Year

WW = Work Week

▪ = Pb-Free Package

(Note: Microdot may be in either location)

ORDERING INFORMATION

See detailed ordering and shipping information in the package dimensions section on page 2 of this data sheet.

Preferred devices are recommended choices for future use and best overall value.

MMBV2101LT1 Series, MV2105, MV2101, MV2109, LV2209

Device	Marking	Package	Shipping [†]	C _T , Diode Capacitance V _R = 4.0 Vdc, f = 1.0 MHz pF			Q, Figure of Merit V _R = 4.0 Vdc, f = 50 MHz	TR, Tuning Ratio C ₂ /C ₃₀ f = 1.0 MHz		
				Min	Nom	Max	Typ	Min	Typ	Max
MMBV2101LT1	M4G	SOT-23	3,000 / Tape & Reel	6.1	6.8	7.5	450	2.5	2.7	3.2
MMBV2101LT1G	M4G	SOT-23 (Pb-Free)	3,000 / Tape & Reel	6.1	6.8	7.5	450	2.5	2.7	3.2
MMBV2101L	M4G	SOT-23	Bulk (Note 1)	6.1	6.8	7.5	450	2.5	2.7	3.2
MV2101	MV2101	TO-92	1,000 per Box	6.1	6.8	7.5	450	2.5	2.7	3.2
MV2101G	MV2101	TO-92 (Pb-Free)	1,000 per Box	6.1	6.8	7.5	450	2.5	2.7	3.2
MMBV2103LT1	4H	SOT-23	3,000 / Tape & Reel	9.0	10	11	400	2.5	2.9	3.2
MMBV2105LT1	4U	SOT-23	3,000 / Tape & Reel	13.5	15	16.5	400	2.5	2.9	3.2
MMBV2105LT1G	4U	SOT-23 (Pb-Free)	3,000 / Tape & Reel	13.5	15	16.5	400	2.5	2.9	3.2
MMBV2105L	4U	SOT-23	Bulk (Note 1)	13.5	15	16.5	400	2.5	2.9	3.2
MV2105	MV2105	TO-92	1,000 per Box	13.5	15	16.5	400	2.5	2.9	3.2
MV2105G	MV2105	TO-92 (Pb-Free)	1,000 per Box	13.5	15	16.5	400	2.5	2.9	3.2
MMBV2107LT1	4W	SOT-23	3,000 / Tape & Reel	19.8	22	24.2	350	2.5	2.9	3.2
MMBV2107LT1G	4W	SOT-23 (Pb-Free)	3,000 / Tape & Reel	19.8	22	24.2	350	2.5	2.9	3.2
MMBV2107L	4W	SOT-23	Bulk (Note 1)	19.8	22	24.2	350	2.5	2.9	3.2
MMBV2108LT1	4X	SOT-23	3,000 / Tape & Reel	24.3	27	29.7	300	2.5	3.0	3.2
MMBV2108LT1G	4X	SOT-23 (Pb-Free)	3,000 / Tape & Reel	24.3	27	29.7	300	2.5	3.0	3.2
LV2209	LV2209	TO-92	1,000 per Box	29.7	33	36.3	200	2.5	3.0	3.2
MMBV2109LT1	4J	SOT-23	3,000 / Tape & Reel	29.7	33	36.3	200	2.5	3.0	3.2
MMBV2109LT1G	4J	SOT-23 (Pb-Free)	3,000 / Tape & Reel	29.7	33	36.3	200	2.5	3.0	3.2
MMBV2109L	4J	SOT-23	Bulk (Note 1)	29.7	33	36.3	200	2.5	3.0	3.2
MV2109	MV2109	TO-92	1,000 per Box	29.7	33	36.3	200	2.5	3.0	3.2
MV2109G	MV2109	TO-92 (Pb-Free)	1,000 per Box	29.7	33	36.3	200	2.5	3.0	3.2

[†]For information on tape and reel specifications, including part orientation and tape sizes, please refer to our Tape and Reel Packaging Specification Brochure, BRD8011/D.

1. **MMBV2101LT1, MMBV2105LT1, MMBV2107LT1 thru MMBV2109LT1**, are also available in bulk. Use the device title and drop the "T1" suffix when ordering any of these devices in bulk.

PARAMETER TEST METHODS

1. C_T, DIODE CAPACITANCE

(C_T = C_C + C_J). C_T is measured at 1.0 MHz using a capacitance bridge (Boonton Electronics Model 75A or equivalent).

2. TR, TUNING RATIO

TR is the ratio of C_T measured at 2.0 Vdc divided by C_T measured at 30 Vdc.

3. Q, FIGURE OF MERIT

Q is calculated by taking the G and C readings of an admittance bridge at the specified frequency and substituting in the following equations:

$$Q = \frac{2\pi f C}{G}$$

(Boonton Electronics Model 33AS8 or equivalent). Use Lead Length $\approx 1/16''$.

4. TC_C, DIODE CAPACITANCE TEMPERATURE COEFFICIENT

TC_C is guaranteed by comparing C_T at V_R = 4.0 Vdc, f = 1.0 MHz, T_A = -65°C with C_T at V_R = 4.0 Vdc, f = 1.0 MHz, T_A = +85°C in the following equation, which defines TC_C:

$$TC_C = \left| \frac{C_T(+85^\circ\text{C}) - C_T(-65^\circ\text{C})}{85 + 65} \right| \cdot \frac{10^6}{C_T(25^\circ\text{C})}$$

Accuracy limited by measurement of C_T to ± 0.1 pF.

TYPICAL DEVICE CHARACTERISTICS

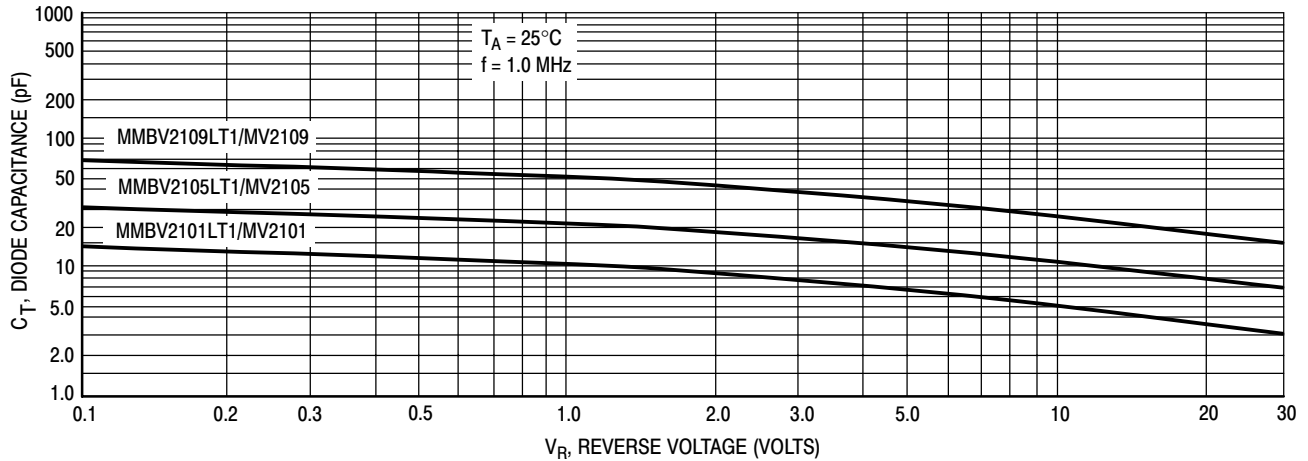

Figure 1. Diode Capacitance versus Reverse Voltage

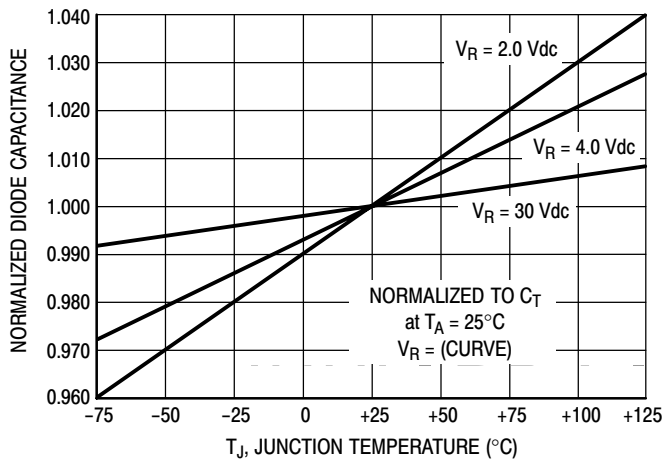

Figure 2. Normalized Diode Capacitance versus Junction Temperature

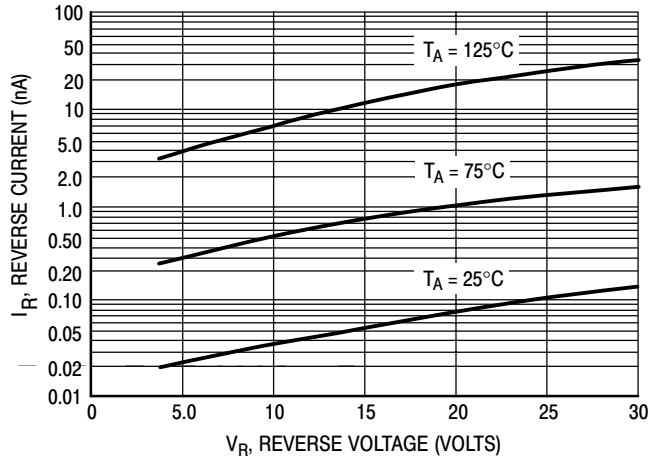

Figure 3. Reverse Current versus Reverse Bias Voltage

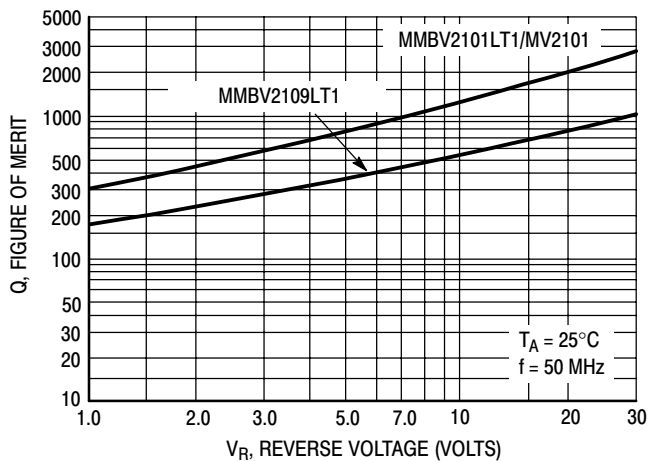

Figure 4. Figure of Merit versus Reverse Voltage

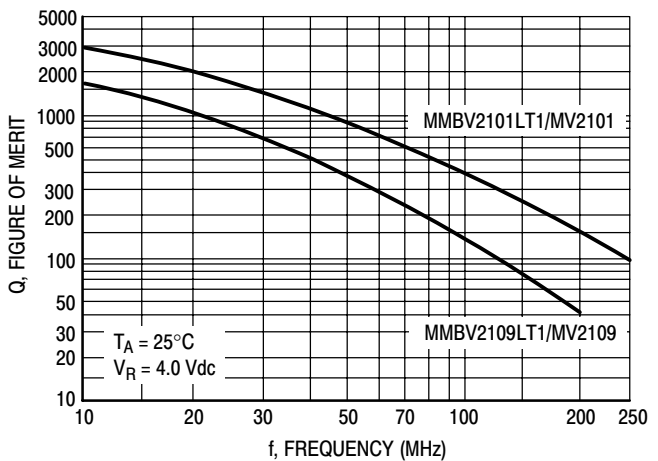
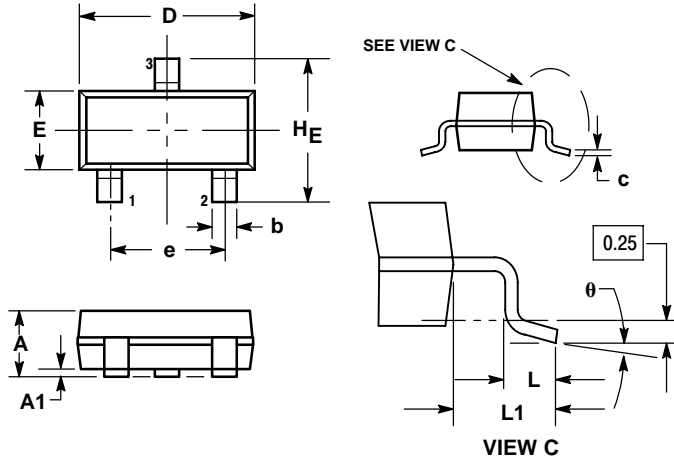

Figure 5. Figure of Merit versus Frequency

MMBV2101LT1 Series, MV2105, MV2101, MV2109, LV2209

PACKAGE DIMENSIONS

SOT-23 (TO-236)
CASE 318-08
ISSUE AN



- NOTES:
1. DIMENSIONING AND TOLERANCING PER ANSI Y14.5M, 1982.
 2. CONTROLLING DIMENSION: INCH.
 3. MAXIMUM LEAD THICKNESS INCLUDES LEAD FINISH THICKNESS. MINIMUM LEAD THICKNESS IS THE MINIMUM THICKNESS OF BASE MATERIAL.
 4. 318-01 THRU -07 AND -09 OBSOLETE, NEW STANDARD 318-08.

DIM	MILLIMETERS			INCHES		
	MIN	NOM	MAX	MIN	NOM	MAX
A	0.89	1.00	1.11	0.035	0.040	0.044
A1	0.01	0.06	0.10	0.001	0.002	0.004
b	0.37	0.44	0.50	0.015	0.018	0.020
c	0.09	0.13	0.18	0.003	0.005	0.007
D	2.80	2.90	3.04	0.110	0.114	0.120
E	1.20	1.30	1.40	0.047	0.051	0.055
e	1.78	1.90	2.04	0.070	0.075	0.081
L	0.10	0.20	0.30	0.004	0.008	0.012
L1	0.35	0.54	0.69	0.014	0.021	0.029
HE	2.10	2.40	2.64	0.083	0.094	0.104

- STYLE 8:
PIN 1. ANODE
2. NO CONNECTION
3. CATHODE

SOLDERING FOOTPRINT*

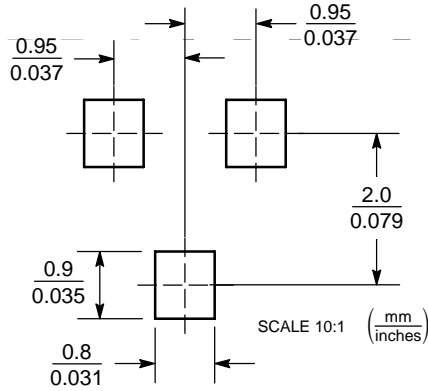

*For additional information on our Pb-Free strategy and soldering details, please download the ON Semiconductor Soldering and Mounting Techniques Reference Manual, SOLDERRM/D.

MMBV2101LT1 Series, MV2105, MV2101, MV2109, LV2209

PACKAGE DIMENSIONS

TO-92 (TO-226AC)
CASE 182-06
ISSUE L

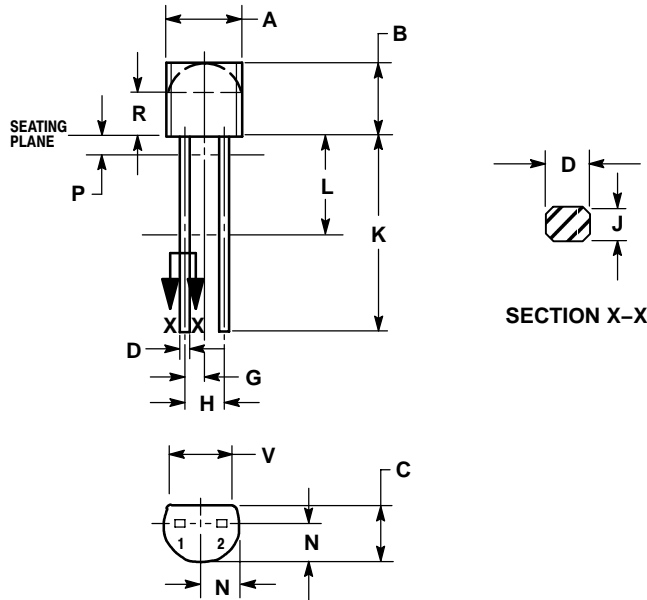

NOTES:

1. DIMENSIONING AND TOLERANCING PER ANSI Y14.5M, 1982.
2. CONTROLLING DIMENSION: INCH.
3. CONTOUR OF PACKAGE BEYOND ZONE R IS UNCONTROLLED.
4. LEAD DIMENSION IS UNCONTROLLED IN P AND BEYOND DIMENSION K MINIMUM.

DIM	INCHES		MILLIMETERS	
	MIN	MAX	MIN	MAX
A	0.175	0.205	4.45	5.21
B	0.170	0.210	4.32	5.33
C	0.125	0.165	3.18	4.19
D	0.016	0.021	0.407	0.533
G	0.050 BSC		1.27 BSC	
H	0.100 BSC		2.54 BSC	
J	0.014	0.016	0.36	0.41
K	0.500	---	12.70	---
L	0.250	---	6.35	---
N	0.080	0.105	2.03	2.66
P	---	0.050	---	1.27
R	0.115	---	2.93	---
V	0.135	---	3.43	---

STYLE 1:

- PIN 1. ANODE
- CATHODE

ON Semiconductor and are registered trademarks of Semiconductor Components Industries, LLC (SCILLC). SCILLC reserves the right to make changes without further notice to any products herein. SCILLC makes no warranty, representation or guarantee regarding the suitability of its products for any particular purpose, nor does SCILLC assume any liability arising out of the application or use of any product or circuit, and specifically disclaims any and all liability, including without limitation special, consequential or incidental damages. "Typical" parameters which may be provided in SCILLC data sheets and/or specifications can and do vary in different applications and actual performance may vary over time. All operating parameters, including "Typicals" must be validated for each customer application by customer's technical experts. SCILLC does not convey any license under its patent rights nor the rights of others. SCILLC products are not designed, intended, or authorized for use as components in systems intended for surgical implant into the body, or other applications intended to support or sustain life, or for any other application in which the failure of the SCILLC product could create a situation where personal injury or death may occur. Should Buyer purchase or use SCILLC products for any such unintended or unauthorized application, Buyer shall indemnify and hold SCILLC and its officers, employees, subsidiaries, affiliates, and distributors harmless against all claims, costs, damages, and expenses, and reasonable attorney fees arising out of, directly or indirectly, any claim of personal injury or death associated with such unintended or unauthorized use, even if such claim alleges that SCILLC was negligent regarding the design or manufacture of the part. SCILLC is an Equal Opportunity/Affirmative Action Employer. This literature is subject to all applicable copyright laws and is not for resale in any manner.

PUBLICATION ORDERING INFORMATION

LITERATURE FULFILLMENT:
Literature Distribution Center for ON Semiconductor
P.O. Box 61312, Phoenix, Arizona 85082-1312 USA
Phone: 480-829-7710 or 800-344-3860 Toll Free USA/Canada
Fax: 480-829-7709 or 800-344-3867 Toll Free USA/Canada
Email: orderlit@onsemi.com

N. American Technical Support: 800-282-9855 Toll Free
USA/Canada

Japan: ON Semiconductor, Japan Customer Focus Center
2-9-1 Kamimeguro, Meguro-ku, Tokyo, Japan 153-0051
Phone: 81-3-5773-3850

ON Semiconductor Website: <http://onsemi.com>

Order Literature: <http://www.onsemi.com/litorder>

For additional information, please contact your local Sales Representative.