



DS3100

Stratum 2/3E/3 Timing Card IC

www.maxim-ic.com

GENERAL DESCRIPTION

When paired with an external TCXO or OCXO, the DS3100 is a complete central timing and synchronization solution for SONET/SDH network elements. With two multiprotocol BITS/SSU receivers and 14 input clocks, the device directly accepts both external timing and line timing from a large number of line cards. All input clocks are continuously monitored for frequency accuracy and activity. Any two of the input clocks can be selected as the references for the two core DPLLs. The T0 DPLL complies with the Stratum 2, 3E, 3, 4E and 4 requirements of GR1244, GR-253, G.812 Types I – IV, G.813 and G.8262. From the output of the core DPLLs, a wide variety of output clock frequencies and frame pulses can be produced simultaneously on the 11 output clock pins. Two DS3100 devices can be configured in a master/slave arrangement for timing card equipment protection.

The DS3100 registers and I/O pins are backward compatible with Semtech's ACS8520 and ACS8530 timing card ICs.

APPLICATIONS

SONET/SDH ADMs, MSPPs, and MSSPs
 Digital Cross-Connects
 DSLAMs
 Service Provider Routers

FUNCTIONAL DIAGRAM

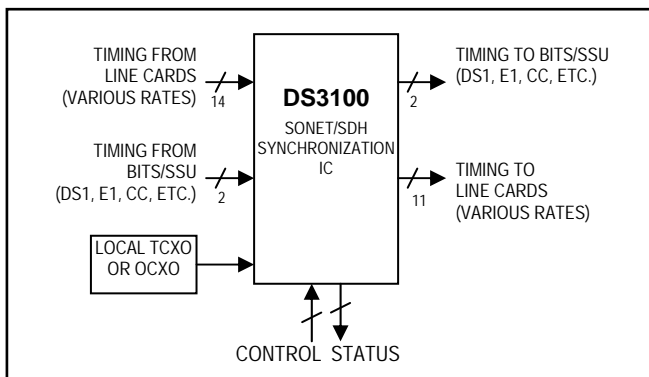

FEATURES

- **Synchronization Subsystem for Stratum 2, 3E, 3, 4E and 4 plus SMC, SEC and EEC**
 - Meets Requirements of GR-1244 Stratum 2 - 4, GR-253, G.812 Types I - IV, G.813 and G.8262
 - Stratum 2, 3E or 3 Holdover Accuracy with Suitable External Oscillator
 - Programmable Bandwidth, 0.5mHz to 70Hz
 - Hitless Reference Switching on Loss of Input
 - Phase Build-Out and Transient Absorption
 - Locks to and Generates 125MHz for Gigabit Synchronous Ethernet per ITU-T G.8261
- **14 Input Clocks**
 - 10 CMOS/TTL Inputs Accept 2kHz, 4kHz, and Any Multiple of 8kHz Up to 125MHz
 - Two LVDS/LVPECL/CMOS/TTL Inputs Accept Nx8kHz Up to 125MHz Plus 155.52MHz
 - Two 64kHz Composite Clock Receivers
 - Continuous Input Clock Quality Monitoring
 - Separate 2/4/8kHz Frame Sync Input
- **11 Output Clocks**
 - Five CMOS/TTL Outputs Drive Any Internally Produced Clock Up to 77.76MHz
 - Two LVDS Outputs Each Drive Any Internally Produced Clock Up to 311.04MHz
 - One 64kHz Composite Clock Transmitter
 - One 1.544MHz/2.048MHz Output Clock
 - Two Sync Pulses: 8kHz and 2kHz
 - Output Clock Rates Include 2kHz, 8kHz, NxDS1, NxDS2, DS3, Nx E1, E3, 6.48MHz, 19.44MHz, 38.88MHz, 51.84MHz, 62.5MHz, 77.76MHz, 125MHz, 155.52MHz, 311.04MHz
- **Two Multiprotocol BITS/SSU Transceivers**
 - Receive and Transmit DS1, E1, 2048kHz, and 6312kHz Timing Signals
 - Insert and Extract SSM Messages (DS1, E1)
 - Automatically Invalidate Clocks on LOS, OOF, AIS, and Other Defects
- **Internal Compensation for Master Clock Oscillator Frequency Accuracy**
- **Processor Interface: 8-Bit Parallel or SPI Serial**
- **1.8V Operation with 3.3V I/O (5V Tolerant)**

ORDERING INFORMATION

PART	TEMP RANGE	PIN-PACKAGE
DS3100GN	-40°C to +85°C	256 CSBGA (17mm) ²
DS3100GN+	-40°C to +85°C	256 CSBGA (17mm) ²

+ Denotes a lead(Pb)-free/RoHS-compliant package.

Note: Some revisions of this device may incorporate deviations from published specifications known as errata. Multiple revisions of any device may be simultaneously available through various sales channels. For information about device errata, click here: www.maxim-ic.com/errata.

TABLE OF CONTENTS

1. STANDARDS COMPLIANCE	7
2. BLOCK DIAGRAM	8
3. APPLICATION EXAMPLE	9
4. DETAILED DESCRIPTION	10
5. DETAILED FEATURES	12
5.1 T0 DPLL FEATURES	12
5.2 T4 DPLL FEATURES	12
5.3 INPUT CLOCK FEATURES	12
5.4 OUTPUT CLOCK FEATURES	13
5.5 REDUNDANCY FEATURES	13
5.6 BITS TRANSCIVER FEATURES	13
5.6.1 <i>General</i>	13
5.6.2 <i>Receiver</i>	13
5.6.3 <i>Transmitter</i>	14
5.7 COMPOSITE CLOCK I/O FEATURES	14
5.8 GENERAL FEATURES	14
6. PIN DESCRIPTIONS	15
7. FUNCTIONAL DESCRIPTION	24
7.1 OVERVIEW	24
7.2 DEVICE IDENTIFICATION AND PROTECTION	25
7.3 LOCAL OSCILLATOR AND MASTER CLOCK CONFIGURATION	25
7.4 INPUT CLOCK CONFIGURATION	26
7.4.1 <i>Signal Format Configuration</i>	26
7.4.2 <i>Frequency Configuration</i>	28
7.5 INPUT CLOCK QUALITY MONITORING	29
7.5.1 <i>Frequency Monitoring</i>	29
7.5.2 <i>Activity Monitoring</i>	29
7.5.3 <i>Selected Reference Activity Monitoring</i>	30
7.5.4 <i>Composite Clock Inputs</i>	30
7.6 INPUT CLOCK PRIORITY, SELECTION, AND SWITCHING	31
7.6.1 <i>Priority Configuration</i>	31
7.6.2 <i>Automatic Selection Algorithm</i>	31
7.6.3 <i>Forced Selection</i>	32
7.6.4 <i>Ultra-Fast Reference Switching</i>	32
7.6.5 <i>External Reference Switching Mode</i>	32
7.6.6 <i>Output Clock Phase Continuity During Reference Switching</i>	33
7.7 DPLL ARCHITECTURE AND CONFIGURATION	33
7.7.1 <i>T0 DPLL State Machine</i>	33
7.7.2 <i>T4 DPLL State Machine</i>	36
7.7.3 <i>Bandwidth</i>	37
7.7.4 <i>Damping Factor</i>	38
7.7.5 <i>Phase Detectors</i>	38
7.7.6 <i>Loss of Phase Lock Detection</i>	39
7.7.7 <i>Phase Monitor and Phase Build-Out</i>	40
7.7.8 <i>Input to Output Phase Adjustment</i>	41
7.7.9 <i>Phase Recalibration</i>	41
7.7.10 <i>Frequency and Phase Measurement</i>	41
7.7.11 <i>Input Wander and Jitter Tolerance</i>	42

7.7.12	<i>Jitter and Wander Transfer</i>	42
7.7.13	<i>Output Jitter and Wander</i>	43
7.8	OUTPUT CLOCK CONFIGURATION	44
7.8.1	<i>Signal Format Configuration</i>	45
7.8.2	<i>Frequency Configuration</i>	45
7.9	EQUIPMENT REDUNDANCY CONFIGURATION	54
7.9.1	<i>Master-Slave Pin Feature</i>	55
7.9.2	<i>Master-Slave Output Clock Phase Alignment</i>	55
7.9.3	<i>Master-Slave Frame and Multi-Frame Alignment with the SYNC2K Pin</i>	56
7.10	MULTIPROTOCOL BITS TRANSCEIVERS	58
7.10.1	<i>Master Clock Connections</i>	59
7.10.2	<i>Receiver Clock Connections</i>	59
7.10.3	<i>Transmitter Clock Connections</i>	61
7.10.4	<i>Line Interface Unit</i>	62
7.10.5	<i>DS1 Synchronization Interface</i>	68
7.10.6	<i>E1 Synchronization Interface</i>	70
7.10.7	<i>G.703 2048kHz Synchronization Interface</i>	72
7.10.8	<i>G.703 Appendix II 6312kHz Japanese Synchronization Interface</i>	73
7.11	COMPOSITE CLOCK RECEIVERS AND TRANSMITTER.....	74
7.11.1	<i>IC1 and IC2 Receivers</i>	75
7.11.2	<i>OC8 Transmitter</i>	75
7.12	MICROPROCESSOR INTERFACES	77
7.12.1	<i>Parallel Interface Modes</i>	77
7.12.2	<i>SPI Interface Mode</i>	77
7.13	RESET LOGIC	79
7.14	POWER-SUPPLY CONSIDERATIONS	80
7.15	INITIALIZATION	80
8.	REGISTER DESCRIPTIONS	81
8.1	STATUS BITS	81
8.2	CONFIGURATION FIELDS	81
8.3	MULTIREGISTER FIELDS	81
8.4	CORE REGISTER DEFINITIONS.....	82
8.5	BITS TRANSCEIVER REGISTER DEFINITIONS.....	147
9.	JTAG TEST ACCESS PORT AND BOUNDARY SCAN.....	198
9.1	JTAG DESCRIPTION	198
9.2	JTAG TAP CONTROLLER STATE MACHINE DESCRIPTION.....	199
9.3	JTAG INSTRUCTION REGISTER AND INSTRUCTIONS	201
9.4	JTAG TEST REGISTERS.....	202
10.	ELECTRICAL CHARACTERISTICS.....	203
10.1	DC CHARACTERISTICS.....	203
10.2	INPUT CLOCK TIMING.....	207
10.3	OUTPUT CLOCK TIMING	207
10.4	BITS TRANSCEIVER TIMING	208
10.5	PARALLEL INTERFACE TIMING	210
10.6	SPI INTERFACE TIMING.....	213
10.7	JTAG INTERFACE TIMING.....	214
11.	PIN ASSIGNMENTS	215
12.	PACKAGE INFORMATION	221
12.1	256-PIN CSBGA (17MM X 17MM)	221
13.	THERMAL INFORMATION.....	222

14. GLOSSARY223

15. ACRONYMS AND ABBREVIATIONS224

16. TRADEMARK ACKNOWLEDGEMENTS224

17. DATA SHEET REVISION HISTORY225

LIST OF FIGURES

Figure 2-1. DS3100 Block Diagram	8
Figure 3-1. Typical Application Example	9
Figure 7-1. T0 DPLL State Transition Diagram	34
Figure 7-2. T4 DPLL State Transition Diagram	37
Figure 7-3. Typical MTIE for T0 DPLL Output	43
Figure 7-4. Typical TDEV for T0 DPLL Output	44
Figure 7-5. DPLL Block Diagram	46
Figure 7-6. OC10 8kHz Options	54
Figure 7-7. BITS Transceiver Block Diagram	58
Figure 7-8. BITS Transceiver Master Clock PLL Block Diagram	59
Figure 7-9. BITS Transmitter Clock Mux Block Diagram	60
Figure 7-10. BITS Transceiver External Components	62
Figure 7-11. Jitter Tolerance, DS1 Mode	63
Figure 7-12. Jitter Tolerance, E1 and 2048kHz Modes	64
Figure 7-13. Transmit Pulse Template, DS1 Mode	66
Figure 7-14. Transmit Pulse Template, E1 Mode	66
Figure 7-15. Transmit Pulse Template, 2048kHz Mode	67
Figure 7-16. FAS/Si/RAI/Sa Source Logic	72
Figure 7-17. GR-378 Composite Clock Pulse Mask	76
Figure 7-18. SPI Clock Polarity and Phase Options	78
Figure 7-19. SPI Bus Transactions	79
Figure 9-1. JTAG Block Diagram	198
Figure 9-2. JTAG TAP Controller State Machine	200
Figure 10-1. Recommended Termination for LVDS Pins	204
Figure 10-2. Recommended Termination for LVPECL Pins	205
Figure 10-3. Recommended External Components for AMI Composite Clock Pins	206
Figure 10-4. BITS Receiver Timing Diagram	208
Figure 10-5. BITS Transmitter Timing Diagram	209
Figure 10-6. Parallel Interface Timing Diagram (Nonmultiplexed)	211
Figure 10-7. Parallel Interface Timing Diagram (Multiplexed)	212
Figure 10-8. SPI Interface Timing Diagram	213
Figure 10-9. JTAG Timing Diagram	214
Figure 11-1. DS3100 Pin Assignment—Left Half	219
Figure 11-2. DS3100 Pin Assignment—Right Half	220

LIST OF TABLES

Table 1-1. Applicable Telecom Standards.....	7
Table 6-1. Input Clock Pin Descriptions	15
Table 6-2. Output Clock Pin Descriptions.....	16
Table 6-3. BITS Receiver Pin Descriptions	17
Table 6-4. BITS Transmitter Pin Descriptions	18
Table 6-5. Global Pin Descriptions	19
Table 6-6. Parallel Interface Pin Descriptions	20
Table 6-7. SPI Bus Mode Pin Descriptions	21
Table 6-8. JTAG Interface Pin Descriptions	21
Table 6-9. General-Purpose I/O Pin Descriptions	21
Table 6-10. Power-Supply Pin Descriptions	22
Table 7-1. GR-1244 Stratum 2/3E/3 Stability Requirements.....	25
Table 7-2. Input Clock Capabilities	27
Table 7-3. Locking Frequency Modes	28
Table 7-4. Default Input Clock Priorities	31
Table 7-5. Damping Factors and Peak Jitter/Wander Gain.....	38
Table 7-6. T0 Adaptation for T4 Phase Measurement Mode	42
Table 7-7. Output Clock Capabilities	44
Table 7-8. Digital1 and Digital2 Frequencies.....	47
Table 7-9. APLL Frequency to Output Frequencies (T0 and T4).....	48
Table 7-10. T0 APLL Frequency to T0 Path Configuration	48
Table 7-11. T4 APLL Frequency to T4 Path Configuration	49
Table 7-12. OC1 to OC7 Output Frequency Selection.....	50
Table 7-13. Possible Frequencies for OC1 to OC7	50
Table 7-14. Equipment Redundancy Methodology	54
Table 7-15. Transformer Specifications.....	67
Table 7-16. DS1 Alarm Criteria.....	68
Table 7-17. E1 Alarm Criteria	70
Table 7-18. E1 Sync and Resync Criteria	70
Table 7-19. 2048kHz Synchronization Interface Specification	73
Table 7-20. 6312kHz Synchronization Interface Specification	73
Table 7-21. Composite Clock Variations	74
Table 7-22. GR-378 Composite Clock Interface Specification.....	76
Table 7-23. G.703 Synchronization Interfaces Specification.....	76
Table 7-24. Microprocessor Interface Modes	77
Table 8-1. Top-Level Memory Map.....	81
Table 8-2. Core Register Map	82
Table 8-3. BITS Transceiver Register Map	147
Table 9-1. JTAG Instruction Codes	201
Table 9-2. JTAG ID Code	202
Table 10-1. Recommended DC Operating Conditions.....	203
Table 10-2. DC Characteristics.....	203
Table 10-3. CMOS/TTL Pins	204
Table 10-4. LVDS Pins	204
Table 10-5. LVPECL Pins.....	205
Table 10-6. AMI Composite Clock Pins.....	206
Table 10-7. Recommended External Components for Output Clock OC8.....	206
Table 10-8. Input Clock Timing.....	207
Table 10-9. Input Clock to Output Clock Delay	207
Table 10-10. Output Clock Phase Alignment, Frame Sync Alignment Mode.....	207
Table 10-11. BITS Receiver Timing.....	208
Table 10-12. BITS Transmitter Timing.....	209
Table 10-13. Parallel Interface Timing.....	210
Table 10-14. SPI Interface Timing.....	213
Table 10-15. JTAG Interface Timing.....	214
Table 11-1. Pin Assignments Sorted by Signal Name.....	215
Table 13-1. Thermal Properties, Natural Convection	222

1. STANDARDS COMPLIANCE

Table 1-1. Applicable Telecom Standards

SPECIFICATION	SPECIFICATION TITLE
ANSI	
T1.101	<i>Synchronization Interface Standard, 1999</i>
T1.102	<i>Digital Hierarchy—Electrical Interfaces, 1993</i>
T1.107	<i>Digital Hierarchy—Formats Specification, 1995</i>
T1.231.02	<i>Digital Hierarchy—Layer 1 In-Service Digital Transmission Performance Monitoring, 2003</i>
T1.403	<i>Network and Customer Installation Interfaces—DS1 Electrical Interface, 1999</i>
TIA/EIA-644-A	<i>Electrical Characteristics of Low Voltage Differential Signaling (LVDS) Interface Circuits, 2001</i>
AT&T	
TR62411	<i>ACCUNET® T1.5 Service Description and Interface Specification (12/1990)</i>
ETSI	
EN 300 417-6-1	<i>Transmission and Multiplexing (TM); Generic Requirements of Transport Functionality of Equipment; Part 6-1: Synchronization Layer Functions, v1.1.3 (1999-05)</i>
EN 300 462-3-1	<i>Transmission and Multiplexing (TM); Generic Requirements for Synchronization Networks; Part 3-1: The Control of Jitter and Wander within Synchronization Networks, v1.1.1 (1998-05)</i>
EN 300 462-5-1	<i>Transmission and Multiplexing (TM); Generic Requirements for Synchronization Networks; Part 5-1: Timing Characteristics of Slave Clocks Suitable for Operation in Synchronous Digital Hierarchy (SDH) Equipment, v1.1.1 (1998-05)</i>
IEEE	
IEEE 1149.1	<i>Standard Test Access Port and Boundary-Scan Architecture, 1990</i>
ITU-T	
G.703	<i>Physical/Electrical Characteristics of Hierarchical Digital Interfaces (11/2001)</i>
G.704	<i>Synchronous Frame Structures Used at 1544, 6312, 2048, 8448 and 44736 kbit/s Hierarchical Levels (10/1998)</i>
G.706	<i>Frame Alignment and Cyclic Redundancy Check (CRC) Procedures Relating to Basic Frame Structures Defined in Recommendation G.704 (1991)</i>
G.775	<i>Loss of Signal (LOS) and Alarm Indication Signal (AIS) and Remote Defect Indication (RD) Defect Detection and Clearance Criteria for PDH Signals (10/1998)</i>
G.781	<i>Synchronization Layer Functions (06/1999)</i>
G.783	<i>ITU G.783 Characteristics of Synchronous Digital Hierarchy (SDH) Equipment Functional Blocks (10/2000 plus Amendment 1 06/2002 and Corrigendum 2 03/2003)</i>
G.812	<i>Timing Requirements of Slave Clocks Suitable for Use as Node Clocks in Synchronization Networks (06/1998)</i>
G.813	<i>Timing characteristics of SDH equipment slave clocks (SEC) (03/2003)</i>
G.823	<i>The Control of Jitter and Wander within Digital Networks which are Based on the 2048kbps Hierarchy (03/2000)</i>
G.824	<i>The Control of Jitter and Wander within Digital Networks which are Based on the 1544kbps Hierarchy (03/2000)</i>
G.825	<i>The Control of Jitter and Wander within Digital Networks which are Based on the Synchronous Digital Hierarchy (SDH) (03/2000)</i>
G.8262	<i>Timing characteristics of synchronous Ethernet equipment slave clock (EEC) (08/2007)</i>
O.162	<i>Equipment to Perform In-Service Monitoring on 2048, 8448, 34,368 and 139,264 kbit/s Signals (10/1992)</i>
TELCORDIA	
GR-253-CORE	<i>SONET Transport Systems: Common Generic Criteria, Issue 3, September 2000</i>
GR-378-CORE	<i>Generic Requirements for Timing Signal Generators, Issue 2, February 1999</i>
GR-499-CORE	<i>Transport Systems Generic Requirements (TSGR) Common Requirements, Issue 2, December 1998</i>
GR-1244-CORE	<i>Clocks for the Synchronized Network: Common Generic Criteria, Issue 2, December 2000</i>

2. BLOCK DIAGRAM

Figure 2-1. DS3100 Block Diagram

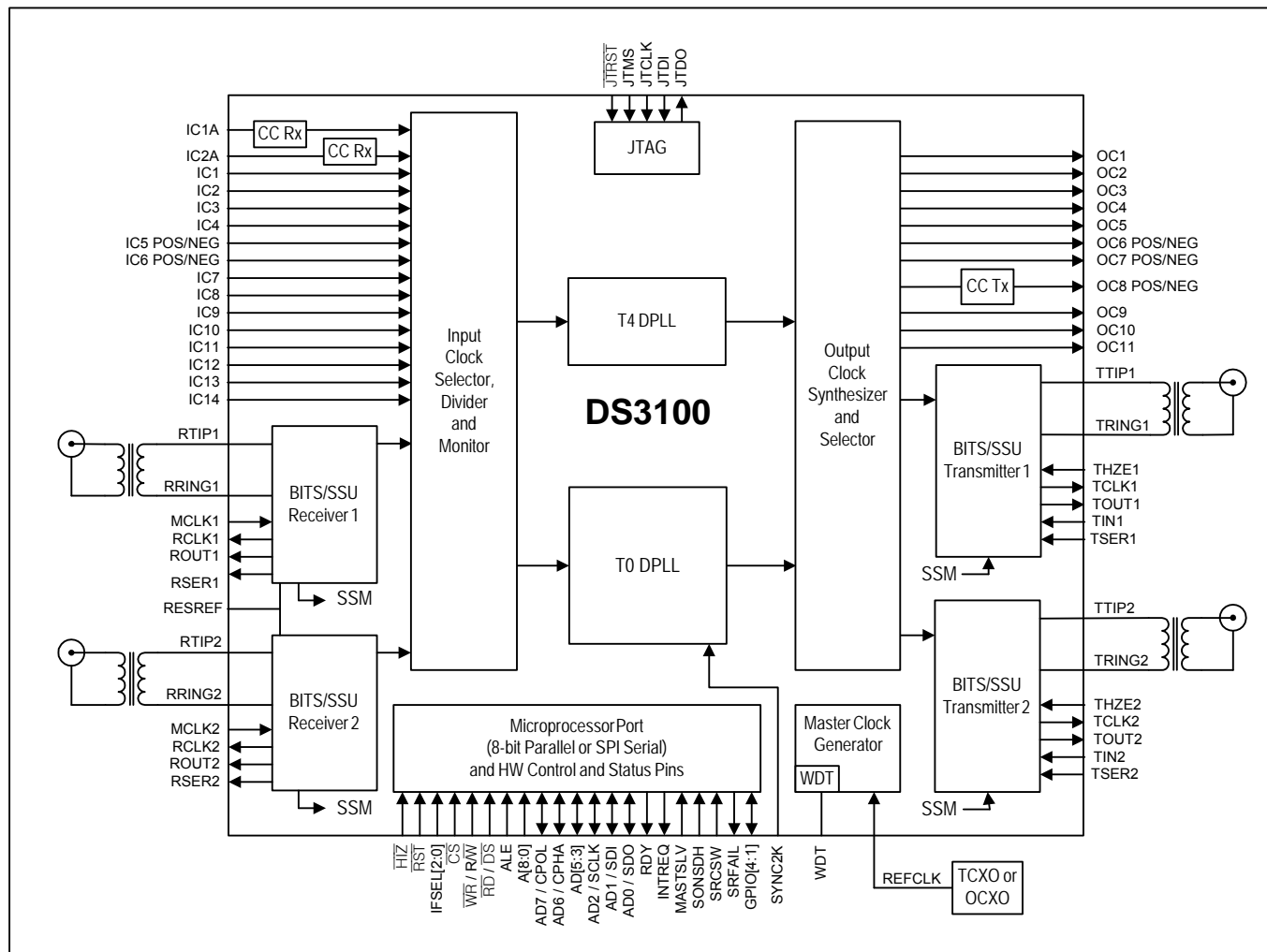

See Figure 7-5 on page 46 for a detailed view of the T0 and T4 DPLLs and the Output Clock Synthesizer and Selector block.

See Figure 7-7 on page 58 for a detailed view of the BITS Receiver and BITS Transmitter blocks.

3. APPLICATION EXAMPLE

Figure 3-1. Typical Application Example

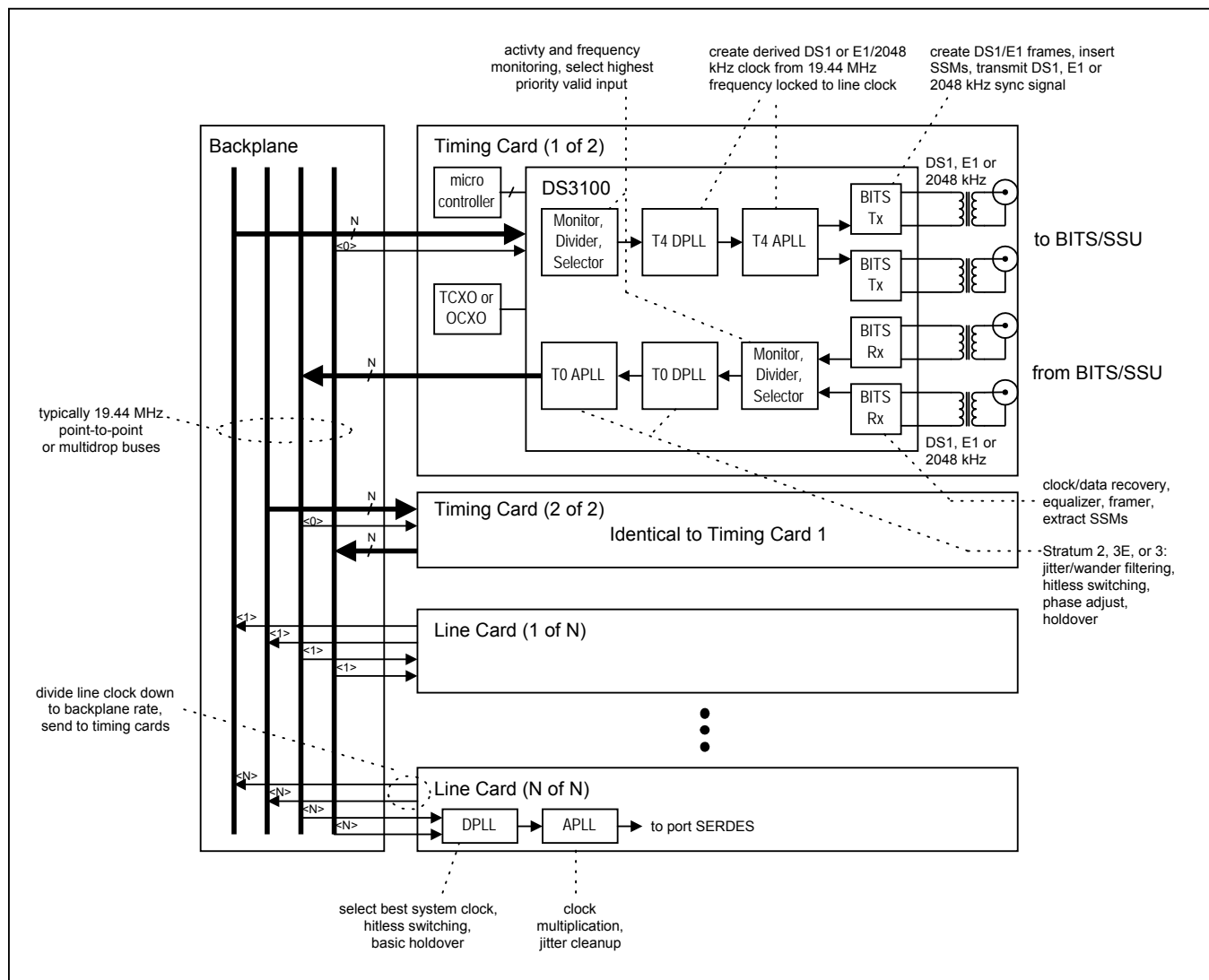

4. DETAILED DESCRIPTION

Figure 2-1 illustrates the blocks described in this section and how they relate to one another. Section 5 provides a detailed feature list.

The DS3100 is a complete timing card IC for systems with SONET/SDH ports. At the core of this device are two digital phase-locked loops (DPLLs) labeled T0 and T4¹. DPLL technology makes use of digital-signal processing (DSP) and digital-frequency synthesis (DFS) techniques to implement PLLs that are precise, flexible, and have consistent performance over voltage, temperature, and manufacturing process variations. The DS3100's DPLLs are digitally configurable for input and output frequencies, loop bandwidth, damping factor, pull-in/hold-in range, and a variety of other factors. Both DPLLs can directly lock to many common telecom frequencies and also can lock at 8kHz to any multiple of 8kHz up to 155.52MHz. The DPLLs can also tolerate and filter significant amounts of jitter and wander.

The T0 DPLL is responsible for generating the system clocks used to time the outgoing traffic interfaces of the system (SONET/SDH, synchronous Ethernet, etc.). To perform this role in a variety of systems with diverse performance requirements, the T0 DPLL has a sophisticated feature set and is highly configurable. T0 can automatically transition among free-run, locked and holdover states all without software intervention. In free-run, T0 generates a stable, low-noise clock with the same frequency accuracy as the external oscillator connected to the REFCLK pin. With software calibration the DS3100 can even improve the accuracy to within ± 0.02 ppm. When an input reference has been validated, T0 transitions to the locked state in which its output clock accuracy is equal to the accuracy of the input reference. While in the locked state, T0 acquires a high-accuracy (3.85×10^{-11}) long-term average frequency value to use as the holdover frequency. When its selected reference fails, T0 can very quickly detect the failure and enter the holdover state to avoid affecting its output clock. From holdover it can automatically switch to the next highest priority input reference, again without affecting its output clock (hitless switching). Switching among input references can be either revertive or nonrevertive. When all input references are lost, T0 stays in holdover in which it generates a stable low-noise clock with initial frequency accuracy equal to its stored holdover value and drift performance determined by the quality of the external oscillator. With a suitable local oscillator the T0 DPLL provides holdover performance suitable for all applications up to and including Stratum 2. T0 can also perform phase build-outs and fine-granularity output clock phase adjustments.

The T4 DPLL has a much less demanding role to play and therefore is much simpler than T0. Often T4 is used as a frequency converter to create a derived DS1- or E1-rate clock (frequency locked to an incoming SONET/SDH port) to be sent to a nearby BITS Timing Signal Generator (TSG, Telcordia terminology) or Synchronization Supply Unit (SSU, ITU-T terminology). In other cases T4 is phase-locked to T0 and used as a frequency converter to produce additional output clock rates for use within the system, such as NxDS1, Nx E1, NxDS2, DS3, E3, or 125MHz for synchronous Ethernet. T4 can also be configured as a measuring tool to measure the frequency of an input reference or the phase difference between two input references.

At the front end of both the T0 and T4 DPLLs is the Input Clock Selector, Divider, and Monitor (ICSDM) block. This block continuously monitors as many as 14 different input clocks of various frequencies for activity and frequency accuracy. In addition, ICSDM maintains separate input clock priority tables for the T0 and T4 DPLLs and can automatically select and provide the highest priority valid clock to each DPLL without any software intervention. The ICSDM block can also divide the selected clock down to 8kHz if required by the DPLL.

In addition to digital clock signals from system line cards, the DS3100 can also directly receive up to two 64kHz composite clock signals on its IC1A and IC2A pins and up to two DS1, E1, 2048kHz, or 6312kHz synchronization signals using its BITS receivers. These signals typically come from a nearby BITS Timing Signal Generator or SSU to provide external timing to the system. The BITS receivers are full-featured LIU receivers and framers capable of recovering clock and data from both short-haul and long-haul signals, finding DS1/E1 frame, extracting incoming SSM messages, and reporting both SSMs and performance defects (LOS, OOF, AIS, RAI) to system software. The recovered clock from each BITS receiver can be connected to any of the 14 input clocks of the ICSDM block for monitoring, optional dividing, and selection as the reference for either of the DPLLs. The BITS receivers are tightly coupled to the ICSDM block, and the DS3100 can be configured to automatically disqualify input clocks from BITS receivers (or take other actions) when defects are detected. The analog front-ends of the BITS receivers are state-

¹ These names are adapted from output ports of the SETS function specified in ITU and ETSI standards such as ETSI EN 300 462-2-1.

of-the-art LIU receivers with software-selectable termination and high-impedance inputs to support redundant timing cards without relays in the signal path.

The Output Clock Synthesizer and Selector (OCSS) block shown in [Figure 2-1](#) contains the T0 output APLL, the T4 output APLL, clock divider logic, and additional output DFS blocks. The T0 and T4 APLLs multiply the clock rates from the DPLLs by four and simultaneously attenuate jitter. Using the different settings of the T0 and T4 DPLLs and the output divider logic, the DS3100 can produce more than 60 different output frequencies including common SONET/SDH, PDH and synchronous Ethernet rates plus 2kHz and 8kHz frame pulses.

In addition to creating digital clock signals for use within the system, the DS3100 can also directly transmit one composite clock signal on its OC8 pin and up to two DS1, E1, or 2048kHz synchronization signals using its BITS transmitters. These signals typically convey the recovered timing from one SONET/SDH port to a nearby BITS timing-signal generator or SSU which in turn distributes timing to the whole central office. The BITS transmitters are full-featured frame formatters and LIU transmitters capable of generating DS1/E1 frames, inserting incoming SSM messages, and driving both short-haul and long-haul signals. Any of the output clock signals can be connected to either of the BITS transmitters for use as the transmission clock. The analog front-ends of the BITS transmitters are state-of-the-art LIU transmitters with software-selectable termination and high-impedance outputs to support redundant timing cards without relays in the signal path.

The entire chip is clocked from the external oscillator connected to the REFCLK pin. Thus the free-run and holdover stability of the DS3100-based timing card is entirely a function of the stability of the external oscillator, the performance of which can be selected to match the application: TCXO, OCXO, double-oven OCXO, etc. The 12.8MHz clock from the external oscillator is multiplied by 16 by the Master Clock Generator block to create the 204.8MHz master clock used by the rest of the device. Since every block on the device depends on the master clock and therefore the local oscillator clock for proper operation, the master clock generator has a watchdog timer (WDT) function that can be used to signal a local microprocessor in the event of a local oscillator clock failure.

The DS3100 also has several features to support master/slave timing card redundancy and protection. Two DS3100 devices on redundant cards can be configured to maintain the same priority tables, choose the same input references, and generate output clocks and frame syncs with the same frequency and phase.

5. DETAILED FEATURES

5.1 T0 DPLL Features

- High-resolution DPLL plus low-jitter output APLL
- Sophisticated state machine automatically transitions between free-run, locked, and holdover states
- Revertive or nonrevertive reference selection algorithm
- Programmable bandwidth in 18 steps from 0.5mHz to 70Hz
- Separately configurable acquisition bandwidth and locked bandwidth
- Programmable damping factor to balance lock time with peaking: 1.2, 2.5, 5, 10, or 20
- Multiple phase detectors: phase/frequency, early/late, and multicycle
- Phase/frequency locking ($\pm 360^\circ$ capture) or nearest-edge phase locking ($\pm 180^\circ$ capture)
- Multi-cycle phase detection and locking (up to $\pm 8191\text{UI}$) improves jitter tolerance and lock time
- Phase build-out in response to input phase transients (1 to 3.5 μs)
- Phase build-out in response to reference switching
- Less than 5ns output clock phase transient during phase build-out
- Output phase adjustment up to $\pm 200\text{ns}$ in 6ps steps with respect to selected input reference
- High-resolution frequency and phase measurement
- Holdover frequency averaging with 8- or 110-minute intervals
- APLL frequency options suitable for $N \times 19.44\text{MHz}$, $N \times \text{DS1}$, and $N \times \text{E1}$
- Low-jitter frame sync (8kHz) and multiframe sync (2kHz) outputs on OC10 and OC11
- 2kHz and 8kHz clocks available on OC1 through OC7 with programmable polarity and pulse width

5.2 T4 DPLL Features

- High-resolution DPLL plus low-jitter output APLL
- Programmable bandwidth: 18Hz, 35Hz, or 70Hz
- Programmable damping factor to balance lock time with peaking: 1.2, 2.5, 5, 10, or 20
- Multiple phase detectors: phase/frequency, early/late, and multicycle
- Phase/frequency locking ($\pm 360^\circ$ capture) or nearest-edge phase locking ($\pm 180^\circ$ capture)
- Multi-cycle phase detection and locking (up to $\pm 8191\text{UI}$) improves jitter tolerance and lock time
- APLL frequency options suitable for $N \times 19.44\text{MHz}$, $N \times \text{DS1}$, $N \times \text{E1}$, DS3 , E3 , 6312kHz, and $N \times 62.5\text{MHz}$ (for Gigabit Ethernet)
- 2kHz and 8kHz clocks available on OC1 through OC7 with programmable polarity and pulse width
- Can operate independently or locked to T0 DPLL
- Phase detector can be used to measure phase difference between two input clocks

5.3 Input Clock Features

- 14 input clocks
- 10 programmable-frequency CMOS/TTL input clocks accept any multiple of 8kHz up to 125MHz
- Two LVDS/LVPECL/CMOS/TTL input clocks accept any multiple of 8kHz up to 125MHz plus 155.52MHz
- Two 64kHz composite clock receivers (AMI format) that can also be configured as programmable-frequency CMOS/TTL input clocks if needed
- All 14 input clocks are constantly monitored by programmable frequency monitors and activity monitors
- Fast activity monitor can disqualify the selected reference after two missing clock cycles
- Separate 2/4/8kHz sync input

5.4 Output Clock Features

- 11 output clocks
- Five programmable-frequency CMOS/TTL output clocks drive any internally produced clock up to 77.76MHz
- Two programmable-frequency LVDS output clocks drive any internally produced clock up to 311.04MHz
- Two sync pulses, 2kHz and 8kHz, can be disciplined by a 2kHz or 8kHz sync input
- One 1.544MHz/2.048MHz output clock
- One 64kHz composite clock output (AMI format)
- Output clock rates include 2kHz, 8kHz, NxDS1, NxDS2, DS3, Nx E1, E3, 19.44MHz, 38.88MHz, 51.84MHz, 62.5MHz, 77.76MHz, 125.0MHz, 155.52MHz, and 311.04MHz
- Outputs at even divisors of 311.04MHz have less than 0.5ns peak-to-peak output jitter

5.5 Redundancy Features

- Devices on redundant timing cards can be configured for master/slave operation
- Clocks and frame syncs can be cross-wired between devices to ensure that slave always tracks master
- Master/slave mode pin can auto-configure slave to track master with no phase build-out and wider bandwidth
- Input clock priority tables can easily be kept synchronized between master and slave
- BITS transceivers have high-impedance receive inputs and transmit outputs for redundancy without relays

5.6 BITS Transceiver Features

5.6.1 General

- Two independent transceivers with fully independent transmitter and receiver
- DS1 synchronization interface in SF or ESF format
- E1 synchronization interface with FAS, CAS, and/or CRC-4 framing
- J1 support (DS1 with Japanese CRC-6 and RAI)
- 2048kHz synchronization interface (G.703)
- 6312kHz Japanese synchronization interface (G.703 Appendix II)
- Short-haul and long-haul line interface unit
- Internal software-selectable termination (75 Ω , 100 Ω , 110 Ω , or 120 Ω) or external termination
- High-impedance receive inputs and transmit outputs for relay-less master/slave redundancy
- Local and remote loopbacks

5.6.2 Receiver

- Each receiver can be connected to any of 14 input clocks
- Automatic receive sensitivity adjustment
- DS1 receive sensitivity configurable for 0 to -36dB (long haul) or 0 to -15dB (short haul)
- E1 receive sensitivity configurable for 0 to -43dB (long haul) or 0 to -12dB (short haul)
- Receive signal level indication in 2.5dB steps from -2.5dB to -34dB (DS1) and -2.5dB to -43dB (E1)
- Monitor-mode gain settings of 14dB, 20dB, 26dB, and 32dB
- LOS, OOF, RAI, and AIS status
- Extraction and validation of SSM messages from DS1 ESF data link or E1 Sa bits
- Receiver data output pin (RSER) for access to DS1/E1 payload
- Optional receiver clock and frame sync output pins (RCLK and ROUT) for special applications
- Receiver power-down control
- Short-circuit detection

5.6.3 Transmitter

- Each transmitter can be connected to any of eight output clocks
- Transmitter data input pin (TSER) for access to DS1/E1 payload
- Optional transmitter clock pins (TIN, TCLK, TOUT) for special applications
- Insertion of SSM messages into DS1 ESF data link or E1 Sa bits
- Flexible transmit waveform generation
- DSX-1 line build-outs
- E1 waveforms include G.703 waveshapes for both 75Ω coax and 120Ω twisted pair cables
- AIS and alternating ones and zeros generation
- Transmitter power-down control
- Short-circuit detection/limit
- Open-circuit detection

5.7 Composite Clock I/O Features

- Two composite clock receivers and one composite clock transmitter (all AMI format)
- Compliant with Telcordia GR-378 composite clock, G.703 centralized clock, and G.703 Appendix II.1 Japanese synchronization interfaces
- Configurable for 50% or 5/8 duty cycle, 1V or 3V pulse amplitude, and 110Ω/120Ω/133Ω termination
- Received signals are monitored for LOS, AMI violations, presence/absence of the 8 kHz component, and presence/absence of the 400Hz component (for G.703 Appendix II.1 option b)
- Transmitter can generate or suppress the 8kHz component and/or the 400 Hz component (for G.703 Appendix II.1 option b)
- Composite clock receiver inputs can be configured as programmable-frequency CMOS/TTL inputs if composite clock support is not needed

5.8 General Features

- Operates from a single external 12.800MHz local oscillator (TCXO or OCXO)
- On-chip local oscillator watchdog circuit
- Microprocessor interface can be 8-bit parallel (Intel or Motorola, multiplexed or nonmultiplexed) or SPI serial
- Register set can be write-protected

6. PIN DESCRIPTIONS

Table 6-1. Input Clock Pin Descriptions

PIN	NAME ⁽¹⁾	TYPE ⁽²⁾	FUNCTION
H1	REFCLK	I	Reference Clock. Connect to a 12.800MHz, high-accuracy, high-stability, low-noise local oscillator (TCXO or OCXO). See Section 7.3.
P6	IC1A	I	Input Clock 1 AMI. AMI 64kHz composite clock. Enabled when MCR5:IC1SF = 0. See Section 7.11.1, Table 10-6, and Table 10-3.
A10	IC1	I _{PD}	Input Clock 1. CMOS/TTL. Programmable frequency (default 8kHz). Enabled when MCR5:IC1SF = 1. See Section 7.11.1.
P7	IC2A	I	Input Clock 2 AMI. AMI 64kHz composite clock. Enabled when MCR5:IC2SF = 0. See Section 7.11.1, Table 10-6, and Table 10-3.
B10	IC2	I _{PD}	Input Clock 2. CMOS/TTL. Programmable frequency (default 8kHz). Enabled when MCR5:IC2SF = 1. See Section 7.11.1.
C10	IC3	I _{PD}	Input Clock 3. CMOS/TTL. Programmable frequency (default 8kHz).
A11	IC4	I _{PD}	Input Clock 4. CMOS/TTL. Programmable frequency (default 8kHz).
B5	IC5POS	I _A , I _A	Input Clock 5. LVDS/LVPECL or CMOS/TTL. Programmable frequency (default 19.44MHz LVDS). LVDS: See Table 10-4 and Figure 10-1. LVPECL: See Table 10-5 and Figure 10-2. CMOS/TTL: Bias IC5NEG to 1.4V and connect the single-ended signal to IC5POS.
A5	IC5NEG		
B4	IC6POS	I _A , I _A	Input Clock 6. LVDS/LVPECL. Programmable frequency (default 19.44MHz LVPECL). LVDS: See Table 10-4 and Figure 10-1. LVPECL: See Table 10-5 and Figure 10-2. CMOS/TTL: Bias IC6NEG to 1.4V and connect the single-ended signal to IC6POS.
A4	IC6NEG		
B11	IC7	I _{PD}	Input Clock 7. CMOS/TTL. Programmable frequency (default 19.44MHz).
C11	IC8	I _{PD}	Input Clock 8. CMOS/TTL. Programmable frequency (default 19.44MHz).
A12	IC9	I _{PD}	Input Clock 9. CMOS/TTL. Programmable frequency (default 19.44MHz).
B12	IC10	I _{PD}	Input Clock 10. CMOS/TTL. Programmable frequency (default 19.44MHz).
A13	IC11	I _{PD}	Input Clock 11. CMOS/TTL. Programmable frequency (default 19.44MHz in master mode, 6.48MHz in slave mode).
C12	IC12	I _{PD}	Input Clock 12. CMOS/TTL. Programmable frequency (default 1.544/2.048MHz).
B13	IC13	I _{PD}	Input Clock 13. CMOS/TTL. Programmable frequency (default 1.544/2.048MHz).
A14	IC14	I _{PD}	Input Clock 14. CMOS/TTL. Programmable frequency (default 1.544/2.048MHz).
B14	SYNC2K	I _{PD}	Frame Sync Input. 2kHz, 4kHz, or 8kHz.

Table 6-2. Output Clock Pin Descriptions

PIN	NAME ⁽¹⁾	TYPE ⁽²⁾	FUNCTION
C6	OC1	O ₃	Output Clock 1. CMOS/TTL. Programmable frequency (default 6.48MHz).
A7	OC2	O ₃	Output Clock 2. CMOS/TTL. Programmable frequency (default 38.88MHz).
B7	OC3	O ₃	Output Clock 3. CMOS/TTL. Programmable frequency (default 19.44MHz).
C7	OC4	O ₃	Output Clock 4. CMOS/TTL. Programmable frequency (default 38.88MHz).
A8	OC5	O ₃	Output Clock 5. CMOS/TTL. Programmable frequency (default 77.76MHz).
B3	OC6POS	O ₃	Output Clock 6. LVDS. Programmable frequency (default 38.88MHz LVDS). See Table 10-4 and Figure 10-1 .
A3	OC6NEG		
C2	OC7POS	O ₃	Output Clock 7. LVDS. Programmable frequency (default 19.44MHz LVDS). See Table 10-4 and Figure 10-1 .
C1	OC7NEG		
C8	OC8POS	O ₃	Output Clock 8. AMI. 64kHz composite clock. See Section 7.11.2 , Table 10-6 , and Table 10-3 .
B8	OC8NEG		
A9	OC9	O ₃	Output Clock 9. CMOS/TTL. 1.544/2.048MHz.
B9	OC10	O ₃	Output Clock 10. CMOS/TTL. 8kHz frame sync or clock.
C9	OC11	O ₃	Output Clock 11. CMOS/TTL. 2kHz multiframe sync or clock.

Table 6-3. BITS Receiver Pin Descriptions

PIN	NAME ⁽¹⁾	TYPE ⁽²⁾	PIN DESCRIPTION
F2	MCLK1	I _{PD}	Master Clock for BITS Transceiver 1. In most applications, the device's 204.8MHz master clock (see Section 7.3) is divided by 100 to get the BITS transceiver master clock. For special applications, BCCR3:MCLKS can be set to 1 to source the master clock for BITS transceiver 1 from the MCLK1 pin. The clock applied to MCLK1 can be 1X, 2X, 4X or 8X 2.048MHz for any BITS transceiver mode. For DS1 mode only, MCLK1 can be 1X, 2X, 4X, or 8X 1.544MHz. When BCCR3:MCLKS = 0, the MCLK1 pin is ignored and should be wired high or low. See Section 7.10.1.
T10	MCLK2	I _{PD}	Master Clock for BITS Transceiver 2. In most applications, the device's 204.8MHz master clock (see Section 7.3) is divided by 100 to get the BITS transceiver master clock. For special applications, BCCR3:MCLKS can be set to 1 to source the master clock for BITS transceiver 2 from the MCLK2 pin. The clock applied to MCLK2 can be 1X, 2X, 4X or 8X 2.048MHz for any BITS transceiver mode. For DS1 mode only, MCLK1 can be 1X, 2X, 4X or 8X 1.544MHz. When BCCR3:MCLKS = 0, the MCLK2 pin is ignored and should be wired high or low. See Section 7.10.1.
K1	RCLK1	O ₃	Receiver Clock Output for BITS Transceiver 1. This pin presents the recovered clock from BITS receiver 1. This output is enabled/disabled by BCCR3:RCEN . When this pin is disabled, the recovered clock can still be forwarded to one of input clocks IC1 to IC14, as specified by BCCR2:RCLKD . When disabled, RCLK1 can function as a general-purpose output whose value is controlled by BCCR3:RCINV . See Section 7.10.2.
R10	RCLK2	O ₃	Receiver Clock Output for BITS Transceiver 2. This pin presents the recovered clock from BITS receiver 2. This output is enabled/disabled by BCCR3:RCEN . When this pin is disabled, the recovered clock can still be forwarded to one of input clocks IC1 to IC14, as specified by BCCR2:RCLKD . When disabled, RCLK2 can function as a general-purpose output whose value is controlled by BCCR3:RCINV . See Section 7.10.2.
K2	ROUT1	O ₃	Receiver Multipurpose Output Pin for BITS Transceiver 1. This output is enabled/disabled by BCCR3:ROEN . Its signal source is specified by BCCR3:ROUTS . Possible sources are the DS1/E1 frame sync and the DS1/E1 multiframe sync. When disabled, ROUT1 can function as a general-purpose output whose value is controlled by BCCR3:ROINV . See Section 7.10.2.
P10	ROUT2	O ₃	Receiver Multipurpose Output Pin for BITS Transceiver 2. This output is enabled/disabled by BCCR3:ROEN . Its signal source is specified by BCCR3:ROUTS . Possible sources are the DS1/E1 frame sync and the DS1/E1 multiframe sync. When disabled, ROUT2 can function as a general-purpose output whose value is controlled by BCCR3:ROINV . See Section 7.10.2.
J3	RSER1	O ₃	Receiver Serial Data Output for BITS Transceiver 1. When BITS receiver 1 is in DS1 or E1 mode (i.e., when BMCR:RMODE = 0x), this pin presents the received DS1/E1 data stream in NRZ format. RSER1 is updated on the RCLK1 edge specified by BCCR3:RCINV . RSER1 is enabled/disabled by the BCCR3:RSEN control bit. This pin is disabled (low) in other BITS receiver modes. See Sections 7.10.5.1 and 7.10.6.1.
T11	RSER2	O ₃	Receiver Serial Data Output for BITS Transceiver 2. When BITS receiver 2 is in DS1 or E1 mode (i.e., when BMCR:RMODE = 0x), this pin presents the received DS1/E1 data stream in NRZ format. RSER2 is updated on the RCLK2 edge specified by BCCR3:RCINV . RSER2 is enabled/disabled by the BCCR3:RSEN control bit. This pin is disabled (low) in other BITS receiver modes. See Sections 7.10.5.1 and 7.10.6.1.
T5	RTIP1	I _A	Differential Receiver Inputs for BITS Transceiver 1. These pins connect to the receive cable through a 1:1 transformer. These pins are high impedance when the receiver is powered down (BLCR4:RPD = 1). See Section 7.10.4 for details.
R5	RRING1		
L16	RTIP2	I _A	Differential Receiver Inputs for BITS Transceiver 2. These pins connect to the receive cable through a 1:1 transformer. These pins are high impedance when the receiver is powered down (BLCR4:RPD = 1). See Section 7.10.4 for details.
L15	RRING2		

Table 6-4. BITS Transmitter Pin Descriptions

PIN	NAME ⁽¹⁾	TYPE ⁽²⁾	FUNCTION
L2	TCLK1	O ₃	Transmit Clock Output for BITS Transceiver 1. This pin presents the TCLK signal output from the Tx Clock Mux block. This output is enabled/disabled by BCCR4:TCEN . The TSER1 pin is sampled on the TCLK1 edge specified by BCCR4:TCINV . See Section 7.10.3.
T12	TCLK2	O ₃	Transmit Clock Output for BITS Transceiver 2. This pin presents the TCLK signal output from the Tx Clock Mux block. This output is enabled/disabled by BCCR4:TCEN . The TSER2 pin is sampled on the TCLK2 edge specified by BCCR4:TCINV . See Section 7.10.3.
M1	TOUT1	O ₃	Transmit Multipurpose Output Pin for BITS Transceiver 1. This output is enabled/disabled by BCCR4:TOEN . Its signal source is specified by BCCR4:TOUTS . Possible sources are the DS1/E1 frame sync and the DS1/E1 multiframe sync. See Section 7.10.3.
P11	TOUT2	O ₃	Transmit Multipurpose Output Pin for BITS Transceiver 2. This output is enabled/disabled by BCCR4:TOEN . Its signal source is specified by BCCR4:TOUTS . Possible sources are the DS1/E1 frame sync and the DS1/E1 multiframe sync. See Section 7.10.3.
L1	TIN1	I _{PD}	Transmitter Multipurpose Input for BITS Transceiver 1. In most applications, the BITS transmitter clock is sourced from one of output clocks OC1–OC7 or OC9, as specified by BCCR1:TCLKS . For special applications, TCLKS can be set to 0000 to enable the transmitter clock to be sourced from the TIN1 pin. Optionally TIN1 can source the frame or multiframe sync in DS1 and E1 modes. In these latter cases, TIN1 is sampled on the TCLK1 edge specified by BCCR4:TCINV . See Section 7.10.3.
R12	TIN2	I _{PD}	Transmitter Multipurpose Input for BITS Transceiver 2. In most applications, the BITS transmitter clock is sourced from one of output clocks OC1–OC7 or OC9, as specified by BCCR1:TCLKS . For special applications, TCLKS can be set to 0000 to enable the transmitter clock to be sourced from the TIN2 pin. Optionally TIN2 can source the frame or multiframe sync in DS1 and E1 modes. In these latter cases, TIN2 is sampled on the TCLK2 edge specified by BCCR4:TCINV . See Section 7.10.3.
L3	TSER1	I _{PU}	Transmitter Serial Data Input for BITS Transceiver 1. When the BITS transmitter is in DS1 or E1 mode (i.e., when BMCR:TMODE = 0x), this pin is the source for the DS1/E1 data stream in NRZ format. TSER1 is sampled on the TCLK1 edge specified by BCCR4:TCINV . Payload bits and optionally some overhead bits are sampled. Normally, this pin is wired high to achieve an all-ones payload. This pin is ignored in other BITS transmitter modes and should be held high or low. See Sections 7.10.5.2 and 7.10.6.2.
T13	TSER2	I _{PU}	Transmitter Serial Data Input for BITS Transceiver 2. When the BITS transmitter is in DS1 or E1 mode (i.e., when BMCR:TMODE = 0x), this pin is the source for the DS1/E1 data stream in NRZ format. TSER2 is sampled on the TCLK2 edge specified by BCCR4:TCINV . Payload bits and optionally some overhead bits are sampled. Normally, this pin is wired high to achieve an all-ones payload. This pin is ignored in other BITS transmitter modes and should be held high or low. See Sections 7.10.5.2 and 7.10.6.2.
R3, T3	TTIP1	O _A	Differential Transmitter Outputs for BITS Transceiver 1. These pins drive the outgoing signal onto the transmit cable through a 1:2 step-up transformer. They can be placed in a high-impedance state by pulling the THZE1 pin high or setting BLCR4:TE = 0 in BITS transceiver 1. These pins are also high impedance when the transmitter is powered down (BLCR4:TPD = 1). The two TTIP1 pins should be externally wired together, and the two TRING1 pins should be externally wired together. See Section 7.10.4.
R2, T2	TRING1		
N15, N16	TTIP2	O _A	Differential Transmitter Outputs for BITS Transceiver 2. These pins drive the outgoing signal onto the transmit cable through a 1:2 step-up transformer. They can be placed in a high-impedance state by pulling the THZE2 pin high or setting BLCR4:TE = 0 in BITS transceiver 2. These pins are also high impedance when the transmitter is powered down (BLCR4:TPD = 1). The two TTIP2 pins should be externally wired together, and the two TRING2 pins should be externally wired together. See Section 7.10.4.
P15, P16	TRING2		
K3	THZE1	I _{PU}	Transmit High-Impedance Enable for BITS Transceiver 1. See Section 7.10.4.2.3. 0 = TTIP1/TRING1 transmit data normally (must also have BLCR4:TE = 1 in BITS transceiver 1) 1 = TTIP1/TRING1 high impedance
T14	THZE2	I _{PU}	Transmit High-Impedance Enable for BITS Transceiver 2. See Section 7.10.4.2.3. 0 = TTIP2/TRING2 transmit data normally (must also have BLCR4:TE = 1 in BITS transceiver 2) 1 = TTIP2/TRING2 high impedance

Table 6-5. Global Pin Descriptions

PIN	NAME ⁽¹⁾	TYPE ⁽²⁾	FUNCTION
B6	$\overline{\text{RST}}$	I _{PU}	Active-Low Reset. When this global asynchronous reset is pulled low, all internal circuitry is reset to default values. The device is held in reset as long as $\overline{\text{RST}}$ is low. $\overline{\text{RST}}$ should be held low for at least two REFCLK cycles.
R14	$\overline{\text{HIZ}}$	I _{PU}	Active-Low High-Impedance Enable Input. The $\overline{\text{JTRST}}$ pin must be low to activate this function. 0 = Put all output pins in a high-impedance state 1 = Normal operation
N1	IFSEL0	I _{PD}	Microprocessor Interface Select. During reset, the value on these pins is latched into the IFSEL field of the IFCR register. See Section 7.12. 010 = Intel bus mode (multiplexed) 011 = Intel bus mode (nonmultiplexed) 100 = Motorola mode (nonmultiplexed) 101 = SPI mode (address and data transmitted LSB first) 110 = Motorola mode (multiplexed) 111 = SPI mode (address and data transmitted MSB first) 000, 001 = {unused value}
N2	IFSEL1		
P1	IFSEL2		
R11	MASTSLV	I _{PU}	Master/Slave Select Input. Sets the state of the MASTSLV bit in the MCR3 register. 0 = slave mode 1 = master mode
T7	RESREF	I _A	Resistor Reference. This pin must be tied to V _{SS} through a 10kΩ ±1% resistor. The BITS transceivers use this reference resistor to tune internal termination impedance values. The resistor should be placed as close as possible to the device, and capacitance on the RESREF node must be < 10pF.
M3	SONSDH	I _{PD}	SONET/SDH Frequency Select Input. Sets the reset-default state of the SONSDH bit in MCR3 , the DIG1SS and DIG2SS bits in MCR6 , and the OC9SON bit in T4CR1 . 0 = SDH rates (N x 2.048MHz) 1 = SONET rates (N x 1.544MHz)
M2	SRCSW	I _{PD}	Source Switching. Fast source switching control input. See Section 7.6.5.
J2	SRFAIL	O ₃	SRFAIL Status. When MCR10:SRFPIN = 1, this pin follows the state of the SRFAIL status bit in the MSR2 register. This gives the system a very fast indication of the failure of the current reference. When MCR10:SRFPIN = 0, SRFAIL is disabled (low).
C5	WDT	I _A	Watchdog Timer. Analog node for the REFCLK watchdog timer. Connect to a resistor (R) to V _{DDIO} and a capacitor (C) to ground. Suggested values are R = 20kΩ and C = 0.01μF. See Section 7.3.

Table 6-6. Parallel Interface Pin Descriptions

Note: These pins are active in Intel and Motorola bus modes. See Section 7.12.1 for functional description and Section 10.5 for timing specifications.

PIN	NAME ⁽¹⁾	TYPE ⁽²⁾	FUNCTION
K14	ALE	I _{PD}	Address Latch Enable. This signal controls the address latch. In nonmultiplexed bus modes, the address is latched from A[8:0]. In these modes, ALE is typically wired high to make the latch transparent. In multiplexed bus modes, the address is latched from A[8] and AD[7:0].
J16	\overline{CS}	I _{PU}	Active-Low Chip Select. This pin must be asserted (low) to read or write internal registers.
J15	$\overline{WR}/R\overline{W}$	I _{PU}	Active-Low Write Enable or Read/Active-Low Write Select. For Intel bus modes, \overline{WR} is asserted to write internal registers. For Motorola bus modes, $R\overline{W} = 1$ indicates a read and $R\overline{W} = 0$ indicates a write.
J14	$\overline{RD}/\overline{DS}$	I _{PU}	Active-Low Read Enable or Active-Low Data Strobe. For the Intel-style interface modes, \overline{RD} is asserted (low) to read internal registers. For the Motorola-style interface modes, the falling edge of \overline{DS} enables data output on AD[7:0] during reads while the rising edge of \overline{DS} latches data from AD[7:0] during writes.
E16	A[8]	I _{PD}	Address Bus. In nonmultiplexed bus modes, these inputs specify the address of the internal register to be accessed. In multiplexed bus modes, the address is specified on A[8] and AD[7:0], while A[7:0] are not used and should be wired high or low.
F15	A[7]		
G14	A[6]		
F16	A[5]		
G15	A[4]		
H14	A[3]		
G16	A[2]		
H15	A[1]		
H16	A[0]		
C14	AD[7]	I/O	Address/Data Bus. In both multiplexed and nonmultiplexed bus modes, these pins are an 8-bit data bus. In multiplexed bus modes, these pins also convey the lower 8 bits of the register address.
D14	AD[6]		
E14	AD[5]		
C15	AD[4]		
D15	AD[3]		
C16	AD[2]		
D16	AD[1]		
E15	AD[0]		
B15	\overline{RDY}	O	Active-Low Ready/Data Acknowledge. This pin is asserted when the device has completed a read or write operation.
A15	INTREQ	O	Interrupt Request. The behavior of this pin is configured in the <i>INTCR</i> register. Polarity can be active high or active low. Drive action can be push-pull or open drain. The pin can also be configured as a general-purpose output if the interrupt request function is not needed.

Table 6-7. SPI Bus Mode Pin Descriptions

Note: These pins are active in SPI interface modes. See Section 7.12.2 for functional description and Section 10.6 for timing specifications.

PIN	NAME ⁽¹⁾	TYPE ⁽²⁾	FUNCTION
J16	\overline{CS}	I _{PU}	Active-Low Chip Select. This pin must be asserted to read or write internal registers.
C16	SCLK	I	Serial Clock. SCLK is always driven by the SPI bus master.
D16	SDI	I	Serial Data Input. The SPI bus master transmits data to the device on this pin.
E15	SDO	O	Serial Data Output. The device transmits data to the SPI bus master on this pin.
D14	CPHA	I	Clock Phase. See Figure 7-18. 0 = data is latched on the leading edge of the SCLK pulse 1 = data is latched on the trailing edge of the SCLK pulse
C14	CPOL	I	Clock Polarity. See Figure 7-18. 0 = SCLK is normally low and pulses high during bus transactions 1 = SCLK is normally high and pulses low during bus transactions
A15	INTREQ	O	Interrupt Request. The behavior of this pin is configured in the INTCR register. Polarity can be active high or active low. Drive action can be push-pull or open drain. The pin can also be configured as a general-purpose output if the interrupt request function is not needed.

Table 6-8. JTAG Interface Pin Descriptions

Note: See Section 9 for functional description and Section 10.7 for timing specifications.

PIN	NAME ⁽¹⁾	TYPE ⁽²⁾	FUNCTION
T8	\overline{JTRST}	I _{PU}	Active-Low JTAG Test Reset. Asynchronously resets the test access port (TAP) controller. If not used, \overline{JTRST} can be held low or high.
R8	JTCLK	I	JTAG Clock. Shifts data into JTDI on the rising edge and out of JTDO on the falling edge. If not used, JTCLK can be held low or high.
R9	JTDI	I _{PU}	JTAG Test Data Input. Test instructions and data are clocked in on this pin on the rising edge of JTCLK. If not used, JTDI can be held low or high.
P9	JTDO	O	JTAG Test Data Output. Test instructions and data are clocked out on this pin on the falling edge of JTCLK. If not used, leave floating.
T9	JTMS	I _{PU}	JTAG Test Mode Select. Sampled on the rising edge of JTCLK and is used to place the port into the various defined IEEE 1149.1 states. If not used, connect to V _{DDIO} or leave floating.

Table 6-9. General-Purpose I/O Pin Descriptions

PIN	NAME ⁽¹⁾	TYPE ⁽²⁾	FUNCTION
E2	GPIO1	I/O	General-Purpose I/O Pin 1. GPCR :GPIO1D configures this pin as an input or an output. GPCR :GPIO1O specifies the output value. GPSR :GPIO1 indicates the state of the pin.
F3	GPIO2	I/O	General-Purpose I/O Pin 2. GPCR :GPIO2D configures this pin as an input or an output. GPCR :GPIO2O specifies the output value. GPSR :GPIO2 indicates the state of the pin.
H2	GPIO3	I/O	General-Purpose I/O Pin 3. GPCR :GPIO3D configures this pin as an input or an output. GPCR :GPIO3O specifies the output value. GPSR :GPIO3 indicates the state of the pin.
J1	GPIO4	I/O	General-Purpose I/O Pin 4. GPCR :GPIO4D configures this pin as an input or an output. GPCR :GPIO4O specifies the output value. GPSR :GPIO4 indicates the state of the pin.

Table 6-10. Power-Supply Pin Descriptions

PIN	NAME ⁽¹⁾	TYPE ⁽²⁾	FUNCTION
D6, D8, D9, D11, E6, E11, F4, F5, F12, F13, H4, H13, J4, J13, L4, L5, L12, L13, M6, M11, N6, N8, N9, N11	V _{DD}	P	Core Power Supply. 1.8V ±10%
B1, B16, D7, D10, E7–E10, G4, G5, G12, G13, H5, H12, J5, J12, K4, K5, K12, K13, M7, M8, M9, M10, N7, N10, R1, R16	V _{DDIO}	P	I/O Power Supply. 3.3V ±10%
A1, A16, D4, D5, D12, D13, E4, E5, E12, E13, F6–F11, G6–G11, H6–H11, J6–J11, K6–K11, L6–L11, M4, M5, M12, M13, N4, N5, N12, N13, T1, T16	V _{SS}	P	Ground Reference
A6	VDD_ICDIFF	P	Power Supply for LVDS Inputs (IC5 and IC6). 3.3V ±10%
C4	VSS_ICDIFF	P	Return for LVDS Inputs (IC5 and IC6)
B2	VDD_OC6	P	Power Supply for LVDS Output OC6. 1.8V ±10%
A2	VSS_OC6	P	Return for LVDS Output OC6
C3	VDD_OC7	P	Power Supply for LVDS Output OC7. 1.8V ±10%
D3	VSS_OC7	P	Return for LVDS Output OC7
T4	RVDD_P1	P	Power Supply for BITS Receiver 1. 3.3V ±10%
P5	RVSS_P1	P	Return for BITS Receiver 1
M15	RVDD_P2	P	Power Supply for BITS Receiver 2. 3.3V ±10%
M14	RVSS_P2	P	Return for BITS Receiver 2
R4	TVDD_P1	P	Power Supply for BITS Transmitter 1. 3.3V ±10%
P4	TVSS_P1	P	Return for BITS Transmitter 1
M16	TVDD_P2	P	Power Supply for BITS Transmitter 2. 3.3V ±10%
N14	TVSS_P2	P	Return for BITS Transmitter 2
D1	AVDD_PLL1	P	Power Supply for T0 Output APLL. 1.8V ±10%
D2	AVSS_PLL1	P	Return for T0 Output APLL
E1	AVDD_PLL2	P	Power Supply for T4 Output APLL. 1.8V ±10%
E3	AVSS_PLL2	P	Return for T4 Output APLL.
F1	AVDD_PLL3	P	Power Supply for T0 Feedback APLL. 1.8V ±10%
G2	AVSS_PLL3	P	Return for T0 Feedback APLL
G1	AVDD_PLL4	P	Power Supply for Master Clock Generator APLL. 1.8V ±10%
G3	AVSS_PLL4	P	Return for Master Clock Generator APLL

PIN	NAME ⁽¹⁾	TYPE ⁽²⁾	FUNCTION
H3	DV _{DD}	P	Power Supply for BITS Transceiver LIU Digital Logic. 3.3V ±10%
P8	DV _{SS}	P	Return for BITS Transceiver LIU Digital Logic
TM1	R13	—	Connect to V _{SS}
TM2	T15		
C13, F14, P12	N.C.	—	NoConnection
TST_RA1	R6		
TST_RB1	T6		
TST_RC1	R7		
TST_RA2	L14		
TST_RB2	K16		
TST_RC2	K15		
TST_TA1	P2		
TST_TB1	N3		
TST_TC1	P3		
TST_TA2	R15		
TST_TB2	P13		
TST_TC2	P14		

Note 1: All pin names with an overbar (e.g., \overline{CS}) are active low.

Note 2: All pins, except power and analog pins, are CMOS/TTL, unless otherwise specified in the pin description.

I = input pin

O = output pin

I_A = analog input pin

O_A = analog output pin (can be placed in a high-impedance state)

I_{PD} = input pin with internal 50kΩ pulldown

O₃ = output pin that can tri-stated (i.e., placed in a high-impedance state)

I_{PU} = input pin with internal 50kΩ pullup to approx.2.2V

P = power-supply pin

I/O = input/output pin

Note 3: All digital pins are I/O pins in JTAG mode.

Note 4: When ramping power supplies up or down, the voltage on any 1.8V power supply pin must not exceed the voltage on any 3.3V power-supply pin.

7. FUNCTIONAL DESCRIPTION

7.1 Overview

The DS3100 has 14 input clocks, 11 output clocks, two multiprotocol BITS/SSU receivers, and two multiprotocol BITS/SSU transmitters. There are two separate DPLL paths in the device: the high-performance T0 path and the simpler T4 path. See [Figure 2-1](#).

Two of the 14 input clocks are 64kHz composite clock receivers (by default), two are LVDS/LVPECL, and 10 are CMOS/TTL (5V tolerant). The composite clock receivers can be converted to CMOS/TTL inputs as needed. The CMOS/TTL inputs can accept signals from 2kHz to 125MHz. The LVDS/LVPECL pins can accept clock signals up to 155.52MHz.

The two BITS receivers can receive several synchronization signals including DS1, E1, 2048kHz, and 6312kHz. In DS1 and E1 modes, a built-in framer finds frame sync and extracts the incoming SSM message for inspection by system software. Each of the two BITS receivers can be connected to any one of the 14 inputs clocks.

Each input clock can be monitored continually for activity and/or frequency. Frequency can be compared to both a hard limit and a soft limit. Inputs outside the hard limit are declared invalid, while inputs inside the hard limit but outside the soft limit are merely flagged. Each input can be marked unavailable or given a priority number. Separate input priority numbers are maintained for the T0 DPLL and the T4 DPLL. Except in special modes, the highest priority valid input is automatically selected as the reference for each path.

Both the T0 and T4 DPLLs can directly lock to many common telecom frequencies, including, but not limited to 8kHz, DS1, E1, 19.44MHz, and 38.88MHz. The DPLLs can also lock to any multiple of 8kHz up to 125MHz.

The T0 DPLL is the high-performance path with all the features for node timing synchronization. The T4 DPLL is a simpler auxiliary path typically used to provide derived DS1s, E1s, or other synchronization signals to an external BITS/SSU. The two paths can be operated independently or locked together.

Both DPLLs have these features:

- Automatic reference selection based on input quality and priority
- Optional manual reference selection/forcing
- Configurable quality thresholds for each input
- Adjustable PLL characteristics, including bandwidth, pull-in range, and damping factor
- Ability to lock to several common telecom frequencies plus multiples of 8kHz up to 155.52MHz
- Frequency conversion between input and output using digital frequency synthesis
- Combined performance of a stable, consistent digital PLL and a low-jitter analog output PLL

The T0 DPLL has these additional features not available in the T4 DPLL:

- A full state machine for automatic transitions among free-run, locked, and holdover states
- Nonrevertive reference switching mode
- Phase build-out for reference switching (“hitless”) and for phase hits on the selected reference
- Output vs. input phase offset control
- 18 bandwidth selections from 0.5mHz to 70Hz (vs. three selections for the T4 path)
- Noise rejection circuitry for low-frequency references
- Optional software control over holdover frequency
- Output phase alignment to input frame sync signal
- Several frequency averaging methods for acquiring the holdover frequency

The T4 DPLL has these additional features not available in the T0 DPLL:

- Optional mode to lock to the T0 DPLL
- Optional mode to measure the phase difference between two input clocks
- Ability to generate DS3, E3, 6312kHz, and N x 62.5MHz (Gigabit Ethernet) frequencies

Typically the internal state machine controls the T0 DPLL, but manual control by system software is also available. The T4 DPLL has a simpler state machine that software cannot directly control. In either DPLL, however, software can override the DPLL logic using manual reference selection.

The T0 DPLL always operates at 77.76MHz, regardless of the output frequencies selected for the output clock pins. The T4 DPLL can operate at any of several frequencies in order to support generation of frequencies such as 44.736MHz (DS3) and 34.368MHz (E3). When the T4 DPLL is locked to the T0 DPLL, it locks to an 8kHz signal from T0 to ensure synchronization of all possible T4 frequencies, which are always multiples of 8kHz.

The outputs of the T0 and T4 DPLLs are connected to high-speed APLLs that multiply the DPLL clock rate and filter DPLL output jitter. The outputs of the APLLs are divided down to make a wide variety of possible frequencies available at the output clock pins. All or some of the output frequencies of the T0 DPLL can be synchronized to an input 2kHz, 4kHz, or 8kHz sync signal (SYNC2K pin). This synchronization to a low-frequency input enables, among other things, two redundant timing cards to maintain output phase alignment with one another.

Seven of the output clocks can be configured for a variety of different frequencies from either the T0 DPLL or the T4 DPLL. One output clock is a 64kHz composite clock transmitter (AMI format), one is 1544kHz or 2048kHz, one is 8kHz, and one is 2kHz. Of the seven multifrequency outputs, five are CMOS/TTL and two are LVDS. Altogether more than 60 output frequencies are possible, ranging from 2kHz to 311.04MHz.

The two BITS transmitters can transmit DS1, E1, and 2048kHz synchronization signals. In DS1 and E1 modes, a built-in frame formatter frames the signal and inserts the outgoing SSM message. Each of the two BITS transmitters can be connected to any of nine output clocks.

7.2 Device Identification and Protection

The 16-bit read-only ID field in the **ID1** and **ID2** registers is set to 0C1Ch = 3100 decimal. The device revision can be read from the **REV** register. Contact the factory to interpret this value and determine the latest revision. The register set can be protected from inadvertent writes using the **PROT** register.

7.3 Local Oscillator and Master Clock Configuration

The T0 and T4 DPLL paths operate from a 204.8MHz master clock. The master clock is synthesized from a 12.800MHz clock originating from a local oscillator attached to the REFCLK pin. The stability of the T0 DPLL in holdover is equivalent to the stability of the local oscillator. Selection of an appropriate local oscillator is, therefore, of crucial importance if the telecom standards listed in [Table 1-1](#) are to be met. TCXOs can be used in less stringent cases, but OCXOs are required in the most demanding applications. Even OCXOs may need to be shielded to avoid slow frequency changes due to ambient temperature fluctuations and drift. Careful evaluation of the local oscillator component is necessary to ensure proper performance. Contact Maxim at www.maxim-ic.com/support for recommended oscillators. For reference, the Telcordia GR-1244-CORE stability requirements for Stratum 2, Stratum 3E and Stratum 3 are listed in [Table 7-1](#).

Table 7-1. GR-1244 Stratum 2/3E/3 Stability Requirements

PARAMETER	STRATUM 2	STRATUM 3E	STRATUM 3
Temperature	n/a	$\pm 10 \times 10^{-9}$	$\pm 280 \times 10^{-9}$
Drift (non-temp)	$\pm 1 \times 10^{-10}/\text{day}$	$\pm 1.16 \times 10^{-14}/\text{sec}$ ($\pm 1 \times 10^{-9}/\text{day}$)	$\pm 4.63 \times 10^{-13}/\text{sec}$ ($\pm 40 \times 10^{-9}/\text{day}$)

Note: See GR-1244-CORE for additional details.

The stability of the local oscillator is very important, but its absolute frequency accuracy is less important because the DS3100 can compensate for frequency inaccuracies when synthesizing the 204.8MHz master clock from the local oscillator clock. The MCLKFREQ field in registers **MCLK1** and **MCLK2** specifies the frequency adjustment to be applied. The adjust can be from -771ppm to +514ppm in 0.0196229ppm (i.e., ~0.02ppm) steps.

The DS3100 implements a stand-alone watchdog circuit that causes an interrupt on the INTREQ pin when the local oscillator attached to the REFCLK pin is significantly off frequency. The watchdog interrupt is not maskable, but *is* subject to the [INTCR](#) register settings. When the watchdog circuit activates, reads of any and all registers in the device will return 00h to indicate the failure. In response to the activation of the INTREQ pin or during periodic polling, if system software ever reads 00h from the [ID](#) registers (which are hard-coded to 0C1Ch = 3100 decimal) then it can conclude that the local oscillator attached to that DS3100 has failed. For proper operation of the watchdog timer, connect the WDT pin to a resistor (R) to V_{DDIO} and a capacitor (C) to ground. Suggested values are $R = 20k\Omega$ and $C = 0.01\mu F$.

7.4 Input Clock Configuration

The DS3100 has 14 input clocks: IC1 to IC14. [Table 7-2](#) provides summary information about each clock, including signal format and available frequencies. The device tolerates a wide range of duty cycles on input clocks, out to a minimum high time or minimum low time of 3ns or 30% of the clock period, whichever is smaller.

7.4.1 Signal Format Configuration

Inputs with CMOS/TTL signal format accept both TTL and 3.3V CMOS levels. One key configuration bit that affects the available frequencies is the SONSDH bit in [MCR3](#). When SONSDH = 1 (SONET mode), the 1.544MHz frequency is available. When SONSDH = 0 (SDH mode), the 2.048MHz frequency is available. During reset, the default value of this bit is latched from the SONSDH pin.

Input clocks IC5 and IC6 can be configured to accept LVDS, LVPECL, or CMOS/TTL signals by using the proper set of external components. The recommended LVDS termination is shown in [Figure 10-1](#), and the LVDS electrical specifications are listed in [Table 10-4](#). The recommended LVPECL termination is shown in [Figure 10-2](#), and the LVPECL electrical specifications are listed in [Table 10-5](#). To configure these differential inputs to accept single-ended CMOS/TTL signals, use a voltage-divider to bias the ICxNEG pin to approximately 1.4V and connect the single-ended signal to the ICxPOS pin. If IC5 or IC6 is not used it should be configured for LVDS and left floating (one input is internally pulled high and the other internally pulled low). (See also [MCR5:IC5SF](#) and [IC6SF](#).)

By default, input clocks IC1 and IC2 are 64kHz composite clock receivers (see [Section 7.11](#)). The composite clock signal is a 64kHz AMI clock with an embedded 8kHz clock indicated by deliberate bipolar violations (BPs) every 8 clock cycles. The 8kHz component is the clock that is forwarded to the DLLs. The AMI composite clock electrical specifications are shown in [Table 10-6](#), and the recommended external components are shown in [Table 10-3](#). IC1 and IC2 can be configured as standard CMOS/TTL inputs (identical to IC3) by setting [MCR5:IC1SF](#) = 1 or [MCR5:IC2SF](#) = 1, respectively.

Table 7-2. Input Clock Capabilities

INPUT CLOCK	SIGNAL FORMATS	FREQUENCIES	DEFAULT FREQUENCY
IC1	AMI or CMOS/TTL ⁽³⁾	64kHz composite clock or up to 125MHz	8kHz
IC2	AMI or CMOS/TTL ⁽³⁾	64kHz composite clock or up to 125MHz	8kHz
IC3	CMOS/TTL	Up to 125MHz ⁽¹⁾	8kHz
IC4	CMOS/TTL	Up to 125MHz	8kHz
IC5	LVDS/LVPECL or CMOS/TTL	Up to 155.52MHz ⁽²⁾	19.44MHz
IC6	LVDS/LVPECL or CMOS/TTL	Up to 155.52MHz	19.44MHz
IC7	CMOS/TTL	Up to 125MHz	19.44MHz
IC8	CMOS/TTL	Up to 125MHz	19.44MHz
IC9	CMOS/TTL	Up to 125MHz	19.44MHz
IC10	CMOS/TTL	Up to 125MHz	19.44MHz
IC11	CMOS/TTL	Up to 125MHz	Master mode (MASTSLV = 1): 19.44MHz Slave mode (MASTSLV = 0): 6.48MHz
IC12	CMOS/TTL	Up to 125MHz	SONET mode (SONSDH = 1): 1.544MHz SDH mode (SONSDH = 0): 2.048MHz
IC13	CMOS/TTL	Up to 125MHz	SONET mode (SONSDH = 1): 1.544MHz SDH mode (SONSDH = 0): 2.048MHz
IC14	CMOS/TTL	Up to 125MHz	SONET mode (SONSDH = 1): 1.544MHz SDH mode (SONSDH = 0): 2.048MHz

Note 1: Available frequencies for CMOS/TTL input clocks are 2kHz, 4kHz, 8kHz, 1.544MHz (SONET mode), 2.048MHz (SDH mode), 6.312MHz, 6.48MHz, 19.44MHz, 25.92MHz, 38.88MHz, 51.84MHz, 77.76MHz, and N x 8kHz for $2 \leq N \leq 15,625$.

Note 2: Available frequencies for LVDS/LVPECL input clocks include all CMOS/TTL frequencies in Note 1 plus 155.52MHz.

Note 3: Signal formats for IC1 and IC2 are controlled by MCR5:IC1SF and IC2SF, respectively.

7.4.2 Frequency Configuration

Input clock frequencies are configured in the **FREQ** field of the **ICR** registers. The **DIVN** and **LOCK8K** bits of these same registers specify the locking frequency mode, as shown in [Table 7-3](#).

Table 7-3. Locking Frequency Modes

DIVN	LOCK8K	LOCKING FREQUENCY MODE
0	0	Direct lock mode
0	1	LOCK8K mode
1	X	DIVN mode

7.4.2.1 Direct Lock Mode

In direct lock mode, the DPLLs lock to the selected reference at the frequency specified in the corresponding **ICR** register. Direct lock mode can only be used for input clocks with these specific frequencies: 2kHz, 4kHz, 8kHz, 1.544MHz, 2.048MHz, 6.312MHz, 6.48MHz, 19.44MHz, 25.92MHz, 38.88MHz, 51.84MHz, 77.76MHz, and 155.52MHz. For the 155.52MHz case, the input clock is internally divided by two, and the DPLL direct-locks at 77.76 MHz.

The T0 DPLL can direct-lock to all the specific input frequencies listed above, and so can the T4 DPLL when configured for 77.76MHz operation (see [Section 7.8.2.2](#)). When configured for *non-77.76MHz* operation, the T4 DPLL can direct-lock to any of the specific frequencies listed above from 2kHz to 6.48MHz, but for the specific frequencies of 19.44MHz and higher, the input must be configured for LOCK8K or DIVN mode.

MTIE may be somewhat lower in direct lock mode because the higher frequencies allow more frequent phase updates.

7.4.2.2 LOCK8K Mode

In LOCK8K mode, an internal divider is configured to divide the selected reference down to 8kHz. The DPLLs lock to the 8kHz output of the divider. LOCK8K mode can only be used for input clocks with these frequencies: 8kHz, 1.544MHz, 2.048MHz, 6.312MHz, 6.48MHz, 19.44MHz, 25.92MHz, 38.88MHz, 51.84MHz, 77.76MHz, and 155.52MHz. LOCK8K mode is enabled for a particular input clock by setting the LOCK8K bit in the corresponding **ICR** register. LOCK8K mode gives a greater tolerance to input jitter because it uses lower frequencies for phase comparisons. The clock edge to lock to on the selected reference can be configured using the 8KPOL bit in the **TEST1** register. For 2kHz and 4kHz clocks, the LOCK8K bit is ignored and direct-lock mode is used.

7.4.2.3 DIVN Mode

In DIVN mode, the internal divider is configured from the value stored in the **DIVN** registers. The DIVN value must be chosen so that when the selected reference is divided by DIVN+1 the output clock is 8kHz. The DPLLs lock to the 8kHz output of the divider. DIVN mode can only be used for input clocks whose frequency is an integer multiple of 8 kHz and less than or equal to 155.52MHz. The DIVN register field can range from 1 to 19,439 inclusive. The same DIVN+1 factor is used for all input clocks configured for DIVN mode. When DIVN = 1 in an **ICR** register, the **FREQ** field of that register is ignored. Note that although DIVN divider is able to divide down clock rates has as high as 155.52MHz (DIVN = 19,439), the CMOS/TTL inputs are only rated for a maximum clock rate of 125MHz (DIVN = 15,624).

7.5 Input Clock Quality Monitoring

Each input clock is continuously monitored for frequency accuracy and activity. Frequency monitoring is described in Section 7.5.1, while activity monitoring is described in Sections 7.5.2 and 7.5.3. Any input clock that has a frequency out-of-band alarm or activity alarm is automatically declared invalid. The valid/invalid state of each input clock is reported in the corresponding real-time status bit in register VALSR1 or VALSR2. When the valid/invalid state of a clock changes, the corresponding latched status bit is set in register MSR1 or MSR2, and an interrupt request occurs if the corresponding interrupt enable bit is set in registers IER1 or IER2. Input clocks marked invalid cannot be selected as the reference for either DPLL. If the T4 DPLL does not have any valid input clocks available, the T4NOIN status bit is set to 1 in MSR3.

7.5.1 Frequency Monitoring

The DS3100 monitors the frequency of each input clock and invalidates any clock whose frequency is outside of specified limits. Two frequency limits can be specified: a soft limit and a hard limit. For all input clocks except the T0 DPLL's selected reference, these limits are specified in the ILIMIT register. For the T0 DPLL's selected reference the limits are specified in the SRLIMIT register. When the frequency of an input clock is greater than or equal to the soft limit, the corresponding SOFT alarm bit is set to 1 in the ISR registers. The soft limit is only for monitoring; triggering it does not invalidate the clock. When the frequency of an input clock is greater than or equal to the hard limit, the corresponding HARD alarm bit is set to 1 in the ISR registers, and the clock is marked invalid in the VALSR registers. Monitoring according to the hard and soft limits is enabled/disabled using the HARDEN and SOFTEN bits in the MCR10 register. Both the ILIMIT and SRLIMIT registers have a default soft limit of $\pm 11.43\text{ppm}$ and a default hard limit of $\pm 15.24\text{ppm}$. Limits can be set from $\pm 3.81\text{ppm}$ to $\pm 60.96\text{ppm}$ in 3.81ppm steps. Both the SOFT and HARD alarm limits have hysteresis as required by GR-1244. Frequency monitoring is only done on an input clock when the clock does not have an activity alarm.

Frequency measurement can be done with respect to the internal 204.8MHz master clock or the 77.76MHz T0 DPLL output, as specified by the FMONCLK bit in MCR10. Measured frequency can be read from any frequency monitor by specifying the input clock in the FMEASIN field of MCR11 and reading the frequency from the FMEAS register.

7.5.2 Activity Monitoring

Each input clock is monitored for activity and proper behavior using a leaky bucket accumulator. A leaky bucket accumulator is similar to an analog integrator: the output amplitude increases in the presence of input events and gradually decays in the absence of events. When events occur infrequently, the accumulator value decays fully between events and no alarm is declared. When events occur close enough together, the accumulator increments faster than it can decay and eventually reaches the alarm threshold. After an alarm has been declared, if events occur infrequently enough, the accumulator can decay faster than it is incremented and eventually reaches the alarm clear threshold.

The leaky bucket accumulator for each input clock can be assigned one of four configurations (0 through 3) in the BUCKET field of the ICR registers. Each leaky bucket configuration has programmable size, alarm declare threshold, alarm clear threshold, and decay rate, all of which are specified in the LBxY registers at addresses 50h through 5Fh.

Activity monitoring is divided into 128ms intervals. The accumulator is incremented once for each 128ms interval in which the input clock is inactive for more than two cycles (more than four cycles for 155.52MHz input clocks). Thus the "fill" rate of the bucket is at most 1 unit per 128ms, or approximately 8 units/second. During each period of 1, 2, 4 or 8 intervals (programmable), the accumulator decrements if no irregularities occur. Thus the "leak" rate of the bucket is approximately 8, 4, 2, or 1 units/second. A leak is prevented when a fill event occurs in the same interval.

When the value of an accumulator reaches the alarm threshold (LBxU register), the corresponding ACT alarm bit is set to 1 in the ISR registers, and the clock is marked invalid in the VALSR registers. When the value of an accumulator reaches the alarm clear threshold (LBxL register), the activity alarm is cleared by clearing the clock's ACT bit. The accumulator cannot increment past the size of the bucket specified in the LBxS register. The decay rate of the accumulator is specified in the LBxD register. The values stored in the leaky bucket configuration registers must have the following relationship at all times: $\text{LBxS} \geq \text{LBxU} > \text{LBxL}$.

When the leaky bucket is empty, the minimum time to declare an activity alarm in seconds is $LBxU / 8$ (where the “x” in “LbxU” is the leaky bucket configuration number, 0 to 3). The minimum time to clear an activity alarm in seconds is $[2^{LBxD} \times (LBxS - LBxL) / 8]$. For example, assume $LBxU = 8$, $LBxL = 1$, $LBxS = 10$, and $LBxD = 0$. The minimum time to declare an activity alarm would be $8 / 8 = 1$ second. The minimum time to clear the activity alarm would be $[2^0 \times (10 - 1) / 8 = 1.125$ seconds].

For an input clock that is connected to a BITS receiver, if $BCCR5:BPV = 1$ then the accumulator is also incremented whenever a BPV is detected in the incoming signal. See Section 7.10.2 for details. For input clocks IC1 and IC2 configured in composite clock mode, if $MCR5:BITERR = 1$, then the accumulator is also incremented whenever a violation of the one-BPV-in-eight pattern is detected.

7.5.3 Selected Reference Activity Monitoring

The input clock that each DPLL is currently locked to is called the selected reference. The quality of a DPLL’s selected reference is exceedingly important, since missing cycles and other anomalies on the selected reference can cause unwanted jitter, wander or frequency offset on the output clocks. When anomalies occur on the selected reference they must be detected as soon as possible to give the DPLL opportunity to temporarily disconnect from the reference until the reference is available again. By design, the regular input clock activity monitor (Section 7.5.2) is too slow to be suitable for monitoring the selected reference. Instead, each DPLL has its own fast activity monitor that detects inactivity within approximately two missing reference clock cycles (within approximately four missing cycles for 155.52MHz references).

When the T0 DPLL detects a no-activity event, it immediately enters mini-holdover mode to isolate itself from the selected reference and sets the SRFAIL bit in $MSR2$. The setting of the SRFAIL bit can cause an interrupt request on the INTREQ pin if the corresponding enable bit is set in $IER2$. If $MCR10:SRFPIN = 1$, the SRFAIL output pin follows the state of the SRFAIL status bit. Optionally, a no-activity event can also cause an ultra-fast reference switch (see Section 7.6.4). When $PHLIM1:NALOL = 0$ (default), the T0 DPLL does not declare loss-of-lock during no-activity events. If the selected reference becomes available again before any alarms are declared by the activity monitor or frequency monitor, then the T0 DPLL continues to track the selected reference using nearest-edge locking ($\pm 180^\circ$) to avoid cycle slips. When $NALOL = 1$, the T0 DPLL declares loss-of-lock during no-activity events. This causes the T0 state machine to transition to the loss-of-lock state, which sets the $MSR2:STATE$ bit and causes an interrupt request if enabled. If the selected reference becomes available again before any alarms are declared by the activity monitor or frequency monitor, then the T0 DPLL tracks the selected reference using phase/frequency locking ($\pm 360^\circ$) until phase lock is reestablished.

When the T4 DPLL detects a no-activity event, its behavior is similar to the T0 DPLL with respect to the $PHLIM1:NALOL$ control bit. Unlike the T0 DPLL, however, the T4 DPLL does not set the SRFAIL status bit. If $NALOL = 1$, the T4 DPLL clears the $OPSTATE:T4LOCK$ status bit, which sets $MSR3:T4LOCK$ and causes an interrupt request if enabled.

7.5.4 Composite Clock Inputs

When input clocks IC1 and IC2 are configured for composite clock mode ($MCR5:IC1SF = 0$ and $MCR5:IC2SF = 0$), they are also monitored for various defects (AMI error, LOS, etc.) See Section 7.11.1 for further details.

7.6 Input Clock Priority, Selection, and Switching

7.6.1 Priority Configuration

During normal operation, the selected reference for the T0 DPLL and the selected reference for the T4 DPLL are chosen automatically based on the priority rankings assigned to the input clocks in the input priority registers (IPR1 to IPR7). Each of these seven registers has priority fields for two input clocks. When T4T0 = 0 in the MCR11 register, the IPR registers specify the input clock priorities for the T0 DPLL. When T4T0 = 1, the IPR registers specify the input clock priorities for the T4 DPLL. The default input clock priorities, for both PLLs, are shown in Table 7-4.

Any unused input clock should be given the priority value 0, which disables the clock and marks it as unavailable for selection. Priority 1 is highest while priority 15 is lowest. The same priority can be given to two or more clocks.

Table 7-4. Default Input Clock Priorities

INPUT CLOCK	DEFAULT PRIORITY	INPUT CLOCK	DEFAULT PRIORITY
IC1	2	IC8	9
IC2	3	IC9	10
IC3	4	IC10	11
IC4	5	IC11	12 or 1 ⁽¹⁾
IC5	6	IC12	13
IC6	7	IC13	14
IC7	8	IC14	15

Note 1: During reset, the default priority for IC11 is set to 12 in the master device and set to 1 in the slave device. Devices are configured as master and slave by the value of the MASTSLV pin. (The state of the MASTSLV pin is mirrored in the MASTSLV bit of the MCR3 register.) See Section 7.9.

7.6.2 Automatic Selection Algorithm

The real-time valid/invalid state of each input clock is maintained in the VALSR1 and VALSR2 registers. The selected reference can be marked invalid for phase, frequency or activity. Other input clocks can be invalidated for frequency or activity.

The reference selection algorithm for each DPLL chooses the highest-priority valid input clock to be the selected reference. To select the proper input clock based on these criteria, the selection algorithm maintains a priority table of valid inputs. The top three entries in this table and the selected reference are displayed in the PTAB1 and PTAB2 registers. When T4T0 = 0 in the MCR11 register, these registers indicate the highest priority input clocks for the T0 DPLL. When T4T0 = 1, they indicate the highest priority input clocks for the T4 path.

If two or more input clocks are given the same priority number then those inputs are prioritized among themselves using a fixed circular list. If one equal-priority clock is the selected reference but becomes invalid then the next equal-priority clock in the list becomes the selected reference. If an equal-priority clock that is not the selected reference becomes invalid, it is simply skipped over in the circular list. The selection among equal-priority inputs is inherently nonrevertive, and revertive switching mode (see next paragraph) has no effect in the case where multiple equal-priority inputs have the highest priority.

An important input to the selection algorithm for T0 DPLL is the REVERT bit in the MCR3 register. In revertive mode (REVERT = 1), if an input clock with a higher priority than the selected reference becomes valid, the higher-priority reference immediately becomes the selected reference. In nonrevertive mode (REVERT = 0), the higher-priority reference does not immediately become the selected reference but does become the highest-priority reference in the priority table (REF1 field in the PTAB1 register). (The selection algorithm always switches to the highest-priority valid input when the selected reference goes invalid, regardless of the state of the REVERT bit.) For many applications, nonrevertive mode is preferred for the T0 DPLL because it minimizes disturbances on the output clocks due to reference switching. The T4 DPLL always operates in revertive mode.

In nonrevertive mode, planned switchover to a newly valid higher priority input clock can be done manually under software control. The validation of the new higher priority clock sets the corresponding status bit in the MSR1 or

MSR2 register, which can drive an interrupt request on the INTREQ pin if needed. System software can then respond to this change of state by briefly enabling revertive mode (toggling REVERT high then back low) to drive the switchover to the higher priority clock.

In most systems redundant timing cards are required, with one functioning as the master and the other as the slave. In such systems the priority tables of the master and slave must match. The DS3100's register set makes it easy for the slave's priority table to track the master's table. At system start-up, the same priorities must be assigned to the input clocks, for both DPLLs, in the master and slave devices. During operation, if an input clock becomes valid or invalid in one device (master or slave), the change is flagged in that device's **MSR1** or **MSR2** register, which can drive an interrupt request on the INTREQ pin if needed. The real-time valid/invalid state of the input clocks can then be read from that device's **VALSR1** and **VALSR2** registers. Once the nature of the state change is understood, the control bits of the other device's **VALCR1** and **VALCR2** registers can be manipulated to mark clocks invalid in the other device as well.

7.6.3 Forced Selection

The T0FORCE field in the **MCR2** register and the T4FORCE field in the **MCR4** register provide a way to force a specified input clock to be the selected reference for the T0 and T4 DPLLs, respectively. In both T0FORCE and T4FORCE, values of 0 and 15 specify normal operation with automatic reference selection. Values from 1 to 14 specify the input clock to be the forced selection. Internally forcing is accomplished by giving the specified clock the highest priority (as specified in **PTAB1:REF1**). In revertive mode (**MCR3:REVERT** = 1) the forced clock automatically becomes the selected reference (as specified in **PTAB1:SELREF**) as well. In nonrevertive mode (T0 DPLL only) the forced clock only becomes the selected reference when the existing selected reference is invalidated or made unavailable for selection. In both revertive and nonrevertive modes when an input is forced to be the highest priority, the normal highest priority input (when no input is forced) is listed as the second-highest priority (**PTAB2:REF2**) and the normal second-highest priority input is listed as the third-highest priority (**PTAB2:REF3**).

7.6.4 Ultra-Fast Reference Switching

By default, disqualification of the selected reference and switchover to another reference occurs when the activity monitor's inactivity alarm threshold has been crossed, a process that takes on the order of hundreds of milliseconds or seconds. For the T0 DPLL, an option for extremely fast disqualification and switchover is also available. When ultra-fast switching is enabled (**MCR10:UFSW** = 1), if the fast activity monitor detects approximately two missing clock cycles it declares the reference failed by forcing the leaky bucket accumulator to its upper threshold (see Section 7.5.2) and initiates reference switching. This is in addition to setting the SRFAIL bit in **MSR2** and optionally generating an interrupt request, as described in Section 7.5.3. When ultra-fast switching occurs, the T0 DPLL transitions to the prelocked 2 state, which allows switching to occur faster by bypassing the Loss-of-Lock state. The device should be in non-revertive mode when ultra-fast switching is enabled. If the device is in revertive mode, ultra-fast switching could cause excessive reference switching when the highest priority input is intermittent.

7.6.5 External Reference Switching Mode

In the external reference switching mode, the SRC5W input pin controls reference switching between two clock inputs. This mode is enabled by setting the EXT5W bit to 1 in the **MCR10** register. In this mode, if the SRC5W pin is high, the device is forced to lock to input IC3 (if the priority of IC3 is nonzero in **IPR2**) or IC5 (if the priority of IC3 is zero) whether or not the selected input has a valid reference signal. If the SRC5W pin is low the device is forced to lock to input IC4 (if the priority of IC4 is non-zero in **IPR2**) or IC6 (if the priority of IC4 is zero) whether or not the selected input has a valid reference signal. During reset the default value of the EXT5W bit is latched from the SRC5W pin. If external reference switching mode is enabled during reset, the default frequency tolerance (**DLIMIT** registers) is configured to ± 80 ppm rather than the normal default of ± 9.2 ppm.

In external reference switching mode the device is simply a clock switch, and the DPLL is forced to lock onto the selected reference whether it is valid or not. Unlike forced reference selection (Section 7.6.3) this mode controls the **PTAB1:SELREF** field directly and is therefore not affected by the state of the **MCR3:REVERT** bit. During external reference switching mode, only **PTAB1:SELREF** is affected; the REF1, REF2 and REF3 fields in the **PTAB** registers continue to indicate the highest, second-highest, and third-highest priority valid inputs chosen by the automatic selection logic. External reference switching mode only affects the T0 DPLL.

7.6.6 Output Clock Phase Continuity During Reference Switching

If phase build out is enabled ($PBOEN = 1$ in [MCR10](#)) or the DPLL frequency limit ([DLIMIT](#)) is set to less than ± 30 ppm then the device always complies with the GR-1244-CORE requirement that the rate of phase change must be less than 81ns per 1.326ms during reference switching.

7.7 DPLL Architecture and Configuration

Both the T0 and T4 paths of the device are digital PLLs (DPLLs) with analog PLLs (APLLs) at the output stage. This architecture combines the benefits of both PLL types.

Digital PLLs have two key benefits: (1) stable, repeatable performance that is insensitive to process variations, temperature and voltage, and (2) flexible behavior that is easily programmed via configuration registers. DPLLs use digital frequency synthesis (DFS) to generate various clocks. In DFS, a high-speed master clock (204.8MHz) is multiplied up from the 12.800MHz local oscillator clock applied to the REFCLK pin. This master clock is then digitally divided down to the desired output frequency. Since the resolution of the DFS process is one master clock cycle or 4.88ns, the DFS output clock has jitter of up to 1 master clock UI (4.88ns) pk-pk.

The analog PLLs filter the jitter from the DPLLs, reducing the 4.88ns pk-pk jitter to 0.5ns pk-pk and 60ps RMS, typical, measured broadband (10Hz to 1GHz).

The DPLLs in the device are configurable for many PLL parameters including bandwidth, damping factor, input frequency, pull-in/hold-in range, loop frequency, output frequency, input-to-output phase offset, phase build-out, and more. No knowledge of loop equations or gain parameters is required to configure and operate the device. No external components are required for the DPLLs or the APLLs except the high-quality local oscillator connected to the REFCLK pin.

The T0 path is the main path through the device, and the T0 DPLL has a full free-run/locked/holdover state machine and full programmability. The T4 path is a simpler frequency converter/synthesis path, lacking the low bandwidth settings, phase build-out, phase adjustment controls, and holdover state found in the T0 DPLL.

7.7.1 T0 DPLL State Machine

The T0 DPLL has three main timing modes: locked, holdover, and free-run. The control state machine for the T0 DPLL has states for each timing mode as well as three temporary states: prelocked, prelocked 2, and loss-of-lock. The state transition diagram is shown in [Figure 7-1](#). Descriptions of each state are given in the paragraphs below. During normal operation the state machine controls state transitions. When necessary, however, the state can be forced using the T0STATE field of the [MCR1](#) register.

Whenever the T0 DPLL changes state, the STATE bit in [MSR2](#) is set, which can cause an interrupt request if enabled. The current T0 DPLL state can be read from the T0STATE field of the [OPSTATE](#) register.

7.7.1.1 Free-Run State

Free-run mode is the reset default state. In free-run, all output clocks are derived from the 12.800MHz local oscillator attached to the REFCLK pin. The frequency of each output clock is a specific multiple of the local oscillator. The frequency accuracy of each output clock is equal to the frequency accuracy of the master clock (see [Section 7.3](#)). The state machine transitions from free-run to the prelocked state when at least one input clock is valid.

7.7.1.2 Prelocked State

The prelocked state provides a 100-second period (default value of [PHLKTO](#) register) for the DPLL to lock to the selected reference. If phase lock is achieved during this period then the state machine transitions to locked mode.

If the DPLL fails to lock to the selected reference within the phase-lock time-out period specified by [PHLKTO](#) then a phase lock alarm is raised (corresponding LOCK bit set in the [ISR](#) register), invalidating the input (ICn bit goes low in [VALSR](#) registers). If another input clock is valid then the state machine re-enters the prelocked state and tries to lock to the alternate input clock. If no other input clocks are valid then the state machine transitions back to the free-run state.

In revertive mode ($REVERT = 1$ in [MCR3](#)), if a higher priority input clock becomes valid during the phase-lock timeout period, then the state machine re-enters the prelocked state and tries to lock the higher priority input. If a

phase-lock timeout period longer than 100 seconds is required for locking (such as 700 seconds for Stratum 3E or 1000 seconds for Stratum 2 applications), the [PHLKTO](#) register must be configured accordingly.

Figure 7-1. T0 DPLL State Transition Diagram

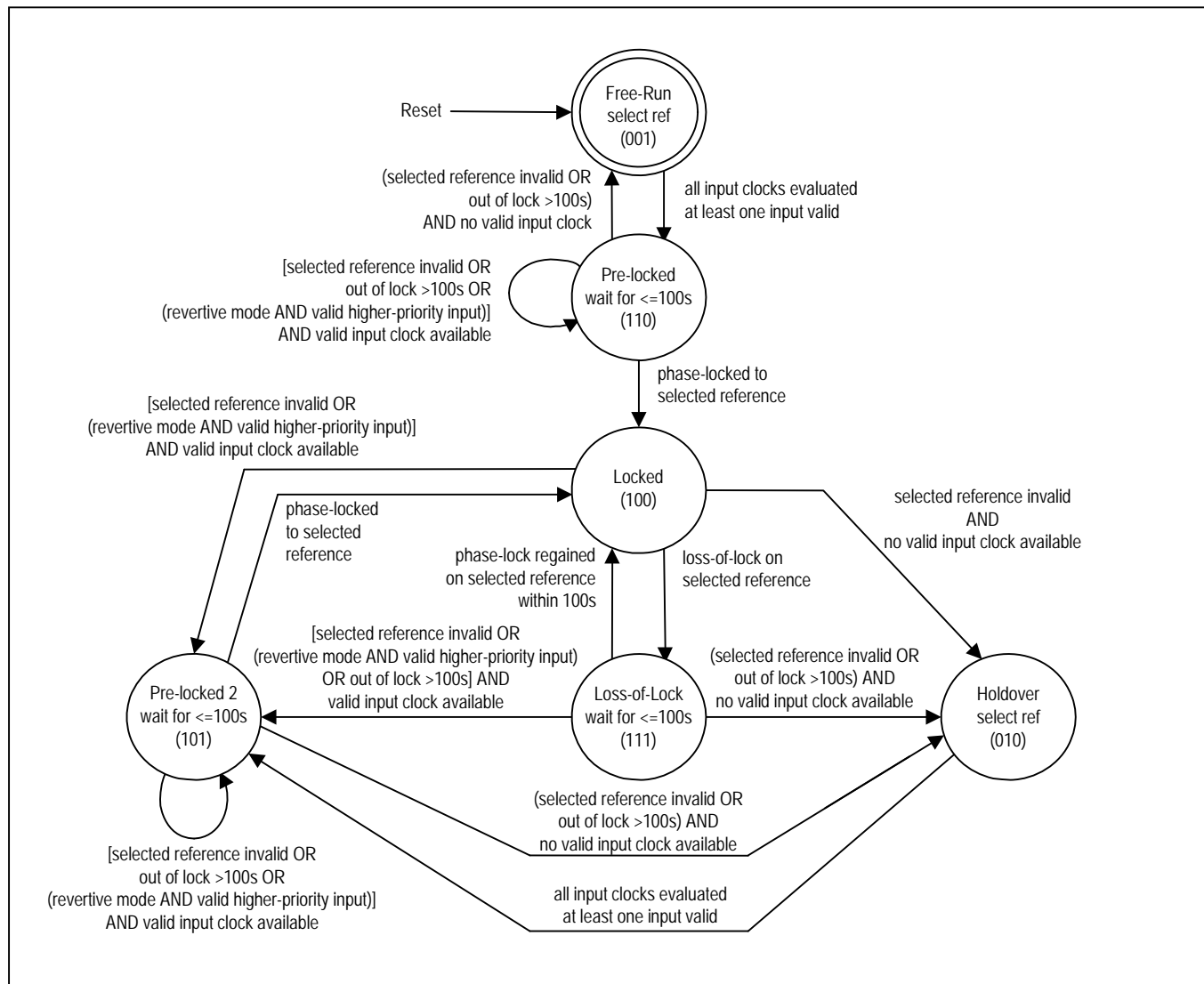

- Note 1:** An input clock is valid when it has no activity alarm, no hard frequency limit alarm, and no phase lock alarm (see the [VALSR](#) registers and the [ISR](#) registers).
- Note 2:** All input clocks are continuously monitored for activity and frequency.
- Note 3:** Only the selected reference is monitored for loss of lock.
- Note 4:** Phase lock is declared internally when the DPLL has maintained phase lock continuously for approximately 1 to 2 seconds.
- Note 5:** To simplify the diagram, the phase-lock timeout period is always shown as 100s, which is the default value of the [PHLKTO](#) register. Longer or shorter timeout periods can be specified as needed by writing the appropriate value to the [PHLKTO](#) register.

7.7.1.3 Locked State

The T0 DPLL state machine can reach the locked state from the prelocked, prelocked 2, or loss-of-lock states when the DPLL has locked to the selected reference for at least one second (see Section 7.7.6). In the locked state, the output clocks track the phase and frequency of the selected reference.

While in the locked state, if the selected reference is so impaired that an activity alarm or a hard frequency limit alarm is raised (corresponding ACT or HARD bit set in the **ISR** register), then the selected reference is invalidated (ICn bit goes low in **VALSR** registers), and the state machine immediately transitions to either the prelocked 2 state (if another valid input clock is available) or the holdover state (if no other input clock is valid).

If loss-of-lock is declared while in the locked state, the state machine transitions to the loss-of-lock state.

7.7.1.4 Loss-of-Lock State

When the loss-of-lock detectors (see Section 7.7.6) indicate loss-of-phase lock, the state machine immediately transitions from the locked state to the loss-of-lock state. In the loss-of-lock state the DPLL tries for 100 seconds (default value of **PHLKTO** register) to regain phase lock. If phase lock is regained during that period, the state machine transitions back to the locked state.

If, during the phase-lock timeout period specified by **PHLKTO**, the selected reference is so impaired that an activity alarm or a hard frequency limit alarm is raised (corresponding ACT or HARD bit set in the **ISR** registers), then the selected reference is invalidated (ICn bit goes low in **VALSR** registers), and the state machine immediately transitions to either the prelocked 2 state (if another valid input clock is available) or the holdover state (if no other input clock is valid).

If phase lock cannot be regained by the end of the phase-lock timeout period, then a phase lock alarm is raised (corresponding LOCK bit set in the **ISR** registers), the selected reference is invalidated (ICn bit goes low in **VALSR** registers), and the state machine transitions to either the prelocked 2 state (if another valid input clock is available) or the holdover state (if no other input clock is valid).

7.7.1.5 Prelocked 2 State

The prelocked and prelocked 2 states are similar. The prelocked 2 state provides a 100-second period (default value of **PHLKTO** register) for the DPLL to lock to the new selected reference. If phase lock is achieved during this period, then the state machine transitions to locked mode.

If the DPLL fails to lock to the new selected reference within the phase-lock timeout period specified by **PHLKTO**, then a phase lock alarm is raised (corresponding LOCK bit set in the **ISR** registers), invalidating the input (ICn bit goes low in **VALSR** registers). If another input clock is valid, the state machine re-enters the prelocked 2 state and tries to lock to the alternate input clock. If no other input clocks are valid, the state machine transitions to the holdover state.

In revertive mode (REVERT = 1 in **MCR3**), if a higher priority input clock becomes valid during the phase-lock timeout period, the state machine re-enters the prelocked 2 state and tries to lock to the higher priority input.

If a phase-lock timeout period longer than 100 seconds is required for locking (such as 700 seconds for Stratum 3E or 1000 seconds for Stratum 2 applications), then the **PHLKTO** register must be configured accordingly.

7.7.1.6 Holdover State

The device reaches the holdover state when it declares its selected reference invalid and has no other valid input clocks available. During holdover the T0 DPLL is not phase locked to any input clock but instead generates its output frequency from stored frequency information, typically the averaged frequency of the DPLL when it was in the locked state. The device can be configured for manual or automatic holdover as described in the following subsections. When at least one input clock has been declared valid the state machine immediately transitions from holdover to the prelocked 2 state and tries to lock to the highest priority valid clock.

7.7.1.6.1 Automatic Holdover

For automatic holdover (MANHO = 0 in **MCR3**), the device can be further configured for instantaneous mode or averaged mode. In *instantaneous mode* (AVG = 0 in **HOCR3**), the holdover frequency is set to the DPLL's current frequency at the moment of entry into holdover (i.e., the value of the FREQ field in the **FREQ1**, **FREQ2** and **FREQ3** registers when **MCR11:T4T0** = 0). The FREQ field is the DPLL's integral path and therefore is an average

frequency with a rate of change inversely proportional to the DPLL bandwidth. The DPLL's proportional path is not used to minimize the effect of recent phase disturbances on the holdover frequency.

In *averaged mode* (AVG = 1 in [HOCR3](#)), the holdover frequency is set to an internally averaged value. During locked operation the frequency indicated in the `FREQ` field is internally averaged. The `FAST` bit in [HOCR3](#) determines the period of this averaging. When `FAST=1` the frequency is averaged for a period of approximately 8 minutes. When `FAST = 0` (slow), the frequency is averaged for a period of approximately 110 minutes. The `T0 DPLL` indicates that it has acquired valid holdover values by setting the `FHORDY` and `SHORDY` status bits in [VALSR2](#) (real-time status) and [MSR4](#) (latched status). If `FAST = 0` and the `T0 DPLL` must enter holdover before the 110-minute average is available, then the 8-minute average is used, if available. Otherwise the instantaneous value from the integral path is used. If `FAST = 1` and the `T0 DPLL` must enter holdover before the 8-minute average is available, then the instantaneous value is used.

7.7.1.6.2 Manual Holdover

For *manual holdover* (`MANHO = 1` in [MCR3](#)), the holdover frequency is set by the `HOFREQ` field in the [HOCR1](#), [HOCR2](#) and [HOCR3](#) registers. The `HOFREQ` field has the same size and format as the current frequency field (`FREQ[18:0]` in the [FREQ1](#), [FREQ2](#), and [FREQ3](#) registers). If desired, software can, during locked operation, read the current frequency from `FREQ`, filter or average it over time, and then write the resulting holdover frequency to `HOFREQ`. The `FREQ` field is derived from the DPLL's integral path, and thus can be considered an average frequency with a rate of change inversely proportional to the DPLL bandwidth.

To combine internal averaging with additional software filtering, the `HOFREQ` field can be configured to read out the internally averaged frequency when `RDAVG = 1` in the [HOCR3](#) register. This averaged value can be read from `HOFREQ` regardless of the current holdover mode. The `FAST` bit in [HOCR3](#) specifies whether the value read is from the fast averager or the slow averager.

7.7.1.7 Mini-Holdover

When the selected reference fails, the fast activity monitor (Section [7.5.3](#)) isolates the `T0 DPLL` from the reference within one or two clock cycles to avoid adverse effects on the DPLL frequency. When this fast isolation occurs, the DPLL enters mini-holdover mode, with a mini-holdover frequency as specified by the `MINIHO` field of [HOCR3](#). Mini-holdover lasts until the selected reference returns or a new input clock has been chosen as the selected reference or the state machine enters the holdover state. Note that when the `T0 DPLL` is configured for manual holdover ([MCR3:MANHO=1](#)), mini-holdover is also configured for manual holdover and [HOCR3:MINIHO](#) is ignored.

7.7.2 T4 DPLL State Machine

The `T4 DPLL` has a simpler state machine than the `T0 DPLL`, as shown in [Figure 7-2](#). The `T4 DPLL` states are similar to the equivalent states of the `T0 DPLL`. Note that the `T4 DPLL` only operates in revertive switching mode.

Figure 7-2. T4 DPLL State Transition Diagram

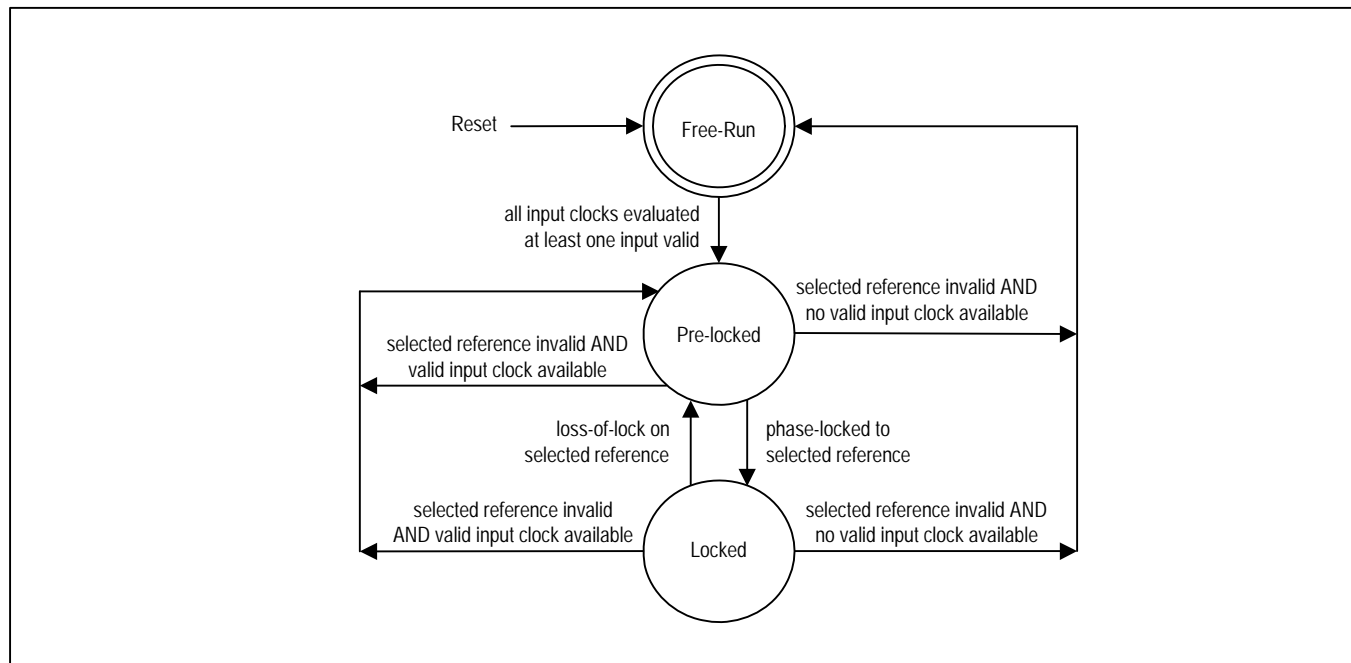

7.7.3 Bandwidth

The bandwidth of the T4 DPLL is configured in the **T4BW** register to be 18Hz, 35Hz, or 70Hz. This bandwidth value is used for both acquisition and locked mode.

The bandwidth of the T0 DPLL is configured in the **T0ABW** and **T0LBW** registers for various values from 0.5mHz to 70Hz. The **AUTOBW** bit in the **MCR9** register controls automatic bandwidth selection. When **AUTOBW** = 1, the T0 DPLL uses the **T0ABW** bandwidth during acquisition (not phase locked) and the **T0LBW** bandwidth when phase locked. When **AUTOBW** = 0 the T0 DPLL uses the **T0LBW** bandwidth all the time, both during acquisition and when phase locked.

When **LIMINT** = 1 in the **MCR9** register, the DPLL's integral path is limited (i.e., frozen) when the DPLL reaches minimum or maximum frequency. Setting **LIMINT** = 1 minimizes overshoot when the DPLL is pulling in.

7.7.4 Damping Factor

The damping factor for the T0 DPLL is configured in the DAMP field of the **T0CR2** register, while the damping factor the T4 DPLL is configured in the DAMP field of the **T4CR2** register. The reset default damping factors for both DPLLs are chosen to give a maximum wander gain peak of approximately 0.1dB. Available settings are a function of DPLL bandwidth (configured in the **T4BW**, **T0ABW**, and **T0LBW** registers). See [Table 7-5](#).

Table 7-5. Damping Factors and Peak Jitter/Wander Gain

BANDWIDTH	DAMP[2:0] VALUE	DAMPING FACTOR	GAIN PEAK (dB)
0.5mHz to 4Hz	1, 2, 3, 4, 5	5	0.1
8Hz	1	2.5	0.2
	2, 3, 4, 5	5	0.1
18 Hz	1	1.2	0.4
	2	2.5	0.2
	3, 4, 5	5	0.1
35 Hz	1	1.2	0.4
	2	2.5	0.2
	3	5	0.1
	4, 5	10	0.06
70 Hz	1	1.2	0.4
	2	2.5	0.2
	3	5	0.1
	4	10	0.06
	5	20	0.03

7.7.5 Phase Detectors

Phase detectors are used to compare a PLL's feedback clock with its input clock. Several phase detectors are available in both the T0 and T4 DPLLs:

- Phase/frequency detector (PFD)
- Early/late phase detector (PD2) for fine resolution
- Multicycle phase detector (MCPD) for large input jitter tolerance

These detectors can be used in combination to give fine phase resolution combined with large jitter tolerance. As with the rest of the DPLL logic, the phase detectors operate at input frequencies up to 77.76MHz. The multicycle phase detector detects and remembers phase differences of many cycles (up to 8191UI).

The phase detectors can be configured for normal phase/frequency locking ($\pm 360^\circ$ capture) or nearest-edge phase locking ($\pm 180^\circ$ capture). With nearest-edge detection the phase detectors are immune to occasional missing clock cycles. The DPLL automatically switches to nearest-edge locking when the multi-cycle phase detector is disabled and the other phase detectors determine that phase lock has been achieved. Setting **D180 = 1** in the **TEST1** register disables nearest-edge locking and forces the DPLL to use phase/frequency locking.

The early/late phase detector, also known as phase detector 2, is enabled and configured in the PD2* fields of registers **T0CR2** and **T0CR3** for the T0 DPLL and registers **T4CR2** and **T4CR3** for the T4 DPLL. The reset default settings of these registers are appropriate for all operating modes. Adjustments only affect small signal overshoot and bandwidth.

The multicycle phase detector is enabled by setting **MCPDEN=1** in the **PHLIM2** register. The range of the MCPD—from $\pm 1\text{UI}$ up to $\pm 8191\text{UI}$ —is configured in the **COARSELIM** field of **PHLIM2**. The MCPD tracks phase position over many clock cycles, giving high jitter tolerance. Thus the use of the MCPD is an alternative to the use of **LOCK8K** mode for jitter tolerance.

When **USEMCPD = 1** in **PHLIM2**, the MCPD is used in the DPLL loop, giving faster pull-in but more overshoot. In this mode the loop has similar behavior to **LOCK8K** mode. In both cases large phase differences contribute to the dynamics of the loop. When enabled by **MCPDEN = 1**, the MCPD tracks the phase position whether or not it is used in the DPLL loop.

7.7.6 Loss of Phase Lock Detection

Loss of phase lock is triggered by any of the following in both the T0 and T4 DPLLs:

- The fine phase lock detector (measures phase between input and feedback clocks)
- The coarse phase lock detector (measures whole cycle slips)
- Hard frequency limit detector
- Inactivity detector

The fine phase lock detector is enabled by setting FLEN = 1 in the [PHLIM1](#) register. The fine phase limit is configured in the FINELIM field of [PHLIM1](#).

The coarse phase lock detector is enabled by setting CLEN = 1 in the [PHLIM2](#) register. The coarse phase limit is configured in the COARSELIM field of [PHLIM2](#). This coarse phase lock detector is part of the multi-cycle phase detector (MCPD) described in Section 7.7.5. the COARSELIM fields sets both the MCPD range and the coarse phase limit, since the two are equivalent. If loss of phase lock should not be declared for multiple-UI input jitter then the fine phase lock detector should be disabled and the coarse phase lock detector should be used instead.

The hard frequency limit detector is enabled by setting FLLOL = 1 in the [DLIMIT3](#) register. The hard limit for the T0 DPLL is configured in registers [DLIMIT1](#) and [DLIMIT2](#). The T4 DPLL hard limit is fixed at ± 80 ppm. When the DPLL frequency reaches the hard limit, loss-of-lock is declared. The [DLIMIT3](#) register also has the SOFTLIM field to specify a soft frequency limit. Exceeding the soft frequency limit does not cause loss-of-lock to be declared. When the T0 DPLL frequency exceeds the soft limit the T0SOFT status bit is set in the [OPSTATE](#) register. When the T4 DPLL frequency exceeds the soft limit the T4SOFT status bit is set in [OPSTATE](#). Both the SOFT and HARD alarm limits have hysteresis as required by GR-1244.

The inactivity detector is enabled by setting NALOL = 1 in the [PHLIM1](#) register. When this detector is enabled the DPLL declares loss-of-lock after one or two missing clock cycles on the selected reference. See Section 7.5.3.

When the T0 DPLL declares loss of phase lock, the state machine immediately transitions to the loss-of-lock state, which sets the STATE bit in the [MSR2](#) register and requests an interrupt if enabled.

When the T4 DPLL declares loss of phase lock, the T4LOCK bit is cleared in the [OPSTATE](#) register, which sets the T4LOCK bit in the [MSR3](#) register and requests an interrupt if enabled.

7.7.7 Phase Monitor and Phase Build-Out

7.7.7.1 Phase Monitor

The T0 DPLL has a phase monitor that measures the phase error between the input clock reference and the DPLL output. The phase monitor is enabled by setting `PHMON:PMEN = 1`. When the T0 DPLL is set for low bandwidth, a phase transient on the input causes an immediate phase error that is gradually reduced as the DPLL tracks the input. When the measured phase error exceeds the limit set in the `PHMON:PMLIM` field, the phase monitor declares a phase monitor alarm by setting the `MSR3:PHMON` bit. The PMLIM field can be configured for a limit ranging from about 1 μ s to about 3.5 μ s.

7.7.7.2 Phase Build-Out in Response to Input Phase Transients

See Telcordia GR-1244-CORE Section 5.7 for an explanation of phase build-out (PBO) and the requirement for Stratum 2 and 3E clocks to perform PBO in response to input phase transients.

When the phase monitor is enabled (as described in Section 7.7.7.1) and `PHMON:PMPBEN = 1`, the T0 DPLL automatically triggers PBO events in response to input transients greater than the limit set in `PHMON:PMLIM`. The range of limits available in the PMLIM field allows the T0 DPLL to be configured to build out input transients greater than 3.5 μ s, greater than 1 μ s, or any threshold in between.

To determine when to perform PBO, the phase monitor watches for phase changes greater than 100ns in a 10ms interval on the selected reference. When such a phase change occurs, an internal 0.1 second timer is started. If during this interval the phase change is greater than the PMLIM threshold then a PBO event occurs. During a PBO event the device enters a temporary holdover state in which the phase difference between the selected reference and the output is measured and fed into the DPLL loop to absorb the input transient. After a PBO event, regardless of the input phase transient, the output phase transient is less than or equal to 5ns. Phase build-out can be frozen at the current phase offset by setting `MCR10:PBOFRZ = 1`. When PBO is frozen the T0 DPLL ignores subsequent phase build-out events and maintains the current phase offset between input and outputs.

7.7.7.3 Phase Build-Out in Response to Reference Switching

When `MCR10:PBOEN = 0`, phase build-out is not performed during reference switching, and the T0 DPLL always locks to the selected reference at zero degrees of phase. With PBO disabled, transitions from a failed reference to the next highest priority reference and transitions from holdover or free-run to locked mode cause phase transients on output clocks as the T0 DPLL jumps from its previous phase to the phase of the new selected reference.

When `MCR10:PBOEN = 1`, phase build-out is performed during reference switching. With PBO enabled, if the selected reference fails and another valid reference is available then the device enters a temporary holdover state in which the phase difference between the new reference and the output is measured and fed into the DPLL loop to absorb the input phase difference. Similarly, during transitions from holdover or free-run to locked mode, the phase difference between the new reference and the output is measured and fed into the DPLL loop to absorb the input phase difference. After a PBO event, regardless of the input phase difference, the output phase transient is less than or equal to 5ns.

Any time that PBO is enabled it can also be frozen at the current phase offset by setting `MCR10:PBOFRZ = 1`. When PBO is frozen the T0 DPLL ignores subsequent phase build-out events and maintains the current phase offset between inputs and outputs.

Disabling PBO while the T0 DPLL is in the locked state causes a phase change on the output clocks while the DPLL switches to tracking the selected reference with 0 degrees of phase error. The rate of phase change on the output clocks depends on the DPLL bandwidth. Enabling PBO in the locked state also causes a PBO event.

7.7.7.4 Manual Phase Build-Out Control

Software can have manual control over phase build-out, if required. Initial configuration for manual PBO involves locking to an input clock with frequency $\geq 6.48\text{MHz}$, setting `MCR10:PBOEN = 0` and `PHMON:PMPBEN = 0` to disable automatic phase build-out, and setting `PHMON:PMEN = 1` and the proper phase limit in `PHMON:PMLIM` to enable monitoring for a phase transient.

During operation, software can monitor for either a phase transient (`MSR3:PHMON = 1`) or a T0 DPLL state change (`MSR2:STATE = 1`). When either event occurs, software can perform the following procedure to execute a manual phase build-out (PBO) event:

- 1) Read the phase offset from the `PHASE` registers to decide whether or not to initiate a PBO event.
- 2) If a PBO event is desired then save the phase offset and set `MCR10:PBOEN` to cause a PBO event.
- 3) When the PBO event is complete (wait for a timeout and/or `PHASE = 0`), write the manual phase offset registers (`OFFSET`) with the phase offset read earlier. (**Note:** the `PHASE` register is in degrees, the `OFFSET` register is in picoseconds)
- 4) Clear `MCR10:PBOEN` and wait for the next event that may need a manual PBO.

7.7.7.5 PBO Phase Offset

An uncertainty of up to 5ns is introduced each time a phase build-out event occurs. This uncertainty results in a phase hit on the output. Over a large number of phase build-out events the mean error should be zero. The `PBOFF` register specifies a small fixed offset for each phase build-out event to skew the average error toward zero and eliminate accumulation of phase shifts in one direction.

7.7.8 Input to Output Phase Adjustment

When phase build-out is disabled (`PBOEN = 0` in `MCR10` and `PMPBEN = 0` in `PHMON`), the `OFFSET` registers can be used to adjust the phase of the T0 DPLL output clocks with respect to the selected reference. Output phase offset can be adjusted over a $\pm 200\text{ns}$ range in 6ps increments. This phase adjustment occurs in the feedback clock so that the output clocks are adjusted to compensate. The rate of change is therefore a function of DPLL bandwidth. To quickly track large changes in phase, either LOCK8K mode (Section 7.4.2.2) or the coarse phase detector (Section 7.7.5) should be used. Simply writing to the `OFFSET` registers with phase build-out disabled causes a change in the input to output phase which can be considered to be a delay adjustment.

7.7.9 Phase Recalibration

When a phase build-out occurs, either automatic or manual, the feedback frequency synthesizer does not get an internal alignment signal to keep it aligned with the output dividers, and therefore the phase difference between input and output may become incorrect. This could occur if there is a power supply glitch or EMI event that affects the sequential logic state machines. Setting the `FSCR3:RECAL` bit periodically causes a recalibration process to be executed, which corrects any phase error that may have occurred.

During the recalibration process the device puts the DPLL into mini holdover, internally ramps the phase offset to zero, resets all clock dividers, ramps the phase offset to the value stored in the `OFFSET` registers, and then switches the DPLL out of mini holdover. If the `OFFSET` registers are written during the recalibration process, the process will ramp the phase offset to the new offset value.

7.7.10 Frequency and Phase Measurement

Standard input clock frequency monitoring is described in Section 7.5.1. The input clock monitors report measured frequency with 3.8ppm resolution. More accurate measurement of frequency and phase can be accomplished using the DPLLs. The T0 DPLL is always monitoring its selected reference, but if the T4 DPLL is not otherwise used then it can be configured as a high-resolution frequency and phase monitor. Software can then connect the T4 DPLL to various input clocks on a rotating basis to measure frequency and phase. See `MCR4:T4FORCE`.

DPLL frequency measurements can be read from the `FREQ` field spanning registers `FREQ1`, `FREQ2` and `FREQ3`. This field indicates the frequency of the selected reference for either the T0 DPLL or the T4 DPLL, depending on the setting of the `T4T0` bit in `MCR11`. This frequency measurement has a resolution of 0.0003068ppm over a $\pm 80\text{ppm}$ range. The value read from the `FREQ` field is the DPLL's integral path value, which is an averaged measurement with an averaging time inversely proportional to DPLL bandwidth.

DPLL phase measurements can be read from the `PHASE` field spanning registers `PHASE1` and `PHASE2`. This field indicates the phase difference seen by the phase detector for either the T0 DPLL or the T4 DPLL, depending

on the setting of the T4T0 bit in [MCR11](#). This phase measurement has a resolution of approximately 0.7 degrees and is internally averaged with a -3dB attenuation point of approximately 100Hz. Thus, for low DPLL bandwidths the PHASE field gives input phase wander in the frequency band from the DPLL corner frequency up to 100Hz. This information could be used by software to compute a crude MTIE measurement up to an observation time of approximately 1000 seconds.

For the T0 DPLL, the PHASE field always indicates the phase difference between the selected reference and the internal feedback clock. The T4 DPLL, however, can be configured to measure the phase difference between two input clocks. When [T0CR1:T4MT0](#) = 1, the T4 path is disabled and the T4 phase detector is configured to compare the T0 DPLL selected reference with the T4 DPLL selected reference. Any input clock can then be forced to be the T4 DPLL selected reference using the T4FORCE field of [MCR4](#). This feature can be used, for example, to measure the phase difference between the T0 DPLL's selected reference and its next highest priority reference. Software could compute MTIE and TDEV with respect to the selected reference for any or all of the other input clocks.

When comparing the phase of the T0 and T4 selected references by setting [T0CR1:T4MT0](#) = 1, several details must be kept in mind. In this mode, the T4 path receives a copy of the T0 selected reference, either directly or through a divider to 8kHz. If the T4 selected reference is divided down to 8kHz using LOCK8K or DIVN modes (see Section 7.4.2), then the copy of the T0 selected reference is also divided down to 8kHz. If the T4 selected reference is configured for direct-lock mode, then the copy of the T0 selected reference is not divided down and must be the same frequency as the T4 selected reference. See [Table 7-6](#) for more details. (While [T0CR1:T4MT0](#) = 1 the T0 path continues to lock to the T0 selected reference in the manner specified in the corresponding [ICR](#) register.)

Table 7-6. T0 Adaptation for T4 Phase Measurement Mode

LOCKING MODE FOR T4 SELECTED REFERENCE	LOCKING MODE FOR T0 SELECTED REFERENCE	LOCKING MODE FOR COPY OF T0 SELECTED REF	FREQUENCY OF THE T4 SELECTED REF FOR T4/T0 PHASE MEASUREMENT	FREQUENCY OF THE T0 SELECTED REF FOR T4/T0 PHASE MEASUREMENT
DIVN or LOCK8K	DIRECT	LOCK8K	8kHz	8kHz
DIVN or LOCK8K	LOCK8K	LOCK8K	8kHz	8kHz
DIVN or LOCK8K	DIVN	DIVN	8kHz	8kHz
DIRECT	Any	DIRECT	Same as the T4 selected ref input frequency	Same as the T0 selected ref input frequency ⁽¹⁾

Note 1: In this case, the T0 select reference must be the same frequency as the T4 selected reference.

Note 2: If the T4 selected reference frequency is 8kHz and the T0 selected reference is a different frequency, the two references can be compared by configuring the T4 selected reference for 8 kHz and LOCK8K mode. This forces the copy of the T0 selected reference to be divided down to 8kHz using either LOCK8K or DIVN mode.

7.7.11 Input Wander and Jitter Tolerance

The device is compliant with the jitter and wander tolerance requirements of the standards listed in [Table 1-1](#). Wander is tolerated up to the point where wander causes an apparent long-term frequency offset larger than the limits specified in the [ILIMIT](#) and/or [SRLIMIT](#) registers. In such a situation the input clock would be declared invalid. Jitter is tolerated up to the point of eye closure. Either LOCK8K mode (see Section 7.4.2.2) or the multicycle phase detector (see Section 7.7.5) should be used for high jitter tolerance.

7.7.12 Jitter and Wander Transfer

In the DS3100, the transfer of jitter and wander from the selected reference to the output clocks has a programmable transfer function that is determined by the DPLL bandwidth. (See Section 7.7.3.) In the T0 DPLL, the 3dB corner frequency of the jitter transfer function can be set to any of 18 positions from 0.5mHz to 70Hz. In the T4 DPLL, the 3dB corner frequency of the jitter transfer function can be set to 18Hz, 35Hz, or 70Hz.

During locked mode, the transfer of wander from the local oscillator clock (connected to the REFCLK pin) to the output clocks is not significant as long as the DPLL bandwidth is set high enough to allow the DPLL to quickly compensate for oscillator frequency changes. During free-run and holdover modes, local oscillator wander has a much more significant effect. See Section 7.3.

7.7.13 Output Jitter and Wander

Several factors contribute to jitter and wander on the output clocks, including:

- Jitter and wander amplitude on the selected reference (while in the locked state)
- The jitter/wander transfer characteristic of the device (while in the locked state)
- The jitter and wander on the local oscillator clock signal (especially wander while in the holdover state)

The DPLL in the device has programmable bandwidth (see Section 7.7.3). With respect to jitter and wander, the DPLL behaves as a low-pass filter with a programmable pole. The bandwidth of the DPLL is normally set low enough to strongly attenuate jitter. The wander attenuation depends on the DPLL bandwidth chosen.

Over time frequency changes in the local oscillator can cause a phase difference between the selected reference and the output clocks. This is especially true at DPLL bandwidths of 0.1Hz and below because the DPLL's rate of change may be slower than the oscillator's rate of change. Oscillators with better stability will minimize this effect. In some applications an OCXO may be required rather than a TCXO. In the most demand applications, the OCXO may need to be shielded to further reduce the rate of temperature change and thus the rate of frequency change.

Typical MTIE and TDEV measurements for the DS3100 in locked mode are shown in Figure 7-3 and Figure 7-4, respectively.

Figure 7-3. Typical MTIE for T0 DPLL Output

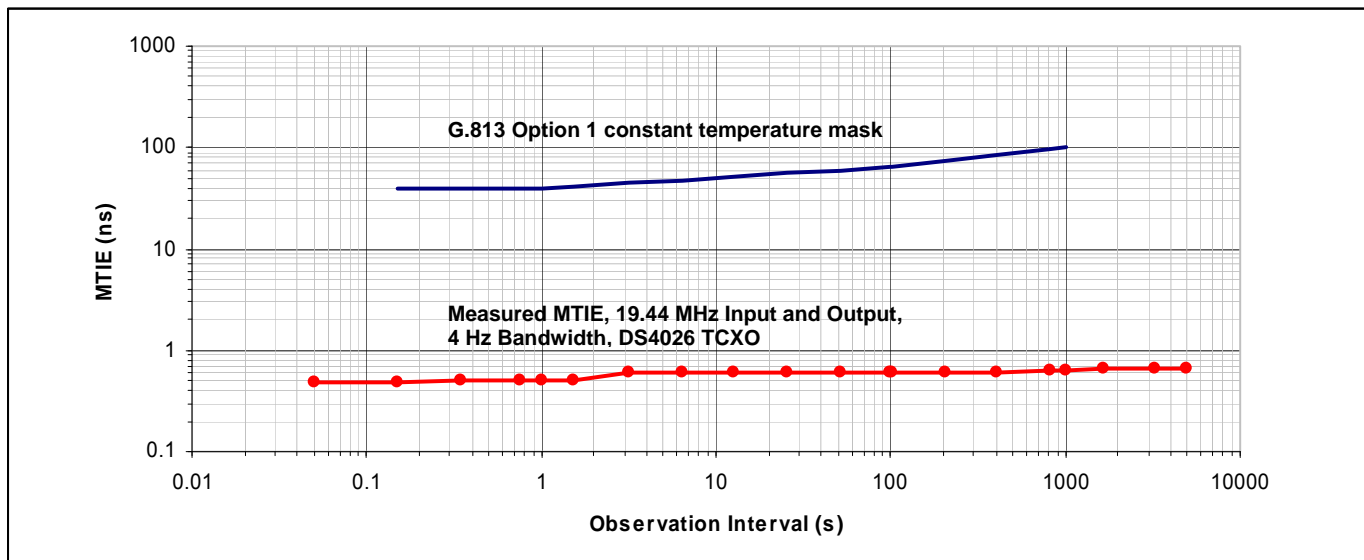
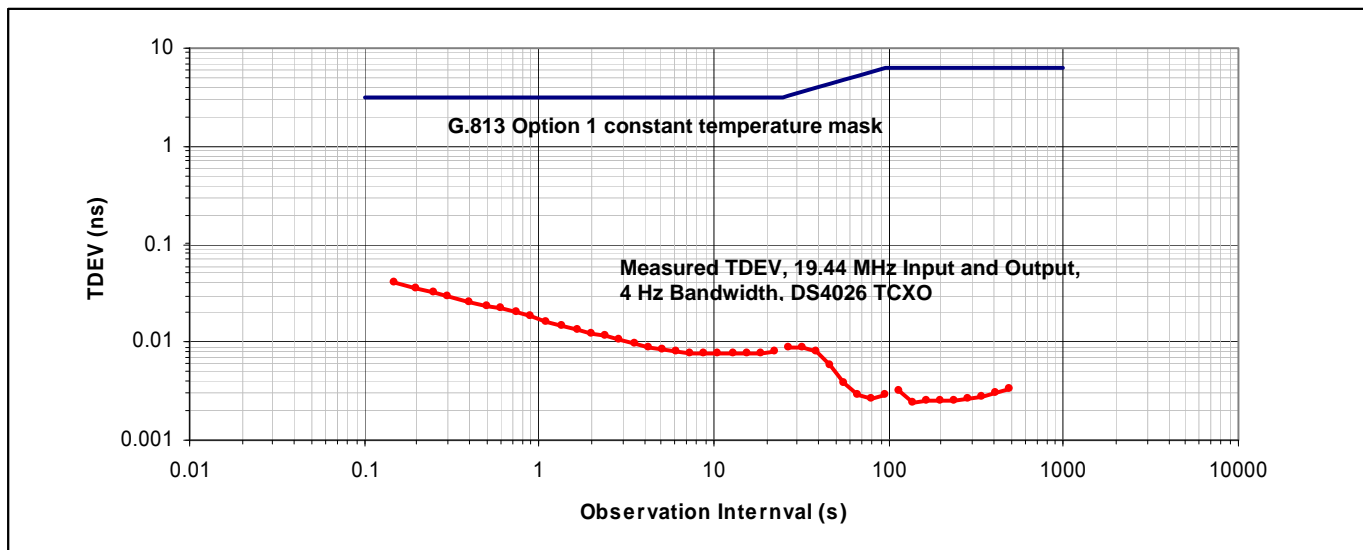

Figure 7-4. Typical TDEV for T0 DPLL Output



7.8 Output Clock Configuration

A total of 11 output clock pins, OC1 to OC11, are available on the device. Output clocks OC1 to OC7 are individually configurable for a variety of frequencies derived from either the T0 DPLL path or the T4 DPLL path. Output clocks OC8 to OC11 are more specialized, serving as a dedicated composite clock transmitter (OC8), a 1544/2.048kHz clock (OC9), an 8kHz frame sync (OC10), and a 2kHz multiframe sync (OC11). [Table 7-7](#) provides more detail on the capabilities of the output clocks.

Table 7-7. Output Clock Capabilities

OUTPUT CLOCK	SIGNAL FORMAT	FREQUENCIES SUPPORTED
OC1	CMOS/TTL	Frequency selection per Section 7.8.2.3 and Table 7-9 through Table 7-12
OC2	CMOS/TTL	
OC3	CMOS/TTL	
OC4	CMOS/TTL	
OC5	CMOS/TTL	
OC6	LVDS	
OC7	LVDS	
OC8	AMI	64kHz composite clock
OC9	CMOS/TTL	1.544MHz or 2.048MHz
OC10	CMOS/TTL	8kHz frame sync with programmable pulse width and polarity
OC11	CMOS/TTL	2kHz multiframe sync with programmable pulse width and polarity

7.8.1 Signal Format Configuration

Output clocks OC6 and OC7 are enabled and disabled via the OC6SF and OC7SF configuration bits in the **MCR8** register. The LVDS electrical specifications are listed in [Table 10-4](#), and the recommended LVDS termination is shown in [Figure 10-1](#). These outputs can be easily interfaced to LVPECL and CML inputs on neighboring ICs using a few external passive components. See [Maxim App Note HFAN-1.0](#) for details.

Output clock OC8 is a dedicated composite clock (CC) transmitter. The composite clock signal is a 64kHz AMI clock with an embedded 8kHz clock indicated by deliberate bipolar violations (BPVs) every 8 clock cycles. See [Section 7.11.2](#) for OC8 configuration details. The AMI CC electrical specifications are shown in [Table 10-6](#), and the recommended external components are shown in [Table 10-3](#).

Output clocks OC1 to OC5 and OC9 to OC11 are always CMOS/TTL signal format.

7.8.2 Frequency Configuration

The frequency of most of the output clocks is a function of the settings used to configure the components of the T0 and T4 PLL paths. These components are shown in the detailed block diagram of [Figure 7-5](#).

The T0 and T4 PLLs use digital frequency synthesis (DFS) to generate various clocks. In DFS, a high-speed master clock (204.8MHz) is divided down to the desired output frequency. The edges of the output clock, however, are not ideally located in time but rather are aligned with the edges of the master clock resulting in jitter with an amplitude equal to 1 period of the master clock (i.e., 4.88ns).

7.8.2.1 T0 DPLL and APLL Details

The 77M forward DFS block (see [Figure 7-5](#)) uses the 204.8MHz master clock and DFS to synthesize a 77.76MHz clock with 4.88ns inherent peak-to-peak jitter. This clock can be fed directly to the feedback DFS block or it can be passed through the feedback APLL to reduce jitter to less than 1ns. The 77M forward DFS block handles phase build-out and any phase offset configured in the **OFFSET** registers. Thus, the 77M output DFS block and the 77M forward DFS block are frequency locked but may have a phase offset.

The feedback DFS block takes as its input clock either the output from the 77M forward DFS or the jitter-filtered output from the T0 feedback APLL. The feedback DFS block synthesizes the appropriate locking frequency for use in the phase-frequency detector (PFD).

The 77M output DFS block also uses the 204.8MHz master clock and DFS to synthesize a 77.76MHz clock with 4.88ns peak-to-peak jitter. This clock goes to both the output APLL and the low frequency (LF) output DFS block.

Figure 7-5. DPLL Block Diagram

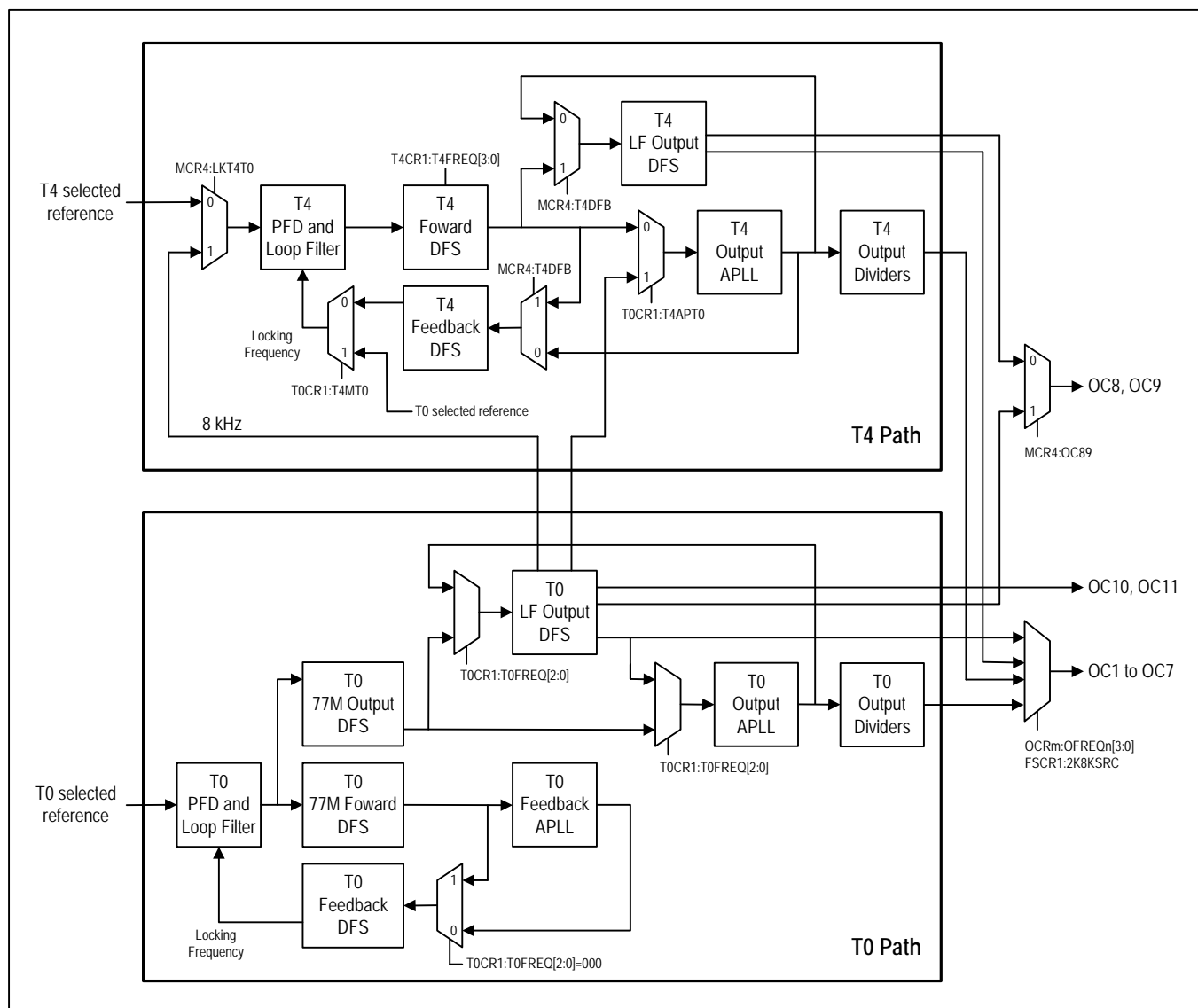

The LF output DFS block takes as its input clock either the output from the 77M output DFS or the jitter-filtered output of the output APLL. The LF output DFS block synthesizes three frequencies: Digital1, Digital2, and a third frequency for producing multiple $N \times DS1/E1$ rates via the output APLLs. When the output APLL uses the output from the LF output DFS, the LF output DFS uses the output from the 77M output DFS block to avoid a loop. The LF output DFS also synthesizes frequencies for use by output clocks OC8, OC9, OC10, and OC11.

The frequency of the Digital1 clock is configured by the DIG1SS bit in [MCR6](#) and the DIG1F[1:0] field in [MCR7](#). The frequency of the Digital2 clock is configured by the DIG2AF and DIG2SS bits in [MCR6](#) and the DIG2F[1:0] field in [MCR7](#). Digital1 and Digital2 can be independently configured for any of the frequencies shown in [Table 7-8](#). Because they are generated by DFS and cannot be filtered by an APLL, Digital1 and Digital2 have relatively high-amplitude jitter. The minimum jitter is approximately 12ns (one period of the input clock to the LF output DFS) when the T0 path is in analog feedback mode. The maximum jitter is approximately 17ns when T0 is in digital feedback mode. Both the Digital1 and Digital2 rates are available to output clocks OC1 to OC7.

The output APLL takes as its input clock either the output of the 77M output DFS or one of the frequencies from the LF output DFS (77.76MHz, $16 \times DS1$, $24 \times DS1$, $12 \times E1$, or $16 \times E1$). The output frequency of the output APLL is four times the input frequency (e.g., 311.04MHz for 77.76MHz input). The output clock is then divided by 1, 2, 4, 6, 8, 12, 16, and 48. These clock rates are available to the OC1 to OC7 output clocks.

Table 7-8. Digital1 and Digital2 Frequencies

DIGxF[1:0] SETTING IN MCR7	DIGxSS SETTING IN MCR6	FREQUENCY (MHz)
00	0	2.048
01	0	4.096
10	0	8.192
11	0	16.384
00	1	1.544
01	1	3.088
10	1	6.176
11	1	12.352

Note: When **MCR6:DIG2AF** = 1, Digital2 generates 6312kHz (must set **MCR6:DIG2SS** = 0 and **MCR7:DIG2F** = 00).

7.8.2.2 T4 DPLL and APLL Details

The T4 path is simpler than the T0 path and does not support phase build-out or phase offset. The T4 path can be locked to an input clock or to the T0 path (by setting **LKT4T0**=1 in **MCR4**). Using the 204.8MHz master clock and DFS, the T4 forward DFS block generates a clock with 4.88 ns inherent peak-to-peak jitter at any of the following frequencies: 16 x DS1, 24 x DS1, 12 x E1, 16 x E1, DS3, 2 x E3, 62.5MHz, or 77.76MHz. This clock can be fed directly to the T4 feedback DFS block (**T4DFB** = 1 in **MCR4**), or it can be passed through the T4 output APLL to reduce jitter to less than 1ns (**T4DFB** = 0).

The T4 feedback DFS block takes as its input clock either the output from the T4 forward DFS or the jitter-filtered output from the T4 output APLL, depending on the setting of **MCR4:T4DFB**. The T4 feedback DFS block synthesizes the appropriate locking frequency for use in the T4 phase-frequency detector (PFD).

The T4 output APLL filters jitter to less than 1 ns and takes as its input clock either the output of the T4 forward DFS block or one of the frequencies from the T0 LF output DFS (16xDS1, 24xDS1, 12xE1, 16xE1 or 4x6312kHz, as specified by **T0CR1:T0FT4[2:0]**). The output frequency of the output APLL is four times the input frequency (e.g., 311.04MHz for 77.76MHz input). The output clock is then divided by 2, 4, 8, 16, 48, and 64. These clock rates are available to the OC1 to OC7 output clocks.

The T4 LF output DFS block normally takes as its input clock the jitter-filtered output of the T4 output APLL. When the T4 output APLL is connected to the T0 LF output DFS (**T0CR1:T4APT0** = 1), the T4 output APLL must be disconnected from the T4 DPLL loop by configuring the loop for digital feedback (**MCR4:T4DFB** = 1). In this situation the T4 LF output DFS takes its input from the T4 forward DFS block. The T4 LF output DFS block generates 2kHz and 8kHz frequencies for use by output clocks OC1 to OC7 (when **FSCR1:2K8KSRC** = 1) and synthesizes frequencies for use by output clocks OC8 and OC9 (when **MCR4:OC89** = 1).

7.8.2.3 OC1 to OC7 Configuration

The following is a step-by-step procedure for configuring the frequencies of output clocks OC1 to OC7:

- 1) Determine whether the T4 path must be independent of the T0 path or not. If the T4 path must be independent, set T4APT0 = 0 in register **T0CR1**. If the T4 path can be locked to the T0 path then set T4APT0 = 1.
- 2) Use **Table 7-9** to select a set of output frequencies for each path, T0 and T4. Each path can only generate one set of output frequencies. (In SONET/SDH equipment the T0 path is typically configured for an APLL frequency of 311.04MHz in order to get 19.44MHz and/or 38.88MHz output clocks to distribute to system line cards.)
- 3) Determine from **Table 7-9** the T0 and T4 APLL frequencies required for the frequency sets chosen in step 2.
- 4) Configure the T0FREQ field in register **T0CR1** as shown in **Table 7-10** for the T0 APLL frequency determined in step 3. Configure the T4FREQ field in register **T4CR1** as shown in **Table 7-11** for the T4 APLL frequency determined in step 3. If the T4 APLL is locked to the T0 DPLL then the T0FT4 field in **T0CR1** must also be configured as shown in **Table 7-11**.
- 5) Using **Table 7-9** and **Table 7-12**, configure the frequencies of output clocks OC1 through OC7 in the OFREQn fields of registers **OCR1** to **OCR4**.
- 6) If any of OC1 to OC7 are configured for 2kHz or 8kHz frequency, set 2K8KSRC = 0 in **FSCR1** to source these frequencies from the T0 path or 2K8KSRC = 1 to source these frequencies from the T4 path.

Table 7-13 lists all possible frequencies for output clocks OC1 to OC7 and specifies how to configure the T0 path and/or the T4 path to obtain each frequency. **Table 7-13** also indicates the expected jitter amplitude for each frequency.

Table 7-9. APLL Frequency to Output Frequencies (T0 and T4)

APLL FREQUENCY	APLL/2	APLL/4	APLL/6	APLL/8	APLL/12	APLL/16	APLL/48	APLL/64
311.04	155.52	77.76	51.84	38.88	25.92	19.44	6.48	4.86
274.944	137.472	68.736	—	34.368	—	17.184	5.728	4.296
250.000	125.000	62.500	—	31.250	—	15.625	5.2083	3.90625
178.944	89.472	44.736	—	22.368	—	11.184	3.728	2.796
148.224	74.112	37.056	24.704	18.528	12.352	9.264	3.088	2.316
131.072	65.536	32.768	21.84533	16.384	10.92267	8.192	2.73067	2.048
100.992	50.496	25.248	16.832	12.624	8.416	6.312	2.104	1.578
98.816	49.408	24.704	16.46933	12.352	8.23467	6.176	2.05867	1.544
98.304	49.152	24.576	16.384	12.288	8.192	6.144	2.048	1.536

Note: All frequencies in MHz. Common telecom frequencies are in **bold** type.

Table 7-10. T0 APLL Frequency to T0 Path Configuration

T0 APLL FREQUENCY (MHz)	T0 FREQUENCY MODE	T0FREQ[2:0] SETTING IN T0CR1	OUTPUT JITTER (pk-pk, ns)
311.04	77.76MHz, digital feedback	000	< 0.5
311.04	77.7MHz, analog feedback	001	< 0.5
98.304	12 x E1 (digital feedback)	010	< 2
131.072	16 x E1 (digital feedback)	011	< 2
148.224	24 x DS1 (digital feedback)	100	< 2
98.816	16 x DS1 (digital feedback)	101	< 2
100.992	4 x 6312kHz (digital feedback)	110	< 2

Table 7-11. T4 APLL Frequency to T4 Path Configuration

T4 APLL FREQUENCY (MHz)	T4 FREQUENCY MODE	T4 FORWARD DFS FREQ (MHz)	T4APT0 SETTING IN T0CR1	T4FREQ[3:0] SETTING IN T4CR1	T0FT4[2:0] SETTING IN T0CR1	OUTPUT JITTER (pk-pk, ns)
311.04	Squelched	77.76	0	0000	XXX	< 0.5
311.04	Normal	77.76	0	0001	XXX	< 0.5
98.304	12 x E1	24.576	0	0010	XXX	< 0.5
131.072	16 x E1	32.768	0	0011	XXX	< 0.5
148.224	24 x DS1	37.056	0	0100	XXX	< 0.5
98.816	16 x DS1	24.704	0	0101	XXX	< 0.5
274.944	2 x E3	68.736	0	0110	XXX	< 0.5
178.944	DS3	44.736	0	0111	XXX	< 0.5
100.992	4 x 6312 kHz	25.248	0	1000	XXX	< 0.5
250.000	GbE ÷ 16	62.500	0	1001	XXX	< 0.5
98.304	T0 12 x E1	—	1	XXXX	000	< 2
131.072	T0 16 x E1	—	1	XXXX	010	< 2
148.224	T0 24 x DS1	—	1	XXXX	100	< 2
98.816	T0 16 x DS1	—	1	XXXX	110	< 2
100.992	4 x 6312kHz	—	1	XXXX	111	< 2

Table 7-12. OC1 to OC7 Output Frequency Selection

REGISTER VALUE ⁽¹⁾	FREQUENCY						
	OC1	OC2	OC3	OC4	OC5	OC6	OC7
0000	Disabled	Disabled	Disabled	Disabled	Disabled	Disabled	Disabled
0001	2kHz	2kHz	2kHz	2kHz	2kHz	2kHz	2kHz
0010	8kHz	8kHz	8kHz	8kHz	8kHz	8kHz	8kHz
0011	Digital2	Digital2	Digital2	Digital2	Digital2	T0 APLL/2	Digital2
0100	Digital1	Digital1	Digital1	Digital1	Digital1	Digital1	T0 APLL/2
0101	T0 APLL/48	T0 APLL/48	T0 APLL/48	T0 APLL/48	T0 APLL/48	T0 APLL/1	T0 APLL/48
0110	T0 APLL/16	T0 APLL/16	T0 APLL/16	T0 APLL/16	T0 APLL/16	T0 APLL/16	T0 APLL/16
0111	T0 APLL/12	T0 APLL/12	T0 APLL/12	T0 APLL/12	T0 APLL/12	T0 APLL/12	T0 APLL/12
1000	T0 APLL/8	T0 APLL/8	T0 APLL/8	T0 APLL/8	T0 APLL/8	T0 APLL/8	T0 APLL/8
1001	T0 APLL/6	T0 APLL/6	T0 APLL/6	T0 APLL/6	T0 APLL/6	T0 APLL/6	T0 APLL/6
1010	T0 APLL/4	T0 APLL/4	T0 APLL/4	T0 APLL/4	T0 APLL/4	T0 APLL/4	T0 APLL/4
1011	T4 APLL/64	T4 APLL/64	T4 APLL/64	T4 APLL/2	T4 APLL/2	T4 APLL/64	T4 APLL/64
1100	T4 APLL/48	T4 APLL/48	T4 APLL/48	T4 APLL/48	T4 APLL/48	T4 APLL/48	T4 APLL/48
1101	T4 APLL/16	T4 APLL/16	T4 APLL/16	T4 APLL/16	T4 APLL/16	T4 APLL/16	T4 APLL/16
1110	T4 APLL/8	T4 APLL/8	T4 APLL/8	T4 APLL/8	T4 APLL/8	T4 APLL/8	T4 APLL/8
1111	T4 APLL/4	T4 APLL/4	T4 APLL/4	T4 APLL/4	T4 APLL/4	T4 APLL/4	T4 APLL/4

Note 1: The value of the OFREQn field (in the OCR1 through OCR4 registers) corresponding to output clock OCn.

Table 7-13. Possible Frequencies for OC1 to OC7

FREQUENCY (MHz)	T0 DPLL MODE	T4 DPLL MODE	T4 APLL SOURCE	OFREQN SETTING	JITTER (TYP)	
					RMS (ps)	pk-pk (ns)
2kHz	77.76MHz, analog	—	—	0001	60	0.6
2kHz	Any digital feedback			0001	1400	5.0
8kHz	77.76MHz, analog			0010	60	0.6
8kHz	Any digital feedback			0010	1400	5.0
1.536 Not OC4 or OC5		12 x E1	T4 DPLL	1011	55	0.6
1.536 Not OC4 or OC5			T0 12 x E1	1011	250	1.5
1.544 Via Digital1, not OC7	77.76MHz, analog			0100	3800	13
1.544 Via Digital2, not OC6	77.76MHz, analog			0011	3800	13
1.544 Via Digital1, not OC7	Any digital feedback			0100	3800	18
1.544 Via Digital2, not OC6	Any digital feedback			0011	3800	18
1.544 Not OC4 or OC5		16 x DS1	T4 DPLL	1011	140	1.2
1.544 Not OC4 or OC5			T0 16 x DS1	1011	275	1.9
1.578 Not OC4 or OC5		4 x 6312kHz	T4 DPLL	1011	240	1.5
1.578 Not OC4 or OC5			T0 4x6312kHz	1011	260	1.8
2.048 Not OC6	12 x E1 mode			0101	425	2.6
2.048 Via Digital1, not OC7	77.76MHz, analog			0100	3800	13
2.048 Via Digital2, not OC6	77.76MHz, analog			0011	3800	13
2.048 Via Digital1, not OC7	Any digital feedback			0100	3800	18
2.048 Via Digital2, not OC6	Any digital feedback			0011	3800	18
2.048		12 x E1	T4 DPLL	1100	55	0.6
2.048			T0 12 x E1	1100	250	1.5
2.048 Not OC4 or OC5		16 x E1	T4 DPLL	1011	50	0.5
2.048 Not OC4 or OC5			T0 16 x E1	1011	350	2.4
2.059 Not OC6	16 x DS1			0101	435	2.8
2.059		16 x DS1	T4 DPLL	1100	140	1.2
2.059			T0 16 x DS1	1100	275	1.9
2.104 Not OC6	4 x 6312 kHz			0101	340	2.3
2.104		4 x 6312kHz	T4 DPLL	1100	240	1.8
2.104			T0 4x6312kHz	1100	260	1.8
2.316 Not OC4 or OC5		24 x DS1	T4 DPLL	1011	150	1.0
2.316 Not OC4 or OC5			T0 24 x DS1	1011	400	2.8
2.731 Not OC6	16 x E1			0101	380	2.6
2.731		16 x E1	T4 DPLL	1100	50	0.5
2.731			T0 16 x E1	1100	350	2.4

FREQUENCY (MHz)	T0 DPLL MODE	T4 DPLL MODE	T4 APLL SOURCE	OFREQN SETTING	JITTER (TYP)	
					RMS (ps)	pk-pk (ns)
2.796 Not OC4 or OC5		DS3	T4 DPLL	1011	80	0.7
3.088 Not OC6	24 x DS1			0101	400	2.8
3.088 Via Digital1, not OC7	77.76MHz, analog			0100	3800	13
3.088 Via Digital2, not OC6	77.76MHz, analog			0011	3800	13
3.088 Via Digital1, not OC7	Any digital feedback			0100	3800	18
3.088 Via Digital2, not OC6	Any digital feedback			0011	3800	18
3.088		24 x DS1	T4 DPLL	1100	150	1.0
3.088			T0 24 x DS1	1100	400	2.8
3.728		DS3	T4 DPLL	1100	80	0.7
3.90625 Not OC4 or OC5		GbE ÷ 16	T4 DPLL	1011	70	0.6
4.096 Via Digital1, not OC7	77.76 MHz, analog			0100	3800	13
4.096 Via Digital2, not OC6	77.76 MHz, analog			0011	3800	13
4.096 Via Digital1, not OC7	Any digital feedback			0100	3800	18
4.096 Via Digital2, not OC6	Any digital feedback			0011	3800	18
4.296 Not OC4 or OC5		2 x E3	T4 DPLL	1011	350	2.0
4.86 Not OC4 or OC5		77.76MHz	T4 DPLL	1011	60	0.6
5.2083		GbE ÷ 16	T4 DPLL	1100	70	0.6
5.728		2 x E3	T4 DPLL	1100	350	2.0
6.144	12 x E1			0110	425	2.6
6.144		12 x E1	T4 DPLL	1101	55	0.6
6.144			T0 12 x E1	1101	250	1.5
6.176	16 x DS1			0110	435	2.8
6.176 Via Digital1, not OC7	77.76MHz, analog			0100	3800	13
6.176 Via Digital2, not OC6	77.76MHz, analog			0011	3800	13
6.176 Via Digital1, not OC7	Any digital feedback			0100	3800	18
6.176 Via Digital2, not OC6	Any digital feedback			0011	3800	18
6.176		16 x DS1	T4 DPLL	1101	140	1.2
6.176			T0 16 x DS1	1101	275	1.9
6.312	4 x 6312kHz			0110	340	2.3
6.312 Via Digital 2, not OC6	77.76MHz, analog			0011	3800	13
6.312 Via Digital 2, not OC6	Any digital feedback			0011	3800	18
6.312		4 x 6312kHz	T4 DPLL	1101	240	1.8
6.312			T0 4 x 6312kHz	1101	260	1.8
6.48 Not OC6	77.76MHz, analog			0101	60	0.6
6.48 Not OC6	77.76MHz, digital			0101	60	0.6
6.48		77.76 MHz	T4 DPLL	1100	60	0.6
8.192	12 x E1			0111	425	2.6
8.192	16 x E1			0110	380	2.6
8.192 Via Digital1, not OC7	77.76 MHz, analog			0100	3800	13
8.192 Via Digital2, not OC6	77.76 MHz, analog			0011	3800	13
8.192 Via Digital1, not OC7	Any digital feedback			0100	3800	18
8.192 Via Digital2, not OC6	Any digital feedback			0011	3800	18
8.192		16 x E1	T4 DPLL	1101	50	0.5
8.192			T0 16 x E1	1101	350	2.4
8.235	16 x DS1			0111	435	2.8
8.416	4 x 6312kHz			0111	340	2.3
9.264	24 x DS1			0110	400	2.8
9.264		24 x DS1	T4 DPLL	1101	150	1.0
9.264			T0 24 x DS1	1101	400	2.8
10.923	16 x E1			0111	380	2.6
11.184		DS3	T4 DPLL	1101	80	0.7
12.288	12 x E1			1000	425	2.6
12.288		12 x E1	T4 DPLL	1110	55	0.6
12.288			T0 12 x E1	1110	250	1.5
12.352	24 x DS1			0111	400	2.8
12.352	16 x DS1			1000	435	2.8
12.352		16 x DS1	T4 DPLL	1110	140	1.2
12.352			T0 16 x DS1	1110	275	1.9
12.352 Via Digital1, Not OC7	77.76MHz, analog			0100	3800	13

FREQUENCY (MHz)	T0 DPLL MODE	T4 DPLL MODE	T4 APLL SOURCE	OFREQN SETTING	JITTER (TYP)		
					RMS (ps)	pk-pk (ns)	
12.352	Via Digital2, Not OC6	77.76MHz, analog		0011	3800	13	
12.352	Via Digital1, Not OC7	Any digital feedback		0100	3800	18	
12.352	Via Digital2, Not OC6	Any digital feedback		0011	3800	18	
12.624		4 x 6312kHz		1000	340	2.3	
12.624		4 x 6312kHz	T4 DPLL	1110	240	1.8	
12.624			T0 4x6312kHz	1110	260	1.8	
15.625		GbE ÷ 16	T4 DPLL	1101	70	0.6	
16.384	12 x E1			1001	425	2.6	
16.384	16 x E1			1000	380	2.6	
16.384		16 x E1	T4 DPLL	1110	50	0.5	
16.384			T0 16 x DS1	1110	275	1.9	
16.384	Via Digital1, Not OC7	77.76MHz, analog		0100	3800	13	
16.384	Via Digital2, Not OC6	77.76MHz, analog		0011	3800	13	
16.384	Via Digital1, Not OC7	Any digital feedback		0100	3800	18	
16.384	Via Digital2, Not OC6	Any digital feedback		0011	3800	18	
16.469		16 x DS1		1001	435	2.8	
16.832		4 x 6312kHz		1001	340	2.3	
17.184		2 x E3	T4 DPLL	1101	350	2.0	
18.528		24 x DS1		1000	400	2.8	
18.528		24 x DS1	T4 DPLL	1110	150	1.0	
18.528			T0 24 x DS1	1110	400	2.8	
19.44		77.76MHz, analog		0110	60	0.6	
19.44		77.76MHz, digital		0110	60	0.6	
19.44		77.76 MHz	T4 DPLL	1101	60	0.6	
21.845		16 x E1		1001	380	2.6	
22.368		DS3	T4 DPLL	1110	80	0.7	
24.576		12 x E1		1010	425	2.6	
24.576		12 x E1	T4 DPLL	1111	55	0.6	
24.576			T0 12 x E1	1111	250	1.5	
24.704		24 x DS1		1001	400	2.8	
24.704		16 x DS1		1010	435	2.8	
24.704		16 x DS1	T4 DPLL	1111	140	1.2	
24.704			T0 16 x DS1	1111	275	1.9	
25.000		GbE ÷ 16	T4 DPLL	1100	70	0.6	
25.248		4 x 6312kHz		1010	340	2.3	
25.248		4 x 6312kHz	T4 DPLL	1111	240	1.8	
25.248			T0 4x6312kHz	1111	260	1.8	
25.92		77.76MHz, analog		0111	60	0.6	
25.92		77.76MHz, digital		0111	60	0.6	
31.25		GbE ÷ 16	T4 DPLL	1110	70	0.6	
32.768		16 x E1		1010	380	2.6	
32.768		16 x E1	T4 DPLL	1111	50	0.5	
32.768			T0 16 x E1	1111	350	2.4	
34.368		2 x E3	T4 DPLL	1110	350	2.0	
37.056		24 x DS1		1010	400	2.8	
37.056		24 x DS1	T4 DPLL	1111	150	1.0	
37.056			T0 24 x DS1	1111	400	2.8	
38.88		77.76MHz, analog		1000	60	0.6	
38.88		77.76MHz, digital		1000	60	0.6	
38.88		77.76MHz	T4 DPLL	1110	60	0.6	
44.736		DS3	T4 DPLL	1111	80	0.7	
49.152	OC6 and OC7 Only	12 x E1		0011/0100	425	2.6	
49.152	OC4 and OC5 Only		12 x E1	T4 DPLL	1011	55	0.6
49.152	OC4 and OC5 Only		T0 12 x E1	1011	250	1.5	
49.408	OC6 and OC7 Only	16 x DS1		0011/0100	435	2.8	
49.408	OC4 and OC5 Only		16 x DS1	T4 DPLL	1011	140	1.2
49.408	OC4 and OC5 Only		T0 16 x DS1	1011	275	1.9	
50.496	OC6 and OC7 Only	4 x 6312kHz		0011/0100	340	2.3	
50.496	OC4 and OC5 Only	4 x 6312kHz	T4 DPLL	1011	240	1.8	

FREQUENCY (MHz)	T0 DPLL MODE	T4 DPLL MODE	T4 APLL SOURCE	OFREQN SETTING	JITTER (TYP)		
					RMS (ps)	pk-pk (ns)	
50.496	OC4 and OC5 Only		T0 4 x 6312kHz	1011	260	1.8	
51.84		77.76MHz, analog		1001	60	0.6	
51.84		77.76MHz, digital		1001	60	0.6	
62.50		GbE ÷ 16	T4 DPLL	1111	70	0.6	
65.536	OC6 and OC7 Only	16 x E1		0011/0100	380	2.6	
65.536	OC4 and OC5 Only		16 x E1	1011	50	0.5	
65.536	OC4 and OC5 Only		T0 16 x E1	1011	350	2.4	
68.736			2 x E3	1111	350	2.0	
74.112	OC6 and OC7 Only	24 x DS1		0011/0100	400	2.8	
74.112	OC4 and OC5 Only		24 x DS1	1011	150	1.0	
74.112	OC4 and OC5 Only		T0 24 x DS1	1011	400	2.8	
77.76		77.76MHz, analog		1010	60	0.6	
77.76		77.76MHz, digital		1010	60	0.6	
77.76			77.76MHz	1111	60	0.6	
89.472	OC4 and OC5 Only		DS3	T4 DPLL	1011	80	0.7
98.304	OC6 Only	12 x E1		0101	425	2.6	
98.816	OC6 Only	16 x DS1		0101	435	2.8	
100.992	OC6 Only	4 x 6312kHz		0101	340	2.3	
125.000	OC5 Only		GbE ÷ 16	T4 DPLL	1011	70	0.6
131.072	OC6 Only	16 x E1		0101	380	2.6	
137.472	OC4 and OC5 Only		2 x E3	T4 DPLL	1011	350	2.0
148.224	OC6 Only	24 x DS1		0101	400	2.8	
155.52	OC6 and OC7 Only	77.76MHz, analog		0011/0100	60	0.6	
155.52	OC6 and OC7 Only	77.76MHz, digital		0011/0100	60	0.6	
155.52	OC4 and OC5 Only		77.76MHz	T4 DPLL	1011	60	0.6
311.04	OC6 Only	77.76MHz, analog		0101	60	0.6	
311.04	OC6 Only	77.76MHz, digital		0101	60	0.6	

7.8.2.4 OC8 and OC9 Configuration

Output clocks OC8 and OC9 are generated by digital frequency synthesis (DFS) from either the T0 path or the T4 path, depending on the setting of the OC89 bit in [MCR4](#). When generated from the T4 path (OC89 = 0), if ASQUEL = 1 in [T4CR1](#) then OC8 and OC9 are automatically squelched when T4 has no valid input references.

OC8 is always a 64kHz composite clock transmitter and therefore does not require any frequency configuration. Being 64kHz, OC8 can be divided down directly from the source DFS block's input clock. The jitter on OC8 can range from 13ns to 17ns, depending on whether the DPLL is in analog or digital feedback mode. See Section [7.11.2](#) for additional OC8 configuration details.

OC9 is always a DS1 or E1 clock. OC9 is enabled by setting OC9EN = 1 in the [OCR4](#) register, and it is configured for DS1 or E1 with the OC9SON bit in [T4CR1](#) (when OC89 = 0) or with the SONSDH bit in [MCR3](#) (when OC89 = 1). OC9 must be synthesized, rather than directly divided down, from the source DFS block's input clock. The jitter on OC9 is therefore a function of the jitter on the input clock and the jitter generated during synthesis. OC9 jitter can range from 11ns to 20ns.

7.8.2.5 OC10 and OC11 Configuration

Output clocks OC10 and OC11 are always generated from the T0 path. OC10 is enabled by setting OC10EN = 1 in the [OCR4](#) register, while OC11 is enabled by setting OC11EN = 1 in [OCR4](#).

When 8KPUL = 0 in [FSCR1](#), OC10 is configured as an 8kHz clock with 50% duty cycle. When 8KPUL = 1, OC10 is an 8kHz frame sync that pulses low once every 125µs with pulse width equal to one cycle of output clock OC3. When 8KINV = 1 in [FSCR1](#), the clock or pulse polarity of OC10 is inverted.

When 2KPUL = 0 in [FSCR1](#), OC11 is configured as a 2kHz clock with 50% duty cycle. When 2KPUL = 1, OC11 is a 2kHz frame sync that pulses low once every 500µs with pulse width equal to one cycle of output clock OC3. When 2KINV = 1 in [FSCR1](#), the clock or pulse polarity of OC11 is inverted.

If either 8KPUL = 1 or 2KPUL = 1, then output clock OC3 must be generated from the T0 DPLL and must be configured for a frequency of 1.544MHz or higher or the OC10/OC11 pulses may not be generated correctly. Figure 7-6 shows how the 8KPUL and 8KINV control bits affect the OC10 output. The 2KPUL and 2KINV bits have an identical effect on OC11.

Figure 7-6. OC10 8kHz Options

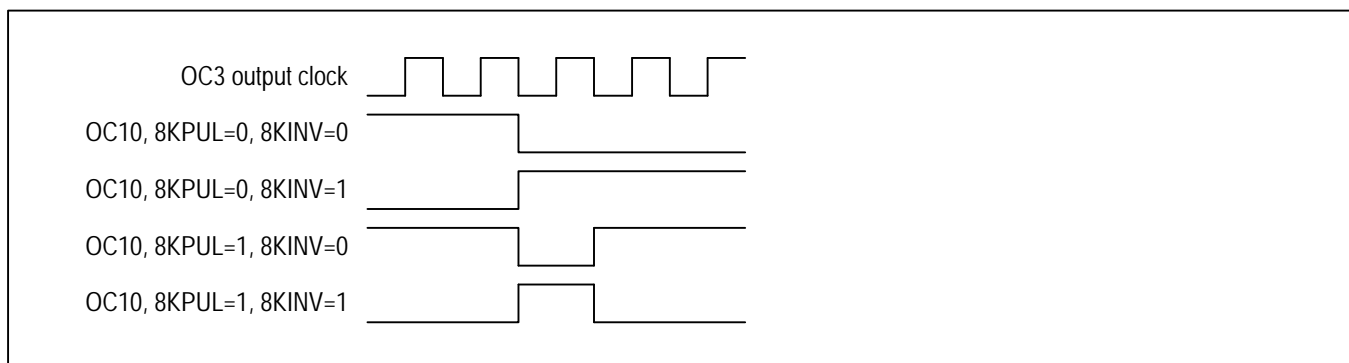

7.9 Equipment Redundancy Configuration

Most high-reliability SONET/SDH systems require two identical timing cards for equipment redundancy. The DS3100 directly supports this requirement. In such a system one timing card is designated the master while the other is designated the slave. The rest of the system, outside the timing cards, is set up to take timing from the master normally, but to automatically switch to taking timing from the slave if the master fails. To avoid excessive phase transients when switching between master timing and slave timing, the clocks from the master and the slave must be frequency locked and usually phase locked as well. To accomplish this requires a method involving both static configuration and ongoing oversight by system software. The elements of this methodology are listed in Table 7-14.

Table 7-14. Equipment Redundancy Methodology

1.	The various clock sources available in the system should be wired to the same pins on the slave as on the master, except: A. One output clock from the master device should be wired to an input clock on the slave. B. One output clock from the slave device should be wired to an input clock on the master.
2.	The input clock priorities (IPR registers) on master and slave should be identical, for both T0 and T4 paths, except: A. The master output clock is the highest priority input on the slave ⁽¹⁾ B. The slave output clock is disabled (priority 0) on the master This ensures that the frequency of the slave matches the frequency of the master.
3.	Any input declared invalid in one device (VALSR registers) must be marked invalid by software in the other device (VALCR registers). This and item 2 together ensure that when the master is performing properly, the slave locks to the master, and when the master fails, the slave locks to the input clock the master was previously locked to.
4.	The slave's T0 DPLL bandwidth should be set higher than the master's (TOLBW, TOABW registers) to ensure that the slave follows any transients coming from the master. (70Hz is recommended.)
5.	Phase build-out should be disabled (MCR10:PBOEN = 0 and PHMON:PMPBEN = 0) on the slave when it is locked to the master to ensure that the slave maintains phase lock with the master. This also allows the use of phase offset (OFFSET registers) to compensate for delays between master and slave.
6.	Revertive mode should be enabled on the slave (REVERT = 1 in MCR3) to ensure the slave switches from any other reference to the master as soon as the master's clock is valid.

Note 1: This must be done for the slave's T0 path, but is not necessary for the slave's T4 path. In the slave's T4 path the input clock priorities should match those of the master except the input connected to the master's output clock should be disabled. This causes the slave's T4 path to only lock to external references.

7.9.1 Master-Slave Pin Feature

Some of the elements of redundancy configuration listed in [Table 7-14](#) are automatically handled in the device when the master-slave pin feature is used (MASTSLV). When this feature is supported in a system, one output clock of the master device must be wired to input clock IC11 on the slave device, and one output clock of the slave device should be wired to IC11 on the master device. This cross-wiring allows the system to dynamically configure either device as master and the other as slave.

When the MASTSLV pin is wired low on one device, that device is configured as the slave. The other device must be configured as the master by wiring its MASTSLV pin high. In each device the state of the MASTSLV pin is always indicated in the read-only MASTSLV bit in register [MCR3](#).

The slave device (MASTSLV = 0) is automatically configured as follows:

- The priority of input clock IC11 is set to 1 (highest) ([IPR6:PRI11\[3:0\]](#) = 0001).
- Phase build-out is disabled ([MCR10:PBOEN](#) = 0).
- Revertive mode is enabled ([MCR3:REVERT](#) = 1).
- T0 DPLL bandwidth is forced to the acquisition setting (i.e., to the setting in the [TOABW](#) register, which should be set to a high bandwidth by software).

In the master device (MASTSLV = 1), none of these settings are forced to specific values. Rather, each setting is configured as needed for normal operation of the system. During configuration, software should configure the master to disable (priority 0) input clock IC11 and should configure the remaining input clock priorities identically in master and slave. During operation, software must maintain matching input clock priorities, as described in item 3 of [Table 7-14](#).

The master-slave pin feature is optional and can be disabled by wiring the MASTSLV pin high on both devices. If this feature is disabled, all the elements of equipment redundancy listed in [Table 7-14](#) must be configured and maintained by software.

7.9.2 Master-Slave Output Clock Phase Alignment

When the T0 DPLL is locked to a selected reference with frequency f , any output clocks derived from T0 with frequency f are phase aligned with the selected reference (if phase build-out is disabled). Any output clocks derived from T0 with frequency greater than f are “falling edge aligned” with the frequency- f output clock. Any output clocks derived from T0 with frequency less than f may or may not be aligned, depending on whether or not their frequencies are integer sub-multiples of f . These statements also apply to output clocks derived from the T4 DPLL.

Given this information, if master and slave devices are cross-wired with 19.44MHz clocks, for example, the output clocks at $N \times 19.44\text{MHz}$ ($N = 1, 2, 4, 8, \text{ or } 16$) from the two devices are phase-aligned with one another. Output clocks at lower frequencies (6.48MHz, 1.544MHz, 2.048MHz, 2kHz, 8kHz, etc.) from the two devices would not necessarily be phase aligned. In many systems, lack of phase alignment between the two devices at these clock rates is not an issue. In some systems, however, the 2kHz and/or 8kHz clocks of the two devices must be aligned to avoid framing errors during switchover between master and slave.

One way to align the 2kHz and/or 8kHz clocks of the master and slave devices is to configure the slave to lock to a 2kHz or 8kHz output of the master. Another way is to use the SYNC2K input as described in [Section 7.9.3](#).

7.9.3 Master-Slave Frame and Multi-Frame Alignment with the SYNC2K Pin

With this method of aligning the 2kHz and 8kHz clocks of the master and slave devices, both a higher-speed clock (such as 6.48MHz or 19.44MHz) and a frame-sync signal (normally 2kHz) from the master are passed to the slave (and vice versa when their roles are reversed). The higher-speed clock from the master is connected to a regular input clock pin on the slave, such as IC11, while the frame-sync signal from the master is connected to the SYNC2K pin on the slave. The slave locks to the higher-speed clock and samples the frame-sync signal on SYNC2K. The slave then uses the SYNC2K signal to falling-edge align some or all of the output clocks. Only the falling edge of SYNC2K has significance. A 4kHz or 8kHz clock can also be used on SYNC2K without any changes to the register configuration, but only output clocks of 8kHz and above are aligned in this case. Phase build-out should be disabled on the slave (PBOEN = 0 in [MCR10](#)), and the higher-speed input clock on the slave must be configured for direct-lock mode (ICR:DIVN = 0 and LOCK8K = 0).

Sampling. By default the SYNC2K signal is first sampled on the rising edge of the selected reference. This gives the most margin, given that the SYNC2K signal is falling-edge aligned with the selected reference since both come from the master device. The expected timing of SYNC2K with respect to the sampling clock can be adjusted from 0.5 cycles early to 1 cycle late using the [FSCR2:PHASE\[1:0\]](#) field.

Resampling. The SYNC2K signal is then resampled by an internal clock derived from the T0 DPLL. The resampling resolution is a function of the frequency of the selected reference and [FSCR2:OCN](#). When OCN = 0, the resampling resolution is 6.48MHz, which gives the highest sampling margin and also aligns clocks at 6.48MHz and multiples thereof. When OCN = 1, if the selected reference is 19.44MHz then the resampling resolution is 19.44MHz. If the selected reference is 38.88MHz then the resampling resolution is 38.88MHz. The selected reference must be either 19.44MHz or 38.88MHz.

SYNC2K Enable. The SYNC2K signal is only allowed to align output clocks if the T0 DPLL is locked and SYNC2K is enabled and qualified. SYNC2K can be enabled automatically or manually. When [MCR3:AEFSEN](#) = 1, SYNC2K is enabled automatically when EFSEN = 1 and the T0 DPLL is locked to the input clock specified by [FSCR3:SOURCE\[3:0\]](#). When AEFSEN = 0, SYNC2K is enabled manually when [MCR3:EFSEN](#) = 1 and disabled when EFSEN = 0. In manual mode when EFSEN = 1, [FSCR3:SOURCE\[3:0\]](#) is ignored and SYNC2K is always enabled regardless of which input clock is the selected reference.

SYNC2K Qualification. SYNC2K is qualified when it has consistent phase and correct frequency. Specifically, SYNC2K is qualified when its significant edge has been found at exact 2kHz boundaries (when resampled as described above) for 64 SYNC2K cycles in a row. SYNC2K is disqualified when one significant edge is not found at the 2kHz boundary.

Output Clock Alignment. When T0 is locked and SYNC2K is enabled and qualified, SYNC2K can be used to falling-edge align the T0-derived output clocks. Output clocks OC10 and OC11 share a 2kHz alignment generator, while the rest of the T0-derived output clocks share a second 2kHz alignment generator. When SYNC2K is not enabled or is not qualified, these 2kHz alignment generators free-run with their existing 2kHz alignments. When SYNC2K is enabled and qualified, the OC10/OC11 2kHz alignment generator is always synchronized by SYNC2K, and therefore OC10 and OC11 are always falling-edge aligned with SYNC2K. When [FSCR2:INDEP](#) = 0, the T0 2kHz alignment generator is also synchronized with the OC10/OC11 2kHz alignment generator to falling-edge align all T0-derived output clocks with SYNC2K. When INDEP = 1, the T0 2kHz alignment generator is not synchronized with the OC10/OC11 2kHz alignment generator and continues to free-run with its existing 2kHz alignment. This avoids any disturbance on the T0-derived output clocks when SYNC2K has a change of phase position.

Frame Sync Monitor. The frame sync monitor signal [OPSTATE:FSMON](#) operates in two modes, depending on the setting of the enable bit ([MCR3:EFSEN](#)).

When EFSEN = 1 (SYNC2K enabled) the FSMON bit is set when SYNC2K is not qualified and cleared when SYNC2K is qualified. If SYNC2K is disqualified then both 2kHz alignment generators are immediately disconnected from SYNC2K to avoid phase movement on the T0-derived outputs clocks. When [OPSTATE:FSMON](#) is set, the latched status bit [MSR3:FSMON](#) is also set, which can cause an interrupt if enabled. If SYNC2K immediately stabilizes at a new phase and proper frequency, then it is requalified after 64 2kHz cycles (nominally 32ms). Unless system software intervenes, after SYNC2K is requalified the 2kHz alignment generators will synchronize with SYNC2K's new phase alignment, causing a sudden phase movement on the output clocks. System software can

avoid this sudden phase movement on the output clocks by responding to the FSMON interrupt within the 32ms window with appropriate action, which might include disabling SYNC2K (`MCR3:EFSEN = 0`) to prevent the resynchronization of the 2kHz alignment generators with SYNC2K, forcing the slave into holdover (`MCR1:T0STATE = 010`) to avoid affecting the output clocks with any other phase hits, and possibly even disabling the master and promoting the slave to master (see Section 7.9.1) since the 2kHz signal from the master should not have such phase movements.

When `EFSEN = 0` (SYNC2K disabled) `OPSTATE:FSMON` is set when the negative edge of the re-sampled SYNC2K signal is outside of the window determined by `FSCR3:MONLIM` relative to the OC11 negative edge (or positive edge if OC11 is inverted) and clear when within the window. When `OPSTATE:FSMON` is set, the latched status bit `MSR3:FSMON` is also set, which can cause an interrupt if enabled.

Other Frame Sync Configuration Options. OC10 and OC11 are always produced from the T0 path. Output clocks OC1 to OC7 can also be configured as 2 kHz or 8 kHz outputs, derived from either the T0 path or the T4 path (as specified by the 2K8KSRC bit in `FSCR1`). If needed, the T4 DPLL can be used as a separate DPLL for the frame sync path by configuring it for a 2kHz input and 2kHz and/or 8 kHz frame sync outputs.

7.10 Multiprotocol BITS Transceivers

The DS3100 has two identical, independent BITS transceivers, each of which support the following synchronization protocols:

- DS1 (also configurable for J1)
- E1
- 2048kHz (G.703)
- 6312kHz (G.703)*

*The BITS receivers can receive the 6312kHz signal, but the transmitters do not transmit this protocol because it is easily generated using any of output clocks OC1 through OC7 and an external square-to-sinusoidal network.

The [BMCR](#) register description and accompanying footnotes give additional details on these synchronization protocols and the telecom standards with which they comply. [Figure 7-7](#) shows the BITS transceiver block diagram.

Figure 7-7. BITS Transceiver Block Diagram

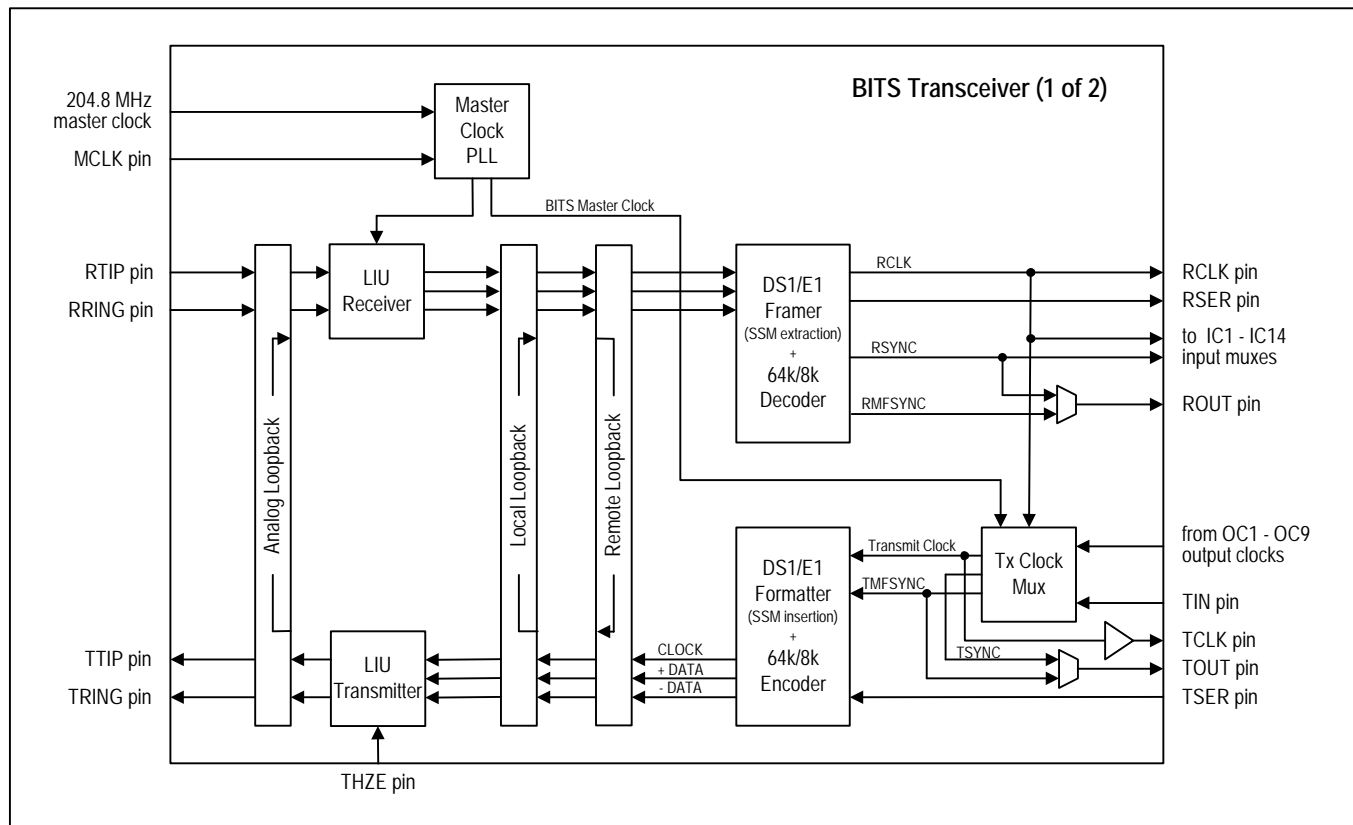

Note: The DS3100 BITS transceivers are full-featured DS1/E1 LIUs and framers. To keep configuration as simple as possible, only the features most commonly used for clock synchronization applications are made visible in this data sheet. If your application requires LIU or framer features not described in this document, contact the factory at www.maxim-ic.com/support for additional information.

7.10.1 Master Clock Connections

See Figure 7-7 and Figure 7-8. The master clock PLL block produces two clocks: (1) a 16X line rate oversampling clock for the receiver, and (2) the BITS master clock, which can optionally be used by the transmitter. Both of these clocks are made from the same BITS transceiver master clock. There are two possible sources for the BITS master clock: the 204.8MHz master clock and the MCLK input pin. Normally `BCCR3:MCLKS` is set to 0, to select the 204.8MHz master clock (see Section 7.3) divided by 100. The resulting 2.048MHz clock can be used as-is for E1 and 2048kHz synchronization or fed into a 2.048MHz to 1.544MHz frequency converter PLL for DS1 synchronization.

For special applications, `MCLKS` can be set to 1 to source the BITS transceiver master clock from the MCLK pin. When `MCLKS` = 1, the signal on the MCLK pin is divided by 1, 2, 4, or 8 (as specified by `BCCR5:MPS[1:0]`) and optionally passed through the 2.048MHz to 1.544MHz frequency-converter PLL (as specified by `BCCR3:MCLKFC`). For any BITS receiver mode, the signal on the MCLK pin can be 1, 2, 4, or 8 times 2.048MHz. For DS1 mode only, MCLK can be 1, 2, 4, or 8 times 1.544MHz. When `MCLKS` = 0, the MCLK pin is ignored and should be wired high or low.

Figure 7-8. BITS Transceiver Master Clock PLL Block Diagram

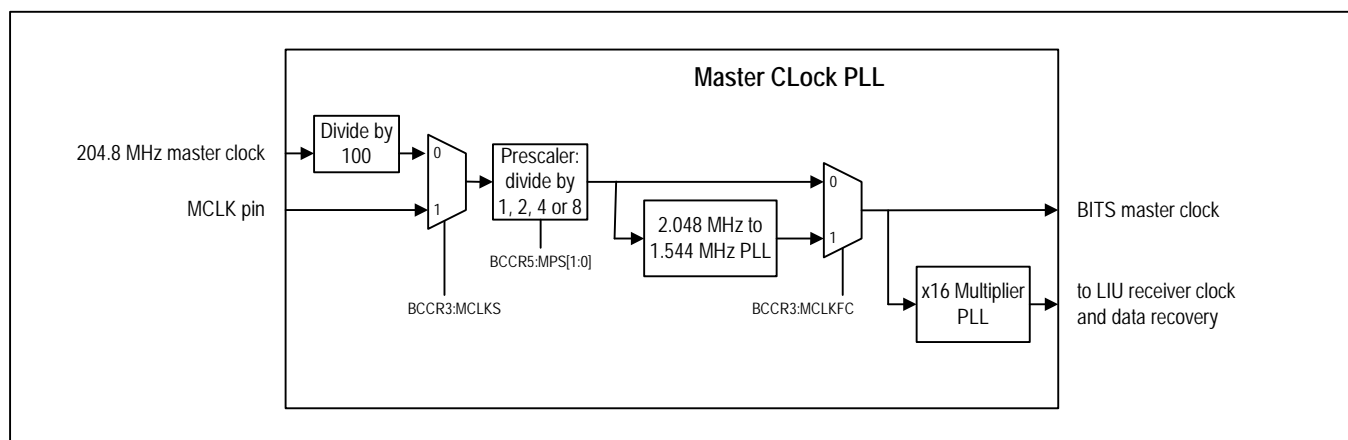

7.10.2 Receiver Clock Connections

See Figure 7-7. The BITS receiver typically forwards its recovered clock to one of input clocks IC1 through IC14. The `RCLKD` field in `BCCR2` specifies the destination. The input clock that is selected as the destination considers the BITS receiver to be its clock source and ignores the signal at its own input pin. For input clocks IC1, IC2, IC5, and IC6, the signal from the BITS receiver is inserted after the AMI/LVDS/LVPECL input logic.

For DS1, E1 and 2048kHz BITS receiver modes, typically the recovered clock is forwarded to one of the ICx input clocks by configuring `BCCR2:RCLKD` to specify the input clock and configuring the input clock for 1544kHz or 2048kHz as described in Section 7.4.2. The recovered clock can be output on the RCLK pin if needed by setting `BCCR3:RCEN` = 1 to enable the pin. Optionally the frame sync of the incoming DS1/E1 signal can be forwarded to one of the ICx input clocks by configuring `BCCR2:RSYNCD` to specify the input clock and configuring the input clock for 8kHz as described in Section 7.4.2. Also, the DS1/E1 frame sync or multiframe sync can be output on the ROUT pin by setting `BCCR3:ROUTS` appropriately and setting `BCCR3:ROEN` = 1 to enable the pin. The frame sync signal is normally low and pulses high for one RCLK cycle during the framing bit (DS1) or the first FAS bit (E1). The multiframe sync signal is normally low and pulses high for one RCLK cycle on the first bit of the multiframe. In E1 modes, the type of multiframe sync (CAS or CRC-4) can be specified in `BCCR5:RMFS`. The polarity of RCLK and ROUT can be inverted by setting `BCCR3:RCINV` and `ROINV`, respectively.

Since the BITS clock and frame sync signals are rising edge oriented and the DPLL clocks are falling edge oriented, all clock and sync signals from the BITS receiver are inverted before being used by the DPLL. When the DPLL is locked to a clock or sync signal from a BITS receiver, the DPLL output clocks are falling-edge aligned with the rising edge of the input signal. If the T0 DPLL is locked to a frame sync signal from a BITS receiver, the falling

edge of the OC10 frame sync signal is aligned to the rising edge of the RSYNC signal, and if the OC10 pin is set to pulse mode, the OC10 pulse is closely aligned with the RSYNC pulse.

For 6312kHz BITS receiver mode, the recovered clock can be forwarded to one of the ICx input clocks by configuring **BCCR2:RCLKD** to specify the input clock and configuring the input clock for 6312kHz using the DIVN locking mode with $DIVN = 788$. Optionally the recovered 6312kHz clock can be output on the RCLK pin by setting **BCCR3:RCEN** = 1 to enable the pin.

If both BITS receivers are used simultaneously, they should specify different ICx input clocks as destinations in their RCLKD and RSYNCD fields. If any two or more of these fields specify identical destinations then RCLK from BITS receiver 1 takes precedence, followed by RSYNC from BITS receiver 1, then RCLK from BITS receiver 2 then RSYNC from BITS receiver 2.

If a BITS receiver detects a defect (e.g., BPVs, EXZs, LOS, AIS, OOF) in the incoming signal, two methods can be used to invalidate the ICx input clock(s) to which the BITS receiver is connected. The first method is to poll the BITS receiver status registers, or react to interrupt requests from those registers, and, if a significant defect is discovered, invalidate the input clock(s) by clearing the corresponding bit in the **VALCR1** and **VALCR2** registers.

The second method is to configure the device to automatically react when defects are detected. For LOS, AIS and OOF, if the corresponding enable bits are set in **BCCR5**, then the associated ICx input clock(s) are automatically marked invalid in the **VALSR** registers when defects occur. For BPVs and excessive zeros (EXZs), if the corresponding enable bits are set in **BCCR5**, then these defects are considered irregularities by the activity monitors of the associated ICx input clock(s). See Section 7.5.2 for more information on the activity monitors.

Note that RCLK and RSYNC are automatically squelched by the BITS receiver during LOS. If either RCLK or RSYNC happens to be the selected reference when LOS occurs, the fast activity monitor in the DPLL (Section 7.5.3) detects the lack of transitions caused by the squelching within two cycles and causes the DPLL to enter mini-holdover mode until the selected reference returns or is invalidated by the DPLL input clock monitors. If ultra-fast switching mode is enabled (**MCR10:UFSW** = 1, see Section 7.6.4), then the fast activity monitor immediately invalidates the clock and switches to a new reference or to holdover mode if no other input clock is valid. RCLK is squelched in the paths to the RCLK output pin and the ICx input monitoring circuitry, but it is not squelched in the receive framer clock tree.

Figure 10-4 and Table 10-11 show the timing relationships among RCLK, ROUT, and RSER.

Figure 7-9. BITS Transmitter Clock Mux Block Diagram

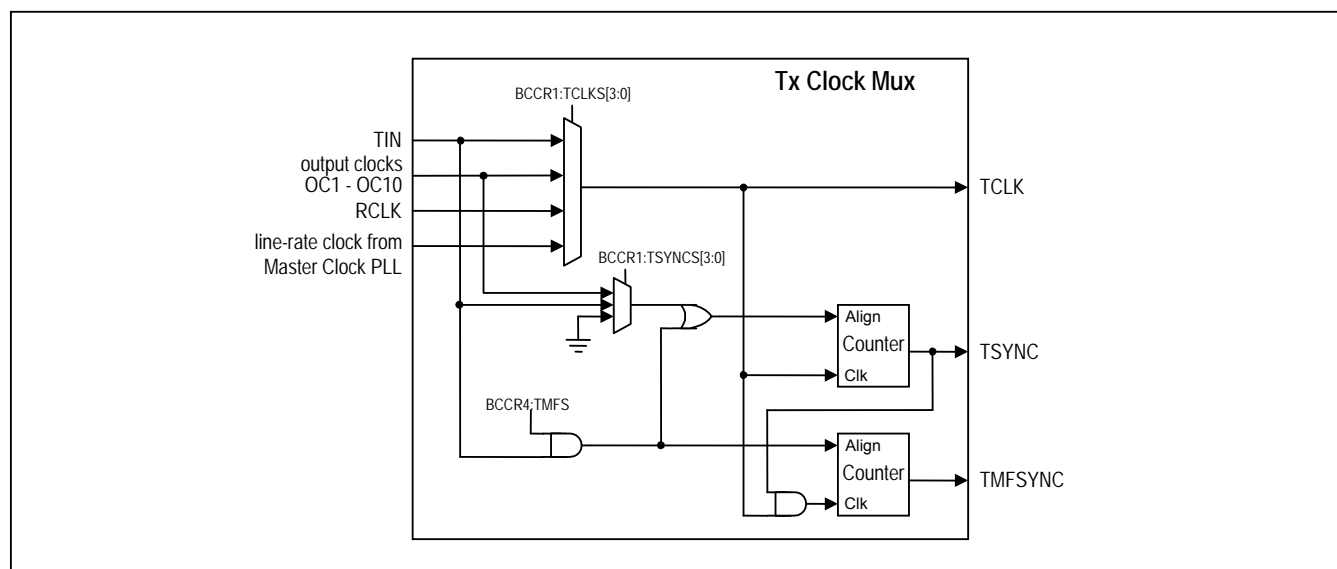

7.10.3 Transmitter Clock Connections

See [Figure 7-7](#) and [Figure 7-9](#). The `BCCR1:TCLKS` field specifies the source for the BITS transmitter clock (TCLK). Typically TCLK is sourced from one of DPLL output clocks OC1–OC7 or OC9 (configured for 1544kHz or 2048kHz as described in [Section 7.8.2](#)).

In DS1 and E1 modes the BITS transmitter also requires a frame sync and/or multiframe sync signal to specify the start of the frame or multiframe. The frame sync signal is normally low and pulses high for one TCLK cycle on the first bit of the frame. The multiframe sync signal is normally low and pulses high for one TCLK cycle on the first bit of the multiframe. The frame sync (TSYNC) signal is created in the Tx Clock Mux block by a counter circuit that outputs a signal that is normally low and pulses high for one TCLK cycle out of every 193 (DS1 mode) or 256 (E1 mode). The multiframe sync (TMFSYNC) signal is then created by another counter circuit that outputs a signal that is normally low and pulses high coincident with one TSYNC pulse out of every 12 (DS1 SF mode), 24 (DS1 ESF mode, or 16 (E1 mode). In many applications the DS1/E1 frame sync and multiframe sync signals are not required to be aligned with any other signal (other than rising-edge aligned to TCLK and each other), and therefore, by default, the TSYNC and TMFSYNC counter circuits are allowed to free-run without being aligned by an input signal (`BCCR1:TSYNCS = 1111`, `BCCR4:TMFS = 0`).

For applications that require it, the leading edge of the TSYNC pulse can be aligned with a clock edge from one of DPLL output clocks OC1–OC7 or OC10 or the BITS transmitter's TIN input pin. The `BCCR1:TSYNCS` field specifies the source of the clock used to align TSYNC. For proper operation, the TSYNC source and the TCLK source must be frequency locked. Because the TSYNC counter circuit free-runs when not being actively aligned by an input signal, the TSYNC source clock can pulse just one time to establish TSYNC alignment or it can be a steady clock with a frequency of 8kHz or any integer divider of 8kHz. Duty cycle is not important for the TSYNC source clock.

For applications that require it, the TMFSYNC pulse can be aligned with a clock edge from the BITS transmitter's TIN input pin by setting `BCCR4:TMFS = 1`. Because the TMFSYNC counter circuit free-runs when not being actively aligned by an input signal, the TMFSYNC source clock can pulse just one time to establish TMFSYNC alignment or it can be a steady clock with a frequency of $8\text{kHz} / X$ (where X is 12 for DS1 SF mode, 24 for DS1 ESF mode, and 16 for E1 mode) or any integer divider of $8\text{kHz} / X$. When the TMFSYNC pulse is aligned by a clock edge on the TIN pin, the TSYNC signal is automatically aligned as well to maintain frame/multiframe alignment (see the OR gate in [Figure 7-9](#)). Duty cycle is not important for the TMFSYNC source clock.

When a DPLL output clock is selected as a clock source for TCLK or TSYNC, the output clock signal is forwarded to the BITS transmitter without being affected by any configuration settings that disable, invert, or convert-to-pulse the signal output on the OCx output clock pin. Because the DPLL output clocks are falling-edge oriented and the BITS transmitter clock and frame sync signals are necessarily rising edge oriented, the DPLL clock signals specified by `BCCR1:TCLKS` and `BCCR1:TSYNCS` are inverted between the DPLL and the BITS transmitter so that the falling edge(s) of the DPLL output clock(s) are aligned to the rising edges of the TCLK and TSYNC (and TMFSYNC) signals. When OC10 is selected as the alignment signal for TSYNC and configured in pulse mode, the leading and trailing edges of the OC10 pulse are aligned with the leading and trailing edges of the TSYNC signal in the BITS transmitter.

The TCLK signal can be output on the TCLK pin by setting `BCCR4:TCEN = 1` to enable the pin. Optionally, the TSYNC signal or the TMFSYNC signal can be output on the TOUT pin by specifying the signal with `BCCR4:TOUTS` and setting `BCCR4:TOEN = 1` to enable the pin. The polarity of the TIN, TCLK and TOUT pins can be inverted by setting `BCCR4:TIINV`, `TCINV` and `TOINV`, respectively.

As can be seen from [Figure 7-9](#), the typical setups described above are just a few of the possible BITS transmitter clock configurations. As the figure shows, both the recovered clock from the BITS receiver (RCLK) and the line rate clock from the master clock PLL are possible clock sources for the BITS transmitter TCLK. Using an OCx output pin and the TIN input pin, the BITS transmitter clock signal can be externally filtered or otherwise adjusted before being sent out through the BITS transmitter. If needed, the TCLK and TOUT output pins can be enabled—by setting `TCEN = 1` and `TOEN = 1`, respectively, in `BCCR4`—to pass key BITS transceiver clocks to external circuitry. Finally, the data content of the DS1 or E1 frame can be sourced from the TSER pin if needed. [Figure 10-5](#) and [Table 10-12](#) show the timing relationships among TCLK, TIN, TOUT, and TSER.

7.10.4 Line Interface Unit

The line interface unit (LIU) contains the receiver, which recovers clock and data from the inbound cable, and the transmitter, which wave-shapes and drives the signal onto the outbound cable. These sections are controlled by the line interface control registers, [BLCR1](#) through [BLCR4](#).

The receiver has a usable receive sensitivity of 0dB to -43dB for E1 and 0dB to -36dB for DS1, which allows the device to operate on 0.63mm (22AWG) cables up to 2.5 km (E1) and 6000 feet (DS1) in length. The transmitter line driver can handle both CEPT 30/ISDN-PRI lines for E1 and long-haul (CSU) or short-haul (DSX-1) lines for DS1.

The receiver and transmitter can switch among the supported synchronization signal types without changing external components. [Figure 7-10](#) shows the minimum set of external components required. Both the receiver and the transmitter can adjust their termination impedance to provide high return loss characteristics for 75Ω, 100Ω, 110Ω, and 120Ω lines. Other components may be added to this configuration in order to meet safety and network protection requirements, if required.

Figure 7-10. BITS Transceiver External Components

Internal Receiver Termination Enabled

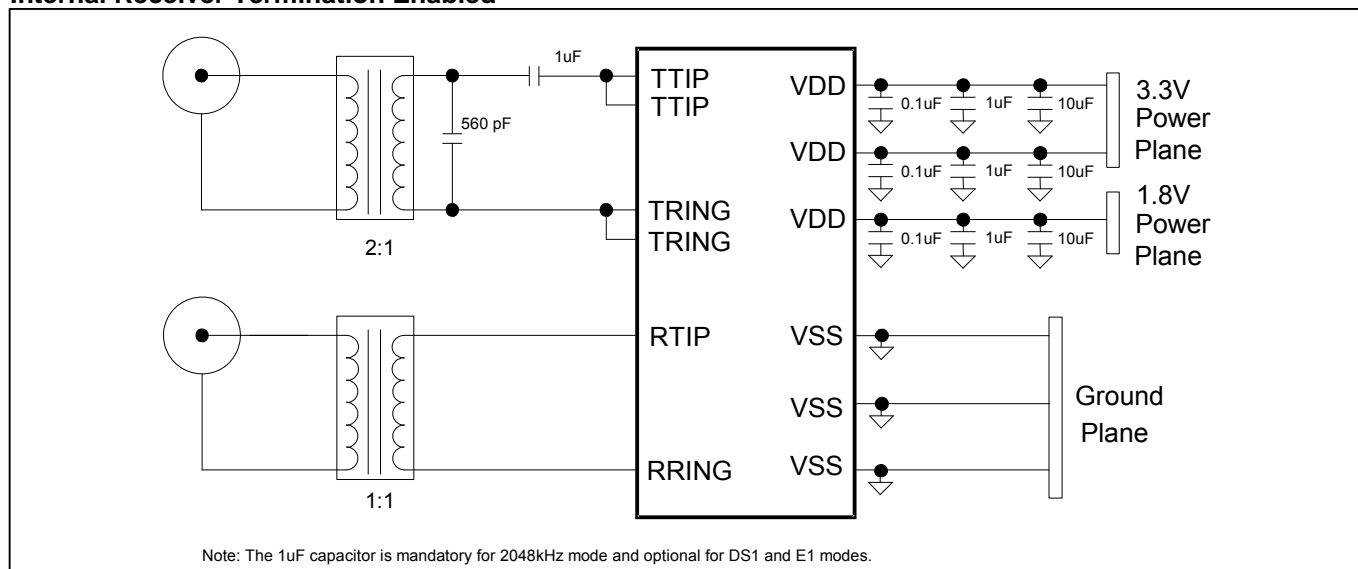

Internal Receiver Termination Disabled

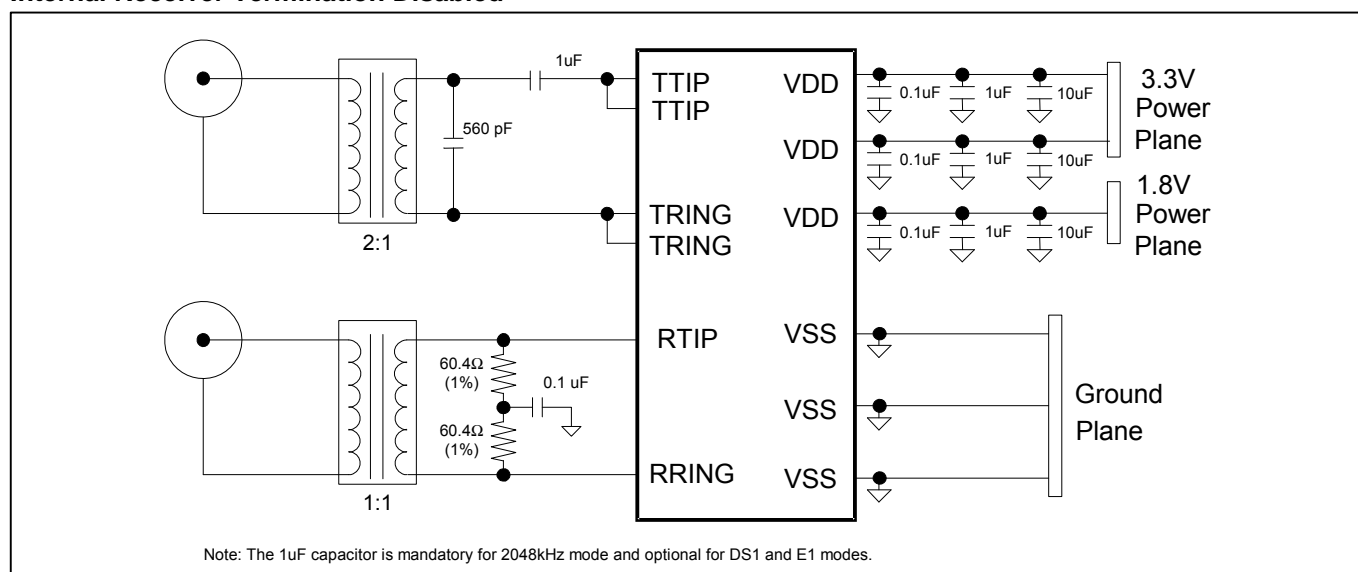

7.10.4.1 Receiver

7.10.4.1.1 Interfacing to the Line

The receiver can be transformer-coupled or capacitor-coupled to the line. Typically, the receiver interfaces to the incoming coaxial cable or twisted-pair wiring through a 1:1 isolation transformer. Figure 7-10 shows the arrangement of the transformer with either internal termination or external termination. For internal termination, set `BLCR3:RION = 1` and set `BLCR3:RIMP[1:0]` to specify the termination impedance. For external termination, set `BLCR3:RION = 0` and use external termination resistors as shown in Figure 7-10. Table 7-15 specifies the required characteristics of the transformer.

7.10.4.1.2 Receive Sensitivity

Receive sensitivity can be adjusted in DS1, E1, and 2048kHz modes using `BLCR3:RSMS[1:0]`. In 6312kHz mode, receive sensitivity is fixed at approximately -24dB.

7.10.4.1.3 Receive Level Indicator

The signal strength at RTIP/RRING is reported in 2.5dB increments in `BLIR2:RL[3:0]`. This feature is helpful when troubleshooting line performance problems.

7.10.4.1.4 Optional Monitor Mode

The receiver can be used in monitoring applications, which typically have flat losses from the use of series resistors. In these applications a pre-amp stage in the receiver can be configured to apply 14dB, 20dB, 26dB, or 32dB of flat gain to compensate for the resistive losses. The monitor mode preamp is enabled by setting `BLCR3:RMONEN = 1` and configured by `BLCR3:RSMS[1:0]`.

7.10.4.1.5 Clock and Data Recovery

The BITS receiver has an active filter that reconstructs the received analog signal for the nonlinear losses that occur in transmission. The BITS master clock (Section 7.10.1) is multiplied by 16 and used as the master clock for the APLL used in the receiver to recover clock and data. The receiver has excellent jitter tolerance as shown in Figure 7-11 and Figure 7-12.

Figure 7-11. Jitter Tolerance, DS1 Mode

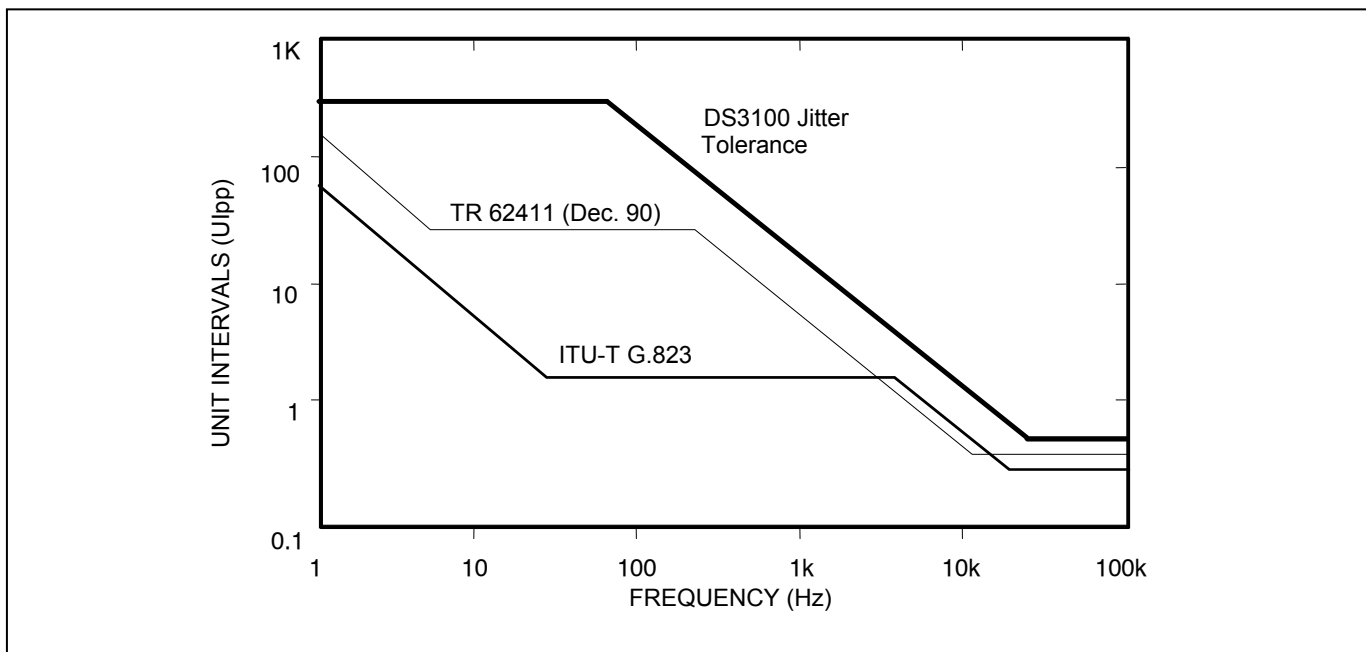
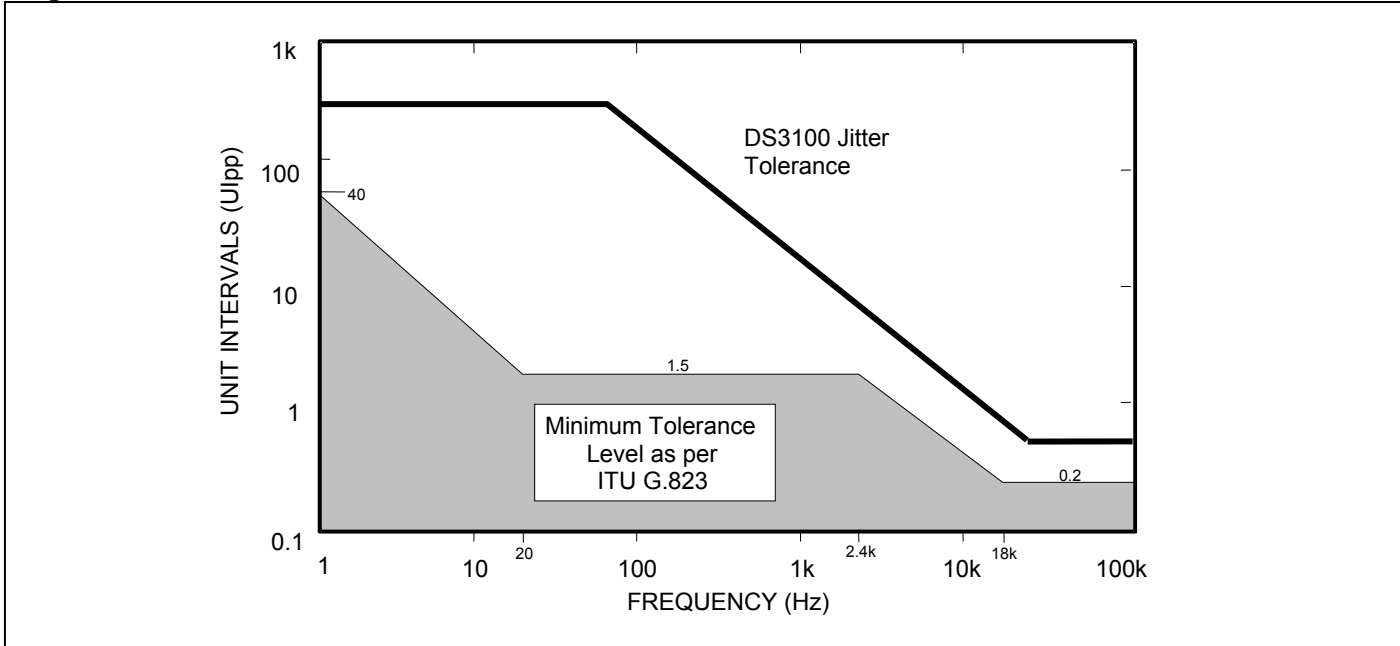

Figure 7-12. Jitter Tolerance, E1 and 2048kHz Modes

7.10.4.1.6 Loss-of-Signal Detection

In DS1 mode, LOS is declared when no pulses are detected (i.e., when the signal level is 6dB below the receive sensitivity level set by **BLCR3:RSMS[1:0]**) in a window of 192 consecutive pulse intervals. When LOS occurs, the receiver sets the real-time LOS status bit in **BLIR1** and the latched LOS status bit in **BLSR1**. **BLSR1:LOS** in turn can cause an interrupt request on the INTREQ pin if enabled by **BLIER1:LOS**. LOS is cleared when 24 or more pulses are detected (amplitude greater than receive sensitivity minus 4dB) in a 192-bit period (pulse density above 12.5%) and there are no occurrences of 100 or more consecutive zeros during that period. This algorithm meets the requirements of ANSI T1.231. For example, if receive sensitivity is set at 18dB below nominal (**BLCR3:RSMS[1:0]**), the LOS set threshold is 24dB below nominal, and the LOS clear threshold is 22dB below nominal.

In E1 and 2048kHz modes, if **BLCR1:LCS = 0** the receiver is configured for ITU G.775 LOS detection. When configured in this manner, LOS is declared when no pulses are detected (i.e., when the signal level is 6dB below the receive sensitivity level set by **BLCR3:RSMS[1:0]**) in a window of 255 consecutive pulse intervals. When LOS occurs, the receiver sets the real-time LOS status bit in **BLIR1** and the latched LOS status bit in **BLSR1**. **BLSR1:LOS** in turn can cause an interrupt request on the INTREQ pin if enabled by **BLIER1:LOS**. LOS is cleared when at least 32 pulses are detected (amplitude greater than receive sensitivity minus 4dB) in a window of 255 consecutive pulse intervals.

In E1 and 2048kHz modes, if **BLCR1:LCS = 1** the receiver is configured for ETSI 300 233 LOS detection. When configured in this manner, LOS is declared when no pulses are detected (i.e., when the signal level is 6dB below the receive sensitivity level set by **BLCR3:RSMS[1:0]**) in a window of 2048 consecutive pulse intervals. When LOS occurs, the receiver sets the real-time LOS status bit in **BLIR1** and the latched LOS status bit in **BLSR1**. **BLSR1:LOS** in turn can cause an interrupt request on the INTREQ pin if enabled by **BLIER1:LOS**. LOS is cleared when at least one pulse is detected (amplitude greater than receive sensitivity minus 4dB) in a window of 255 consecutive pulse intervals.

In 6312kHz mode, LOS is declared when the signal level is below -24dBm for a 32μs period.

7.10.4.1.7 Receiver Power-Down

The receiver can be powered down to reduce power consumption by setting **BLCR4:RPD = 1**. When the receiver is powered down, all digital outputs from the receiver are held low, and RTIP and RRING become high impedance.

7.10.4.2 Transmitter

7.10.4.2.1 Waveshaping

The BITS LIU transmitter uses a phase-locked loop along with a precision digital-to-analog converter (DAC) to create the waveforms that are transmitted onto the outbound cable. The waveforms meet the latest ANSI, ETSI, ITU and Telcordia specifications (see [Figure 7-13](#), [Figure 7-14](#), and [Figure 7-15](#)). The `BMCR:TMODE[1:0]` field specifies the waveform to be generated, along with the line build out field in `BLCR2:LBO[2:0]`, if applicable. Due to the nature of its design, the transmitter adds very little jitter (less than $0.005U_{I_{P-P}}$ broadband from 10Hz to 100kHz) to the transmit signal. Also, the waveforms created are independent of the duty cycle of TCLK.

7.10.4.2.2 Line Build-Out

The transmitter line driver can handle both CEPT 30/ISDN-PRI lines for E1 and long-haul (CSU) or short-haul (DSX-1) lines for DS1. The `LBO[2:0]` field in `BLCR2` specifies the line build-out for DS1 and E1.

7.10.4.2.3 Line Driver Enable/Disable

When the THZE pin is high or when `BLCR4:TE = 0`, the transmitter line driver is disabled, and TTIP/TRING are put in a high-impedance state. When the THZE pin is low and `BLCR4:TE = 1`, the line driver is enabled.

7.10.4.2.4 Interfacing to the Line

The transmitter is transformer-coupled to the line. Typically, the transmitter interfaces to the outgoing coaxial cable or twisted-pair wiring through a 1:2 isolation transformer. [Figure 7-10](#) shows the arrangement of the transformer with respect to the TTIP and TRING pins. On the DS3100 the transmitter termination is always internal. Set `BLCR2:TION = 1` and set `BLCR2:TIMP[1:0]` to specify the termination impedance. [Table 7-15](#) specifies the required characteristics of the transformer.

7.10.4.2.5 AIS Generation

When `BLCR4:TAIS = 1`, the transmitter generates AIS (unframed all ones) using the BITS master clock as the timing reference.

7.10.4.2.6 Short-Circuit Detector

The BITS transmitter has an automatic short-circuit detector that activates when the short-circuit resistance is approximately 25Ω or less. `BLIR1:SC` provides a real-time indication of when the short-circuit limit has been exceeded. Latched status bits `BLSR1:SC` and `SCC` are set when `BLIR1:SC` changes state from low-to-high and high-to-low, respectively. These latched status bits can cause an interrupt request if enabled by the corresponding bits in `BLIER1`. The short-circuit detector is disabled for CSU modes (i.e., when `BLCR2:LBO[2:0] = 101, 110, or 111`).

7.10.4.2.7 Open-Circuit Detector

The BITS transmitter can also detect when TTIP and TRING are open circuited. `BLIR1:OC` provides a real-time indication of when the open-circuit limit has been exceeded. Latched status bits `BLSR1:OC` and `OCC` are set when `BLIR1:OC` changes state from low-to-high and high-to-low, respectively. These latched status bits can cause an interrupt request if enabled by the corresponding bits in `BLIER1`. The open-circuit detector is disabled for CSU modes (i.e., when `BLCR2:LBO[2:0] = 101, 110, or 111`).

7.10.4.2.8 Transmitter Power-Down

The transmitter can be powered down to reduce power consumption by setting `BLCR4:TPD = 1`. When the transmitter is powered down, TTIP and TRING are high impedance.

Figure 7-13. Transmit Pulse Template, DS1 Mode

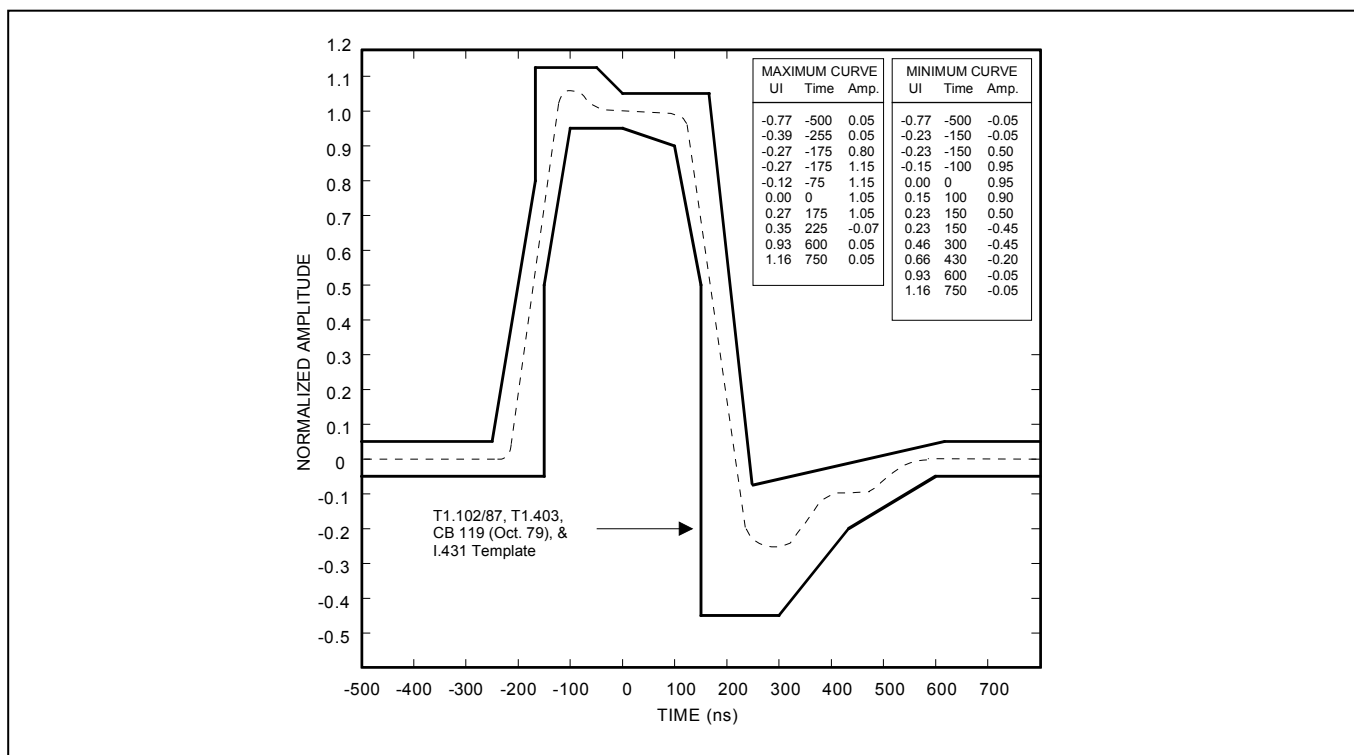

Figure 7-14. Transmit Pulse Template, E1 Mode

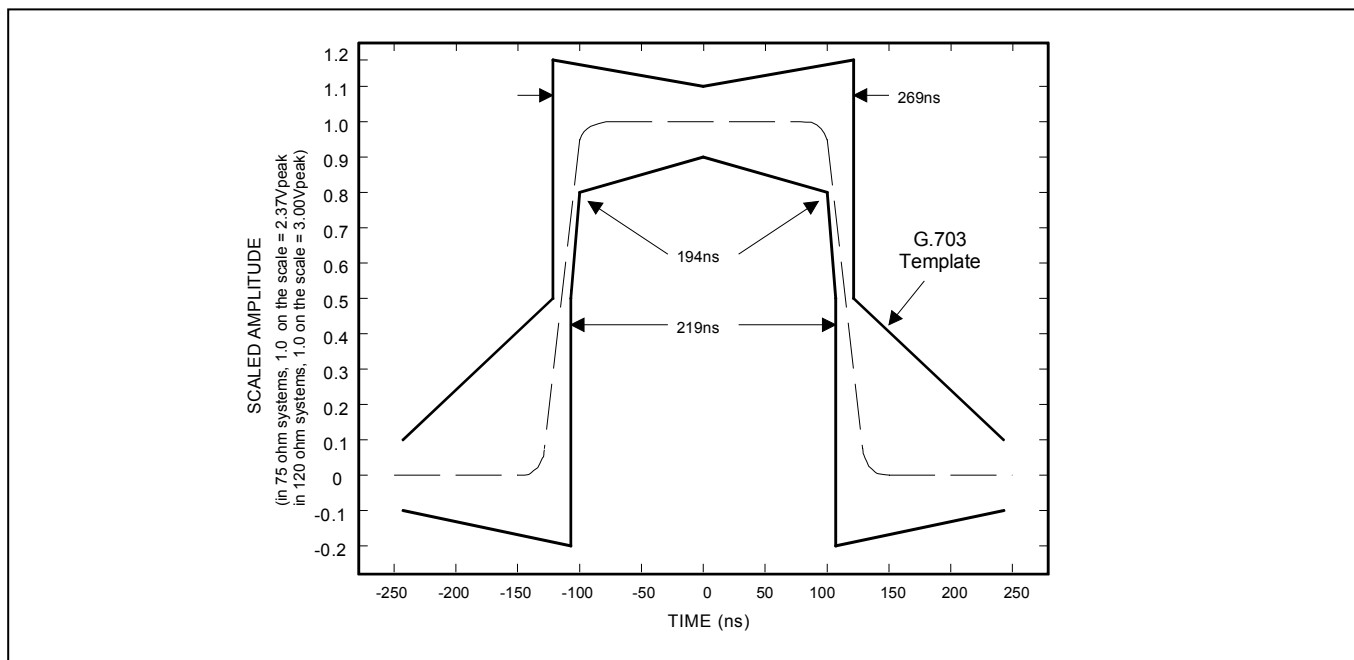
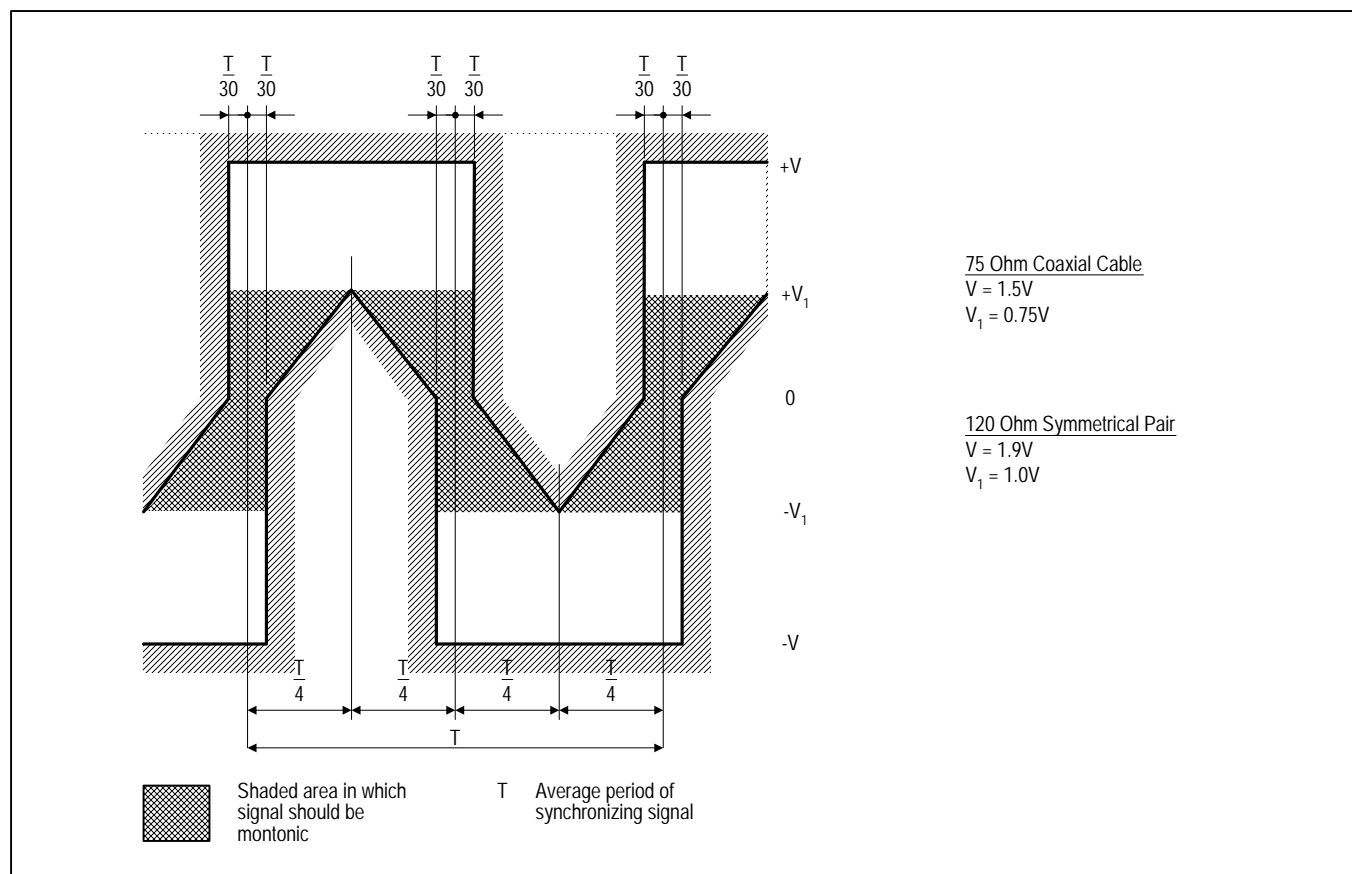

Figure 7-15. Transmit Pulse Template, 2048kHz Mode



7.10.4.3 LIU Loopbacks

The BITS LIU provides three loopbacks for diagnostic purposes: analog loopback, local loopback, and remote loopback. See Figure 7-7. These loopback are enabled by the ALB, LLB, and RLB bits in BLCR4.

7.10.4.4 Component Specifications

Table 7-15. Transformer Specifications

SPECIFICATION		RECOMMENDED VALUE
Turns Ratio	Receiver	1:1 or 2:1 ($\pm 2\%$)
	Transmitter	1:2 ($\pm 2\%$)
Primary Inductance		600 μ H minimum
Leakage Inductance		1.0 μ H maximum
Intertwining Capacitance		40pF maximum
Transmit Transformer DC Resistance	Primary (Device Side)	1.2 Ω maximum
	Secondary	1.2 Ω maximum
Receive Transformer DC Resistance	Primary (Device Side)	1.2 Ω maximum
	Secondary	1.2 Ω maximum
Isolation Voltage		1500 V_{RMS} (min)

Note: Recommended transformers include the Pulse Engineering PE-68678 (0°C to +70°C) and T1094 (-40°C to +85°C), both of which are surface-mount dual transformers (1:1 and 1:2).

7.10.5 DS1 Synchronization Interface

Each BITS transceiver receives and transmits standards-compliant DS1 synchronization signals. As a configuration option of DS1, the BITS transceivers can also be configured for the Japanese J1 interface.

7.10.5.1 Receive Framer

In the receive direction, the BITS transceiver recovers clock and data, does B8ZS decoding, finds frame alignment, and extracts incoming SSM messages. Each BITS receiver can be configured for DS1 mode by following these steps:

- 1) Set the overall mode of the receiver to DS1 by setting **BMCR:RMODE** = 00.
- 2) Configure and enable the DS1/E1 framer in the **BRMMR** register as follows:
 - (a) toggle **RRST** high then low,
 - (b) set **RT1E1** = 0 to configure the framer for DS1 mode,
 - (c) set registers **BRCCR1**, **BRCCR2** and **BRCCR5** as needed,
 - (d) set **REN** = 1 to enable the framer, and
 - (e) set **RID** = 1 to start the framer.
- 3) Configure and enable the LIU receiver as described in Section 7.10.4.1.

Registers **BRCCR1**, **BRCCR2** and **BRCCR5** configure the receive framer in DS1 mode. **BRCCR1:RFM** specifies superframe or extended superframe mode. **BRCCR1:RB8ZS** enables B8ZS decoding. The receive framer can be configured for J1 operation by setting **BRCCR1:RJC** = 1 and **BRCCR2:RSFRAI** = 1. Status register **BRIR1** has real-time status bits to indicate the presence of RAI, AIS, LOS and OOF conditions, while status register **BRSR1** has latched versions of these same status bits. (See Table 7-16 for alarm set and clear criteria.) The onset or clearing of any of these events can cause an interrupt request on the INTREQ pin if enabled to do so by the corresponding enable bits in the **BRIER1** register. Status registers **BRSR2** and **BRSR4** provide additional status information.

The entire received DS1 data stream is available on the RSER pin for additional processing by external hardware, if needed. RSER is updated on the rising edge of the RCLK pin by default, but this can be changed to the falling edge by setting **BCCR3:RCINV** = 1.

Table 7-16. DS1 Alarm Criteria

ALARM		SET CRITERIA	CLEAR CRITERIA
AIS (Note 1)		Four or fewer 0s are received during a 3ms window.	Five or more 0s are received during a 3 ms window.
RAI	SF Bit-2 Mode (Note 2)	Bit 2 is set to zero in at least 254 of 256 consecutive channel time slots.	Bit 2 is set to zero in less than 254 of 256 consecutive channel time slots.
	SF 12 th F-Bit Mode (Note 2)	The 12th framing bit is set to 1 for two consecutive occurrences.	The 12th framing bit is set to 0 for two consecutive occurrences.
	ESF Mode	16 consecutive patterns of 00FFh appear in the FDL.	14 or fewer patterns of 00FFh appear in 16 consecutive opportunities in the FDL.
LOS		192 consecutive zeros received	14 or more ones received out of 112 possible bit positions, starting with the first one received.
OOF		Two or more errored-frame bits out of every four, five, or six frame bits. (Configured by BRCCR2:OOF [1:0].)	Fewer than two errored-frame bits out of every four, five, or six frame bits. (Configured by BRCCR2:OOF {1:0}.)

Note 1: AIS is an unframed all-ones signal. AIS detectors should be able to operate properly in the presence of a 10^{-3} error rate and must not declare AIS in the presence of a *framed* all-ones signal. The BITS transceiver block has been designed to achieve this performance.

Note 2: In SF framing mode, the RAI type is configured by the RSFRAI bit in the **BRCCR2** register. The method of indicating RAI using the 12th F-Bit in SF mode is also known as Japanese Yellow Alarm.

7.10.5.2 Transmit Formatter

In the transmit direction, the BITS transceiver formats the outgoing data stream, inserts SSM messages, does B8ZS encoding, and drives the outgoing cable with standards-compliant waveshapes. Each BITS transmitter can be configured for DS1 mode by following these steps:

- 1) Set the overall mode of the transmitter to DS1 by setting **BMCR**:TMODE = 00.
- 2) Configure and enable the DS1/E1 framer in the **BTMMR** register as follows:
 - (a) toggle TRST high then low,
 - (b) set TT1E1 = 0 to configure the framer for DS1 mode,
 - (c) set registers **BTCR1**, **BTCR2**, and **BTCR3** as needed,
 - (d) set TEN = 1 to enable the framer, and
 - (e) set TID = 1 to start the framer.
- 3) Configure and enable the LIU transmitter as described in Section 7.10.4.2.

Registers **BTCR1**, **BTCR2**, and **BTCR3** configure the transmit formatter in DS1 mode. **BTCR3**:TFM specifies superframe or extended superframe mode. **BTCR1**:TB8ZS enables B8ZS encoding. The transmit formatter can be configured for J1 operation by setting **BTCR1**:TJC = 1 and **BTCR2**:TSFRAL = 1. In register **BTCR1**, fields TAIS and TRAI control the transmission of AIS and RAI signals, respectively. Status register **BTSR1** provides latched status information from the transmit formatter.

Payload is sourced from the TSER pin. GR-1244-CORE Section 2.4 recommends an all-ones payload, which can be achieved by wiring TSER high. TSER is sampled on the falling edge of the TCLK pin by default, but this can be changed to the rising edge by setting **BCCR4**:TCINV = 1.

7.10.5.3 DS1 SSM Extraction and Insertion

Although synchronization DS1s can have superframe (SF) or extended superframe (ESF) framing format, only DS1s in ESF format can carry SSMs. Therefore, **BTCR3**:TFM must be set for ESF mode to support SSMs in outgoing derived DS1s, while **BRBCR1**:RFM must be set for ESF mode to support SSMs in incoming DS1s from the timing signal generator. In an ESF DS1, SSMs are transmitted in the data link as a bit-oriented code (BOC) (T1.403: "bit-patterned message"). SSMs have the format 0xxxxxx01111111 (right-to-left), where xxxxxx are the six information bits of the message. ANSI standard T1.101 lists the SSM codes carried by DS1 timing signals.

On the receive side, the BITS transceivers each have a dedicated bit-oriented code (BOC) detector, which is always enabled. When the incoming SSM changes, the BOC detector validates it according to the criteria specified by the RBF field in **BRBCR** before declaring it valid. Once validated, the six information bits of the new SSM are written to the lower six bits of the **BRBOC** register, and the BD status bit in **BRSR4** is set to indicate that a new SSM has arrived.

The procedure to receive SSMs is as follows:

- 1) Set the validation filter in **BRBCR**:RBF.
- 2) (Optional) Enable the BD status bit to cause interrupt requests by setting BD = 1 in **BRIER4**.
- 3) Wait for an interrupt request or poll **BRSR4** for BD = 1.
- 4) Read the SSM from the lower six bits of the **BRBOC** register.

If the incoming DS1 signal no longer has a valid BOC, the BOC detector waits for the number of message bits specified by **BRBCR**:RBD[1:0] before declaring that a valid BOC is no longer detected by setting **BRSR4**:BC = 1. The BC field can cause an interrupt request if **BRIER4**:BC = 1.

On the transmit side, the BITS transceivers each have a dedicated BOC generator. When SBOC = 1 in **BTBCR** the BOC generator uses the lower six bits of the **BTBOC** register to continually insert SSMs into the ESF data link. **BTCR1**:TFPT must be set to zero when SBOC = 1.

The procedure to transmit SSMs is as follows:

- 1) Write the 6 information bits of the SSM to the **BTBOC** register.
- 2) Set SBOC = 1 in **BTBCR**.

7.10.6 E1 Synchronization Interface

Each BITS transceiver receives and transmits standards-compliant E1 synchronization signals.

7.10.6.1 Receive Framer

In the receive direction, the BITS transceiver recovers clock and data, does HDB3 decoding, finds frame alignment, and extracts incoming SSM messages. Each BITS receiver can be configured for E1 mode by following these steps:

- 1) Set the overall mode of the receiver to E1 by setting **BMCR:RMODE** = 01.
- 2) Configure and enable the DS1/E1 framer in the **BRMMR** register as follows:
 - (a) toggle **RRST** high then low,
 - (b) set **RT1E1** = 1 to configure the framer for E1 mode,
 - (c) set registers **BRCCR3**, **BRCCR4** and **BRCCR5** as needed,
 - (d) set **REN** = 1 to enable the framer, and
 - (e) set **RID** = 1 to start the framer.
- 3) Configure and enable the LIU receiver as described in Section 7.10.4.1.

Registers **BRCCR3**, **BRCCR4** and **BRCCR5** configure the receive framer in E1 mode. **BRCCR3:RCRC4** enables CRC-4 framing mode. **BRCCR3:RHDB3** enables HDB3 decoding. Status register **BRIR1** has real-time status bits to indicate the presence of RAI, AIS, LOS and OOF conditions, while status register **BRSR1** has latched versions of these same status bits. (See Table 7-16 for alarm set and clear criteria.) The onset or clearing of any of these events can cause an interrupt request on the INTREQ pin if enabled to do so by the corresponding enable bits in the **BRIER1** register. Additional FAS/CAS/CRC-4 frame sync status information is available in register **BRSR3**. See Table 7-18 for E1 sync and resync criteria.

The entire received E1 data stream is available on the RSER pin for additional processing by external hardware, if needed. RSER is updated on the rising edge of the RCLK pin by default, but this can be changed to the falling edge by setting **BCCR3:RCINV** = 1.

Table 7-17. E1 Alarm Criteria

ALARM	SET CRITERIA	CLEAR CRITERIA	ITU SPEC
AIS	Fewer than three zeros in two frames (512 bits)	Three or more zeros in two frames (512 bits)	O.162 1.6.1.2
RAI	Bit 3 of non-FAS frame set to one three consecutive occasions	Bit 3 of non-FAS frame set to zero for three consecutive occasions	O.162 2.1.4
LOS	255 or 2048 consecutive zeros received (determined by BRCCR4:RLOSC)	At least 32 ones received in 255 bit times	G.775 4.2
OOF	See Table 7-18.	See Table 7-18.	—

Table 7-18. E1 Sync and Resync Criteria

FRAME OR MULTIFRAME TYPE	SYNC CRITERIA	RESYNC CRITERIA	ITU SPEC
FAS	FAS present in frames N and N+2 and FAS not present in frame N+1.	If BRCCR3:FRC = 0, three consecutive incorrect FAS. If BRCCR3:FRC = 1, three consecutive incorrect FAS or three consecutive incorrect bit 2 of non-FAS frame	G.706 4.1.1 4.1.2
CRC-4	Two valid multiframe alignment words found within 8ms.	915 or more errored CRC-4 blocks out of 1000.	G.706 4.2 and 4.3.2
CAS	Valid multiframe alignment word found.	Two consecutive multiframe alignment words received in error or, for a period of one multiframe, all the bits in time slot 16 are zero.	G.732 5.2

7.10.6.2 Transmit Formatter

In the transmit direction, the BITS transceiver formats the outgoing data stream, inserts SSM messages, does HDB3 encoding, and drives the outgoing cable with standards-compliant waveshapes. Each BITS transmitter can be configured for E1 mode by following these steps:

- 1) Set the overall mode of the receiver to E1 by setting **BMCR:TMODE** = 01.
- 2) Configure and enable the DS1/E1 framer in the **BTMMR** register as follows:
 - (a) toggle **TRST** high then low,
 - (b) set **TT1E1** = 1 to configure the framer for E1 mode,
 - (c) set registers **BTCR3** and **BTCR4** as needed,
 - (d) set **TEN** = 1 to enable the framer, and
 - (e) set **TID** = 1 to start the framer.
- 3) Configure and enable the LIU transmitter as described in Section 7.10.4.2.
- 4) Configure **BTAF**=1Bh and **BTNAF**=40h to set up the transmit E1 framing overhead.

Registers **BTCR3** and **BTCR4** configure the transmit formatter in E1 mode. **BTCR4:TCRC4** enables CRC-4 framing mode. **BTCR4:THDB3** enables HDB3 encoding. **BTCR4:TAIS** controls the transmission of the AIS signal. Status register **BTSR1** provides latched status information from the transmit formatter.

Payload, and optionally overhead bits, can be sourced on the **TSER** pin from external hardware, if needed. **TSER** is sampled on the falling edge of the **TCLK** pin by default, but this can be changed to the rising edge by setting **BCCR4:TCINV** = 1.

7.10.6.3 Basic FAS/Si/RAI/Sa Insertion and Extraction

The most basic E1 framing is a double frame consisting of an align frame followed by a non-align frame. The align frame is the E1 frame containing the frame alignment signal (FAS) while the non-align frame is the E1 frame that does not contain the FAS.

On the receive side, the **BRAF** and **BRNAF** registers always report the contents of the first eight bits of the align frame and the non-align frame, respectively. Both registers are updated at the start of the align frame, which is indicated by the **RAF** status bit in **BRSR3**. After **RAF** is set to 1, software has 250µs to read the registers before they are overwritten by the bits from the next double-frame.

On the transmit side, the **BTAF** and **BTNAF** registers can source the first eight bits of the align frame and the non-align frame, respectively. Data is sampled from these registers at the start of the align frame, which is indicated by the **TAF** status bit in **BTSR1**. After **TAF** is set to 1, software has 250µs to update the registers with new values (if needed) before they are sampled again for the next double-frame. **BTAF** and **BTNAF** are the default sources for the FAS, Si, RAI and Sa bits. However, various control fields can cause some of these bits to be sourced from elsewhere. Figure 7-16 shows the possible sources and their relative priorities.

7.10.6.4 CRC-4 Multiframe Si/RAI/Sa Insertion and Extraction

On the receive side, the eight registers **BRSa4** through **BRSa8**, **BRSiAF**, **BRSiNAF** and **BRRAI** report the corresponding overhead bits of the CRC-4 multiframe as they are received. These registers are updated at the start of the next CRC-4 multiframe, which is indicated by the **RCMF** status bit in **BRSR3**. After **RCMF** is set to 1, software has 2ms to read the registers before they are overwritten by the bits from the next multiframe.

On the transmit side, the eight registers **BTSa4** through **BTSa8**, **BTSiAF**, **BRSiNAF** and **BTRAI** can source the corresponding overhead bits of the multiframe. The control bits in the **BTOCR** register enable the sourcing of Si/RAI/Sa bits from these registers. Data is sampled from these registers at the start of the multiframe, which is indicated by the **TMF** status bit in **BTSR1**. After **TMF** is set to 1, software has 2ms to update the registers (if needed) before they are sampled again for the next multiframe.

7.10.6.5 SSM Extraction and Insertion

G.704 specifies that synchronization status messages (SSMs) are transmitted in one of the Sa bit channels of the CRC-4 multiframe. All eight instances of the chosen Sa bit within the multiframe are used for the SSM. The four instances of the chosen Sa bit within the first sub-multiframe carry one copy of the SSM, and the four instances within the second sub-multiframe carry another copy. Each copy of the SSM is sent MSB first and is aligned with the start of the sub-multiframe. ITU recommendation G.704 lists the SSM codes carried by E1 signals.

To extract SSMs from the incoming E1 data stream, the receive framer should be configured for CRC-4 multiframing (**BRCR3:RCRC4** = 1). Once in this mode, system software can read incoming SSMs from the appropriate **BRSaX** register (X = 4, 5, 6, 7, or 8) at any time. See Section 7.10.6.4. When an incoming SSM changes, the BITS receiver validates the new value according to the criteria specified in **BRMCR:SSMF**. When a new SSM is validated in one of the Sa-bit channels, the corresponding status bit is set in the **BRMSR** register, which can cause an interrupt if enabled by the corresponding interrupt enable bit in the **BRMIER** register. The most recently validated SSM message in an Sa-bit channel can be read by specifying the channel in **BRMCR:SSMCH** and reading the SSM message from the **BRSSM** register.

To insert SSMs into the outgoing E1 data stream, the transmit formatter should be configured for CRC-4 multiframing (**BTCR4:TCRC4** = 1), and the appropriate bit(s) in the **BTOCR** register should be set to enable the sourcing of the selected Sa bit(s) from the corresponding **BTSaX** register(s). See Section 7.10.6.4.

Figure 7-16. FAS/Si/RAI/Sa Source Logic

```

FAS bits
if BTCR4.TFPT=1 then source from TSER pin
  else source from BTAF register

Si bits, align frame
if BTOCR.SiAF=1 then source from BTSiAF register
  else if BTCR4:TCRC4=1 then source from CRC-4 generator
    else if BTCR4.TSiS=0 then source from TSER pin
      else if BTCR4.TFPT=1 then source from TSER pin
        else source from BTAF register

Si bits, non-align frame
if BTOCR.SiNAF=1 then source from BTSiNAF register
  else if BTCR4:TCRC4=1 then source from CRC-4 generator
    else if BTCR4.TSiS=0 then source from TSER pin
      else if BTCR4.TFPT=1 then source from TSER pin
        else source from BTNAF register

SaX bit (X=4, 5, 6, 7 or 8)
if BTOCR.SaX=1 then source from BTSaX register
  else if BTCR4.TFPT=1 then source from TSER pin
    else source from BTNAF register

```

7.10.7 G.703 2048kHz Synchronization Interface

The G.703 2048kHz synchronization interface is an unframed all-ones signal with specifications shown in Table 7-19. Figure 7-10 shows the external components required to operate the receiver and/or transmitter in this mode.

7.10.7.1 Receiver

The BITS receiver is configured for 2048kHz mode when **RMODE** = 10 in **BMCR**. The receiver line impedance must be configured for 75Ω or 120Ω by setting **BLCR3:RIMP[2:0]** = 00 or 11. The LIU receiver declares loss of signal (**BLIR1:LOS**) as described in Section 7.10.4.1.6.

7.10.7.2 Transmitter

The BITS transmitter is configured for 2048kHz mode when **BMCR:TMODE** = 10. In this mode, the transmitter line impedance must be configured for 75Ω or 120Ω by setting **BLCR2:TIMP[2:0]** = 00 or 11. In addition, the transmitter line build-out must be configured for 75Ω or 120Ω by setting **BLCR2:LBO[2:0]** = 000 or 001.

After configuring the transmitter for 2048kHz mode and 75Ω as described above, the following write sequence must be done to optimize the LIU transmitter:

```

write 01h to address 1FFh
write F8h to address 195h (BITS1) or 1A5h for (BITS2)
write 00h to address 199h (BITS1) or 1A9h (BITS2)
write 00h to address 1FFh

```

After configuring the transmitter for 2048kHz mode and 120Ω as described above, the following write sequence must be done to optimize the LIU transmitter:

```
write 01h to address 1FFh
write F8h to address 195h (BITS1) or 1A5h (BITS2)
write 09h to address 199h (BITS1) or 1A9h (BITS2)
write 00h to address 1FFh
```

When switching the BITS transmitter from 2048kHz to some other mode, the following write sequence must be done after writing **BMCR:TMODE#10**:

```
write 01h to address 1FFh
write 00h to address 195 h (BITS1) or 1A5h (BITS2)
write 00h to address 199h (BITS1) or 1A9h (BITS2)
write 00h to address 1FFh
```

Section 7.10.3 describes how to source the 2048kHz reference from the OCx output clocks. The output signal meets the template of G.703, shown in Figure 7-15. The nominal output amplitude is 1.2V typical for 75Ω LBO and 1.5V typical for 120Ω LBO.

Table 7-19. 2048kHz Synchronization Interface Specification

PARAMETER	COAX SPECIFICATION	TWISTED PAIR SPECIFICATION
Pulse Shape	Must conform with mask of G.703 Figure 20	
Transmission Media	Coaxial pair	Symmetrical pair
Test Load Impedance	75Ω resistive	120Ω resistive
Maximum Peak Voltage	1.5V	1.9V
Minimum Peak Voltage	0.75V	1.0V

7.10.8 G.703 Appendix II 6312kHz Japanese Synchronization Interface

The 6312kHz synchronization interface in G.703 Appendix II is a Japanese timing signal with the specifications shown in Table 7-20.

7.10.8.1 Receiver

The BITS receiver is configured for 6312kHz mode when RMODE = 11 in **BMCR**. The receiver line termination must be configured for 75Ω by setting RIMP[2:0] = 00 in **BLCR3**. The LIU receiver declares loss of signal (**BLIR1:LOS=1**) when the incoming signal level is below -24dBm. The receiver accepts both sine-wave and square-wave signals.

7.10.8.2 Transmitter

The BITS transmitter does not transmit the 6312 kHz signal because it is easily generated using any of output clocks OC1 through OC7 (square wave) and an external square-to-sinusoidal conversion network.

Table 7-20. 6312kHz Synchronization Interface Specification

PARAMETER	SPECIFICATION
Frequency	6312kHz
Signal Format	Sinusoidal wave
Transmission Medium	Coaxial cable
Load Impedance	75Ω resistive
Amplitude	0 ± 3 dBm
Alarm Condition for Received Signal Amplitude	No alarm for amplitudes between -16dBm and + 3dBm

7.11 Composite Clock Receivers and Transmitter

By default, input clocks IC1 and IC2 are configured as composite clock receivers. Output clock OC8 is a dedicated composite clock transmitter. These I/Os support the following composite clock variations:

- GR-378 composite clock (Note 1)
- G.703 centralized clock (Note 2)
- G.703 Japanese synchronization interface (Note 3)

Note 1: Complies with Telcordia GR-378 composite clock and G.703 Section 4.2.2 centralized clock option b).

Note 2: Complies with ITU_T G.703 Section 4.2.2 centralized clock options a) and G.703 Section 4.2.3 contradirectional interface clock.

Note 3: Complies with ITU_T G.703 Appendix II.1 options a) and option b) Japanese synchronization interfaces.

Composite clock (CC) signals provide both bit and byte synchronization for equipment with DS0 connections. In all CC variations, the signal is a 64kHz AMI signal with an embedded 8kHz clock indicated by a deliberate bipolar violation (BPV) every 8 clock cycles. The option b) Japanese synchronization interface in G.703 Appendix II.1 also has an embedded 400Hz clock indicated by a BPV *removed* every 400Hz. Details about the several composite clock variations are described in the following paragraphs and summarized in [Table 7-21](#).

GR-378 Composite Clock. As shown in [Table 7-22](#) and [Figure 7-17](#), the GR-378 composite clock signal has a 5/8 duty-cycle square pulse and a 133Ω line impedance. The G.703 Section 4.2.2 option b) centralized clock specifications are nearly identical to the GR-378 composite clock, with the exception of line termination impedance (110Ω for G.703 vs. 133Ω for GR-378).

G.703 Centralized Clock and other 64kHz + 8kHz Timing Signals. G.703 Section 4.2.2 defines two centralized clock types, option a) and option b). Option b) is discussed in the GR-378 paragraph above. As shown in [Table 7-23](#), the option a) centralized clock has a 50% duty cycle and a 110Ω line impedance. G.703 also specifies three other timing signals that have characteristics and specifications that are nearly identical to those of centralized clock option a). These other signals are (1) the timing signal in the 64kbps contradirectional interface defined in G.703 Section 4.2.3, (2) the 64kHz + 8kHz Japanese timing signal defined in G.703 Appendix II.1, and (3) the 64kHz + 8kHz + 400Hz Japanese timing signal defined in G.703 Appendix II.1 (which has the 8kHz BPV removed every 400Hz). [Table 7-23](#) tabulates the requirements for each of these signals.

Table 7-21. Composite Clock Variations

VARIATION	LINE IMPEDANCE (Ω)	PULSE AMPLITUDE (V)	NOMINAL DUTY CYCLE	BPVs
Composite Clock, GR-378	133	2.7 to 5.5	5/8	8kHz
Centralized Clock, G.703 4.2.2 option b)	110	3.0 ± 0.5	5/8	8kHz
Centralized Clock, G.703 4.2.2 option a)	110	1.0 ± 0.1V	50%	8kHz
Japanese Sync Interface, G.703 Appendix II.1 option a)	110	≤ 1 ± 0.1	50%	8kHz
Japanese Sync Interface, G.703 Appendix II.1 option b)	110	≤ 1 ± 0.1	50%	8kHz, but removed at 400Hz
Contradirectional Interface Clock, G.703 4.2.3	120	1.0 ± 0.1	50%	8kHz

7.11.1 IC1 and IC2 Receivers

Input clocks IC1 and IC2 can be either composite clock receivers (via the IC1A and IC2A pins) or standard CMOS/TTL inputs (via the IC1 and IC2 pins). Configuration bits `MCR5:IC1SF` and `IC2SF` specify the signal format for IC1 and IC2, respectively. When these inputs are configured as composite clock (CC) receivers, they can directly receive incoming AMI-coded 64kHz CC signals, including those with the pre-emphasis described in GR-378 Section 4.2. See the electrical specifications in [Table 10-6](#), and the recommended external components in [Figure 10-3](#). If IC1 and IC2 are not needed as composite clock inputs or CMOS/TTL inputs, another option is to connect the BITS receivers to these inputs (see [Section 7.10.2](#)).

Each CC receiver derives an 8kHz clock from the 8kHz component of the incoming CC signal. It is this 8kHz clock that is forwarded to the input clock monitoring and selection circuitry. The falling edge of this 8kHz clock can be configured to coincide with the leading edge of the 8kHz BPV or the leading edge of the pulse following the BPV, as specified by the `CCEDGE` field in the `MCR5` register.

Incoming composite clock signals are monitored for loss-of-signal and AMI violations. When either of these signal conditions occurs, a corresponding latched status bit is set in register `MSR3`. When set, these status bits can cause an interrupt request on the INTREQ pin if enabled by the corresponding bits in `IER3`. Loss of signal is declared when no pulses are detected in the incoming signal in a 32 μ s period (i.e., after two missing pulses, voltage threshold $V_{LOS} = 0.2V$ typical). The amplitude threshold for detecting a pulse is 0.2V. An AMI violation is declared when a deviation from the expected pattern of seven ones followed by a BPV occurs in each of two consecutive 8-bit periods. When `MCR5:BITERR = 1`, single-bit violations of the one-BPV-in-eight pattern are considered irregularities by the corresponding activity monitor and increment the leaky bucket accumulator. When `MCR5:AMI = 1`, the detection of an AMI violation automatically invalidates the offending clock. When `MCR5:LOS = 1`, the detection of loss-of-signal automatically invalidates the offending clock.

In addition, register `MSR4` has latched status bits that indicate the absence of the 8kHz component and the 400Hz component. In some networks the 8kHz component is removed to signal an alarm condition. If the BPVs that indicate the 8kHz component cannot be found in the incoming signal in a 500 μ s period (four 8kHz cycles), then `MSR4:ICxNO8` is set to indicate the fact. This can cause an interrupt on the INTREQ pin if enabled by the corresponding bit in `IER4`. This logic is always active. If the lack of the 8kHz component is not an alarm signal in the synchronization network, then `IER4:ICxNO8` can be set to 0 to disable the interrupt, and `MSR4:ICxNO8` can be ignored. If the 8kHz component is not present in the signal, then the CC receiver does not forward an 8kHz clock to the input monitoring logic. The input monitoring logic then declares that input clock invalid.

If the missing BPVs that indicate the 400Hz component cannot be found in a 5ms period (two 400Hz cycles), then `MSR4:ICxNO4` is set. This can cause an interrupt on the INTREQ pin if enabled by the corresponding bit in `IER4`. This logic is always active. If the 400Hz component is not expected to be present in the signal, then `IER4:ICxNO4` can be set to 0 to disable the interrupt, and `MSR4:ICxNO4` can be ignored.

When the 8kHz component is entirely missing from the incoming signal, the AMI status bit in `MSR3` is continually set, and can cause repeated interrupts if enabled. Therefore, in networks where the lack of the 8kHz component is used as an alarm signal, after `MSR4:ICxNO8` is set to indicate that the 8kHz component is missing, the interrupt for `MSR3:AMIX` should be disabled until `ICxNO8` goes low, indicating the 8kHz component is present again. Also, since the 8kHz component is the clock that is forwarded to the input clock monitor, if the 8kHz component is missing in the incoming signal, the input clock monitor automatically invalidates the clock. If the 400Hz component is missing, however, the AMI status bit is not set and the clock is not invalidated.

7.11.2 OC8 Transmitter

Output clock OC8 is a dedicated composite clock transmitter. See the recommended external components in [Figure 10-3](#). OC8 is a differential output consisting of pins OC8POS and OC8NEG. These pins are enabled/disabled by `OCR4:OC8EN`. Either 50% or 5/8 duty cycle can be selected by setting `T4CR1:OC8DUTY` appropriately. In some networks the 8kHz component (i.e., the one BPV every eight cycles) is removed to signal an alarm condition; the 8kHz component of the OC8 signal can be removed as needed by setting `MCR8:OC8NO8 = 1`.

When the selected reference is either IC1 or IC2 and that input is configured in AMI/CC mode (`MCR5:ICxSF = 0`), and the signal on that input has an 8kHz component (`MSR4:ICxNO8 = 0`), then the output BPVs on OC8 (the 8kHz component) are closely aligned (within a few μ s) to the input BPVs but may be of opposite polarity.

To support the G.703 Appendix II.1 option b) Japanese synchronization interface, the 400Hz component (i.e., the removed BPV every 160 cycles) can be enabled by setting `MCR8:OC8400 = 1`. If the selected reference is either IC1 or IC2 and that input is configured in AMI/CC mode (`MCR5:lcxSF = 0`) and the signal on that input has a 400 Hz component (`MSR4:ICxNO4 = 0`), then OC8's 400Hz component is aligned with the input 400 Hz component but may be the opposite polarity. Otherwise, the 400Hz component for OC8 is divided down from OC8's 8kHz component. Setting `OC8400 = 1` has no effect if `OC8NO8 = 1`. See Section 7.8.2.4 for additional OC8 configuration details.

Table 7-22. GR-378 Composite Clock Interface Specification

PARAMETER	SPECIFICATION
Nominal Line Rate	64kHz with 8kHz bipolar violation.
Line-Rate Accuracy	Accuracy of the network clock.
Line Code	Bipolar (AMI), return-to-zero, with 5/8 duty cycle.
Medium	A shielded, balanced twisted pair.
Test Load Impedance	The resistive test load of 133Ω ($\pm 5\%$) shall be used at the interface for evaluation of the pulse shape and the electrical parameters.
Pulse Amplitude	The amplitude of an isolated pulse shall be between 2.7V and 5.5V.
Pulse Shape	The shape of an isolated pulse shall be rectangular with rise and fall times less than 0.5μs such that the pulse fits the shape of the mask in Figure 7-17.
Pulse Imbalance	The ratio of the amplitudes of the positive and negative pulses shall be from 0.95 to 1.05. The ratio of the widths of the positive and negative pulses shall be from 0.95 to 1.05.
DC Power	No DC power shall be applied to the interface.

Figure 7-17. GR-378 Composite Clock Pulse Mask

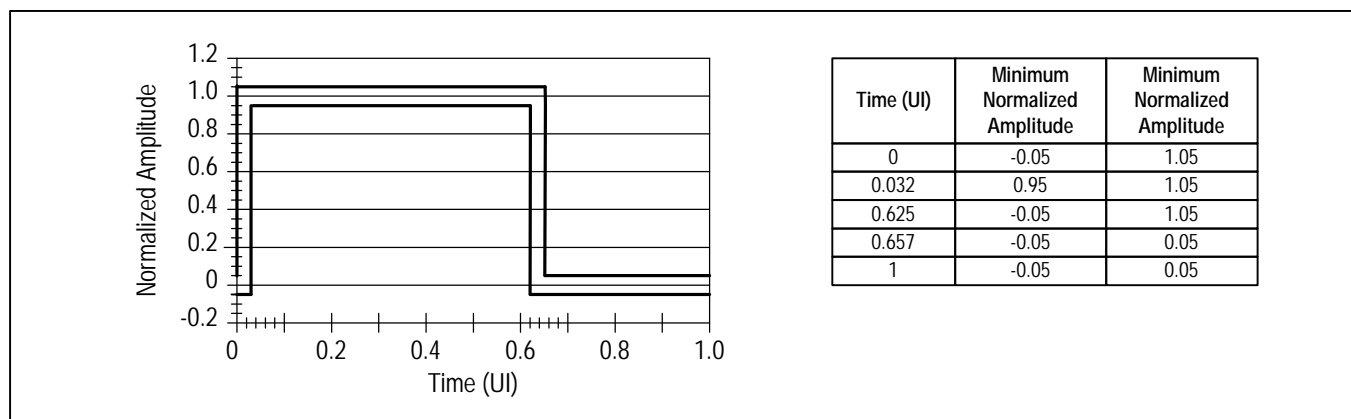

Table 7-23. G.703 Synchronization Interfaces Specification

PARAMETER	SPECIFICATION
Pulse Shape	Nominally rectangular, with rise and fall times less than 1μs.
Transmission Media	Symmetric pair cable.
Nominal Test Load Impedance	110Ω resistive (centralized clock and appendix II Japanese signals). 120Ω resistive (contradirectional interface).
Peak Voltage of a Mark (Pulse)	1.0V \pm 0.1V
Peak Voltage of a Space (No Pulse)	0V \pm 0.1V
Nominal Pulse Width	7.8μs \pm 0.78μs
Pulse Imbalance	The ratio of the amplitudes of the positive and negative pulses shall be from 0.95 to 1.05. The ratio of the widths of the positive and negative pulses shall be from 0.95 to 1.05.
Alarm Condition for Received Signal Amplitude	No alarm for pulse amplitudes between 0.63V _{0-P} and 1.1V _{0-P} .

7.12 Microprocessor Interfaces

The DS3100 microprocessor interface can be configured for 8-bit parallel or SPI serial operation. During reset, the device determines its interface mode by latching the state of the IFSEL[2:0] pins into the IFSEL field of the IFCR register. Table 7-24 shows possible values of IFSEL.

Table 7-24. Microprocessor Interface Modes

IFSEL[2:0]	MODE
010	Intel bus mode (multiplexed)
011	Intel bus mode (nonmultiplexed)
100	Motorola mode (nonmultiplexed)
101	SPI mode (LSB first)
110	Motorola mode (multiplexed)
111	SPI mode (MSB first)
000, 001	{unused value}

7.12.1 Parallel Interface Modes

In the Motorola interface modes, the interface is Motorola-style with \overline{CS} , $R\overline{W}$, and \overline{DS} control lines. In the Intel modes, the interface is Intel-style with \overline{CS} , \overline{RD} , and \overline{WR} control lines. For multiplexed bus modes, the A[8], AD[7:0], and ALE pins are wired to the corresponding pins on the microprocessor, and the falling edge of ALE latches the address on A[8] and AD[7:0]. For nonmultiplexed bus modes, the A[8:0] and AD[7:0] pins are wired to the corresponding pins on the micro, and the falling edge of ALE latches the address on A[8:0]. In nonmultiplexed bus modes, ALE is typically wired high to make the latch transparent. See Section 10.5 for AC timing details.

7.12.2 SPI Interface Mode

In the SPI modes, the device presents an SPI interface on the \overline{CS} , SCLK, SDI, and SDO pins. SPI is a widely used master/slave bus protocol that allows a master device and one or more slave devices to communicate over a serial bus. The DS3100 is always a slave device. Masters are typically microprocessors, ASICs, or FPGAs. Data transfers are always initiated by the master device, which also generates the SCLK signal. The DS3100 receives serial data on the SDI pin and transmits serial data on the SDO pin. SDO is high impedance except when the DS3100 is transmitting data to the bus master.

Bit Order. When IFCR:IFSEL = 101, the register address and all data bytes are transmitted LSB first on both SDI and SDO. When IFSEL = 111, the register address and all data bytes are transmitted MSB first on both SDI and SDO. The Motorola SPI convention is MSB first.

Clock Polarity and Phase. The CPOL pin defines the polarity of SCLK. When CPOL = 0, SCLK is normally low and pulses high during bus transactions. When CPOL = 1, SCLK is normally high and pulses low during bus transactions. The CPHA pin sets the phase (active edge) of SCLK. When CPHA = 0, data is latched in on SDI on the leading edge of the SCLK pulse and updated on SDO on the trailing edge. When CPHA = 1, data is latched in on SDI on the trailing edge of the SCLK pulse and updated on SDO on the following leading edge. SCLK does not have to toggle between access, i.e., when \overline{CS} is high. See Figure 7-18.

Device Selection. Each SPI device has its own chip-select line. To select the DS3100, pull its \overline{CS} pin low.

Control Word. After \overline{CS} is pulled low, the bus master transmits the control word during the first 16 SCLK cycles. In MSB-first mode, the control word has the form:

$$R\overline{W} \ A_{13} \ A_{12} \ A_{11} \ A_{10} \ A_9 \ A_8 \ A_7 \ \ A_6 \ A_5 \ A_4 \ A_3 \ A_2 \ A_1 \ A_0 \ \text{BURST}$$

where A[13:0] is the register address, $R\overline{W}$ is the data direction bit (1 = read, 0 = write), and BURST is the burst bit (1 = burst access, 0 = single-byte access). In LSB-first mode, the order of the 14 address bits is reversed. In the discussion that follows, a control word with $R\overline{W} = 1$ is a read control word, while a control word with $R\overline{W} = 0$ is a write control word.

Single-Byte Writes. See Figure 7-19. After \overline{CS} goes low, the bus master transmits a write control word with BURST = 0 followed by the data byte to be written. The bus master then terminates the transaction by pulling \overline{CS} high.

Single-Byte Reads. See Figure 7-19. After \overline{CS} goes low, the bus master transmits a read control word with BURST = 0. The DS3100 then responds with the requested data byte. The bus master then terminates the transaction by pulling \overline{CS} high.

Burst Writes. See Figure 7-19. After \overline{CS} goes low, the bus master transmits a write control word with BURST = 1 followed by the first data byte to be written. The DS3100 receives the first data byte on SDI, writes it to the specified register, increments its internal address register, and prepares to receive the next data byte. If the master continues to transmit, the DS3100 continues to write the data received and increment its address counter. After the address counter reaches 3FFFh, it rolls over to address 0000h and continues to increment.

Burst Reads. See Figure 7-19. After \overline{CS} goes low, the bus master transmits a read control word with BURST = 1. The DS3100 then responds with the requested data byte on SDO, increments its address counter, and prefetches the next data byte. If the bus master continues to demand data, the DS3100 continues to provide the data on SDO, increment its address counter, and prefetch the following byte. After the address counter reaches 3FFFh, it rolls over to address 0000h and continues to increment.

Early Termination of Bus Transactions. The bus master can terminate SPI bus transactions at any time by pulling \overline{CS} high. In response to early terminations, the DS3100 resets its SPI interface logic and waits for the start of the next transaction. If a write transaction is terminated prior to the SCLK edge that latches the LSB of a data byte, the data byte is not written.

Design Option: Wiring SDI and SDO Together. Because communication between the bus master and the DS3100 is half-duplex, the SDI and SDO pins can be wired together externally to reduce wire count. To support this option, the bus master must not drive the SDI/SDO line when the DS3100 is transmitting.

AC Timing. See Table 10-14 and Figure 10-8 for AC timing specifications for the SPI interface.

Figure 7-18. SPI Clock Polarity and Phase Options

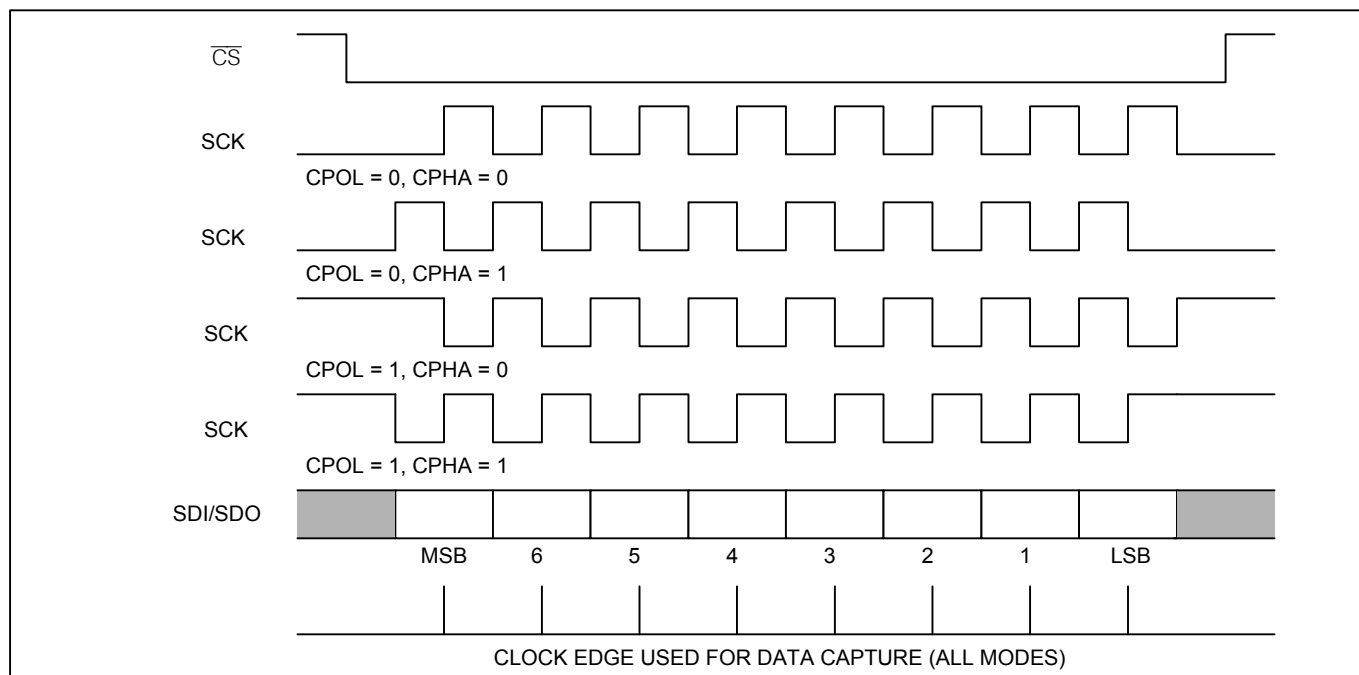
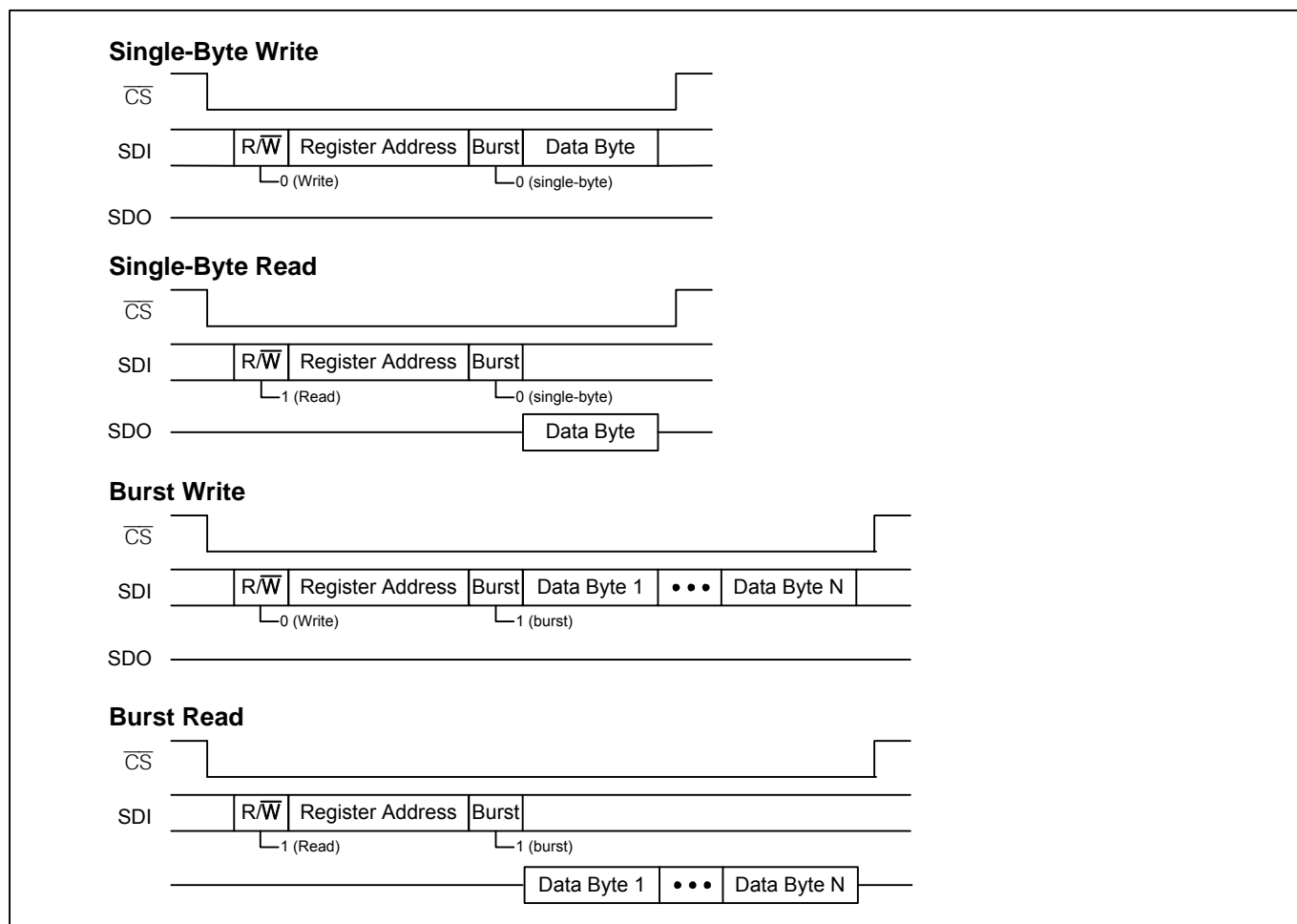

Figure 7-19. SPI Bus Transactions



7.13 Reset Logic

The device has three reset controls: the \overline{RST} pin, the RST bit in **MCR1**, and the JTAG reset pin, \overline{JTRST} . The \overline{RST} pin asynchronously resets the entire device, except for the JTAG logic. When the \overline{RST} pin is low, all internal registers are reset to their default values, including those fields that latch their default values from, or based on, the states of input pins when the \overline{RST} pin goes high (such as **IFCR:IFSEL[2:0]**). **The \overline{RST} pin must be asserted once after power-up while the external oscillator is stabilizing.**

The **MCR1:RST** bit resets the entire device (except for the microprocessor interface, the JTAG logic, and the RST bit itself), but when RST is active, the register fields with pin-programmed defaults do not latch their values from, or based on, the corresponding input pins. Instead, these fields are reset to the default values that were latched when the \overline{RST} pin was last active.

Systems should hold \overline{RST} low while the external oscillator starts up and stabilizes. Some OCXOs take 250ms or more to start up and stabilize their output signals to valid logic levels and pulse widths. An incorrect reset condition could result if \overline{RST} is released before the oscillator has started up completely.

Important: System software must wait at least 100 μ s after reset (\overline{RST} pin or RST bit) is deasserted before initializing the device as described in Section 7.15.

7.14 Power-Supply Considerations

Due to the dual-power-supply nature of the DS3100, some I/Os have parasitic diodes between a 1.8V supply and a 3.3V supply. When ramping power supplies up or down, care must be taken to avoid forward-biasing these diodes because it could cause latchup. Two methods are available to prevent this. The first method is to place a Schottky diode external to the device between the 1.8V supply and the 3.3V supply to force the 3.3V supply to be less than one parasitic diode drop below the 1.8V supply. The second method is to ramp up the 3.3V supply first and then ramp up the 1.8V supply.

7.15 Initialization

After power-up or reset, a series of writes must be done to the DS3100 to tune it for optimal performance. This series of writes is called the initialization script. Each die revision of the DS3100 has a different initialization script. Download the latest initialization scripts from the DS3100 website at www.maxim-ic.com/DS3100.

8. REGISTER DESCRIPTIONS

The top-level memory map is shown in [Table 8-1](#). In addition to the registers for the core timing block, the memory map also includes space for the two identical BITS transceivers, BITS1 and BITS2.

Table 8-1. Top-Level Memory Map

ADDRESS RANGE	FUNCTIONAL BLOCK
0000–007Fh	Core PLL Block
0080–00FFh	BITS Transceiver 1 (BITS1)
0100–017Fh	BITS Transceiver 2 (BITS2)
0180–01FFh	Reserved

Note: Systems must be able to access the entire address range from 0 to 01FFh. Proper device initialization requires a sequence of writes to addresses in the range 0180-01FFh.

[Table 8-2](#) in [Section 8.4](#) shows the register map for the core timing block, while [Table 8-3](#) in [Section 8.5](#) shows the register map for the BITS transceivers. In each register, bit 7 is the MSB and bit 0 is the LSB. Register addresses not listed and bits marked “—” are reserved and must be written with 0. Writing other values to these registers may put the device in a factory test mode, resulting in undefined operation. Bits labeled “0” or “1” must be written with that value for proper operation. Register fields with underlined names are read-only fields; writes to these fields have no effect. All other fields are read-write. Register fields are described in detail in the register descriptions that follow [Table 8-2](#).

8.1 Status Bits

The device has two types of status bits. Real-time status bits are read-only and indicate the state of a signal at the time it is read. Latched status bits are set when a signal changes state (low-to-high, high-to-low, or both, depending on the bit) and cleared when written with a logic 1 value. Writing a 0 has no effect. When set, some latched status bits can cause an interrupt request on the INTREQ pin if enabled to do so by corresponding interrupt enable bits.

8.2 Configuration Fields

Configuration fields are read-write. During reset, each configuration field reverts to the default value shown in the register definition. Configuration register bits marked “—” are reserved and must be written with 0.

8.3 Multiregister Fields

Multiregister fields—such as `FREQ[18:0]` in registers [FREQ1](#), [FREQ2](#), and [FREQ3](#)—must be handled carefully to ensure that the bytes of the field remain consistent. A write access to a multiregister field is accomplished by writing all the registers of the field in any order, with no other accesses to the device in between. If the write sequence is interrupted by another access, none of the bytes are written and the `MSR4:MRAA` bit is set to indicate the write was aborted. A read access from a multiregister field is accomplished by reading the registers of the field in any order, with no other accesses to the device in between. When one register of a multiregister field is read, the other register(s) in the field are frozen until after they are all read. If the read sequence is interrupted by another access, the registers of the multibyte field are unfrozen and the `MSR4:MRAA` bit is set to indicate the read was aborted. For best results, interrupt servicing should be disabled in the microprocessor before a multiregister access and then enabled again after the access is complete. The multiregister fields are:

FIELD	REGISTERS	ADDRESSES	TYPE
<code>FREQ[18:0]</code>	FREQ1 , FREQ2 , FREQ3	07, 0C, 0D	read-only
<code>MCLKFREQ[15:0]</code>	MCLK1 , MCLK2	3C, 3D	read/write
<code>HOFREQ[18:0]</code>	HOCR1 , HOCR2 , HOCR3*	3E, 3F, 40	read/write
<code>HARDLIM[9:0]</code>	DLIMIT1 , DLIMIT2	41, 42	read/write
<code>DIVN[14:0]</code>	DIVN1 , DIVN2	46, 47	read/write
<code>OFFSET[15:0]</code>	OFFSET1 , OFFSET2	70, 71	read/write
<code>PHASE[15:0]</code>	PHASE1 , PHASE2	77, 78	read-only

*[HOCR3](#) is a special case because its upper 5 bits are not part of a multiregister field, but its lower 3 bits are part of the `HOFREQ[18:0]` multiregister field. Writes to [HOCR3](#) immediately update the upper 5 bits without any requirement to also write [HOCR1](#) and [HOCR2](#). The lower 3 bits of [HOCR3](#) (`HOFREQ[18:16]`), however, can only be written as part of a proper write sequence for a multiregister field, as described above. A write to [HOCR3](#) contiguous with writes to [HOCR1](#) and [HOCR2](#) can simultaneously write the upper 5 bits immediately and start/continue/complete a multiregister write of `HOFREQ[18:0]`.

8.4 Core Register Definitions

Table 8-2. Core Register Map

Note: Register names are hyperlinks to register definitions. Underlined> fields are read-only.

ADDR	REGISTER	BIT 7	BIT 6	BIT 5	BIT 4	BIT 3	BIT 2	BIT 1	BIT 0
00h	ID1	ID[7:0]							
01	ID2	ID[15:8]							
02	REV	REV[7:0]							
03	TEST1	PALARM	D180	—	RA	0	8KPOL	0	0
05	MSR1	IC8	IC7	IC6	IC5	IC4	IC3	IC2	IC1
06	MSR2	STATE	SRFAIL	IC14	IC13	IC12	IC11	IC10	IC9
07	FREQ3	—	—	—	—	—	FREQ[18:16]		
08	MSR3	FSMON	T4LOCK	PHMON	T4NOIN	AMI2	LOS2	AMI1	LOS1
09	OPSTATE	FSMON	T4LOCK	T0SOFT	T4SOFT	—	T0STATE[2:0]		
0A	PTAB1	REF1[3:0]				SELREF[3:0]			
0B	PTAB2	REF3[3:0]				REF2[3:0]			
0C	FREQ1	FREQ[7:0]							
0D	FREQ2	FREQ[15:8]							
0E	VALSR1	IC8	IC7	IC6	IC5	IC4	IC3	IC2	IC1
0F	VALSR2	FHORDY	SHORDY	IC14	IC13	IC12	IC11	IC10	IC9
10	ISR1	SOFT2	HARD2	ACT2	LOCK2	SOFT1	HARD1	ACT1	LOCK1
11	ISR2	SOFT4	HARD4	ACT4	LOCK4	SOFT3	HARD3	ACT3	LOCK3
12	ISR3	SOFT6	HARD6	ACT6	LOCK6	SOFT5	HARD5	ACT5	LOCK5
13	ISR4	SOFT8	HARD8	ACT8	LOCK8	SOFT7	HARD7	ACT7	LOCK7
14	ISR5	SOFT10	HARD10	ACT10	LOCK10	SOFT9	HARD9	ACT9	LOCK9
15	ISR6	SOFT12	HARD12	ACT12	LOCK12	SOFT11	HARD11	ACT11	LOCK11
16	ISR7	SOFT14	HARD14	ACT14	LOCK14	SOFT13	HARD13	ACT13	LOCK13
17	MSR4	FHORDY	SHORDY	MRAA	—	IC2NO4	IC1NO4	IC2NO8	IC1NO8
18	IPR1	PRI2[3:0]				PRI1[3:0]			
19	IPR2	PRI4[3:0]				PRI3[3:0]			
1A	IPR3	PRI6[3:0]				PRI5[3:0]			
1B	IPR4	PRI8[3:0]				PRI7[3:0]			
1C	IPR5	PRI10[3:0]				PRI9[3:0]			
1D	IPR6	PRI12[3:0]				PRI11[3:0]			
1E	IPR7	PRI14[3:0]				PRI13[3:0]			
20	ICR1	DIVN	LOCK8K	BUCKET[1:0]		FREQ[3:0]			
21	ICR2	DIVN	LOCK8K	BUCKET[1:0]		FREQ[3:0]			
22	ICR3	DIVN	LOCK8K	BUCKET[1:0]		FREQ[3:0]			
23	ICR4	DIVN	LOCK8K	BUCKET[1:0]		FREQ[3:0]			
24	ICR5	DIVN	LOCK8K	BUCKET[1:0]		FREQ[3:0]			
25	ICR6	DIVN	LOCK8K	BUCKET[1:0]		FREQ[3:0]			
26	ICR7	DIVN	LOCK8K	BUCKET[1:0]		FREQ[3:0]			
27	ICR8	DIVN	LOCK8K	BUCKET[1:0]		FREQ[3:0]			
28	ICR9	DIVN	LOCK8K	BUCKET[1:0]		FREQ[3:0]			
29	ICR10	DIVN	LOCK8K	BUCKET[1:0]		FREQ[3:0]			
2A	ICR11	DIVN	LOCK8K	BUCKET[1:0]		FREQ[3:0]			
2B	ICR12	DIVN	LOCK8K	BUCKET[1:0]		FREQ[3:0]			
2C	ICR13	DIVN	LOCK8K	BUCKET[1:0]		FREQ[3:0]			
2D	ICR14	DIVN	LOCK8K	BUCKET[1:0]		FREQ[3:0]			
30	VALCR1	IC8	IC7	IC6	IC5	IC4	IC3	IC2	IC1
31	VALCR2	—	—	IC14	IC13	IC12	IC11	IC10	IC9
32	MCR1	RST	—	—	—	—	T0STATE[2:0]		
33	MCR2	—	—	—	—	T0FORCE[3:0]			
34	MCR3	AEFSEN	LKATO	XOEDGE	MANHO	EFSEN	SONSDH	MASTSLV	REVERT

ADDR	REGISTER	BIT 7	BIT 6	BIT 5	BIT 4	BIT 3	BIT 2	BIT 1	BIT 0
35	MCR4	LKT4T0	T4DFB	—	OC89	T4FORCE[3:0]			
36	MCR5	CCEDGE	BITERR	AMI	LOS	IC2SF	IC1SF	IC6SF	IC5SF
37	IFSR	—	—	—	—	—	IFSEL[2:0]		
38	MCR6	DIG2AF	DIG2SS	DIG1SS	—	—	—	—	—
39	MCR7	DIG2F[1:0]		DIG1F[1:0]		—	—	—	—
3A	MCR8	—	—	OC8400	OC8NO8	OC7SF		OC6SF	
3B	MCR9	AUTOBW	—	—	—	LIMINT	PFD180	—	—
3C	MCLK1	MCLKFREQ[7:0]							
3D	MCLK2	MCLKFREQ[15:8]							
3E	HOCR1	HOFREQ[7:0]							
3F	HOCR2	HOFREQ[15:8]							
40	HOCR3	AVG	FAST	RDAVG	MINIHO[1:0]		HOFREQ[18:16]		
41	DLIMIT1	HARDLIM[7:0]							
42	DLIMIT2	—	—	—	—	—	—	HARDLIM[9:8]	
43	IER1	IC8	IC7	IC6	IC5	IC4	IC3	IC2	IC1
44	IER2	STATE	SRFAIL	IC14	IC13	IC12	IC11	IC10	IC9
45	IER3	FSMON	T4LOCK	PHMON	T4NOIN	AMI2	LOS2	AMI1	LOS1
46	DIVN1	DIVN[7:0]							
47	DIVN2	—	DIVN[14:8]						
48	MCR10	FMONCLK	SRFPIN	UFSW	EXTSW	PBOFRZ	PBOEN	SOFTEN	HARDEN
49	ILIMIT	SOFT[3:0]				HARD[3:0]			
4A	SRLIMIT	SOFT[3:0]				HARD[3:0]			
4B	MCR11	—	—	—	T4T0	FMEASIN[3:0]			
4C	FMEAS	FMEAS[7:0]							
4D	DLIMIT3	FLLOL	SOFTLIM[6:0]						
4E	IER4	FHORDY	SHORDY	—	—	IC2NO4	IC1NO4	IC2NO8	IC1NO8
50	LB0U	LB0U[7:0]							
51	LB0L	LB0L[7:0]							
52	LB0S	LB0S[7:0]							
53	LB0D	—	—	—	—	—	—	LB0D[1:0]	
54	LB1U	LB1U[7:0]							
55	LB1L	LB1L[7:0]							
56	LB1S	LB1S[7:0]							
57	LB1D	—	—	—	—	—	—	LB1D[1:0]	
58	LB2U	LB2U[7:0]							
59	LB2L	LB2L[7:0]							
5A	LB2S	LB2S[7:0]							
5B	LB2D	—	—	—	—	—	—	LB2D[1:0]	
5C	LB3U	LB3U[7:0]							
5D	LB3L	LB3L[7:0]							
5E	LB3S	LB3S[7:0]							
5F	LB3D	—	—	—	—	—	—	LB3D[1:0]	
60	OCR1	OFREQ2[3:0]				OFREQ1[3:0]			
61	OCR2	OFREQ4[3:0]				OFREQ3[3:0]			
62	OCR3	OFREQ6[3:0]				OFREQ5[3:0]			
63	OCR4	OC11EN	OC10EN	OC9EN	OC8EN	OFREQ7[3:0]			
64	T4CR1	—	ASQUEL	OC8DUTY	OC9SON	T4FREQ[3:0]			
65	T0CR1	T4MT0	T4APT0	T0FT4[2:0]		T0FREQ[2:0]			
66	T4BW	—	—	—	—	—	—	T4BW[1:0]	
67	T0LBW	—	—	—	T0LBW[4:0]				
69	T0ABW	—	—	—	T0ABW[4:0]				
6A	T4CR2	—	PD2GA8K[2:0]			—	DAMP[2:0]		
6B	T0CR2	—	PD2GA8K[2:0]			—	DAMP[2:0]		
6C	T4CR3	PD2EN	PD2GA[2:0]			—	PD2GD[2:0]		
6D	T0CR3	PD2EN	PD2GA[2:0]			—	PD2GD[2:0]		

ADDR	REGISTER	BIT 7	BIT 6	BIT 5	BIT 4	BIT 3	BIT 2	BIT 1	BIT 0
6E	GPCR	GPIO4D	GPIO3D	GPIO2D	GPIO1D	GPIO40	GPIO30	GPIO20	GPIO10
6F	GPSR	—	—	—	—	GPIO4	GPIO3	GPIO2	GPIO1
70	OFFSET1	OFFSET[7:0]							
71	OFFSET2	OFFSET[15:8]							
72	PBOFF	—	—	PBOFF[5:0]					
73	PHLIM1	FLEN	NALOL	1	—	—	FINELIM[2:0]		
74	PHLIM2	CLEN	MCPDEN	USEMCPD	—	COARSELIM[3:0]			
76	PHMON	NW	—	PMEN	PMPBEN	PMLIM[3:0]			
77	PHASE1	PHASE[7:0]							
78	PHASE2	PHASE[15:8]							
79	PHLKTO	PHLKTOM[1:0]		PHLKTO[5:0]					
7A	FSCR1	2K8KSRC	—	—	—	8KINV	8KPUL	2KINV	2KPUL
7B	FSCR2	INDEP	OCN	—	—	—	—	PHASE[1:0]	
7C	FSCR3	RECAL	MONLIM[2:0]			SOURCE[3:0]			
7D	INTCR	—	—	—	—	—	GPO	OD	POL
7E	PROT	PROT[7:0]							
7F	IFCR	—	—	—	—	—	IFSEL[2:0]		

Core Register Map Color Coding

	Device Identification and Protection
	Local Oscillator and Master Clock Configuration
	Input Clock Configuration
	Input Clock Monitoring
	Input Clock Selection
	DPLL Configuration
	DPLL State
	Output Clock Configuration
	SYNC2K Configuration
	Microprocessor Interface Configuration

Unused Core Register Addresses

04h, 1Fh, 2Eh, 2Fh, 4Fh, 68h, 75h

Register Name: ID1
Register Description: Device Identification Register, LSB
Register Address: 00h

	Bit 7	Bit 6	Bit 5	Bit 4	Bit 3	Bit 2	Bit 1	Bit 0
Name	ID[7:0]							
Default	0	0	0	1	1	1	0	0

Bits 7 to 0: Device ID (ID[7:0]). ID[15:0] = 0C1Ch = 3100 decimal.

Register Name: ID2
Register Description: Device Identification Register, MSB
Register Address: 01h

	Bit 7	Bit 6	Bit 5	Bit 4	Bit 3	Bit 2	Bit 1	Bit 0
Name	ID[15:8]							
Default	0	0	0	0	1	1	0	0

Bits 7 to 0: Device ID (ID[15:8]). See the [ID1](#) register description.

Register Name: REV
Register Description: Device Revision Register
Register Address: 02h

	Bit 7	Bit 6	Bit 5	Bit 4	Bit 3	Bit 2	Bit 1	Bit 0
Name	REV[7:0]							
Default	0	0	0	0	0	0	0	0

Bits 7 to 0: Device Revision (REV[7:0]). Contact the factory to interpret this value and determine the latest revision.

Register Name: TEST1
Register Description: Test Register 1 (Not Normally Used)
Register Address: 03h

	Bit 7	Bit 6	Bit 5	Bit 4	Bit 3	Bit 2	Bit 1	Bit 0
Name	PALARM	D180	—	RA	0	8KPOL	0	0
Default	0	0	0	1	0	1	0	0

Bit 7: Phase Alarm (PALARM). This real-time status bit indicates the state of T0 DPLL phase lock.

0 = T0 phase-locked to input reference

1 = T0 loss of phase lock

Bit 6: Disable 180 (D180). When locking to a new reference, the T0 DPLL first tries nearest-edge locking ($\pm 180^\circ$) for the first two seconds. If unsuccessful it then tries full phase/frequency locking ($\pm 360^\circ$). Disabling the nearest-edge locking can reduce lock time by up to two seconds but may cause an unnecessary phase shift (up to 360°) when the new reference is close in frequency/phase to the old reference. See Section 7.7.5.

0 = normal operation: try nearest-edge locking then phase/frequency locking

1 = phase/frequency locking only

Bit 4: Resync Analog Dividers (RA). When this bit is set the T0 APLL output dividers are always synchronized to ensure that low-frequency outputs are in sync with the higher-frequency clock from the T0 DPLL.

0 = not synchronized

1 = always synchronized

Bit 3: Leave set to zero (test control).

Bit 2: 8kHz Edge Polarity (8KPOL). Specifies the input clock edge to lock to on the selected reference when it is configured for LOCK8K mode. See Section 7.4.2.

0 = Falling edge

1 = Rising edge

Bit 1: Leave set to zero (test control).

Bit 0: Leave set to zero (test control).

Register Name: MSR1
Register Description: Master Status Register 1
Register Address: 05h

	Bit 7	Bit 6	Bit 5	Bit 4	Bit 3	Bit 2	Bit 1	Bit 0
Name	IC8	IC7	IC6	IC5	IC4	IC3	IC2	IC1
Default	1	1	1	1	1	1	1	1

Bits 7 to 0: Input Clock Status Change (IC8 to IC1). Each of these latched status bits is set to 1 when the corresponding [VALSR1](#) status bit changes state (set or cleared). If soft frequency limit alarms are enabled ([MCR10:SOFTEN](#) = 1), then each of these latched status bits is also set to 1 when the corresponding SOFT bit in the [ISR](#) registers changes state (set or cleared). Each bit is cleared when written with a 1 and not set again until either the [VALSR1](#) bit or the SOFT bit changes state again. When one of these latched status bits is set it can cause an interrupt request on the INTREQ pin if the corresponding interrupt enable bit is set in the [IER1](#) register. See Section 7.5 for input clock validation/invalidation criteria.

Register Name: MSR2
Register Description: Master Status Register 2
Register Address: 06h

	Bit 7	Bit 6	Bit 5	Bit 4	Bit 3	Bit 2	Bit 1	Bit 0
Name	STATE	SRFAIL	IC14	IC13	IC12	IC11	IC10	IC9
Default	0	0	1	1	1	1	1	1

Bit 7: T0 DPLL State Change (STATE). This latched status bit is set to 1 when the operating state of the T0 DPLL changes. STATE is cleared when written with a 1 and not set again until the operating state changes again. When STATE is set it can cause an interrupt request on the INTREQ pin if the STATE interrupt enable bit is set in the [IER2](#) register. The current operating state can be read from the T0STATE field of the [OPSTATE](#) register. See Section 7.7.1.

Bit 6: Selected Reference Failed (SRFAIL). This latched status bit is set to 1 when the selected reference to the T0 DPLL fails (i.e., no clock edges in two UI). SRFAIL is cleared when written with a 1. When SRFAIL is set it can cause an interrupt request on the INTREQ pin if the SRFAIL interrupt enable bit is set in the [IER2](#) register. SRFAIL is not set in free-run mode or holdover mode. See Section 7.5.3.

Bits 5 to 0: Input Clock Status Change (IC14 to IC9). Each of these latched status bits is set to 1 when the corresponding [VALSR](#) status bit changes state (set or cleared). If soft frequency limit alarms are enabled ([MCR10:SOFTEN](#) = 1), then each of these latched status bits is also set to 1 when the corresponding SOFT bit in the [ISR](#) registers changes state (set or cleared). Each bit is cleared when written with a 1 and not set again until either the [VALSR](#) bit or the SOFT bit changes state again. When one of these latched status bits is set it can cause an interrupt request on the INTREQ pin if the corresponding interrupt enable bit is set in the [IER2](#) register. See Section 7.5 for input clock validation/invalidation criteria.

Register Name: [FREQ3](#)
Register Description: Frequency Register 3
Register Address: 07h

	Bit 7	Bit 6	Bit 5	Bit 4	Bit 3	Bit 2	Bit 1	Bit 0
Name	—	—	—	—	—	FREQ[18:16]		
Default	0	0	0	0	0	0	0	0

Bits 2 to 0: Current DPLL Frequency (FREQ[18:16]). See the [FREQ1](#) register description.

Register Name: MSR3
Register Description: Master Status Register 3
Register Address: 08h

	Bit 7	Bit 6	Bit 5	Bit 4	Bit 3	Bit 2	Bit 1	Bit 0
Name	FSMON	T4LOCK	PHMON	T4NOIN	AMI2	LOS2	AMI1	LOS1
Default	0	1	0	1	0	0	0	0

Bit 7: Frame Sync Input Monitor Alarm (FSMON). This latched status bit is set to 1 when `OPSTATE:FSMON` transitions from 0 to 1. FSMON is cleared when written with a 1. When FSMON is set it can cause an interrupt request on the INTREQ pin if the FSMON interrupt enable bit is set in the `IER3` register. See Section 7.9.3.

Bit 6: T4 DPLL Lock Status Change (T4LOCK). This latched status bit is set to 1 when the lock status of the T4 DPLL (`OPSTATE:T4LOCK`) changes (becomes locked when previously unlocked or becomes unlocked when previously locked). T4LOCK is cleared when written with a 1 and not set again until the T4 lock status changes again. When T4LOCK is set it can cause an interrupt request on the INTREQ pin if the T4LOCK interrupt enable bit is set in the `IER3` register. See Section 7.7.6.

Bit 5: Phase Monitor Alarm (PHMON). This latched status bit is set to 1 when the phase monitor alarm limit has been exceeded (PMLIM field of the `PHMON` register). PHMON is cleared when written with a 1 and not set again until the threshold is exceeded again. When PHMON is set it can cause an interrupt request on the INTREQ pin if the PHMON interrupt enable bit is set in the `IER3` register. See Section 7.7.7.

Bit 4: T4 No Valid Inputs Alarm (T4NOIN). This latched status bit is set to 1 when the T4 DPLL has no valid inputs available. T4NOIN is cleared when written with a 1 unless the T4 DPLL still has no valid inputs available. When T4NOIN is set it can cause an interrupt request on the INTREQ pin if the T4NOIN interrupt enable bit is set in the `IER3` register. See Section 7.5.

Bit 3: AMI Violation on IC2 (AMI2). This latched status bit is set to 1 when a deviation from the expected pattern of seven ones followed by a BPV occurs on the IC2 input in each of two consecutive 8-bit periods. However, if the composite clock receiver can detect the presence of the 400 Hz component required by G.703 Appendix II.1 option b), then the missing BPVs that indicate the 400 Hz component are not considered AMI violations. AMI2 is cleared when written with a 1 and not set again until another AMI violation occurs. When AMI2 is set it can cause an interrupt request on the INTREQ pin if the AMI2 interrupt enable bit is set in the `IER3` register. This status bit is only enabled when IC2 is configured as a composite clock receiver (`MCR5:IC2SF = 0`). See Section 7.11.1.

Bit 2: LOS Error on IC2 (LOS2). This latched status bit is set to 1 when no pulses are detected on the IC2 input in a 32 μ s period (i.e., after two missing pulses). LOS2 is cleared when written with a 1 and is not set again until IC2 transitions from valid signal to loss-of-signal again. When LOS2 is set it can cause an interrupt request on the INTREQ pin if the LOS2 interrupt enable bit is set in the `IER3` register. This status bit is only enabled when IC2 is configured as a composite clock receiver (`MCR5:IC2SF = 0`). See Section 7.11.1.

Bit 1: AMI Violation on IC1 (AMI1). This latched status bit is set to 1 when a deviation from the expected pattern of seven ones followed by a BPV occurs on the IC1 input in each of two consecutive 8-bit periods. However, if the composite clock receiver can detect the presence of the 400Hz component required by G.703 Appendix II.1 option b), then the missing BPVs that indicate the 400Hz component are not considered AMI violations. AMI1 is cleared when written with a 1 and not set again until another AMI violation occurs. When AMI1 is set it can cause an interrupt request on the INTREQ pin if the AMI1 interrupt enable bit is set in the `IER3` register. This status bit is only enabled when IC1 is configured as a composite clock receiver (`MCR5:IC1SF = 0`). See Section 7.11.1.

Bit 0: LOS Error on IC1 (LOS1). This latched status bit is set to 1 when no pulses are detected on the IC1 input in a 32 μ s period (i.e., after two missing pulses). LOS1 is cleared when written with a 1 and is not set again until IC1 transitions from valid signal to loss-of-signal again. When LOS1 is set it can cause an interrupt request on the INTREQ pin if the LOS1 interrupt enable bit is set in the `IER3` register. This status bit is only enabled when IC1 is configured as a composite clock receiver (`MCR5:IC1SF = 0`). See Section 7.11.1.

Register Name: OPSTATE
Register Description: Operating State Register
Register Address: 09h

	Bit 7	Bit 6	Bit 5	Bit 4	Bit 3	Bit 2	Bit 1	Bit 0
Name	<u>FSMON</u>	<u>T4LOCK</u>	<u>T0SOFT</u>	<u>T4SOFT</u>	—	<u>T0STATE[2:0]</u>		
Default	0	1	0	0	0	0	0	1

Bit 7: Frame Sync Input Monitor Alarm (FSMON). This real-time status bit indicates the current status of the frame sync input monitor. See Section 7.9.3.

- 0 = no alarm
- 1 = alarm

Bit 6: T4 DPLL Lock Status (T4LOCK). This real-time status bit indicates the current phase lock status of the T4 DPLL. See Sections 7.5.3 and 7.7.6.

- 0 = not locked to selected reference
- 1 = locked to selected reference

Bit 5: T0 DPLL Frequency Soft Alarm (T0SOFT). This real-time status bit indicates whether or not the T0 DPLL is tracking its reference within the soft alarm limits specified in the SOFT[6:0] field of the DLIMIT3 register. See Section 7.7.6.

- 0 = No alarm; frequency is within the soft alarm limits
- 1 = Soft alarm; frequency is outside the soft alarm limits

Bit 4: T4 DPLL Frequency Soft Alarm (T4SOFT). This real-time status bit indicates whether or not the T4 DPLL is tracking its reference within the soft alarm limits specified in the SOFT[6:0] field of the DLIMIT3 register. See Section 7.7.6.

- 0 = No alarm; frequency is within the soft alarm limits
- 1 = Soft alarm; frequency is outside the soft alarm limits

Bits 2 to 0: T0 DPLL Operating State (T0STATE[2:0]). This real-time status field indicates the current state of the T0 DPLL state machine. Values not listed below correspond to invalid (unused) states. See Section 7.7.1.

- 001 = Free-run
- 010 = Holdover
- 100 = Locked
- 101 = Prelocked 2
- 110 = Prelocked
- 111 = Loss-of-lock

Register Name: PTAB1
Register Description: Priority Table Register 1
Register Address: 0Ah

	Bit 7	Bit 6	Bit 5	Bit 4	Bit 3	Bit 2	Bit 1	Bit 0
Name	REF1[3:0]				SELREF[3:0]			
Default	0	0	0	0	0	0	0	0

Bits 7 to 4: Highest Priority Valid Reference (REF1[3:0]). This real-time status field indicates the highest-priority valid input reference. When T4T0 = 0 in the [MCR11](#) register, this field indicates the highest priority reference for the T0 DPLL. When T4T0 = 1, it indicates the highest priority reference for the T4 DPLL. Note that an input reference cannot be indicated in this field if it has been marked invalid in the [VALCR1](#) or [VALCR2](#) register. When the T0 DPLL is in non-revertive mode (REVERT = 0 in the [MCR3](#) register) this field may not have the same value as the SELREF[3:0] field. See Section [7.6.2](#).

0000 = No valid input reference available

0001 = Input IC1

0010 = Input IC2

0011 = Input IC3

0100 = Input IC4

0101 = Input IC5

0110 = Input IC6

0111 = Input IC7

1000 = Input IC8

1001 = Input IC9

1010 = Input IC10

1011 = Input IC11

1100 = Input IC12

1101 = Input IC13

1110 = Input IC14

1111 = {unused value}

Bits 3 to 0: Selected Reference (SELREF[3:0]). This real-time status field indicates the current selected reference. When T4T0 = 0 in the [MCR11](#) register, this field indicates the selected reference for the T0 DPLL. When T4T0 = 1, it indicates the selected reference for the T4 DPLL. Note that an input clock cannot be indicated in this field if it has been marked invalid in the [VALCR1](#) or [VALCR2](#) register. When the T0 DPLL is in nonrevertive mode (REVERT = 0 in the [MCR3](#) register) this field may not have the same value as the REF1[3:0] field. See Section [7.6.2](#).

0000 = No source currently selected

0001 = Input IC1

0010 = Input IC2

0011 = Input IC3

0100 = Input IC4

0101 = Input IC5

0110 = Input IC6

0111 = Input IC7

1000 = Input IC8

1001 = Input IC9

1010 = Input IC10

1011 = Input IC11

1100 = Input IC12

1101 = Input IC13

1110 = Input IC14

1111 = {unused value}

Register Name: PTAB2
Register Description: Priority Table Register 2
Register Address: 0Bh

	Bit 7	Bit 6	Bit 5	Bit 4	Bit 3	Bit 2	Bit 1	Bit 0
Name	REF3[3:0]				REF2[3:0]			
Default	0	0	0	0	0	0	0	0

Bits 7 to 4: Third Highest Priority Valid Reference (REF3[3:0]). This real-time status field indicates the third highest priority validated input reference. When T4T0 = 0 in the [MCR11](#) register, this field indicates the third highest priority reference for the T0 DPLL. When T4T0 = 1, it indicates the third highest reference for the T4 DPLL. Note that an input reference cannot be indicated in this field if it has been marked invalid in the [VALCR1](#) or [VALCR2](#) register. See Section [7.6.2](#).

0000 = Less than three valid sources available

0001 = Input IC1

0010 = Input IC2

0011 = Input IC3

0100 = Input IC4

0101 = Input IC5

0110 = Input IC6

0111 = Input IC7

1000 = Input IC8

1001 = Input IC9

1010 = Input IC10

1011 = Input IC11

1100 = Input IC12

1101 = Input IC13

1110 = Input IC14

1111 = {unused value}

Bits 3 to 0: Second Highest Priority Valid Reference (REF2[3:0]). This real-time status field indicates the second highest priority validated input reference. When T4T0 = 0 in the [MCR11](#) register, this field indicates the second highest priority reference for the T0 DPLL. When T4T0 = 1, it indicates the second highest reference for the T4 DPLL. Note that an input reference cannot be indicated in this field if it has been marked invalid in the [VALCR1](#) or [VALCR2](#) register. See Section [7.6.2](#).

0000 = Less than two valid sources available

0001 = Input IC1

0010 = Input IC2

0011 = Input IC3

0100 = Input IC4

0101 = Input IC5

0110 = Input IC6

0111 = Input IC7

1000 = Input IC8

1001 = Input IC9

1010 = Input IC10

1011 = Input IC11

1100 = Input IC12

1101 = Input IC13

1110 = Input IC14

1111 = {unused value}

Register Name: FREQ1
Register Description: Frequency Register 1
Register Address: 0Ch

	Bit 7	Bit 6	Bit 5	Bit 4	Bit 3	Bit 2	Bit 1	Bit 0
Name	FREQ[7:0]							
Default	0	0	0	0	0	0	0	0

The FREQ1, FREQ2 and FREQ3 registers must be read consecutively. See Section 8.3.

Bits 7 to 0: Current DPLL Frequency (FREQ[7:0]). The full 19-bit FREQ[18:0] field spans this register, FREQ2 and FREQ3. FREQ is a two's-complement signed integer that expresses the current frequency as an offset with respect to the master clock frequency (see Section 7.3). When T4T0 = 0 in the MCR11 register, FREQ indicates the current frequency offset of the T0 DPLL. When T4T0 = 1, FREQ indicates the current frequency offset of the T4 path. Because the value in this register field is derived from the DPLL integral path, it can be considered an average frequency with a rate of change inversely proportional to the DPLL bandwidth. If LIMINT = 1 in the MCR9 register, the value of FREQ freezes when the DPLL reaches its minimum or maximum frequency. The frequency offset in ppm is equal to FREQ[18:0] x 0.0003068. See Section 7.7.1.6.

Application Note: Frequency measurements are relative, i.e., they measure the frequency of the selected reference with respect to the local oscillator. As such, when a frequency difference exists, it is difficult to distinguish whether the selected reference is off frequency or the local oscillator is off frequency. In systems with timing card redundancy, the use of two timing cards, master and slave, can address this difficulty. Both master and slave have separate local oscillators, and each measures the selected reference. These two measurements provide the necessary information to distinguish which reference is off frequency, if we make the simple assumption that at most one reference has a significant frequency deviation at any given time (i.e. a single point of failure). If both master and slave indicate a significant frequency offset, then the selected reference must be off frequency. If the master indicates a frequency offset but the slave does not, then the master's local oscillator must be off frequency. Likewise, if the slave indicates a frequency offset but the master does not, then slave's local oscillator must be off frequency.

Register Name: FREQ2
Register Description: Frequency Register 2
Register Address: 0Dh

	Bit 7	Bit 6	Bit 5	Bit 4	Bit 3	Bit 2	Bit 1	Bit 0
Name	FREQ[15:8]							
Default	0	0	0	0	0	0	0	0

Bits 7 to 0: Current DPLL Frequency (FREQ[15:8]). See the FREQ1 register description.

Register Name: VALSR1
Register Description: Input Clock Valid Status Register 1
Register Address: 0Eh

	Bit 7	Bit 6	Bit 5	Bit 4	Bit 3	Bit 2	Bit 1	Bit 0
Name	<u>IC8</u>	<u>IC7</u>	<u>IC6</u>	<u>IC5</u>	<u>IC4</u>	<u>IC3</u>	<u>IC2</u>	<u>IC1</u>
Default	0	0	0	0	0	0	0	0

Bits 7 to 0: Input Clock Valid Status (IC8 to IC1). Each of these real-time status bits is set to 1 when the corresponding input clock is valid. An input is valid if it has no active alarms (HARD = 0, ACT = 0, LOCK = 0 in the corresponding [ISR](#) register). See also the [MSR1](#) register and Section 7.5.

0 = Invalid

1 = Valid

Register Name: VALSR2
Register Description: Input Clock Valid Status Register 2
Register Address: 0Fh

	Bit 7	Bit 6	Bit 5	Bit 4	Bit 3	Bit 2	Bit 1	Bit 0
Name	<u>FHORDY</u>	<u>SHORDY</u>	<u>IC14</u>	<u>IC13</u>	<u>IC12</u>	<u>IC11</u>	<u>IC10</u>	<u>IC9</u>
Default	0	0	0	0	0	0	0	0

Bit 7: Fast Holdover Frequency Ready (FHORDY). This real-time status bit is set to 1 when the T0 DPLL has a holdover value that has been averaged over the 8-minute holdover averaging period. See the related latched status bit in [MSR4](#) and Section 7.7.1.6.

Bit 6: Slow Holdover Frequency Ready (SHORDY). This real-time status bit is set to 1 when the T0 DPLL has a holdover value that has been averaged over the 110-minute holdover averaging period. See the related latched status bit in [MSR4](#) and Section 7.7.1.6.

Bits 5 to 0: Input Clock Valid Status (IC14 to IC9). These bits have the same behavior as the bits in [VALSR1](#) but for the IC9 through IC14 input clocks.

Register Name: ISR1
Register Description: Input Status Register 1
Register Address: 10h

	Bit 7	Bit 6	Bit 5	Bit 4	Bit 3	Bit 2	Bit 1	Bit 0
Name	<u>SOFT2</u>	<u>HARD2</u>	<u>ACT2</u>	<u>LOCK2</u>	<u>SOFT1</u>	<u>HARD1</u>	<u>ACT1</u>	<u>LOCK1</u>
Default	0	1	1	0	0	1	1	0

Bit 7: Soft Frequency Limit Alarm for Input Clock 2 (SOFT2). This real-time status bit indicates a soft frequency limit alarm for input clock 2. If IC2 is the selected reference then SOFT2 is set to 1 when the frequency of IC2 is greater than or equal to the soft limit set in the [SRLIMIT](#) register. If IC2 is not the selected reference then SOFT2 is set to 1 when the frequency of IC2 is greater than or equal to the soft limit set in the [ILIMIT](#) register. Soft alarms are disabled by default but can be enabled by setting SOFTEN = 1 in the [MCR10](#) register. A soft alarm does not invalidate an input clock. See Section [7.5.1](#).

Bit 6: Hard Frequency Limit Alarm for Input Clock 2 (HARD2). This real-time status bit indicates a hard frequency limit alarm for input clock 2. If IC2 is the selected reference then HARD2 is set to 1 when the frequency of IC2 is greater than or equal to the hard limit set in the [SRLIMIT](#) register. If IC2 is not the selected reference then HARD2 is set to 1 when the frequency of IC2 is greater than or equal to the hard limit set in the [ILIMIT](#) register. Hard alarms are enabled by default but can be disabled by setting HARDEN = 0 in the [MCR10](#) register. A hard alarm clears the IC2 status bit in the [VALSR1](#) register, invalidating the IC2 clock. See Section [7.5.1](#).

Bit 5: Activity Alarm for Input Clock 2 (ACT2). This real-time status bit is set to 1 when the leaky bucket accumulator for IC2 reaches the alarm threshold specified in the [LBxU](#) register (where 'x' in 'LBxU' is specified in the BUCKET field of [ICR2](#)). An activity alarm clears the IC2 status bit in the [VALSR1](#) register, invalidating the IC2 clock. See Section [7.5.2](#).

Bit 4: Phase Lock Alarm for Input Clock 2 (LOCK2). This status bit is set to 1 if IC2 is the selected reference and the T0 DPLL cannot phase lock to IC2 within the duration specified in the [PHLKTO](#) register (default = 100 seconds). A phase lock alarm clears the IC2 status bit in [VALSR1](#), invalidating the IC2 clock. If LKATO = 1 in [MCR3](#) then LOCK2 is automatically cleared after a timeout period of 128 seconds. LOCK2 is a read/write bit. System software can clear LOCK2 by writing 0 to it, but writing 1 is ignored. See Section [7.7.1](#).

Bit 3: Soft Frequency Limit Alarm for Input Clock 1 (SOFT1). This bit has the same behavior as the SOFT2 bit but for the IC1 input clock.

Bit 2: Hard Frequency Limit Alarm for Input Clock 1 (HARD1). This bit has the same behavior as the HARD2 bit but for the IC1 input clock.

Bit 1: Activity Alarm for Input Clock 1 (ACT1). This bit has the same behavior as the ACT2 bit but for the IC1 input clock.

Bit 0: Phase Lock Alarm for Input Clock 1 (LOCK1). This bit has the same behavior as the LOCK2 bit but for the IC1 input clock.

Register Name: ISR2, ISR3, ISR4, ISR5, ISR6, ISR7
Register Description: Input Status Register 2, 3, 4, 5, 6, 7
Register Address: 11h, 12h, 13h, 14h, 15h, 16h

	Bit 7	Bit 6	Bit 5	Bit 4	Bit 3	Bit 2	Bit 1	Bit 0
Name	<u>SOFT</u> _n	<u>HARD</u> _n	<u>ACT</u> _n	<u>LOCK</u> _n	<u>SOFT</u> _m	<u>HARD</u> _m	<u>ACT</u> _m	<u>LOCK</u> _m
Default	0	1	1	0	0	1	1	0

These registers have the same behavior as [ISR1](#) but for the other input clocks, as follows:

INPUT CLOCKS	REGISTER
IC4 and IC3	ISR2
IC6 and IC5	ISR3
IC8 and IC7	ISR4
IC10 and IC9	ISR5
IC12 and IC11	ISR6
IC14 and IC13	ISR7

Register Name: MSR4
Register Description: Master Status Register 4
Register Address: 17h

	Bit 7	Bit 6	Bit 5	Bit 4	Bit 3	Bit 2	Bit 1	Bit 0
Name	FHORDY	SHORDY	MRAA	—	IC2NO4	IC1NO4	IC2NO8	IC1NO8
Default	0	0	0	0	0	0	0	0

Bit 7: Fast Holdover Frequency Ready (FHORDY). This latched status bit is set to 1 when the T0 DPLL has a holdover value that has been averaged over the 8-minute holdover averaging period. FHORDY is cleared when written with a 1. When FHORDY is set it can cause an interrupt request on the INTREQ pin if the FHORDY interrupt enable bit is set in the [IER4](#) register. See Section [7.7.1.6](#).

Bit 6: Slow Holdover Frequency Ready (SHORDY). This latched status bit is set to 1 when the T0 DPLL has a holdover value that has been averaged over the 110-minute holdover averaging period. SHORDY is cleared when written with a 1. When SHORDY is set it can cause an interrupt request on the INTREQ pin if the SHORDY interrupt enable bit is set in the [IER4](#) register. See Section [7.7.1.6](#).

Bit 5: Multi-Register Access Aborted (MRAA). This latched status bit is set to 1 when a multi-byte access (read or write) is interrupted by another access to the device. MRAA is cleared when written with a 1. MRAA cannot cause an interrupt to occur. See Section [8.3](#).

Bit 3: Input Clock 2 Has No 400Hz Component (IC2NO4). This latched status bit is set to 1 when the missing BPVs that indicate the 400Hz component cannot be found in a 5ms period (two 400Hz cycles). IC2NO4 is cleared when written with a 1 unless the 400Hz component is still not present. When IC2NO4 is set it can cause an interrupt request on the INTREQ pin if the IC2NO4 interrupt enable bit is set in the [IER4](#) register. This status bit is only enabled when IC2 is configured as a composite clock receiver ([MCR5:IC2SF](#) = 0). See Section [7.11.1](#).

Bit 2: Input Clock 1 Has No 400Hz Component (IC1NO4). This latched status bit is set to 1 when the missing BPVs that indicate the 400Hz component cannot be found in a 5ms period (two 400Hz cycles). IC1NO4 is cleared when written with a 1 unless the 400Hz component is still not present. When IC1NO4 is set it can cause an interrupt request on the INTREQ pin if the IC1NO4 interrupt enable bit is set in the [IER4](#) register. This status bit is only enabled when IC1 is configured as a composite clock receiver ([MCR5:IC1SF](#) = 0). See Section [7.11.1](#).

Bit 1: Input Clock 2 Has No 8kHz Component (IC2NO8). This latched status bit is set to 1 when the BPVs that indicate the 8kHz component cannot be found in the incoming signal in a 500 μ s period (four 8kHz cycles). IC2NO8 is cleared when written with a 1 unless the 8kHz component is still not present. When IC2NO8 is set it can cause an interrupt request on the INTREQ pin if the IC2NO8 interrupt enable bit is set in the [IER4](#) register. This status bit is only enabled when IC2 is configured as a composite clock receiver ([MCR5:IC2SF](#) = 0). See Section [7.11.1](#).

Bit 0: Input Clock 1 Has No 8kHz Component (IC1NO8). This latched status bit is set to 1 when the BPVs that indicate the 8kHz component cannot be found in the incoming signal in a 500 μ s period (four 8kHz cycles). IC1NO8 is cleared when written with a 1 unless the 8kHz component is still not present. When IC1NO8 is set it can cause an interrupt request on the INTREQ pin if the IC1NO8 interrupt enable bit is set in the [IER4](#) register. This status bit is only enabled when IC1 is configured as a composite clock receiver ([MCR5:IC1SF](#) = 0). See Section [7.11.1](#).

Register Name: IPR1
Register Description: Input Priority Register 1
Register Address: 18h

	Bit 7	Bit 6	Bit 5	Bit 4	Bit 3	Bit 2	Bit 1	Bit 0
Name	PRI2[3:0]				PRI1[3:0]			
Default (T0)	0	0	1	1	0	0	1	0
Default (T4)	0	0	0	0	0	0	0	0

Bits 7 to 4: Priority for Input Clock 2 (PRI2). Priority 0001 is highest; priority 1111 is lowest. When **MCR11:T4T0** = 0, PRI2 configures IC2's priority for the T0 DPLL. When **T4T0** = 1, PRI2 configures IC2's priority for the T4 path. See Section 7.6.1.

0000 = IC2 unavailable for selection.

0001–1111 = IC2 relative priority

Bits 3 to 0: Priority for Input Clock 1 (PRI1). Priority 0001 is highest; priority 1111 is lowest. When **MCR11:T4T0** = 0, PRI1 configures IC1's priority for the T0 DPLL. When **T4T0** = 1, PRI1 configures IC1's priority for the T4 path. See Section 7.6.1.

0000 = IC1 unavailable for selection.

0001–1111 = IC1 relative priority

Register Name: IPR2, IPR3, IPR4, IPR5, IPR6, IPR7
Register Description: Input Priority Register 2, 3, 4, 5, 6, 7
Register Address: 19h, 1Ah, 1Bh, 1Ch, 1Dh, 1Eh

	Bit 7	Bit 6	Bit 5	Bit 4	Bit 3	Bit 2	Bit 1	Bit 0
Name	PRIn[3:0]				PRIm[3:0]			
Default	see table							

These registers have the same behavior as **IPR1** but for the other input clocks, as follows:

INPUT CLOCKS	REGISTER	DEFAULT (T0)	DEFAULT (T4)
IC4 and IC3	IPR2	0101 0100	0000 0000
IC6 and IC5	IPR3	0111 0110	0111 0110
IC8 and IC7	IPR4	1001 1000	1001 1000
IC10 and IC9	IPR5	1011 1010	1011 1010
IC12 and IC11	IPR6	1101 1100 or 1101 0001*	0000 0000
IC14 and IC13	IPR7	1111 1110	0000 0000

*In register **IPR6**, for the T0 path, if the **MASTSLV** pin is high (master mode) when $\overline{RST} = 0$ then the default priority of input IC11 (**PRI11**) is 12. If the **MASTSLV** pin is low (slave mode) when $\overline{RST} = 0$, then the default priority of IC11 is 1. When the device is in slave mode values written to **PRI11[3:0]** are latched, but the value read is always 0001 to indicate that input 11 is forced to have priority 1. See Section 7.9.1.

Register Name: ICR1, ICR2, ICR3, ICR4, ICR5, ICR6, ICR7, ICR8, ICR9, ICR10, ICR11, ICR12, ICR13, ICR14
Register Description: Input Configuration Register 1, 2, 3, 4, 5, 6, 7, 8, 9, 10, 11, 12, 13, 14
Register Address: 20h, 21h, 22h, 23h, 24h, 25h, 26h, 27h, 28h, 29h, 2Ah, 2Bh, 2Ch, 2Dh

	Bit 7	Bit 6	Bit 5	Bit 4	Bit 3	Bit 2	Bit 1	Bit 0
Name	DIVN	LOCK8K	BUCKET[1:0]		FREQ[3:0]			
Default	0	0	0	0	See below			

These registers are identical in function. ICR_x is the control register for input clock IC_x.

Bit 7: DIVN Mode (DIVN). When DIVN is set to 1, the input clock is divided down by a programmable pre-divider. The resulting output clock is then passed to the DPLL and frequency monitor. All input clocks for which DIVN = 1 are divided by the factor specified in [DIVN1](#) and [DIVN2](#). When DIVN = 1 in an [ICR](#) register, the FREQ field of that register must be set to 8kHz. See Section [7.4.2.3](#).

0 = Disabled
 1 = Enabled

Bit 6: LOCK8K Mode (LOCK8K). When LOCK8K is set to 1, the input clock is divided down by a preset predivider. The resulting output clock, which is always 8kHz, is then passed to the DPLL. LOCK8K is ignored when DIVN = 1. LOCK8K is also ignored when DIVN=0 and FREQ[3:0] = 1001 (2kHz) or 1010 (4kHz). See Section [7.4.2.2](#).

0 = Disabled
 1 = Enabled

Bits 5 to 4: Leaky Bucket Configuration (BUCKET[1:0]). Each input clock has leaky bucket accumulator logic in its activity monitor. The [LB_{xy}](#) registers at addresses 50h to 5Fh specify four different leaky bucket configurations. Any of the four configurations can be specified for the input clock. See Section [7.5.2](#).

00 = leaky bucket configuration 0
 01 = leaky bucket configuration 1
 10 = leaky bucket configuration 2
 11 = leaky bucket configuration 3

Bits 3 to 0: Input Clock Nominal Frequency (FREQ[3:0]). This field specifies the input clock's nominal frequency. FREQ must be set to 0000 if DIVN = 1. See Section [7.4.2](#).

0000 = 8kHz
 0001 = 1544kHz or 2048kHz (as determined by SONSDH bit in the [MCR3](#) register)
 0010 = 6.48MHz
 0011 = 19.44MHz
 0100 = 25.92MHz
 0101 = 38.88MHz
 0110 = 51.84MHz
 0111 = 77.76MHz
 1000 = 155.52MHz (only valid for IC5 and IC6)
 1001 = 2kHz
 1010 = 4kHz
 1011 = 6312kHz
 1100–1111 {unused values}

FREQ[3:0] Default Values:

ICR1–ICR4: 0000b
 ICR5–ICR10: 0011b
 ICR11: 0010b if MASTSLV = 0
 0011b if MASTSLV = 1
 ICR12–ICR14: 0001b

Note that the ICR11 default value is set based on the state of the MASTSLV pin when the $\overline{\text{RST}}$ pin is asserted. See Section [7.13](#).

Register Name: VALCR1
Register Description: Input Clock Valid Control Register 1
Register Address: 30h

	Bit 7	Bit 6	Bit 5	Bit 4	Bit 3	Bit 2	Bit 1	Bit 0
Name	IC8	IC7	IC6	IC5	IC4	IC3	IC2	IC1
Default	1	1	1	1	1	1	1	1

Bits 7 to 0: Input Clock Valid Control (IC8 to IC1). These control bits can be used to force input clocks to be considered invalid. If a clock is invalidated by one of these control bits it will not appear in the priority table in the PTAB1 and PTAB2 registers, even if the clock is otherwise valid. One key application for these control bits is to force clocks invalid that are declared invalid in the other DS3100 device of a redundant pair. Note that setting a VALCR bit low has no effect on the corresponding bit in the VALSR registers. See Sections 7.6.2 and 7.9.1.

0 = Force invalid

1 = Do not force invalid; determine validity normally

Register Name: VALCR2
Register Description: Input Clock Valid Control Register 2
Register Address: 31h

	Bit 7	Bit 6	Bit 5	Bit 4	Bit 3	Bit 2	Bit 1	Bit 0
Name	—	—	IC14	IC13	IC12	IC11	IC10	IC9
Default	0	0	1	1	1	1	1	1

Bits 5 to 0: Input Clock Valid Control (IC14 to IC9). These bits have the same behavior as the bits in VALCR1 but for the IC9 through IC14 input clocks.

Register Name: MCR1
Register Description: Master Configuration Register 1
Register Address: 32h

	Bit 7	Bit 6	Bit 5	Bit 4	Bit 3	Bit 2	Bit 1	Bit 0
Name	RST	—	—	—	—	T0STATE[2:0]		
Default	0	0	0	0	0	0	0	0

Bit 7: Device Reset (RST). When this bit is high the entire device is held in reset, and all register fields, except the RST bit itself, are reset to their default states. When RST is active, the register fields with pin-programmed defaults do not latch their values from the corresponding input pins. Instead these fields are reset to the default values that were latched from the pins when the $\overline{\text{RST}}$ pin was last active. See Section 7.13.

0 = Normal operation

1 = Reset

Bits 2 to 0: T0 DPLL State Control (T0STATE). This field allows the T0 DPLL state machine to be forced to a specified state. The state machine will remain in the forced state, and therefore cannot react to alarms and other events, as long as T0STATE is not equal to 000. See Section 7.7.1.

000 = Automatic (normal state machine operation)

001 = Free-run

010 = Holdover

011 = {unused value}

100 = Locked

101 = Prelocked 2

110 = Prelocked

111 = Loss-of-lock

Register Name: MCR2
Register Description: Master Configuration Register 2
Register Address: 33h

	Bit 7	Bit 6	Bit 5	Bit 4	Bit 3	Bit 2	Bit 1	Bit 0
Name	—	—	—	—	T0FORCE[3:0]			
Default	0	0	0	0	1	1	1	1

Bits 3 to 0: T0 DPLL Force Selected Reference (T0FORCE[3:0]). This field provides a way to force a specified input clock to be the selected reference for the T0 DPLL. Internally this is accomplished by forcing the clock to have the highest priority (as specified in [PTAB1:REF1](#)). In revertive mode ([MCR3:REVERT](#) = 1) the forced clock automatically becomes the selected reference (as specified in [PTAB1:SELREF](#)) as well. In nonrevertive mode, the forced clock only becomes the selected reference when the existing selected reference is invalidated or made unavailable for selection.

When a reference is forced, the activity monitor and frequency monitor for that input and the T0 DPLL's loss-of-lock timeout logic all continue to operate and affect the relevant [ISR](#), [VALSR](#) and [MSR](#) register bits. However, when the reference is declared invalid the T0 DPLL is not allowed to switch to another input clock. The T0 DPLL continues to respond to the fast activity monitor and the invalidate-on-event logic in the BITS receivers (register [BCCR5](#)) and CC receivers (register [MCR5](#)), transitioning to miniholdover in response to short-term events and to full holdover in response to longer events. See Section [7.6.3](#).

0000 = Automatic source selection (normal operation)

0001 = Force to IC1

0010 = Force to IC2

0011 = Force to IC3

0100 = Force to IC4

0101 = Force to IC5

0110 = Force to IC6

0111 = Force to IC7

1000 = Force to IC8

1001 = Force to IC9

1010 = Force to IC10

1011 = Force to IC11

1100 = Force to IC12

1101 = Force to IC13

1110 = Force to IC14

1111 = Automatic source selection (normal operation)

Register Name: MCR3
Register Description: Master Configuration Register 3
Register Address: 34h

	Bit 7	Bit 6	Bit 5	Bit 4	Bit 3	Bit 2	Bit 1	Bit 0
Name	AEFSEN	LKATO	XOEDGE	MANHO	EFSEN	SONSDH	MASTSLV	REVERT
Default	1	1	0	0	0	see below	see below	0

Bit 7: Auto External Frame Sync Enable (AEFSEN). See Section 7.9.3.

0 = EFSEN bit (bit 3 below) enables and disables the external frame sync on the SYNC2K pin

1 = The external frame sync is enabled when EFSEN = 1 and the T0 DPLL is locked to the input clock specified in the SOURCE field of FSCR3.

Bit 6: Phase Lock Alarm Timeout (LKATO). This bit controls how phase alarms on input clocks can be terminated. Phase alarms are indicated by the LOCK bits in ISR registers

0 = Phase alarms on input clocks can only be cancelled by software

1 = Phase alarms are automatically cancelled after a timeout period of 128 seconds

Bit 5: Local Oscillator Edge (XOEDGE). This bit specifies the significant clock edge of the local oscillator clock signal on the REFCLK input pin. The faster edge should be selected for best jitter performance. See Section 7.3.

0 = Rising edge

1 = Falling edge

Bit 4: Manual Holdover (MANHO). When this bit is set to 1 the T0 DPLL holdover frequency is set by the HOFREQ field in the HOCR1, HOCR2 and HOCR3 registers. When MANHO = 1 it has priority over any other holdover control fields. See Section 7.7.1.6.

0 = Standard holdover: holdover frequency is learned by the T0 DPLL from the selected reference

1 = Manual holdover: holdover frequency is taken from the HOFREQ field

Bit 3: External Frame Sync Enable (EFSEN). When this bit is set to 1 the T0 DPLL looks for a reference frame sync pulse on the SYNC2K pin. See the AEFSEN bit description above for more information. See Section 7.9.3.

0 = Disable external frame sync; ignore SYNC2K pin

1 = Enable external frame sync on SYNC2K pin

Bit 2: SONET or SDH Frequencies (SONSDH). This bit specifies the clock rate for input clocks with FREQ=0001 in the ICR registers (20h to 2Dh). During reset the default value of this bit is latched from the SONSDH pin. See Section 7.4.2.

0 = 2048kHz

1 = 1544 Hz

Bit 1: Master or Slave Configuration (MASTSLV). This read-only bit indicates the state of the MASTSLV pin. This bit therefore does not have a fixed default value. To disable the master-slave pin feature and give software the ability to configure devices as either master or slave, wire the MASTSLV pin high (master mode) on both devices. See Section 7.9.

0 = Slave Mode. In this mode input clock IC11 is set to priority 1 (highest), the T0 DPLL is set to acquisition bandwidth, revertive mode is enabled, and phase build-out is disabled.

1 = Master Mode. In this mode all settings are configured by configuration registers.

Bit 0: Revertive Mode (REVERT). This bit configures the T0 DPLL for revertive or non-revertive operation. (The T4 DPLL is always revertive). In revertive mode, if an input clock with a higher priority than the selected reference becomes valid, the higher-priority reference immediately becomes the selected reference. In nonrevertive mode, the higher priority reference does not immediately become the selected reference but does become the highest-priority reference in the priority table (REF1 field in the PTAB1 register). See Section 7.6.2.

When the device is in slave mode (MASTSLV pin = 0) values written to this field are latched, but the value read is always 1 to indicate that the device is forced into revertive mode. See Section 7.9.1.

0 = Nonrevertive mode

1 = Revertive mode

Register Name: MCR4
Register Description: Master Configuration Register 4
Register Address: 35h

	Bit 7	Bit 6	Bit 5	Bit 4	Bit 3	Bit 2	Bit 1	Bit 0
Name	LKT4T0	T4DFB	—	OC89	T4FORCE[3:0]			
Default	0	1	0	0	0	0	0	0

Bit 7: Lock T4 to T0 (LKT4T0). When this bit is set to 0 the T4 path operates independently from the T0 path. When it is set to 1 the T4 path locks to the output of the T0 DPLL, which allows the T4 path to be used to synthesize additional clock frequencies that are locked to the T0 reference. See Section 7.8.2.2.

- 0 = T4 path operates independently from T0 path
- 1 = T4 DPLL locks to the output of the T0 DPLL

Bit 6: T4 Digital Feedback Mode (T4DFB). See Section 7.8.2.2.

- 0 = Analog feedback mode
- 1 = Digital feedback mode

Bit 4: Source Control for Clock Outputs 8 and 9 (OC89). See Section 7.8.2.4.

- 0 = OC8 and OC9 generated from T4 DPLL
- 1 = OC8 and OC9 generated from T0 DPLL

Bits 3 to 0: T4 DPLL Force Selected Reference (T4FORCE[3:0]). This field provides a way to force a specified input clock to be the selected reference for the T4 DPLL. Internally this is accomplished by forcing the clock to have the highest priority (as specified in PTAB1:REF1). Since the T4 DPLL always operates in revertive mode, the forced clock automatically becomes the selected reference (as specified in PTAB1:SELREF) as well.

When a reference is forced, the activity monitor and frequency monitor for that input continue to operate and affect the relevant *ISR*, *VALSR* and *MSR* register bits. However, when the reference is declared invalid, the T4 DPLL is not allowed to switch to another input clock. See Section 7.6.3.

- 0000 = Automatic (normal operation)
- 0001 = Force to IC1
- 0010 = Force to IC2
- 0011 = Force to IC3
- 0100 = Force to IC4
- 0101 = Force to IC5
- 0110 = Force to IC6
- 0111 = Force to IC7
- 1000 = Force to IC8
- 1001 = Force to IC9
- 1010 = Force to IC10
- 1011 = Force to IC11
- 1100 = Force to IC12
- 1101 = Force to IC13
- 1110 = Force to IC14
- 1111 = Automatic (normal operation)

Register Name: MCR5
Register Description: Master Configuration Register 5
Register Address: 36h

	Bit 7	Bit 6	Bit 5	Bit 4	Bit 3	Bit 2	Bit 1	Bit 0
Name	CCEDGE	BITERR	AMI	LOS	IC2SF	IC1SF	IC6SF	IC5SF
Default	0	0	0	0	0	0	1	0

Bit 7: Composite Clock 8kHz Edge (CCEDGE). This bit specifies the 8kHz clock edge in the incoming composite clock signals on inputs IC1 and IC2. See Section 7.11.1.

- 0 = The leading edge of the pulse following the BPV
- 1 = The leading edge of the BPV

Bit 6: Increment the Activity Monitor on Bit Errors (BITERR). If this bit is set to 1, then the detection of a deviation from the one-BPV-in-eight pattern on IC1 or IC2 (in composite clock mode) is considered an irregularity by the corresponding activity monitor. The activity monitors increment their leaky bucket accumulators once for each 128ms interval in which irregularities occur. See Section 7.11.1.

- 0 = Bit errors do not increment the input clock activity monitors
- 1 = Bit errors do increment the input clock activity monitors

Bit 5: Invalidate on AMI Violation (AMI). If this bit is set to 1, then the detection of a deviation from the one-BPV-in-eight pattern in each of two consecutive 8-bit periods on IC1 or IC2 (in composite clock mode) automatically invalidates the offending clock. See Section 7.11.1.

- 0 = Do not invalidate on AMI violation
- 1 = Invalidate on incorrect AMI violation

Bit 4: Invalidate on Loss of Signal (LOS). If this bit is set to 1, then the detection of two consecutive zeros on IC1 or IC2 (in composite clock mode) automatically invalidates the offending clock. See Section 7.11.1.

- 0 = Do not invalidate on LOS
- 1 = Invalidate on LOS

Bit 3: Input Clock 2 Signal Format (IC2SF). See Section 7.11.1.

- 0 = AMI 64kHz composite clock on the IC2A pin
- 1 = CMOS/TTL on the IC2 pin

Bit 2: Input Clock 1 Signal Format (IC1SF). See Section 7.11.1.

- 0 = AMI 64 kHz composite clock on the IC1A pin
- 1 = CMOS/TTL on the IC1 pin

Bit 1: Input Clock 6 Signal Format (IC6SF). For backward compatibility this bit can be written to and read back, but it does not affect the IC6POS/NEG inputs pins, which are automatically accept LVDS and LVPECL signals without reconfiguration. See Section 7.4.1.

- 0 = LVDS compatible
- 1 = LVPECL compatible (default)

Bit 0: Input Clock 5 Signal Format (IC5SF). For backward compatibility this bit can be written to and read back, but it does not affect the IC5POS/NEG inputs pins, which are automatically accept LVDS and LVPECL signals without reconfiguration. See Section 7.4.1.

- 0 = LVDS compatible (default)
- 1 = LVPECL compatible

Register Name: IFSR
Register Description: Microprocessor Interface Selection Status Register
Register Address: 37h

	Bit 7	Bit 6	Bit 5	Bit 4	Bit 3	Bit 2	Bit 1	Bit 0
Name	—	—	—	—	—	IFSEL[2:0]		
Default	0	0	0	0	0	set by IFSEL[2:0] pins when $\overline{\text{RST}} = 0$		

Bits 2 to 0: Microprocessor Interface Selection (IFSEL[2:0]). This read-only field shows the current state of the IFSEL[2:0] pins. When $\overline{\text{RST}} = 0$ the state of the IFSEL pins is latched into the microprocessor interface control register (IFCR). After $\overline{\text{RST}}$ is brought high, the IFSEL pins are ignored by the interface control logic and can be used as general-purpose inputs whose values are shown in this register field. See Section 7.12.

Register Name: MCR6
Register Description: Master Configuration Register 6
Register Address: 38h

	Bit 7	Bit 6	Bit 5	Bit 4	Bit 3	Bit 2	Bit 1	Bit 0
Name	DIG2AF	DIG2SS	DIG1SS	—	—	—	—	—
Default	0	see below	see below	1	1	1	1	1

Bit 7: Digital2 Alternate Frequency (DIG2AF). See Section 7.8.2.1.

0 = Digital2 frequency specified by DIG2SS and MCR7:DIG2F.

1 = Digital2 frequency is 6312kHz (must set DIG2SS = 0 and MCR7:DIG2F = 00)

Bit 6: Digital2 SONET or SDH Frequencies (DIG2SS). This bit specifies whether the clock rates generated by the Digital2 clock synthesizer are multiples of 1.544MHz (SONET compatible) or multiples of 2.048MHz (SDH compatible). The specific multiple is set in the DIG2F field of the MCR7 register. When $\overline{\text{RST}} = 0$ the default value of this bit is latched from the SONSDH pin. See Section 7.8.2.1.

0 = Multiples of 2048kHz

1 = Multiples of 1544kHz

Bit 5: Digital1 SONET or SDH Frequencies (DIG1SS). This bit specifies whether the clock rates generated by the Digital1 clock synthesizer are multiples of 1544kHz (SONET compatible) or multiples of 2048kHz (SDH compatible). The specific multiple is set in the DIG1F field of the MCR7 register. When $\overline{\text{RST}} = 0$ the default value of this bit is latched from the SONSDH pin. See Section 7.8.2.1.

0 = Multiples of 2048kHz

1 = Multiples of 1544kHz

Register Name: MCR7
Register Description: Master Configuration Register 7
Register Address: 39h

	Bit 7	Bit 6	Bit 5	Bit 4	Bit 3	Bit 2	Bit 1	Bit 0
Name	DIG2F[1:0]		DIG1F[1:0]		—	—	—	—
Default	0	0	0	0	1	0	0	0

Bits 7 to 6: Digital2 Frequency (DIG2F[1:0]). This field and DIG2SS of [MCR6](#) configure the frequency of the Digital2 clock synthesizer. See Section [7.8.2.1](#).

<u>DIG2SS = 1</u>	<u>DIG2SS = 0</u>
00 = 1544kHz	00 = 2048kHz
01 = 3088kHz	01 = 4096kHz
10 = 6176kHz	10 = 8192kHz
11 = 12352kHz	11 = 16384kHz

Bits 5 to 4: Digital1 Frequency (DIG1F[1:0]). This field and DIG1SS of [MCR6](#) configure the frequency of the Digital1 clock synthesizer. See Section [7.8.2.1](#).

<u>DIG1SS = 1</u>	<u>DIG1SS = 0</u>
00 = 1544kHz	00 = 2048kHz
01 = 3088kHz	01 = 4096kHz
10 = 6176kHz	10 = 8192kHz
11 = 12352kHz	11 = 16384kHz

Register Name: MCR8
Register Description: Master Configuration Register 8
Register Address: 3Ah

	Bit 7	Bit 6	Bit 5	Bit 4	Bit 3	Bit 2	Bit 1	Bit 0
Name	—	—	OC8400	OC8NO8	OC7SF		OC6SF	
Default	1	1	0	0	0	1	1	0

Bit 5: Output Clock 8, 400Hz Component Enable (OC8400). See Section [7.11.2](#).

0 = 400 Hz component disabled
1 = 400 Hz component enabled

Bit 4: Output Clock 8, 8kHz Component Disable (OC8NO8). See Section [7.11.2](#).

0 = 8 kHz component enabled
1 = 8 kHz component disabled

Bits 3 to 2: Output Clock 7 Control (OC7SF[1:0]). See Section [7.8.1](#).

00 = Output disabled
01 = 3V LVDS compatible (default)
10 = 3V LVDS compatible
11 = 3V LVDS compatible

Bits 1 to 0: Clock Output 6 Control (OC6SF[1:0]). See Section [7.8.1](#).

00 = Output disabled
01 = 3V LVDS compatible
10 = 3V LVDS compatible (default)
11 = 3V LVDS compatible

Register Name: MCR9
Register Description: Master Configuration Register 9
Register Address: 3Bh

	Bit 7	Bit 6	Bit 5	Bit 4	Bit 3	Bit 2	Bit 1	Bit 0
Name	AUTOBW	—	—	—	LIMINT	PFD180	—	—
Default	1	1	1	1	1	0	1	1

Bit 7: Automatic Bandwidth Selection (AUTOBW). When the device is in slave mode (MASTSLV pin = 0), this field is ignored and the T0 DPLL is forced to use acquisition bandwidth. See Section 7.7.3.

0 = Always selects locked bandwidth from the T0LBW register

1 = Automatically selects either locked bandwidth (T0LBW register) or acquisition bandwidth (T0ABW register) as appropriate

Bit 3: Limit Integral Path (LIMINT). When this bit is set to 1, the T0 DPLL's integral path is limited (i.e., frozen) when the DPLL reaches minimum or maximum frequency, as set by the HARDLIM field in DLIMIT1 and DLIMIT2. When the integral path is frozen, the current DPLL frequency in registers FREQ1, FREQ2 and FREQ3 is also frozen. Setting LIMINT = 1 minimizes overshoot when the DPLL is pulling in. See Section 7.7.3.

0 = Do not freeze integral path at min/max frequency

1 = Freeze integral path at min/max frequency

Bit 2: 180° PFD Enable (PFD180). If TEST1:D180 = 1, then PFD180 has no effect.

0 = Use 180° phase detector (nearest-edge locking mode)

1 = Use 180° phase-frequency detector

Register Name: MCLK1
Register Description: Master Clock Frequency Adjustment Register 1
Register Address: 3Ch

	Bit 7	Bit 6	Bit 5	Bit 4	Bit 3	Bit 2	Bit 1	Bit 0
Name	MCLKFREQ[7:0]							
Default	1	0	0	1	1	0	0	1

The MCLK1 and MCLK2 registers must be read consecutively and written consecutively. See Section 8.3.

Bits 7 to 0: Master Clock Frequency Adjustment (MCLKFREQ[7:0]). The full 16-bit MCLKFREQ[15:0] field spans this register and MCLK2. MCLKFREQ is an unsigned integer that adjusts the frequency of the internal 204.8MHz master clock with respect to the frequency of the local oscillator clock on the REFCLK pin by up to +514ppm and -771ppm. The master clock adjustment has the effect of speeding up the master clock with a positive adjustment and slowing it down with a negative adjustment. For example, if the oscillator connected to REFCLK has an offset of +1ppm then the adjustment should be -1ppm to correct the offset.

The formulas below translate adjustments to register values and vice versa. The default register value of 39,321 corresponds to 0ppm. See Section 7.3.

$$\text{MCLKFREQ}[15:0] = \text{adjustment_in_ppm} / 0.0196229 + 39,321$$

$$\text{adjustment_in_ppm} = (\text{MCLKFREQ}[15:0] - 39,321) \times 0.0196229$$

Register Name: MCLK2
Register Description: Master Clock Frequency Adjustment Register 2
Register Address: 3Dh

	Bit 7	Bit 6	Bit 5	Bit 4	Bit 3	Bit 2	Bit 1	Bit 0
Name	MLCKFREQ[15:8]							
Default	1	0	0	1	1	0	0	1

Bits 7 to 0: Master Clock Frequency Adjustment (MCLKFREQ[15:8]). See the MCLK1 register description.

Register Name: HOCR1
Register Description: Holdover Configuration Register 1
Register Address: 3Eh

	Bit 7	Bit 6	Bit 5	Bit 4	Bit 3	Bit 2	Bit 1	Bit 0
Name	HOFREQ[7:0]							
Default	0	0	0	0	0	0	0	0

Bits 7 to 0: Holdover Frequency (HOFREQ[7:0]). The full 19-bit HOFREQ[18:0] field spans this register, [HOCR2](#) and [HOCR3](#). HOFREQ is a two's-complement signed integer, and it expresses the holdover frequency as an offset with respect to the master clock frequency (see Section 7.3). Writing this field sets the T0 DPLL's manual holdover frequency, which is used when MANHO = 1 in the [MCR3](#) register. When [HOCR3:RDAVG](#) = 0, reading the HOFREQ field returns the manual holdover value previously written. When RDAVG = 1, reading the HOFREQ field returns the T0 DPLL's averaged frequency, either the fast average (if [HOCR3:FAST](#) = 1) or the slow average (if FAST = 0). The HOFREQ field has the same size and format as the [FREQ\[18:0\]](#) field ([FREQ1](#), [FREQ2](#) and [FREQ3](#) registers) to allow software to read FREQ, filter the value, and then write to HOFREQ. Holdover frequency offset in ppm is equal to HOFREQ[18:0] x 0.0003068. See Section 7.7.1.6.

Note: After either [HOCR3:RDAVG](#) or [HOCR3:FAST](#) is changed, system software must wait at least 50µs before reading the corresponding holdover value from the HOFREQ[18:0] field.

Register Name: HOCR2
Register Description: Holdover Configuration Register 2
Register Address: 3Fh

	Bit 7	Bit 6	Bit 5	Bit 4	Bit 3	Bit 2	Bit 1	Bit 0
Name	HOFREQ[15:8]							
Default	0	0	0	0	0	0	0	0

Bits 7 to 0: Holdover Frequency (HOFREQ[15:8]). See the [HOCR1](#) register description.

Register Name: HOCR3
Register Description: Holdover Configuration Register 3
Register Address: 40h

	Bit 7	Bit 6	Bit 5	Bit 4	Bit 3	Bit 2	Bit 1	Bit 0
Name	AVG	FAST	RDAVG	MINIHO[1:0]		HOFREQ[18:16]		
Default	1	0	0	0	1	0	0	0

See Section 8.3 for important information about writing and reading this register.

Bit 7: Averaging (AVG). When this bit is set to 1 the T0 DPLL uses the averaged frequency value during holdover mode. When MANHO = 1 in the MCR3 register, this bit is ignored. See Section 7.7.1.6.

- 0 = Not averaged frequency; holdover frequency is either manual (MANHO = 1) or instantaneously frozen
- 1 = Averaged frequency (averaging rate set by the FAST bit below)

Bit 6: Fast Averaging (FAST). This bit controls the averaging rate used in the T0 DPLL's frequency averager. Fast averaging has a -3dB response point of approximately 8 minutes. Slow averaging has a -3dB response point of approximately 110 minutes. See Section 7.7.1.6.

- 0 = Slow frequency averaging
- 1 = Fast frequency averaging

Bit 5: Read Average (RDAVG). This bit controls which value is accessed when reading the HOFREQ field: the manual holdover frequency or the T0 DPLL's averaged frequency. This allows control software, optionally, to make use of the averager and manual holdover mode in a software-controlled holdover algorithm. See Section 7.7.1.6.

- 0 = Read the manual holdover frequency value previously written
- 1 = Read the averaged frequency

Bits 4 to 3: Miniholdover Mode (MINIHO). Miniholdover is the state of the T0 DPLL where it is in the locked state but has temporarily lost its input. In miniholdover the DPLL behaves exactly the same as in holdover but with holdover frequency selected as specified by this field. See Section 7.7.1.7.

- 00 = frequency determined in the same way as holdover mode
- 01 = frequency instantaneously frozen (i.e., as if AVG = 0)
- 10 = frequency taken from fast averager (i.e., as if AVG = 1 and FAST = 1)
- 11 = frequency taken from slow averager (i.e., as if AVG = 1 and FAST = 0)

Bits 2 to 0: Holdover Frequency (HOFREQ[18:16]). See the HOCR1 register description.

Register Name: DLIMIT1
Register Description: DPLL Frequency Limit Register 1
Register Address: 41h

	Bit 7	Bit 6	Bit 5	Bit 4	Bit 3	Bit 2	Bit 1	Bit 0
Name	HARDLIM[7:0]							
Default	0	1	1	1	0	1	1	0

The DLIMIT1 and DLIMIT2 registers must be read consecutively and written consecutively. See Section 8.3.

Bits 7 to 0: DPLL Hard Frequency Limit (HARDLIM[7:0]). The full 10-bit HARDLIM[9:0] field spans this register and DLIMIT2. HARDLIM is an unsigned integer that specifies the hard frequency limit or pull-in/hold-in range of the T0 DPLL. When frequency limit detection is enabled by setting FLLOL = 1 in the DLIMIT3 register, if the DPLL frequency exceeds the hard limit then the DPLL declares loss-of-lock. The hard frequency limit in ppm is $\pm \text{HARDLIM}[9:0] \times 0.078$. The default value is normally ± 9.2 ppm. If external reference switching mode is enabled during reset (see Section 7.6.5), the default value is configured to ± 79.794 ppm (3FFh). See Section 7.7.6.

Register Name: DLIMIT2
Register Description: DPLL Frequency Limit Register 2
Register Address: 42h

	Bit 7	Bit 6	Bit 5	Bit 4	Bit 3	Bit 2	Bit 1	Bit 0
Name	—	—	—	—	—	—	HARDLIM[9:8]	
Default	0	0	0	0	0	0	0	0

Bits 1 to 0: DPLL Hard Frequency Limit (HARDLIM[9:8]). See the DLIMIT1 register description.

Register Name: IER1
Register Description: Interrupt Enable Register 1
Register Address: 43h

	Bit 7	Bit 6	Bit 5	Bit 4	Bit 3	Bit 2	Bit 1	Bit 0
Name	IC8	IC7	IC6	IC5	IC4	IC3	IC2	IC1
Default	0	0	0	0	0	0	0	0

Bits 7 to 0: Interrupt Enable for Input Clock Status Change (IC8 to IC1). Each of these bits is an interrupt enable control for the corresponding bit in the [MSR1](#) register.

0 = Mask the interrupt

1 = Enable the interrupt

Register Name: IER2
Register Description: Interrupt Enable Register 2
Register Address: 44h

	Bit 7	Bit 6	Bit 5	Bit 4	Bit 3	Bit 2	Bit 1	Bit 0
Name	STATE	SRFAIL	IC14	IC13	IC12	IC11	IC10	IC9
Default	0	0	0	0	0	0	0	0

Bit 7: Interrupt Enable for T0 DPLL State Change (STATE). This bit is an interrupt enable for the STATE bit in the [MSR2](#) register.

0 = Mask the interrupt

1 = Enable the interrupt

Bit 6: Interrupt Enable for Selected Reference Failed (SRFAIL). This bit is an interrupt enable for the SRFAIL bit in the [MSR2](#) register.

0 = Mask the interrupt

1 = Enable the interrupt

Bits 5 to 0: Interrupt Enable for Input Clock Status Change (IC14 to IC9). Each of these bits is an interrupt enable control for the corresponding bit in the [MSR2](#) register.

0 = Mask the interrupt

1 = Enable the interrupt

Register Name: IER3
Register Description: Interrupt Enable Register 3
Register Address: 45h

	Bit 7	Bit 6	Bit 5	Bit 4	Bit 3	Bit 2	Bit 1	Bit 0
Name	FSMON	T4LOCK	PHMON	T4NOIN	AMI2	LOS2	AMI1	LOS1
Default	0	0	0	0	0	0	0	0

Bit 7: Interrupt Enable for Frame Sync Input Monitor Alarm (FSMON). This bit is an interrupt enable for the FSMON bit in the [MSR3](#) register.

- 0 = Mask the interrupt
- 1 = Enable the interrupt

Bit 6: Interrupt Enable for T4 DPLL Lock Status Change (T4LOCK). This bit is an interrupt enable for the T4LOCK bit in the [MSR3](#) register.

- 0 = Mask the interrupt
- 1 = Enable the interrupt

Bit 5: Interrupt Enable for Phase Monitor Alarm (PHMON). This bit is an interrupt enable for the PHMON bit in the [MSR3](#) register.

- 0 = Mask the interrupt
- 1 = Enable the interrupt

Bit 4: Interrupt Enable for T4 No Valid Inputs Alarm (T4NOIN). This bit is an interrupt enable for the T4NOIN bit in the [MSR3](#) register.

- 0 = Mask the interrupt
- 1 = Enable the interrupt

Bit 3: Interrupt Enable for AMI Violation on IC2 (AMI2). This bit is an interrupt enable for the AMI2 bit in the [MSR3](#) register.

- 0 = Mask the interrupt
- 1 = Enable the interrupt

Bit 2: Interrupt Enable for LOS Error on IC2 (LOS2). This bit is an interrupt enable for the LOS2 bit in the [MSR3](#) register.

- 0 = Mask the interrupt
- 1 = Enable the interrupt

Bit 1: Interrupt Enable for AMI Violation on IC1 (AMI1). This bit is an interrupt enable for the AMI1 bit in the [MSR3](#) register.

- 0 = Mask the interrupt
- 1 = Enable the interrupt

Bit 0: Interrupt Enable for LOS Error on IC1 (LOS1). This bit is an interrupt enable for the LOS1 bit in the [MSR3](#) register.

- 0 = Mask the interrupt
- 1 = Enable the interrupt

Register Name: DIVN1
Register Description: DIVN Register 1
Register Address: 46h

	Bit 7	Bit 6	Bit 5	Bit 4	Bit 3	Bit 2	Bit 1	Bit 0
Name	DIVN[7:0]							
Default	1	1	1	1	1	1	1	1

The DIVN1 and DIVN2 registers must be read consecutively and written consecutively. See Section 8.3.

Bits 7 to 0: DIVN Factor (DIVN[7:0]). The full 15-bit DIVN[14:0] field spans this register and [DIVN2](#). This field contains the integer value used to divide the frequency of input clocks that are configured for DIVN mode (DIVN = 1 in registers [ICR1](#) through [ICR14](#)). The frequency is divided by DIVN[14:0] + 1.

DIVN mode supports a maximum input frequency of 155.52MHz; therefore, the maximum value of DIVN[14:0] is 19,439 (i.e., 155.52MHz / 8kHz - 1). Performance with DIVN values greater than 19,439 is undefined. See Section 7.4.2.3.

Register Name: DIVN2
Register Description: DIVN Register 2
Register Address: 47h

	Bit 7	Bit 6	Bit 5	Bit 4	Bit 3	Bit 2	Bit 1	Bit 0
Name	—	DIVN[14:8]						
Default	0	0	1	1	1	1	1	1

Bits 5 to 0: DIVN Factor (DIVN [14:8]). See the [DIVN1](#) register description.

Register Name: MCR10
Register Description: Master Configuration Register 10
Register Address: 48h

	Bit 7	Bit 6	Bit 5	Bit 4	Bit 3	Bit 2	Bit 1	Bit 0
Name	FMONCLK	SRFPIN	UFSW	EXTSW	PBOFRZ	PBOEN	SOFTEN	HARDEN
Default	0	0	0	see below	0	1	0	1

Bit 7: Frequency Monitor Clock Source (FMONCLK). This bit specifies the clock source for the input clock frequency monitors.

- 0 = T0 DPLL output
- 1 = Internal master clock

Bit 6: SRFAIL Pin Enable (SRFPIN). When this bit is set to 1, the SRFAIL pin is enabled. When enabled the SRFAIL pin follows the state of the SRFAIL status bit in the [MSR2](#) register. This gives the system a very fast indication of the failure of the current reference. See Section [7.5.3](#).

- 0 = SRFAIL pin disabled (low)
- 1 = SRFAIL pin enabled

Bit 5: Ultra-Fast Switching Mode (UFSW). See Section [7.6.4](#).

- 0 = Disabled
- 1 = Enabled. The current reference source is disqualified after less than three missing clock cycles.

Bit 4: External Reference Switching Mode (EXTSW). This bit enables external reference switching mode. In this mode, if the SRCSW pin is high the T0 DPLL is forced to lock to input IC3 (if the priority of IC3 is nonzero) or IC5 (if the priority of IC3 is zero) whether or not the selected input has a valid reference signal. If the SRCSW pin is low the device is forced to lock to input IC4 (if the priority of IC4 is nonzero) or IC6 (if the priority of IC4 is zero) whether or not the selected input has a valid reference signal. During reset the default value of this bit is latched from the SRCSW pin. This mode only controls the T0 DPLL. The T4 DPLL is not affected. See Section [7.6.5](#).

- 0 = Normal operation
- 1 = External switching mode

Bit 3: Phase Build-Out Freeze (PBOFRZ). This bit freezes the current input-output phase relationship and does not allow further phase build-out events to occur. This bit affects phase build-out in response to input transients (Section [7.7.7.2](#)) and phase build-out during reference switching (Section [7.7.7.3](#)).

- 0 = Not frozen
- 1 = Frozen

Bit 2: Phase Build-Out Enable (PBOEN). When this bit is set to 1 a phase build-out event occurs every time the T0 DPLL changes to a new reference, including exiting the holdover and free-run states. When this bit is set to 0, the T0 DPLL locks to the new source with zero degrees of phase difference. See Section [7.7.7](#).

When the device is in slave mode (MASTSLV pin = 0) values written to this field are latched, but the value read is always 0 to indicate that the device is forced to have phase build-out disabled. See Section [7.9.1](#).

- 0 = Disabled
- 1 = Enabled

Bit 1: Soft Frequency Alarm Enable (SOFTEN). This bit enables input clock frequency monitoring with the soft alarm limits set in the [ILIMIT](#) and [SRLIMIT](#) registers. Soft alarms are reported in the SOFT status bits of the [ISR](#) registers. See Section [7.5.1](#).

- 0 = Disabled
- 1 = Enabled

Bit 0: Hard Frequency Limit Enable (HARDEN). This bit enables input clock frequency monitoring with the hard alarm limits set in the [ILIMIT](#) and [SRLIMIT](#) registers. Hard alarms are reported in the HARD status bits of the [ISR](#) registers. See Section [7.5.1](#).

- 0 = Disabled
- 1 = Enabled

Register Name: ILIMIT
Register Description: Input Clock Frequency Limit Register
Register Address: 49h

	Bit 7	Bit 6	Bit 5	Bit 4	Bit 3	Bit 2	Bit 1	Bit 0
Name	SOFT[3:0]				HARD[3:0]			
Default	0	0	1	0	0	0	1	1

Bits 7 to 4: Soft Frequency Alarm Limit (SOFT[3:0]). This field is an unsigned integer that specifies the soft frequency alarm limit for all input clocks except the T0 DPLL's selected reference. The soft limit for the selected reference is specified by [SRLIMIT:SOFT\[3:0\]](#). The soft alarm limit is only used for monitoring; soft alarms do not invalidate input clocks. The limit in ppm is $\pm(\text{SOFT}[3:0] + 1) \times 3.81$. The default limit is $\pm 11.43\text{ppm}$. Soft alarms are reported in the SOFT status bits of the [ISR](#) registers. See Section 7.5.1.

Bits 3 to 0: Hard Frequency Alarm Limit (HARD[3:0]). This field is an unsigned integer that specifies the hard frequency alarm limit for all input clocks except the T0 DPLL's selected reference. The hard limit for the selected reference is specified by [SRLIMIT:HARD\[3:0\]](#). Hard alarms invalidate input clocks. The limit in ppm is $\pm(\text{HARD}[3:0] + 1) \times 3.81$. The default limit is $\pm 15.24\text{ppm}$. Hard alarms are reported in the HARD status bits of the [ISR](#) registers. See Section 7.5.1.

Register Name: SRLIMIT
Register Description: Selected Reference Frequency Limit Register
Register Address: 4Ah

	Bit 7	Bit 6	Bit 5	Bit 4	Bit 3	Bit 2	Bit 1	Bit 0
Name	SOFT[3:0]				HARD[3:0]			
Default	0	0	1	0	0	0	1	1

Bits 7 to 4: Soft Frequency Alarm Limit (SOFT[3:0]). This field is an unsigned integer that specifies the soft frequency alarm limit for the T0 DPLL's selected reference. The soft limit for all other input clocks is specified by [ILIMIT:SOFT\[3:0\]](#). The soft alarm limit is only used for monitoring; soft alarms do not invalidate input clocks. The limit in ppm is $\pm(\text{SOFT}[3:0] + 1) \times 3.81$. The default limit is $\pm 11.43\text{ppm}$. Soft alarms are reported in the SOFT status bits of the [ISR](#) registers. See Section 7.5.1.

Bits 3 to 0: Hard Frequency Alarm Limit (HARD[3:0]). This field is an unsigned integer that specifies the hard frequency alarm limit for the T0 DPLL's selected reference. The hard limit for all other input clocks is specified by [ILIMIT:HARD\[3:0\]](#). Hard alarms invalidate input clocks. The limit in ppm is $\pm(\text{HARD}[3:0] + 1) \times 3.81$. The default limit is $\pm 15.24\text{ppm}$. Hard alarms are reported in the HARD status bits of the [ISR](#) registers. See Section 7.5.1.

Register Name: MCR11
Register Description: Master Configuration Register 11
Register Address: 4Bh

	Bit 7	Bit 6	Bit 5	Bit 4	Bit 3	Bit 2	Bit 1	Bit 0
Name	—	—	—	T4T0	FMEASIN[3:0]			
Default	0	0	0	0	0	0	0	0

Bit 4: T4 or T0 Path Select (T4T0). This bit specifies which path is being accessed when reads or writes are made to the following registers: [PTAB1](#), [PTAB2](#), [FREQ1](#), [FREQ2](#), [FREQ3](#), [IPR1](#) through [IPR7](#), [PHASE1](#) and [PHASE2](#).

- 0 = T0 path
- 1 = T4 path

Bits 3 to 0: Frequency Measurement Input Select (FMEASIN[3:0]). This field specifies the input clock for the frequency measurement reported in the [FMEAS](#) register. See Section 7.5.1.

- 0000 = {unused value}
- 0001 = IC1
- 0010 = IC2
- 0011 = IC3
- 0100 = IC4
- 0101 = IC5
- 0110 = IC6
- 0111 = IC7
- 1000 = IC8
- 1001 = IC9
- 1010 = IC10
- 1011 = IC11
- 1100 = IC12
- 1101 = IC13
- 1110 = IC14
- 1111 = {unused value}

Register Name: FMEAS
Register Description: Frequency Measurement Register
Register Address: 4Ch

	Bit 7	Bit 6	Bit 5	Bit 4	Bit 3	Bit 2	Bit 1	Bit 0
Name	FMEAS[7:0]							
Default	0	0	0	0	0	0	0	0

Bits 7 to 0: Measured Frequency (FMEAS[7:0]). This read-only field indicates the measured frequency of the input clock specified in the FMEASIN field of the [MCR11](#) register. FMEAS is a two's-complement signed integer that expresses the frequency as an offset with respect to the frequency monitor clock (either the internal master clock or the output of the T0 DPLL, depending on the setting of the FMONCLK bit in the [MCR10](#) register). The measured frequency is FMEAS[7:0] x 3.81ppm. See Section 7.5.1.

Register Name: DLIMIT3
Register Description: DPLL Frequency Limit Register 3
Register Address: 4Dh

	Bit 7	Bit 6	Bit 5	Bit 4	Bit 3	Bit 2	Bit 1	Bit 0
Name	FLLOL	SOFTLIM[6:0]						
Default	1	0	0	0	1	1	1	0

Bit 7: Frequency Limit Loss of Lock (FLLOL). When this bit is set to 1, the T0 and T4 DPLLs internally declare loss-of-lock when their hard limits are reached. The T0 DPLL hard frequency limit is set in the HARDLIM[9:0] field in the [DLIMIT1](#) and [DLIMIT2](#) registers. The T4 DPLL hard frequency limit is fixed at ± 80 ppm. See Section [7.7.6](#).

0 = DPLL declares loss-of-lock normally

1 = DPLL also declares loss-of-lock when the hard frequency limit is reached

Bits 6 to 0: DPLL Soft Frequency Limit (SOFTLIM6:0). This field is an unsigned integer that specifies the soft frequency limit for the T0 and T4 DPLLs. The soft limit is only used for monitoring; exceeding this limit does not cause loss-of-lock. The limit in ppm is $\pm \text{SOFTLIM}[6:0] \times 0.628$. The default value is ± 8.79 ppm. When the T0 DPLL frequency exceeds the soft limit the T0SOFT status bit is set in the [OPSTATE](#) register. When the T4 DPLL frequency exceeds the soft limit the T4SOFT status bit is set in [OPSTATE](#). See Section [7.7.6](#).

Register Name: IER4
Register Description: Interrupt Enable Register 4
Register Address: 4Eh

	Bit 7	Bit 6	Bit 5	Bit 4	Bit 3	Bit 2	Bit 1	Bit 0
Name	FHORDY	SHORDY	—	—	IC2NO4	IC1NO4	IC2NO8	IC1NO8
Default	0	0	0	0	0	0	0	0

Bit 7: Interrupt Enable for Fast Holdover Frequency Ready (FHORDY). This bit is an interrupt enable for the FHORDY bit in the [MSR4](#) register.

0 = Mask the interrupt

1 = Enable the interrupt

Bit 6: Interrupt Enable for Slow Holdover Frequency Ready (SHORDY). This bit is an interrupt enable for the SHORDY bit in the [MSR4](#) register.

0 = Mask the interrupt

1 = Enable the interrupt

Bit 3: Interrupt Enable for Input Clock 2 Has No 400Hz Component (IC2NO4). This bit is an interrupt enable for the IC2NO4 bit in the [MSR4](#) register.

0 = Mask the interrupt

1 = Enable the interrupt

Bit 2: Interrupt Enable for Input Clock 1 Has No 400Hz Component (IC1NO4). This bit is an interrupt enable for the IC1NO4 bit in the [MSR4](#) register.

0 = Mask the interrupt

1 = Enable the interrupt

Bit 1: Interrupt Enable for Input Clock 2 Has No 8kHz Component (IC2NO8). This bit is an interrupt enable for the IC2NO8 bit in the [MSR4](#) register.

0 = Mask the interrupt

1 = Enable the interrupt

Bit 0: Interrupt Enable for Input Clock 1 Has No 8kHz Component (IC1NO8). This bit is an interrupt enable for the IC1NO8 bit in the [MSR4](#) register.

0 = Mask the interrupt

1 = Enable the interrupt

Register Name: LB0U
Register Description: Leaky Bucket 0 Upper Threshold Register
Register Address: 50h

	Bit 7	Bit 6	Bit 5	Bit 4	Bit 3	Bit 2	Bit 1	Bit 0
Name	LB0U[7:0]							
Default	0	0	0	0	0	1	1	0

Bits 7 to 0: Leaky Bucket 0 Upper Threshold (LB0U[7:0]). When the leaky bucket accumulator is equal to the value stored in this field, the activity monitor declares an activity alarm by setting the input clock's ACT bit in the appropriate **ISR** register. Registers **LB0U**, **LB0L**, **LB0S**, and **LB0D** together specify leaky bucket configuration 0. See Section 7.5.2.

Register Name: LB0L
Register Description: Leaky Bucket 0 Lower Threshold Register
Register Address: 51h

	Bit 7	Bit 6	Bit 5	Bit 4	Bit 3	Bit 2	Bit 1	Bit 0
Name	LB0L[7:0]							
Default	0	0	0	0	0	1	0	0

Bits 7 to 0: Leaky Bucket 0 Lower Threshold (LB0L[7:0]). When the leaky bucket accumulator is equal to the value stored in this field, the activity monitoring logic clears the activity alarm (if previously declared) by clearing the input clock's ACT bit in the appropriate **ISR** register. Registers **LB0U**, **LB0L**, **LB0S**, and **LB0D** together specify leaky bucket configuration 0. See Section 7.5.2.

Register Name: LB0S
Register Description: Leaky Bucket 0 Size Register
Register Address: 52h

	Bit 7	Bit 6	Bit 5	Bit 4	Bit 3	Bit 2	Bit 1	Bit 0
Name	LB0S[7:0]							
Default	0	0	0	0	1	0	0	0

Bits 7 to 0: Leaky Bucket 0 Size (LB0S[7:0]). This field specifies the maximum value of the leaky bucket. The accumulator cannot increment past this value. Registers **LB0U**, **LB0L**, **LB0S**, and **LB0D** together specify leaky bucket configuration 0. See Section 7.5.2.

Register Name: LB0D
Register Description: Leaky Bucket 0 Decay Rate Register
Register Address: 53h

	Bit 7	Bit 6	Bit 5	Bit 4	Bit 3	Bit 2	Bit 1	Bit 0
Name	—	—	—	—	—	—	LB0D[1:0]	
Default	0	0	0	0	0	0	0	1

Bits 1 to 0: Leaky Bucket 0 Decay Rate (LB0D[1:0]). This field specifies the decay or “leak” rate of the leaky bucket accumulator. For each period of 1, 2, 4, or 8 128ms intervals in which no irregularities are detected on the input clock, the accumulator decrements by 1. Registers [LB0U](#), [LB0L](#), [LB0S](#), and [LB0D](#) together specify leaky bucket configuration 0. See Section [7.5.2](#).

00 = decrement every 128ms (8 units/second)

01 = decrement every 256ms (4 units/second)

10 = decrement every 512ms (2 units/second)

11 = decrement every 1024ms (1 unit/second)

Register Name: LB1U, LB2U, LB3U
Register Description: Leaky Bucket 1/2/3 Upper Threshold Register
Register Address: 54h, 58h, 5Ch

	Bit 7	Bit 6	Bit 5	Bit 4	Bit 3	Bit 2	Bit 1	Bit 0
Name	LBxU[7:0]							
Default	0	0	0	0	0	1	1	0

Bits 7 to 0: Leaky Bucket 'x' Upper Threshold (LBxU[7:0]). See the [LB0U](#) register description.

Registers [LB1U](#), [LB1L](#), [LB1S](#), and [LB1D](#) together specify leaky bucket configuration 1.

Registers [LB2U](#), [LB2L](#), [LB2S](#), and [LB2D](#) together specify leaky bucket configuration 2.

Registers [LB3U](#), [LB3L](#), [LB3S](#), and [LB3D](#) together specify leaky bucket configuration 3.

Register Name: LB1L, LB2L, LB3L
Register Description: Leaky Bucket 1/2/3 Lower Threshold Register
Register Address: 55h, 59h, 5Dh

	Bit 7	Bit 6	Bit 5	Bit 4	Bit 3	Bit 2	Bit 1	Bit 0
Name	LBxL[7:0]							
Default	0	0	0	0	0	1	0	0

Bits 7 to 0: Leaky Bucket 'x' Lower Threshold (LBxL[7:0]). See the [LB0L](#) register description.

Registers [LB1U](#), [LB1L](#), [LB1S](#), and [LB1D](#) together specify leaky bucket configuration 1.

Registers [LB2U](#), [LB2L](#), [LB2S](#), and [LB2D](#) together specify leaky bucket configuration 2.

Registers [LB3U](#), [LB3L](#), [LB3S](#), and [LB3D](#) together specify leaky bucket configuration 3.

Register Name: LB1S, LB2S, LB3S
Register Description: Leaky Bucket 1/2/3 Size Register
Register Address: 56h, 5Ah, 5Eh

	Bit 7	Bit 6	Bit 5	Bit 4	Bit 3	Bit 2	Bit 1	Bit 0
Name	LBxS[7:0]							
Default	0	0	0	0	1	0	0	0

Bits 7 to 0: Leaky Bucket 'x' Size (LBxS[7:0]). See the [LB0S](#) register description.

Registers [LB1U](#), [LB1L](#), [LB1S](#), and [LB1D](#) together specify leaky bucket configuration 1.

Registers [LB2U](#), [LB2L](#), [LB2S](#), and [LB2D](#) together specify leaky bucket configuration 2.

Registers [LB3U](#), [LB3L](#), [LB3S](#), and [LB3D](#) together specify leaky bucket configuration 3.

Register Name: LB1D, LB2D, LB3D
Register Description: Leaky Bucket 1/2/3 Decay Rate Register
Register Address: 57h, 5Bh, 5Fh

	Bit 7	Bit 6	Bit 5	Bit 4	Bit 3	Bit 2	Bit 1	Bit 0
Name	—	—	—	—	—	—	LBxD[1:0]	
Default	0	0	0	0	0	0	0	1

Bits 1 to 0: Leaky Bucket 'x' Decay Rate (LBxD[1:0]). See the [LB0D](#) register description.

Registers [LB1U](#), [LB1L](#), [LB1S](#), and [LB1D](#) together configure leaky bucket algorithm 1.

Registers [LB2U](#), [LB2L](#), [LB2S](#), and [LB2D](#) together configure leaky bucket algorithm 2.

Registers [LB3U](#), [LB3L](#), [LB3S](#), and [LB3D](#) together configure leaky bucket algorithm 3.

Register Name: OCR1
Register Description: Output Configuration Register 1
Register Address: 60h

	Bit 7	Bit 6	Bit 5	Bit 4	Bit 3	Bit 2	Bit 1	Bit 0
Name	OFREQ2[3:0]				OFREQ1[3:0]			
Default	1	0	0	0	0	1	0	1

Bits 7 to 4: Output Frequency of OC2 (OFREQ2[3:0]). This field specifies the frequency of output clock OC2. The frequencies of the T0 APLL and T4 APLL are configured in the [TOCR1](#) and [T4CR1](#) registers. The Digital1 and Digital2 frequencies are configured in the [MCR7](#) register. See Section [7.8.2.3](#). Note that if the T4 DPLL is configured for 62.5MHz ([T4CR1:T4FREQ](#) = 1001) and the T4 APLL is configured to lock to the T4 DPLL ([TOCR1:T4APT0](#) = 0), then OFREQ2 = 1100 specifies T4 APLL frequency divided by 10 to give an output frequency of 25MHz.

0000 = Output disabled (i.e., low)

0001 = 2kHz

0010 = 8kHz

0011 = Digital2 (see [Table 7-8](#))

0100 = Digital1 (see [Table 7-8](#))

0101 = T0 APLL frequency divided by 48

0110 = T0 APLL frequency divided by 16

0111 = T0 APLL frequency divided by 12

1000 = T0 APLL frequency divided by 8

1001 = T0 APLL frequency divided by 6

1010 = T0 APLL frequency divided by 4

1011 = T4 APLL frequency divided by 64

1100 = T4 APLL frequency divided by 48 (or by 10, see note above)

1101 = T4 APLL frequency divided by 16

1110 = T4 APLL frequency divided by 8

1111 = T4 APLL frequency divided by 4

Bits 3 to 0: Output Frequency of OC1 (OFREQ1[3:0]). This field specifies the frequency of output clock OC1. The frequencies of the T0 APLL and T4 APLL are configured in the [TOCR1](#) and [T4CR1](#) registers. The Digital1 and Digital2 frequencies are configured in the [MCR7](#) register. See Section [7.8.2.3](#). Note that if the T4 DPLL is configured for 62.5MHz ([T4CR1:T4FREQ](#) = 1001) and the T4 APLL is configured to lock to the T4 DPLL ([TOCR1:T4APT0](#) = 0), then OFREQ1 = 1100 specifies T4 APLL frequency divided by 10 to give an output frequency of 25MHz.

0000 = Output disabled (i.e., low)

0001 = 2kHz

0010 = 8kHz

0011 = Digital2 (see [Table 7-8](#))

0100 = Digital1 (see [Table 7-8](#))

0101 = T0 APLL frequency divided by 48

0110 = T0 APLL frequency divided by 16

0111 = T0 APLL frequency divided by 12

1000 = T0 APLL frequency divided by 8

1001 = T0 APLL frequency divided by 6

1010 = T0 APLL frequency divided by 4

1011 = T4 APLL frequency divided by 64

1100 = T4 APLL frequency divided by 48 (or by 10, see note above)

1101 = T4 APLL frequency divided by 16

1110 = T4 APLL frequency divided by 8

1111 = T4 APLL frequency divided by 4

Register Name: OCR2
Register Description: Output Configuration Register 2
Register Address: 61h

	Bit 7	Bit 6	Bit 5	Bit 4	Bit 3	Bit 2	Bit 1	Bit 0
Name	OFREQ4[3:0]				OFREQ3[3:0]			
Default	1	0	0	0	0	1	1	0

Bits 7 to 4: Output Frequency of OC4 (OFREQ4[3:0]). This field specifies the frequency of output clock OC4. The frequencies of the T0 APLL and T4 APLL are configured in the [TOCR1](#) and [T4CR1](#) registers. The Digital1 and Digital2 frequencies are configured in the [MCR7](#) register. See Section 7.8.2.3. Note that if the T4 DPLL is configured for 62.5MHz ([T4CR1:T4FREQ](#) = 1001) and the T4 APLL is configured to lock to the T4 DPLL ([TOCR1:T4APT0](#) = 0), then OFREQ4 = 1100 specifies T4 APLL frequency divided by 10 to give an output frequency of 25MHz.

0000 = Output disabled (i.e., low)

0001 = 2kHz

0010 = 8kHz

0011 = Digital2 (see [Table 7-8](#))

0100 = Digital1 (see [Table 7-8](#))

0101 = T0 APLL frequency divided by 48

0110 = T0 APLL frequency divided by 16

0111 = T0 APLL frequency divided by 12

1000 = T0 APLL frequency divided by 8

1001 = T0 APLL frequency divided by 6

1010 = T0 APLL frequency divided by 4

1011 = T4 APLL frequency divided by 2

1100 = T4 APLL frequency divided by 48 (or by 10, see note above)

1101 = T4 APLL frequency divided by 16

1110 = T4 APLL frequency divided by 8

1111 = T4 APLL frequency divided by 4

Bits 3 to 0: Output Frequency of OC3 (OFREQ3[3:0]). This field specifies the frequency of output clock OC3. The frequencies of the T0 APLL and T4 APLL are configured in the [TOCR1](#) and [T4CR1](#) registers. The Digital1 and Digital2 frequencies are configured in the [MCR7](#) register. See Section 7.8.2.3. Note that if the T4 DPLL is configured for 62.5MHz ([T4CR1:T4FREQ](#) = 1001) and the T4 APLL is configured to lock to the T4 DPLL ([TOCR1:T4APT0](#) = 0), then OFREQ3 = 1100 specifies T4 APLL frequency divided by 10 to give an output frequency of 25MHz.

0000 = Output disabled (i.e., low)

0001 = 2kHz

0010 = 8kHz

0011 = Digital2 (see [Table 7-8](#))

0100 = Digital1 (see [Table 7-8](#))

0101 = T0 APLL frequency divided by 48

0110 = T0 APLL frequency divided by 16

0111 = T0 APLL frequency divided by 12

1000 = T0 APLL frequency divided by 8

1001 = T0 APLL frequency divided by 6

1010 = T0 APLL frequency divided by 4

1011 = T4 APLL frequency divided by 64

1100 = T4 APLL frequency divided by 48 (or by 10, see note above)

1101 = T4 APLL frequency divided by 16

1110 = T4 APLL frequency divided by 8

1111 = T4 APLL frequency divided by 4

Register Name: OCR3
Register Description: Output Configuration Register 3
Register Address: 62h

	Bit 7	Bit 6	Bit 5	Bit 4	Bit 3	Bit 2	Bit 1	Bit 0
Name	OFREQ6[3:0]				OFREQ5[3:0]			
Default	1	0	0	0	1	0	1	0

Bits 7 to 4: Output Frequency of OC6 (OFREQ6[3:0]). This field specifies the frequency of output clock output OC6. The frequencies of the T0 APLL and T4 APLL are configured in the [TOCR1](#) and [T4CR1](#) registers. The Digital1 and Digital2 frequencies are configured in the [MCR7](#) register. See Section 7.8.2.3. Note that if the T4 DPLL is configured for 62.5MHz ([T4CR1:T4FREQ](#) = 1001) and the T4 APLL is configured to lock to the T4 DPLL ([TOCR1:T4APT0](#) = 0), then OFREQ6 = 1100 specifies T4 APLL frequency divided by 10 to give an output frequency of 25MHz.

- 0000 = Output disabled (i.e., low)
- 0001 = 2kHz
- 0010 = 8kHz
- 0011 = T0 APLL frequency divided by 2
- 0100 = Digital1 (see [Table 7-8](#))
- 0101 = T0 APLL frequency
- 0110 = T0 APLL frequency divided by 16
- 0111 = T0 APLL frequency divided by 12
- 1000 = T0 APLL frequency divided by 8
- 1001 = T0 APLL frequency divided by 6
- 1010 = T0 APLL frequency divided by 4
- 1011 = T4 APLL frequency divided by 64
- 1100 = T4 APLL frequency divided by 48 (or by 10, see note above)
- 1101 = T4 APLL frequency divided by 16
- 1110 = T4 APLL frequency divided by 8
- 1111 = T4 APLL frequency divided by 4

Bits 3 to 0: Output Frequency of OC5 (OFREQ5[3:0]). This field specifies the frequency of output clock OC5. The frequencies of the T0 APLL and T4 APLL are configured in the [TOCR1](#) and [T4CR1](#) registers. The Digital1 and Digital2 frequencies are configured in the [MCR7](#) register. See Section 7.8.2.3. Note that if the T4 DPLL is configured for 62.5MHz ([T4CR1:T4FREQ](#) = 1001) and the T4 APLL is configured to lock to the T4 DPLL ([TOCR1:T4APT0](#) = 0), then OFREQ5 = 1100 specifies T4 APLL frequency divided by 10 to give an output frequency of 25MHz.

- 0000 = Output disabled (i.e., low)
- 0001 = 2kHz
- 0010 = 8kHz
- 0011 = Digital2 (see [Table 7-8](#))
- 0100 = Digital1 (see [Table 7-8](#))
- 0101 = T0 APLL frequency divided by 48
- 0110 = T0 APLL frequency divided by 16
- 0111 = T0 APLL frequency divided by 12
- 1000 = T0 APLL frequency divided by 8
- 1001 = T0 APLL frequency divided by 6
- 1010 = T0 APLL frequency divided by 4
- 1011 = T4 APLL frequency divided by 2
- 1100 = T4 APLL frequency divided by 48 (or by 10, see note above)
- 1101 = T4 APLL frequency divided by 16
- 1110 = T4 APLL frequency divided by 8
- 1111 = T4 APLL frequency divided by 4

Register Name: OCR4
Register Description: Output Configuration Register 4
Register Address: 63h

	Bit 7	Bit 6	Bit 5	Bit 4	Bit 3	Bit 2	Bit 1	Bit 0
Name	OC11EN	OC10EN	OC9EN	OC8EN	OFREQ7[3:0]			
Default	1	1	1	1	0	1	1	0

Bit 7: OC11 Enable (OC11EN). This configuration bit enables the 2kHz output on OC11. See Section 7.8.2.5.
 0 = Disabled (low)
 1 = Enabled

Bit 6: OC10 Enable (OC10EN). This configuration bit enables the 8kHz output on OC10. See Section 7.8.2.5.
 0 = Disabled (low)
 1 = Enabled

Bit 5: OC9 Enable (OC9EN). This configuration bit enables the 1.544/2.048MHz output on OC9. See Section 7.8.2.4.
 0 = Disabled (low)
 1 = Enabled

Bit 4: OC8 Enable (OC8EN). This configuration bit enables OC8 to transmit a 64kHz composite clock signal. See Sections 7.8.2.4 and 7.11.2.
 0 = Disabled (high impedance)
 1 = Enabled

Bits 3 to 0: Output Frequency of OC7 (OFREQ7[3:0]). This field specifies the frequency of output clock output OC7. The frequencies of the T0 APLL and T4 APLL are configured in the T0CR1 and T4CR1 registers. The Digital1 and Digital2 frequencies are configured in the MCR7 register. See Section 7.8.2.3. Note that if the T4 DPLL is configured for 62.5MHz (T4CR1:T4FREQ = 1001) and the T4 APLL is configured to lock to the T4 DPLL (T0CR1:T4APT0 = 0), then OFREQ7 = 1100 sel specifies T4 APLL frequency divided by 10 to give an output frequency of 25MHz.

- 0000 = Output disabled (i.e., low)
- 0001 = 2kHz
- 0010 = 8kHz
- 0011 = Digital2 (see Table 7-8)
- 0100 = T0 APLL frequency divided by 2
- 0101 = T0 APLL frequency divided by 48
- 0110 = T0 APLL frequency divided by 16
- 0111 = T0 APLL frequency divided by 12
- 1000 = T0 APLL frequency divided by 8
- 1001 = T0 APLL frequency divided by 6
- 1010 = T0 APLL frequency divided by 4
- 1011 = T4 APLL frequency divided by 64
- 1100 = T4 APLL frequency divided by 48 (or by 10, see note above)
- 1101 = T4 APLL frequency divided by 16
- 1110 = T4 APLL frequency divided by 8
- 1111 = T4 APLL frequency divided by 4

Register Name: T4CR1
Register Description: T4 DPLL Configuration Register 1
Register Address: 64h

	Bit 7	Bit 6	Bit 5	Bit 4	Bit 3	Bit 2	Bit 1	Bit 0
Name	—	ASQUEL	OC8DUTY	OC9SON	T4FREQ[3:0]			
Default	0	0	0	see below	0	0	0	1

Bit 6: Auto-Squelch (ASQUEL). When outputs OC8 and OC9 are sourced from the T4 DPLL ($MCR4:OC89=0$), this configuration bit enables automatic squelching of OC8 and OC9 whenever T4 has no valid input references. When an output is squelched it is forced low. See Section 7.8.2.4.

0 = Disable automatic squelching

1 = Enable automatic squelching of OC8 and OC9 when T4 has no valid input references

Bit 5: OC8 Duty Cycle (OC8DUTY). See Section 7.11.2.

0 = 50% duty cycle

1 = 5/8 duty cycle

Bit 4: OC9 SONET/SDH (OC9SON). When $MCR4:OC89 = 0$, this bit controls the frequency of clock output OC9. When $OC89 = 1$, this bit ignored and the frequency of OC9 is controlled by the SONSDH bit in $MCR3$. During reset the default value of this bit is latched from the SONSDH pin. See Section 7.8.2.4.

0 = 2048kHz (SDH)

1 = 1544kHz (SONET)

Bits 3 to 0: T4 DPLL Frequency (T4FREQ[3:0]). This field configures the T4 DPLL frequency. The T4 DPLL frequency can affect the frequency of the T4 APLL, which in turn affects the available output frequencies on clock outputs OC1 to OC7 (see registers $OCR1$ to $OCR4$). Optionally the T4 DPLL can be disabled and the T4 APLL can be locked to the T0 DPLL (see the T4APT0 bit in the $T0CR1$ register). See Section 7.8.2.

	T4 DPLL FREQUENCY	T4 APLL FREQUENCY
0000 =	Disabled	Depends on state of T4APT0 in T0CR1 register
0001 =	77.76MHz	311.04MHz (4 x T4 DPLL)
0010 =	24.576MHz (12 x E1)	98.304MHz (4 x T4 DPLL)
0011 =	32.768MHz (16 x E1)	131.072MHz (4 x T4 DPLL)
0100 =	37.056MHz (24 x DS1)	148.224MHz (4 x T4 DPLL)
0101 =	24.704MHz (16 x DS1)	98.816MHz (4 x T4 DPLL)
0110 =	68.736MHz (2 x E3)	274.944MHz (4 x T4 DPLL)
0111 =	44.736MHz (DS3)	178.944MHz (4 x T4 DPLL)
1000 =	25.248MHz (4 x 6312 kHz)	100.992MHz (4 x T4 DPLL)
1001 =	62.500MHz (GbE ÷ 16)	250.000MHz (4 x T4 DPLL)
1010–1111 =	{unused values}	{unused values}

Register Name: T0CR1
Register Description: T0 DPLL Configuration Register 1
Register Address: 65h

	Bit 7	Bit 6	Bit 5	Bit 4	Bit 3	Bit 2	Bit 1	Bit 0
Name	T4MT0	T4APT0	T0FT4[2:0]			T0FREQ[2:0]		
Default	0	0	0	0	0	0	0	1

Bit 7: T4 Measure T0 Phase (T4MT0). When this bit is set to 1 the T4 path is disabled, and the T4 phase detector is configured to measure the phase difference between the selected T0 DPLL input clock and the selected T4 DPLL input clock. See Section 7.7.10.

- 0 = Normal operation for the T4 path
- 1 = Enable T4-measure-T0-phase mode

Bit 6: T4 APLL Source from T0 (T4APT0). When this bit is set to 1 the T4 output APLL locks to the T0 LF output DFS rather than the T4 forward DFS. The T0FT4[1:0] field (below) specifies the T0 DPLL frequency. See Section 7.8.2.

- 0 = T4 APLL locks to T4 DPLL
- 1 = T4 APLL locks to T0 DPLL

Bits 5 to 3: T0 Frequency to T4 APLL (T0FT4[2:0]). This field specifies the frequency provided from the T0 LF output DFS to the T4 output APLL when the T4APT0 bit is set to 1. This frequency can be different than the frequency specified by T0CR1:T0FREQ. Values not listed below are unused. See Section 7.8.2.

	T0 DPLL FREQUENCY	T4 APLL FREQUENCY
000 =	24.576MHz (12 x E1)	98.304MHz (4 x T0 DPLL)
010 =	32.768MHz (16 x E1)	131.072MHz (4 x T0 DPLL)
100 =	37.056MHz (24 x DS1)	148.224MHz (4 x T0 DPLL)
110 =	24.704MHz (16 x DS1)	98.816MHz (4 x T0 DPLL)
111 =	25.248MHz (4 x 6312 kHz)	100.992MHz (4 x T0 DPLL)

Bits 2 to 0: T0 DPLL Frequency (T0FREQ[2:0]). This field configures the T0 DPLL output frequency that is passed to the T0 Output APLL. The T0 DPLL output frequency affects the frequency of the T0 Output APLL, which in turn affects the available output frequencies on clock outputs OC1 to OC7 (see registers OCR1 to OCR4). See Section 7.8.2.

	T0 DPLL FREQUENCY	T0 APLL FREQUENCY
000 =	77.76MHz, digital feedback	311.04MHz (4 x T0 DPLL)
001 =	77.76MHz, analog feedback	311.04MHz (4 x T0 DPLL)
010 =	24.576MHz (12 x E1)	98.304MHz (4 x T0 DPLL)
011 =	32.768MHz (16 x E1)	131.072MHz (4 x T0 DPLL)
100 =	37.056MHz (24 x DS1)	148.224MHz (4 x T0 DPLL)
101 =	24.704MHz (16 x DS1)	98.816MHz (4 x T0 DPLL)
110 =	25.248MHz (4 x 6312 kHz)	100.992MHz (4 x T0 DPLL)
111 =	{unused value}	{unused value}

Register Name: T4BW
Register Description: T4 Bandwidth Register
Register Address: 66h

	Bit 7	Bit 6	Bit 5	Bit 4	Bit 3	Bit 2	Bit 1	Bit 0
Name	—	—	—	—	—	—	T4BW[1:0]	
Default	0	0	0	0	0	0	0	0

Bits 1 to 0: T4 DPLL Bandwidth (T4BW[1:0]). See Section 7.7.3.

00 = 18 Hz
 01 = 35 Hz
 10 = 70 Hz
 11 = {unused value}

Register Name: T0LBW
Register Description: T0 Locked Bandwidth Register
Register Address: 67h

	Bit 7	Bit 6	Bit 5	Bit 4	Bit 3	Bit 2	Bit 1	Bit 0
Name	—	—	—	T0LBW[4:0]				
Default	0	0	0	0	1	0	1	1

Bits 4 to 0: T0 DPLL Locked Bandwidth (T0LBW[4:0]). This field configures the bandwidth of the T0 DPLL when locked to an input clock. When AUTOBW=0 in the MCR9 register, the T0LBW bandwidth is used for acquisition and for locked operation. When AUTOBW=1, TOABW bandwidth is used for acquisition while T0LBW bandwidth is used for locked operation. See Section 7.7.3.

00000 = 0.5 mHz
 00001 = 1 mHz
 00010 = 2 mHz
 00011 = 4 mHz
 00100 = 8 mHz
 00101 = 15 mHz
 00110 = 30 mHz
 00111 = 60 mHz
 01000 = 0.1 Hz
 01001 = 0.3 Hz
 01010 = 0.6 Hz
 01011 = 1.2 Hz
 01100 = 2.5 Hz
 01101 = 4 Hz
 01110 = 8 Hz
 01111 = 18 Hz
 10000 = 35 Hz
 10001 = 70 Hz
 10010 to 11111 = {unused values}

Register Name: T0ABW
Register Description: T0 Acquisition Bandwidth Register
Register Address: 69h

	Bit 7	Bit 6	Bit 5	Bit 4	Bit 3	Bit 2	Bit 1	Bit 0
Name	—	—	—	T0ABW[4:0]				
Default	0	0	0	0	1	1	1	1

Bits 4 to 0: T0 DPLL Acquisition Bandwidth (T0ABW[4:0]). This field configures the bandwidth of the T0 DPLL when acquiring lock. When AUTOBW=0 in the [MCR9](#) register, the T0LBW bandwidth is used for acquisition and for locked operation. When AUTOBW=1, [T0ABW](#) bandwidth is used for acquisition while T0LBW bandwidth is used for locked operation. See Section [7.7.3](#).

00000 = 0.5 mHz

00001 = 1 mHz

00010 = 2 mHz

00011 = 4 mHz

00100 = 8 mHz

00101 = 15 mHz

00110 = 30 mHz

00111 = 60 mHz

01000 = 0.1 Hz

01001 = 0.3 Hz

01010 = 0.6 Hz

01011 = 1.2 Hz

01100 = 2.5 Hz

01101 = 4 Hz

01110 = 8 Hz

01111 = 18 Hz

10000 = 35 Hz

10001 = 70 Hz

10010 to 11111 = {unused values}

Register Name: T4CR2
Register Description: T4 Configuration Register 2
Register Address: 6Ah

	Bit 7	Bit 6	Bit 5	Bit 4	Bit 3	Bit 2	Bit 1	Bit 0
Name	—	PD2GA8K[2:0]			—	DAMP[2:0]		
Default	0	0	0	1	0	0	1	1

Bits 6 to 4: Phase Detector 2 Gain, Analog Feedback, 8 kHz (PD2GA8K[2:0]). This field specifies the gain of the T4 phase detector 2 in analog feedback mode with an input clock of 8 kHz or less. This value is only used if automatic gain selection is enabled by setting PD2EN=1 in the [T4CR3](#) register. Analog vs. digital feedback mode is specified in [MCR4:T4DFB](#). See Section [7.7.5](#).

Bits 2 to 0: Damping Factor (DAMP[2:0]). This field configures the damping factor of the T4 DPLL. Damping factor is a function of both DAMP[2:0] and the T4 DPLL bandwidth ([T4BW](#) register). The default value corresponds to a damping factor of 5. See Section [7.7.4](#).

	<u>18 Hz</u>	<u>35 Hz</u>	<u>70 Hz</u>
001 =	1.2	1.2	1.2
010 =	2.5	2.5	2.5
011 =	5	5	5
100 =	5	10	10
101 =	5	10	20

000, 110 and 111 = {unused values}

The gain peak for each damping factor is shown below:

<u>Damping Factor</u>	<u>Gain Peak</u>
1.2	0.4 dB
2.5	0.2 dB
5	0.1 dB
10	0.06 dB
20	0.03 dB

Register Name: T0CR2
Register Description: T0 Configuration Register 2
Register Address: 6Bh

	Bit 7	Bit 6	Bit 5	Bit 4	Bit 3	Bit 2	Bit 1	Bit 0
Name	—	PD2GA8K[2:0]			—	DAMP[2:0]		
Default	0	0	0	1	0	0	1	1

Bits 6 to 4: Phase Detector 2 Gain, Analog Feedback, 8 kHz (PD2GA8K[2:0]). This field specifies the gain of the T0 phase detector 2 in analog feedback mode with an input clock of 8 kHz or less. This value is only used if automatic gain selection is enabled by setting PD2EN=1 in the [T0CR3](#) register. Analog vs. digital feedback mode is specified in [T0CR1:T0FREQ\[2:0\]](#). See Section [7.7.5](#).

Bits 2 to 0: Damping Factor (DAMP[2:0]). This field configures the damping factor of the T0 DPLL. Damping factor is a function of both DAMP[2:0] and the T0 DPLL bandwidth ([T0ABW](#) and [T0LBW](#)). The default value corresponds to a damping factor of 5. See Section [7.7.4](#).

	<u>≤ 4 Hz</u>	<u>8 Hz</u>	<u>18 Hz</u>	<u>35 Hz</u>	<u>70 Hz</u>
001 =	5	2.5	1.2	1.2	1.2
010 =	5	5	2.5	2.5	2.5
011 =	5	5	5	5	5
100 =	5	5	5	10	10
101 =	5	5	5	10	20

000, 110 and 111 = {unused values}

The gain peak for each damping factor is shown below:

<u>Damping Factor</u>	<u>Gain Peak</u>
1.2	0.4 dB
2.5	0.2 dB
5	0.1 dB
10	0.06 dB
20	0.03 dB

Register Name: T4CR3
Register Description: T4 Configuration Register 3
Register Address: 6Ch

	Bit 7	Bit 6	Bit 5	Bit 4	Bit 3	Bit 2	Bit 1	Bit 0
Name	PD2EN	PD2GA[2:0]			—	PD2GD[2:0]		
Default	1	1	0	0	0	0	1	0

Bit 7: Phase Detector 2 Gain Enable (PD2EN). When this bit is set to 1, the T4 phase detector 2 is enabled and the gain is determined by the feedback mode. In digital feedback mode, the gain is set by the PD2GD field. In analog feedback mode the gain is set by the PD2GA field if the input clock frequency is greater than 8 kHz or by the PD2GA8K field in the [T4CR2](#) register if the input clock frequency is less than or equal to 8 kHz. Analog vs. digital feedback mode is specified in [MCR4:T4DFB](#). See Section [7.7.5](#).

0 = Disable

1 = Enable

Bits 6 to 4: Phase Detector 2 Gain, Analog Feedback (PD2GA[2:0]). This field specifies the gain of the T4 phase detector 2 in analog feedback mode with an input clock frequency greater than 8 kHz. This value is only used if automatic gain selection is enabled by setting PD2EN=1. Analog vs. digital feedback mode is specified in [MCR4:T4DFB](#). See Section [7.7.5](#).

Bits 2 to 0: Phase Detector 2 Gain, Digital Feedback (PD2GD[2:0]). This field specifies the gain of the T4 phase detector 2 in digital feedback mode. This value is only used if automatic gain selection is enabled by setting PD2EN=1. Analog vs. digital feedback mode is specified in [MCR4:T4DFB](#). See Section [7.7.5](#).

Register Name: T0CR3
Register Description: T0 Configuration Register 3
Register Address: 6Dh

	Bit 7	Bit 6	Bit 5	Bit 4	Bit 3	Bit 2	Bit 1	Bit 0
Name	PD2EN	PD2GA[2:0]			—	PD2GD[2:0]		
Default	1	1	0	0	0	0	1	0

Bit 7: Phase Detector 2 Gain Enable (PD2EN). When this bit is set to 1, the T0 phase detector 2 is enabled and the gain is determined by the feedback mode. In digital feedback mode, the gain is set by the PD2GD field. In analog feedback mode the gain is set by the PD2GA field if the input clock is greater than 8 kHz or by the PD2GA8K field in the [T0CR2](#) register if the input clock frequency is less than or equal to 8 kHz. Analog vs. digital feedback mode is specified in [T0CR1:T0FREQ\[2:0\]](#). See Section [7.7.5](#).

0 = Disable

1 = Enable

Bits 6 to 4: Phase Detector 2 Gain, Analog Feedback (PD2GA[2:0]). This field specifies the gain of the T0 phase detector 2 in analog feedback mode with an input clock frequency greater than 8 kHz. This value is only used if automatic gain selection is enabled by setting PD2EN=1. Analog vs. digital feedback mode is specified in [T0CR1:T0FREQ\[2:0\]](#). See Section [7.7.5](#).

Bits 2 to 0: Phase Detector 2 Gain, Digital Feedback (PD2GD[2:0]). This field specifies the gain of the T0 phase detector 2 in digital feedback mode. This value is only used if automatic gain selection is enabled by setting PD2EN=1. Analog vs. digital feedback mode is specified in [T0CR1:T0FREQ\[2:0\]](#). See Section [7.7.5](#).

Register Name: GPCR
Register Description: GPIO Configuration Register
Register Address: 6Eh

	Bit 7	Bit 6	Bit 5	Bit 4	Bit 3	Bit 2	Bit 1	Bit 0
Name	GPIO4D	GPIO3D	GPIO2D	GPIO1D	GPIO4O	GPIO3O	GPIO2O	GPIO1O
Default	0	0	0	0	0	0	0	0

Bit 7: GPIO4 Direction (GPIO4D). This bit configures the data direction for the GPIO4 pin. When GPIO4 is an input its current state can be read from [GPSR:GPIO4](#). When GPIO4 is an output, its value is controlled by the GPIO4O configuration bit.

0 = Input
 1 = Output

Bit 6: GPIO3 Direction (GPIO3D). This bit configures the data direction for the GPIO3 pin. When GPIO3 is an input its current state can be read from [GPSR:GPIO3](#). When GPIO3 is an output, its value is controlled by the GPIO3O configuration bit.

0 = Input
 1 = Output

Bit 5: GPIO2 Direction (GPIO2D). This bit configures the data direction for the GPIO2 pin. When GPIO2 is an input its current state can be read from [GPSR:GPIO2](#). When GPIO2 is an output, its value is controlled by the GPIO2O configuration bit.

0 = Input
 1 = Output

Bit 4: GPIO1 Direction (GPIO1D). This bit configures the data direction for the GPIO1 pin. When GPIO1 is an input its current state can be read from [GPSR:GPIO1](#). When GPIO1 is an output, its value is controlled by the GPIO1O configuration bit.

0 = Input
 1 = Output

Bit 3: GPIO4 Output Value (GPIO4O). When GPIO4 is configured as an output (GPIO4D=1) then this bit specifies the output value.

0 = Low
 1 = High

Bit 2: GPIO3 Output Value (GPIO3O). When GPIO3 is configured as an output (GPIO3D=1) then this bit specifies the output value.

0 = Low
 1 = High

Bit 1: GPIO2 Output Value (GPIO2O). When GPIO2 is configured as an output (GPIO2D=1) then this bit specifies the output value.

0 = Low
 1 = High

Bit 0: GPIO1 Output Value (GPIO1O). When GPIO1 is configured as an output (GPIO1D=1) then this bit specifies the output value.

0 = Low
 1 = High

Register Name: GPSR
Register Description: GPIO Status Register
Register Address: 6Fh

	Bit 7	Bit 6	Bit 5	Bit 4	Bit 3	Bit 2	Bit 1	Bit 0
Name	—	—	—	—	GPIO4	GPIO3	GPIO2	GPIO1
Default	0	0	0	0	0	0	0	0

Bit 3: GPIO4 State (GPIO4). This bit indicates the current state of the GPIO4 pin.

0 = low

1 = high

Bit 2: GPIO3 State (GPIO3). This bit indicates the current state of the GPIO3 pin.

0 = low

1 = high

Bit 2: GPIO2 State (GPIO2). This bit indicates the current state of the GPIO2 pin.

0 = low

1 = high

Bit 1: GPIO1 State (GPIO1). This bit indicates the current state of the GPIO1 pin.

0 = low

1 = high

Register Name: OFFSET1
Register Description: Phase Offset Register 1
Register Address: 70h

	Bit 7	Bit 6	Bit 5	Bit 4	Bit 3	Bit 2	Bit 1	Bit 0
Name	OFFSET[7:0]							
Default	0	0	0	0	0	0	0	0

The OFFSET1 and OFFSET2 registers must be read consecutively and written consecutively. See Section 8.3.

Bits 7 to 0: Phase Offset (OFFSET[7:0]). The full 16-bit OFFSET[15:0] field spans this register and the [OFFSET2](#) register. OFFSET is a 2's-complement signed integer that specifies the desired phase offset between the output clocks and the selected reference. The phase offset in picoseconds is equal to $\text{OFFSET}[15:0] * \text{actual_internal_clock_period} / 2^{11}$. If the internal clock is at its nominal frequency of 77.76 MHz then the phase offset equation simplifies to $\text{OFFSET}[15:0] * 6.279 \text{ ps}$. If, however, the DPLL is locked to a reference whose frequency is +1 ppm from ideal, for example, then the actual internal clock period is 1 ppm shorter and the phase offset is 1 ppm smaller. When the OFFSET field is written, the phase of the output clocks is automatically ramped to the new offset value to avoid loss of synchronization. To adjust the phase offset without changing the phase of the output clocks, use the recalibration process enabled by [FSCR3:RECAL](#). The OFFSET field is ignored when phase build-out is enabled (PBOEN=1 in the [MCR10](#) register or PMPBEN=1 in the [PHMON](#) register) and when the DPLL is not locked. See Section 7.7.8.

Register Name: OFFSET2
Register Description: Phase Offset Register 2
Register Address: 71h

	Bit 7	Bit 6	Bit 5	Bit 4	Bit 3	Bit 2	Bit 1	Bit 0
Name	OFFSET[15:8]							
Default	0	0	0	0	0	0	0	0

Bits 7 to 0: Phase Offset (OFFSET[15:8]). See the [OFFSET1](#) register description.

Register Name: PBOFF
Register Description: Phase Build-Out Offset Register
Register Address: 72h

	Bit 7	Bit 6	Bit 5	Bit 4	Bit 3	Bit 2	Bit 1	Bit 0
Name	—	—	PBOFF[5:0]					
Default	0	0	0	0	0	0	0	0

Bits 5 to 0: Phase Build-Out Offset Register (PBOFF[5:0]). An uncertainty of up to 5 ns is introduced each time a phase build-out event occurs. This uncertainty results in a phase hit on the output. Over a large number of phase build-out events the mean error should be zero. The PBOFF field specifies a fixed offset for each phase build-out event to skew the average error toward zero. This field is a 2's complement signed integer. The offset in nanoseconds is $PBOFF[5:0] * 0.101$. Values greater than 1.4 ns or less than -1.4 ns may cause internal math errors and should not be used. See Section 7.7.7.5.

Register Name: PHLIM1
Register Description: Phase Limit Register 1
Register Address: 73h

	Bit 7	Bit 6	Bit 5	Bit 4	Bit 3	Bit 2	Bit 1	Bit 0
Name	FLEN	NALOL	1	—	—	FINELIM[2:0]		
Default	1	0	1	0	0	0	1	0

Bit 7: Fine Phase Limit Enable (FLEN). This configuration bit enables the fine phase limit specified in the FINELIM[2:0] field. The fine limit must be disabled for multi-UI jitter tolerance (see PHLIM2 fields). This field controls both T0 and T4. See Section 7.7.6.

0 = Disabled
 1 = Enabled

Bit 6: No-Activity Loss of Lock (NALOL). The T0 and T4 DPLLs can detect that an input clock has no activity very quickly (within two clock cycles). When NALOL=0, loss-of-lock is not declared when clock cycles are missing, and nearest edge locking ($\pm 180^\circ$) is used when the clock recovers. This gives tolerance to missing cycles. When NALOL=1, loss-of-lock is indicated as soon as no activity is detected, and the device switches to phase/frequency locking ($\pm 360^\circ$). This field controls both T0 and T4. See Sections 7.5.3 and 7.7.6.

0 = No activity does not trigger loss-of-lock
 1 = No activity does trigger loss-of-lock

Bit 5: Leave set to 1 (test control).

Bits 2 to 0: Fine Phase Limit (FINELIM[2:0]). This field specifies the fine phase limit window, outside of which loss-of-lock is declared. The FLEN bit enables this feature. The phase of the input clock has to be inside the fine limit window for two seconds before phase lock is declared. Loss-of-lock is declared immediately if the phase of the input clock is outside the phase limit window. The default value of 010 is appropriate for most situations. This field controls both T0 and T4. See Section 7.7.6.

000 = Always indicates loss of phase lock—do not use
 001 = Small phase limit window, ± 45 to $\pm 90^\circ$
 010 = Normal phase limit window, ± 90 to $\pm 180^\circ$ (default)
 100, 101, 110, 111 = Proportionately larger phase limit window

Register Name: PHLIM2
Register Description: Phase Limit Register 2
Register Address: 74h

	Bit 7	Bit 6	Bit 5	Bit 4	Bit 3	Bit 2	Bit 1	Bit 0
Name	CLEN	MCPDEN	USEMCPD	—	COARSELIM[3:0]			
Default	1	0	0	0	0	1	0	1

Bit 7: Coarse Phase Limit Enable (CLEN). This configuration bit enables the coarse phase limit specified in the COARSELIM[3:0] field. This field controls both T0 and T4. See Section 7.7.6.

0 = Disabled
 1 = Enabled

Bit 6: Multi-Cycle Phase Detector Enable (MCPDEN). This configuration bit enables the multi-cycle phase detector and allows the DPLL to tolerate large-amplitude jitter and wander. The range of this phase detector is the same as the coarse phase limit specified in the COARSELIM[3:0] field. This field controls both T0 and T4. See Section 7.7.5.

0 = Disabled
 1 = Enabled

Bit 5: Use Multi-Cycle Phase Detector in the DPLL Algorithm (USEMCPD). This configuration bit enables the DPLL algorithm to use the multi-cycle phase detector so that a large phase measurement drives faster DPLL pull-in. When USEMCPD=0, phase measurement is limited to $\pm 360^\circ$, giving slower pull-in at higher frequencies but with less overshoot. When USEMCPD=1, phase measurement is set as specified in the COARSELIM[3:0] field, giving faster pull-in. MCPDEN should be set to 1 when USEMCPD=1. This field controls both T0 and T4. See Section 7.7.5.

0 = Disabled
 1 = Enabled

Bits 3 to 0: Coarse Phase Limit (COARSELIM[3:0]). This field specifies the coarse phase limit and the tracking range of the multi-cycle phase detector. The CLEN bit enables this feature. If jitter tolerance greater than 0.5 UI is required and the input clock is a high frequency signal then the DPLL can be configured to track phase errors over many UI using the multi-cycle phase detector. This field controls both T0 and T4. See Section 7.7.5 and 7.7.6.

0000 = ± 1 UI
 0001 = ± 3 UI
 0010 = ± 7 UI
 0011 = ± 15 UI
 0100 = ± 31 UI
 0101 = ± 63 UI
 0110 = ± 127 UI
 0111 = ± 255 UI
 1000 = ± 511 UI
 1001 = ± 1023 UI
 1010 = ± 2047 UI
 1011 = ± 4095 UI
 1100 to 1111 = ± 8191 UI

Register Name: PHMON
Register Description: Phase Monitor Register
Register Address: 76h

	Bit 7	Bit 6	Bit 5	Bit 4	Bit 3	Bit 2	Bit 1	Bit 0
Name	NW	—	PMEN	PMPBEN	PMLIM[3:0]			
Default	0	0	0	0	0	1	1	0

Bit 7: Low-Frequency Input Clock Noise Window (NW). For 2 kHz, 4 kHz or 8 kHz input clocks, this configuration bit enables a $\pm 5\%$ tolerance noise window centered around the expected clock edge location. Noise-induced edges outside this window are ignored, reducing the possibility of phase hits on the output clocks. NW should be enabled only when the device is locked to an input and [TEST1:D180=0](#).

0 = All edges are recognized by the DPLL

1 = Only edges within the $\pm 5\%$ tolerance window are recognized by the DPLL

Bit 5: Phase Monitor Enable (PMEN). This configuration bit enables the phase monitor, which measures the phase error between the input clock reference and the DPLL output. When the DPLL is set for low bandwidth, a phase transient on the input causes an immediate phase error that is gradually reduced as the DPLL tracks the input. When the measured phase error exceeds the limit set in the PMLIM field, the phase monitor declares a phase monitor alarm by setting [MSR3:PHMON](#). See Section [7.7.7](#).

0 = Disabled

1 = Enabled

Bit 4: Phase Monitor to Phase Build-Out Enable (PMPBEN). This bit enables phase build-out in response to phase hits on the selected reference. See Section [7.7.7](#).

0 = Phase monitor alarm does not trigger a phase build-out event

1 = Phase monitor alarm does trigger a phase build-out event

Bits 3 to 0: Phase Monitor Limit (PMLIM[3:0]). This field is an unsigned integer that specifies the magnitude of phase error that causes a phase monitor alarm to be declared (PHMON bit in the [MSR3](#) register). The phase monitor limit in nanoseconds is equal to $(PMLIM[3:0] + 7) * 156.25$, which corresponds to a range of 1094 ns to 3437 ns in 156.25 ns steps. The phase monitor is enabled by setting PMEN=1. See Section [7.7.7](#).

Register Name: PHASE1
Register Description: Phase Register 1
Register Address: 77h

	Bit 7	Bit 6	Bit 5	Bit 4	Bit 3	Bit 2	Bit 1	Bit 0
Name	PHASE[7:0]							
Default	0	0	0	0	0	0	0	0

The PHASE1 and PHASE2 registers must be read consecutively. See Section 8.3.

Bits 7 to 0: Current DPLL Phase (PHASE[7:0]). The full 16-bit PHASE[15:0] field spans this register and the PHASE2 register. PHASE is a 2's-complement signed integer that indicates the current value of the phase detector. The value is the output of the phase averager. When T4T0=0 in the MCR11 register, PHASE indicates the current phase of the T0 DPLL. When T4T0=1, PHASE indicates the current phase of the T4 DPLL. The averaged phase difference in degrees is equal to PHASE * 0.707. See Section 7.7.10.

Register Name: PHASE2
Register Description: Phase Register 2
Register Address: 78h

	Bit 7	Bit 6	Bit 5	Bit 4	Bit 3	Bit 2	Bit 1	Bit 0
Name	PHASE[15:8]							
Default	0	0	0	0	0	0	0	0

Bits 7 to 0: Current DPLL Phase (PHASE[15:8]). See the PHASE1 register description.

Register Name: PHLKTO
Register Description: Phase Lock Timeout Register
Register Address: 79h

	Bit 7	Bit 6	Bit 5	Bit 4	Bit 3	Bit 2	Bit 1	Bit 0
Name	PHLKTOM[1:0]		PHLKTO[5:0]					
Default	0	0	1	1	0	0	1	0

Bits 7 to 6: Phase Lock Timeout Multiplier (PHLKTOM[1:0]). This field is an unsigned integer that specifies the resolution of the phase lock timeout field PHLKTO[5:0].

- 00 = 2 seconds
- 01 = 4 seconds
- 10 = 8 seconds
- 11 = 16 seconds

Bits 5 to 0: Phase Lock Timeout (PHLKTO[5:0]). This field is an unsigned integer that, together with the PHLKTOM[1:0] field, specifies the length of time that the T0 DPLL attempts to lock to an input clock before declaring a phase lock alarm (by setting the corresponding LOCK bit in the ISR registers). The timeout period in seconds is $PHLKTO[5:0] * 2^{(PHLKTOM[1:0]+1)}$. The state machine remains in the Pre-locked, Pre-locked 2 or Phase-lost modes for the specified time before declaring a phase alarm on the selected input. See Section 7.7.1.

Register Name: FSCR1
Register Description: Frame Sync Configuration Register 1
Register Address: 7Ah

	Bit 7	Bit 6	Bit 5	Bit 4	Bit 3	Bit 2	Bit 1	Bit 0
Name	2K8KSRC	—	—	—	8KINV	8KPUL	2KINV	2KPUL
Default	0	0	0	0	0	0	0	0

Bit 7: 2 kHz / 8kHz Source (2K8KSRC). This configuration bit specifies the source for the 2 kHz and 8 kHz outputs available on clock outputs OC1 through OC7. See Section 7.8.2.3.

0 = T0 DPLL

1 = T4 DPLL

Bit 3: 8 kHz Invert (8KINV). When this bit is set to 1 the 8 kHz signal on clock output OC10 is inverted. See Section 7.8.2.5.

0 = OC10 not inverted

1 = OC10 inverted

Bit 2: 8 kHz Pulse (8KPUL). When this bit is set to 1, the 8 kHz signal on clock output OC10 is pulsed rather than 50% duty cycle. In this mode output clock OC3 must be enabled, and the pulse width of OC10 is equal to the clock period of OC3. See Section 7.8.2.5.

0 = OC10 not pulsed; 50% duty cycle

1 = OC10 pulsed, with pulse width equal to OC3 period

Bit 1: 2 kHz Invert (2KINV). When this bit is set to 1 the 2 kHz signal on clock output OC11 is inverted. See Section 7.8.2.5.

0 = OC11 not inverted

1 = OC11 inverted

Bit 0: 2 kHz Pulse (2KPUL). When this bit is set to 1, the 2 kHz signal on clock output OC11 is pulsed rather than 50% duty cycle. In this mode output clock OC3 must be enabled, and the pulse width of OC11 is equal to the clock period of OC3. See Section 7.8.2.5.

0 = OC11 not pulsed; 50% duty cycle

1 = OC11 pulsed, with pulse width equal to OC3 period

Register Name: FSCR2
Register Description: Frame Sync Configuration Register 2
Register Address: 7Bh

	Bit 7	Bit 6	Bit 5	Bit 4	Bit 3	Bit 2	Bit 1	Bit 0
Name	INDEP	OCN	—	—	—	—	PHASE[1:0]	
Default	0	0	0	0	0	0	0	0

Bit 7: Independent Frame Sync and Multi-frame Sync (INDEP). When this bit is set to 0, the 8 kHz frame sync on OC10 and the 2 kHz multi-frame sync on OC11 are aligned with the other output clocks when synchronized with the SYNC2K input. When this bit is 1, the frame sync and multi-frame sync are independent of the other output clocks, and their edge position may change without disturbing the other output clocks. See Section 7.9.3.

0 = OC10 and OC11 are aligned with other output clocks; all are synchronized by the SYNC2K input

1 = OC10 and OC11 are independent of the other clock outputs; only OC10 and OC11 are synchronized by the SYNC2K input

Bit 6: Sync OC-N Rates (OCN). See Section 7.9.3.

0 = SYNC2K is sampled with a 6.48 MHz resolution; the selected reference must be 6.48 MHz

1 = If the selected reference is 19.44 MHz, SYNC2K is sampled at 19.44 MHz and output alignment is to 19.44 MHz. If the selected reference is 38.88 MHz, SYNC2K is sampled at 38.88 MHz. The selected reference must be either 19.44 MHz or 38.88 MHz

Bits 1 to 0: External Sync Sampling Phase. (PHASE[1:0]). This field adjusts the sampling of the SYNC2K input. Normally the falling edge of SYNC2K is aligned with the falling edge of the selected reference. All UI numbers listed below are UI of the sampling clock. See Section 7.9.3.

00 = Coincident

01 = 0.5 UI early

10 = 1 UI late

11 = 0.5 UI late

Register Name: FSCR3
Register Description: Frame Sync Configuration Register 3
Register Address: 7Ch

	Bit 7	Bit 6	Bit 5	Bit 4	Bit 3	Bit 2	Bit 1	Bit 0
Name	RECAL	MONLIM[2:0]			SOURCE[3:0]			
Default	0	0	1	0	1	0	1	1

Bit 7: Phase Offset Recalibration (RECAL). When set to 1 this configuration bit causes a recalibration of the phase offset between the output clocks and the selected reference. This process puts the DPLL into mini holdover, internally ramps the phase offset to zero, resets all clock dividers, ramps the phase offset to the value stored in the [OFFSET](#) registers, and then switches the DPLL out of mini holdover. Unlike simply writing the [OFFSET](#) registers, the RECAL process causes no change in the phase offset of the output clocks. RECAL is automatically reset to 0 when recalibration is complete. See Section [7.7.8](#).

0 = Normal operation

1 = Phase offset recalibration

Bits 6 to 4: Sync Monitor Limit (MONLIM[2:0]). This field configures the sync monitor limit. When the external SYNC2K input is misaligned with respect to the OC11 output by the specified number of resampling clock cycles then a frame sync monitor alarm is declared in the FSMON bit of the [OPSTATE](#) register. See Section [7.9.3](#).

000 = ± 1 UI

001 = ± 2 UI

010 = ± 3 UI

011 = ± 4 UI

100 = ± 5 UI

101 = ± 6 UI

110 = ± 7 UI

111 = ± 8 UI

Bits 3 to 0: Sync Reference Source (SOURCE[3:0]). The external sync reference may be associated with one of the input clocks. When automatic external frame sync is enabled (AEFSEN=1 in the [MCR3](#) register, the SYNC2K pin is only enabled when the T0 DPLL is locked to the input clock specified by the SOURCE field. See Section [7.9.3](#).

0000 = {unused value}

0001 = IC1

0010 = IC2

0011 = IC3

0100 = IC4

0101 = IC5

0110 = IC6

0111 = IC7

1000 = IC8

1001 = IC9

1010 = IC10

1011 = IC11

1100 = IC12

1101 = IC13

1110 = IC14

1111 = {unused value}

Register Name: INTCR
Register Description: Interrupt Configuration Register
Register Address: 7Dh

	Bit 7	Bit 6	Bit 5	Bit 4	Bit 3	Bit 2	Bit 1	Bit 0
Name	—	—	—	—	—	GPO	OD	POL
Default	0	0	0	0	0	0	1	0

Bit 2: INTREQ Pin General-Purpose Output Enable (GPO). When set to 1 this bit configures the interrupt request pin to be a general-purpose output whose value is set by the POL bit.

0 = INTREQ is used for interrupts

1 = INTREQ is a general-purpose output

Bit 1: INTREQ Pin Open-Drain Enable (OD).

When GPO = 0:

0 = INTREQ is driven in both inactive and active states

1 = INTREQ is open-drain, i.e., it is driven in the active state but is high impedance in the inactive state

When GPO = 1:

0 = INTREQ is driven as specified by POL

1 = INTREQ is high impedance and POL has no effect

Bit 0: INTREQ Pin Polarity (POL).

When GPO = 0:

0 = INTREQ goes low to signal an interrupt (active low)

1 = INTREQ goes high to signal an interrupt (active high)

When GPO = 1:

0 = INTREQ driven low

1 = INTREQ driven high

Register Name: PROT
Register Description: Protection Register
Register Address: 7Eh

	Bit 7	Bit 6	Bit 5	Bit 4	Bit 3	Bit 2	Bit 1	Bit 0
Name	PROT[7:0]							
Default	1	0	0	0	0	1	0	1

Bits 7 to 0: Protection Control (PROT[7:0]). This field can be used to protect the rest of the register set from inadvertent writes. In protected mode writes to all other registers are ignored. In single unprotected mode, one register (other than PROT) can be written, but after that write the device reverts to protected mode (and the value of PROT is internally changed to 00h). In fully unprotected mode all register can be written without limitation. See Section 7.2.

1000 0101 = Fully unprotected mode

1000 0110 = Single unprotected mode

all other values = Protected mode

Register Name: IFCR
Register Description: Microprocessor Interface Configuration Register
Register Address: 7Fh

	Bit 7	Bit 6	Bit 5	Bit 4	Bit 3	Bit 2	Bit 1	Bit 0
Name	—	—	—	—	—	IFSEL[2:0]		
Default	0	0	0	0	0	reset value of IFSEL[2:0] pins		

Bits 2:0 Microprocessor Interface Selection (IFSEL[2:0]). This read-only field specifies the microprocessor interface mode. The value of this register is latched from the IFSEL[2:0] pins during reset. After reset the state of the IFSEL[2:0] pins has no effect on this register but is shown in the [IFSR](#) register. See Section [7.12](#).

- 010 = Intel bus mode (multiplexed)
- 011 = Intel bus mode (nonmultiplexed)
- 100 = Motorola mode (nonmultiplexed)
- 101 = SPI mode (address and data transmitted LSB first)
- 110 = Motorola mode (multiplexed)
- 111 = SPI mode (address and data transmitted MSB first)
- 000, 001 = {unused value}

8.5 BITS Transceiver Register Definitions

The DS3100 has two identical, independent BITS transceivers, BITS1 and BITS2. The registers for BITS1 start at 80h while those for BITS2 start at 100h. The register map shown in [Table 8-3](#) applies to both transceivers. The address offsets in the table are added to the base addresses ([Table 8-1](#)) for the BITS transceivers to form a full address. For example, the [BLSR1](#) register in the BITS1 transceiver is located at address 080h + 1Ah = 9Ah.

Table 8-3. BITS Transceiver Register Map

Note: Register names are hyperlinks to register definitions. Underlined fields are read-only.

ADDR OFFSET	REGISTER	BIT 7	BIT 6	BIT 5	BIT 4	BIT 3	BIT 2	BIT 1	BIT 0
04	BMCR	—	—	TMODE[1:0]		—	—	RMODE[1:0]	
08	BCCR1	TCLKS[3:0]			TSYNCS[3:0]				
09	BCCR2	RCLKD[3:0]			RSYNCD[3:0]				
0A	BCCR3	MCLKS	MCLKFC	ROUTS	ROINV	RCINV	ROEN	RCEN	RSEN
0B	BCCR4	TMFS	—	TOUTS	TOINV	TCINV	TOEN	TCEN	TIINV
0C	BCCR5	MPS[1:0]		ZEROS[1:0]		BPV	AIS	LOS	OOF
10	BLCR1	LIRST	—	—	—	—	—	—	LCS
11	BLCR2	—	TION	TIMP[1:0]		0	LBO[2:0]		
12	BLCR3	0	RION	RIMP[1:0]		RTR	RMONEN	RSMS[1:0]	
13	BLCR4	TAIS	—	LLB	ALB	RLB	TPD	RPD	TE
18	BLIR1	—	RFAIL	OEQ	UEQ	—	OC	SC	LOS
19	BLIR2	RL[3:0]			—	—	—	—	—
1A	BLSR1	—	OCC	SCC	LOSC	—	OC	SC	LOS
1B	BLIER1	—	OCC	SCC	LOSC	—	OC	SC	LOS
20	BRMMR	REN	RID	—	—	—	—	RRST	RT1E1
21	BTMMR	TEN	TID	—	—	—	—	TRST	TT1E1
22	BRCR1	SYNCT	RB8ZS	RFM	ARC	SYNCC	RJC	SYNCD	RESYNC
23	BRCR2	—	—	—	—	OOF[1:0]		RAIE	RSFRAI
24	BRCR3	—	RHDB3	RSIGM	—	RCRC4	FRC	SYNCD	RESYNC
25	BRCR4	—	—	—	—	—	—	—	RLOSC
26	BRCR5	—	—	—	—	—	—	RMFS	1
27	BTCCR1	TJC	TFPT	TCPT	—	—	TB8ZS	TAIS	TRAI
28	BTCCR2	—	—	—	FBCT2	FBCT1	TSFRAI	TPDE	TB7ZS
29	BTCCR3	—	—	—	—	—	TFM	IBPV	—
2A	BTCCR4	TFPT	—	—	TSIS	—	THDB3	TAIS	TCRC4
30	BRIIR	—	<u>BRSR4</u>	—	—	—	—	<u>BRSR3</u>	<u>BRSR1</u>
31	BRIR1	—	—	—	—	RAI	AIS	LOS	OOF
32	BRIR2	CSC[5:2:0]			—	—	CRC4SA	CASSA	FASSA
33	BRSR1	RAIC	AISC	LOSC	OOF	RAI	AIS	LOS	OOF
34	BRIER1	RAIC	AISC	LOSC	OOF	RAI	AIS	LOS	OOF
35	BRSR2	RPDV	—	COFA	8ZD	16ZD	SEFE	B8ZS	FBE
36	BRSR3	—	CRCRC	CASRC	FASRC	RSA1	RSA0	RCMF	RAF
37	BRIER3	—	—	—	—	RSA1	RSA0	RCMF	RAF
38	BRSR4	—	—	—	—	—	—	BC	BD
39	BRIER4	—	—	—	—	—	—	BC	BD
3A	BTSR1	—	—	—	—	TPDV/TAF	TMF	LOTCC	LOT
3B	BTIER1	—	—	—	—	TPDV/TAF	TMF	LOTCC	LOT
40	BRBCR	RBR	—	RBD[1:0]		RBF[2:0]			—
41	BTBCR	—	SBOC	—	—	—	—	—	—
42	BRBOC	—	—	RBOC[5:0]					
43	BTBOC	—	—	TBOC[5:0]					
50	BRAAF	Si	FAS[6:0]						
51	BRNAF	Si	1	RAI	Sa4	Sa5	Sa6	Sa7	Sa8
52	BRSiAF	SiF0	SiF2	SiF4	SiF6	SiF8	SiF10	SiF12	SiF14
53	BRSiNAF	SiF1	SiF3	SiF5	SiF7	SiF9	SiF11	SiF13	SiF15

ADDR OFFSET	REGISTER	BIT 7	BIT 6	BIT 5	BIT 4	BIT 3	BIT 2	BIT 1	BIT 0
54	BRRAI	RAIF1	RAIF3	RAIF5	RAIF7	RAIF9	RAIF11	RAIF13	RAIF15
55	BRSa4	Sa4F1	Sa4F3	Sa4F5	Sa4F7	Sa4F9	Sa4F11	Sa4F13	Sa4F15
56	BRSa5	Sa5F1	Sa5F3	Sa5F5	Sa5F7	Sa5F9	Sa5F11	Sa5F13	Sa5F15
57	BRSa6	Sa6F1	Sa6F3	Sa6F5	Sa6F7	Sa6F9	Sa6F11	Sa6F13	Sa6F15
58	BRSa7	Sa7F1	Sa7F3	Sa7F5	Sa7F7	Sa7F9	Sa7F11	Sa7F13	Sa7F15
59	BRSa8	Sa8F1	Sa8F3	Sa8F5	Sa8F7	Sa8F9	Sa8F11	Sa8F13	Sa8F15
5A	BRMCR	—	SSMCH[2:0]			—	—	SSMF[1:0]	
5B	BRMSR	—	—	Sa8	—	Sa7	Sa6	Sa5	Sa4
5C	BRMIER	—	—	Sa8	—	Sa7	Sa6	Sa5	Sa4
5D	BRSSM	—	SSMCH[2:0]			SSM[3:0]			
60	BTAf	Si	FAS[6:0]						
61	BTNAF	Si	1	RAI	Sa4	Sa5	Sa6	Sa7	Sa8
62	BTSiAF	SiF0	SiF2	SiF4	SiF6	SiF8	SiF10	SiF12	SiF14
63	BTSiNAF	SiF1	SiF3	SiF5	SiF7	SiF9	SiF11	SiF13	SiF15
64	BTRAI	RAIF1	RAIF3	RAIF5	RAIF7	RAIF9	RAIF11	RAIF13	RAIF15
65	BTSa4	Sa4F1	Sa4F3	Sa4F5	Sa4F7	Sa4F9	Sa4F11	Sa4F13	Sa4F15
66	BTSa5	Sa5F1	Sa5F3	Sa5F5	Sa5F7	Sa5F9	Sa5F11	Sa5F13	Sa5F15
67	BTSa6	Sa6F1	Sa6F3	Sa6F5	Sa6F7	Sa6F9	Sa6F11	Sa6F13	Sa6F15
68	BTSa7	Sa7F1	Sa7F3	Sa7F5	Sa7F7	Sa7F9	Sa7F11	Sa7F13	Sa7F15
69	BTSa8	Sa8F1	Sa8F3	Sa8F5	Sa8F7	Sa8F9	Sa8F11	Sa8F13	Sa8F15
6A	BTOCR	SiAF	SiNAF	RAI	Sa4	Sa5	Sa6	Sa7	Sa8

BITS Transceiver Register Map Color Coding

	BITS Global Registers
	BITS LIU Registers
	BITS DS1/E1 Framer Registers
	BITS DS1 BOC Controller
	BITS E1 Si/Sa Registers

Register Name: BMCR
Register Description: BITS Mode Configuration Register
Register Address: 04h

	Bit 7	Bit 6	Bit 5	Bit 4	Bit 3	Bit 2	Bit 1	Bit 0
Name	—	—	TMODE[1:0]		—	—	RMODE[1:0]	
Default	0	0	0	0	0	0	0	0

Bits 5 to 4: Transmitter Mode Configuration (TMODE[1:0]). This field configures the operating mode of the BITS transmitter. Note that in DS1 and E1 modes the transmit formatter must also be enabled and configured for DS1 or E1. See Sections 7.10.5.2 (DS1) and 7.10.6.2 (E1) for step-by-step configuration instructions. Table 10-2 indicates the reduction in supply current when the transmitter is powered down. See Section 7.10.7.2 for write sequences that must be done when entering or leaving the 2048 kHz mode.

00 = DS1
 01 = E1
 10 = 2048 kHz¹
 11 = {unused value}

Bits 1 to 0: Receiver Mode Configuration (RMODE[1:0]). This field configures the operating mode of the BITS receiver. Note that in DS1 and E1 modes the receive framer must also be enabled and configured for DS1 or E1. See Sections 7.10.5.1 (DS1) and 7.10.6.1 (E1) for step-by-step configuration instructions. Table 10-2 indicates the reduction in supply current when the receiver is powered down. Values not listed are undefined.

00 = DS1
 01 = E1
 10 = 2048 kHz¹
 11 = 6312 kHz²

Notes

1. Complies with G.703 Section 13.
2. Complies with G.703 appendix II.2 Japanese synchronization interface.
3. TMODE and RMODE can be set to different frequencies.

Register Name: BCCR1
Register Description: BITS Clock Configuration Register 1
Register Address: 08h

	Bit 7	Bit 6	Bit 5	Bit 4	Bit 3	Bit 2	Bit 1	Bit 0
Name	TCLKS[3:0]				TSYNCS[3:0]			
Default	1	0	0	1	1	1	1	1

Bits 7 to 4: Transmit CLK Source (TCLKS[3:0]). See Figure 7-7 and Figure 7-9. This field specifies the source for the 1544 kHz or 2048 kHz clock for the Tx Clock Mux block. When one of the OCx output clocks is specified, that output clock must be configured (see Section 7.8) to have a frequency of 1544 kHz (DS1 mode) or 2048 kHz (E1 mode). See Section 7.10.3.

0000 = TIN input pin
 0001 = Output clock OC1
 0010 = Output clock OC2
 0011 = Output clock OC3
 0100 = Output clock OC4
 0101 = Output clock OC5
 0110 = Output clock OC6
 0111 = Output clock OC7
 1001 = Output clock OC9
 1000, 1010 – 1101 = {unused values}
 1110 = RCLK from the BITS receiver
 1111 = BITS master clock from the BITS master clock PLL

Bits 3 to 0: Transmit SYNC Source (TSYNCS[3:0]). See Figure 7-7 and Figure 7-9. In DS1 and E1 BITS transmitter modes, this field specifies the source of the alignment signal for the 8 kHz frame sync signal (TSYNC). In other BITS transmitter modes this field has no effect. When one of the OCx output clocks is specified, that output clock must be configured (see Section 7.8) to have a frequency of 8 kHz or an integer divider of 8 kHz and it must be frequency locked to the TCLK source specified by TCLKS[3:0]. See Section 7.10.3.

0000 = TIN input pin
 0001 = Output clock OC1
 0010 = Output clock OC2
 0011 = Output clock OC3
 0100 = Output clock OC4
 0101 = Output clock OC5
 0110 = Output clock OC6
 0111 = Output clock OC7
 1010 = Output clock OC10
 1000, 1001, 1011 – 1110 = {unused values}
 1111 = TCLK signal divided by 193 (DS1 mode) or 256 (E1 mode)

Register Name: BCCR2
Register Description: BITS Clock Configuration Register 2
Register Address: 09h

	Bit 7	Bit 6	Bit 5	Bit 4	Bit 3	Bit 2	Bit 1	Bit 0
Name	RCLKD[3:0]				RSYNCD[3:0]			
Default	0	0	0	0	0	0	0	0

Bits 7 to 4: RCLK Destination (RCLKD[3:0]). This field specifies the destination for the BITS receiver's recovered clock, RCLK. For values other than 0000, the RCLKD setting must be coordinated with the configuration of the selected input clock (Section 7.4) and the BITS receiver mode (BMCR:RMODE). The RCLK signal can also be output on the RCLK pin when RCEN=1 in BCCR3. See Section 7.10.2.

0000 = No internal destination
 0001 = Input clock IC1
 0010 = Input clock IC2
 0011 = Input clock IC3
 0100 = Input clock IC4
 0101 = Input clock IC5
 0110 = Input clock IC6
 0111 = Input clock IC7
 1000 = Input clock IC8
 1001 = Input clock IC9
 1010 = Input clock IC10
 1011 = Input clock IC11
 1100 = Input clock IC12
 1101 = Input clock IC13
 1110 = Input clock IC14
 1111 = No internal destination

Bits 3 to 0: RSYNC Destination (RSYNCD[3:0]). This field specifies the destination of the RSYNC signal (Figure 7-7). In DS1 and E1 modes, RSYNC is the recovered 8 kHz frame sync. In other BITS receiver modes RSYNC is inactive and this field has no effect. The RSYNCD setting must be coordinated with the configuration of the selected input clock (Section 7.4) and the BITS receiver mode (BMCR:RMODE). See Section 7.10.2.

0000 = No internal destination
 0001 = Input clock IC1
 0010 = Input clock IC2
 0011 = Input clock IC3
 0100 = Input clock IC4
 0101 = Input clock IC5
 0110 = Input clock IC6
 0111 = Input clock IC7
 1000 = Input clock IC8
 1001 = Input clock IC9
 1010 = Input clock IC10
 1011 = Input clock IC11
 1100 = Input clock IC12
 1101 = Input clock IC13
 1110 = Input clock IC14
 1111 = No internal destination

Register Name: BCCR3
Register Description: BITS Clock Configuration Register 3
Register Address: 0Ah

	Bit 7	Bit 6	Bit 5	Bit 4	Bit 3	Bit 2	Bit 1	Bit 0
Name	MCLKS	MCLKFC	ROUTS	ROINV	RCINV	ROEN	RCEN	RSEN
Default	0	0	0	0	0	0	0	0

Bit 7: MCLK Source (MCLKS). This bit specifies the source for the master clock for both BITS transceivers. When MCLKS=0, **BCCR5:MPS[1:0]** must be set to 00. See Section 7.10.1.

- 0 = Source from 204.8 MHz master clock (divided by 100)
- 1 = Source from MCLK pin

Bit 6: MCLK Frequency Converter (MCLKFC). This bit specifies whether or not to use the 2.048 kHz to 1.544 kHz frequency conversion PLL in the BITS master clock PLL block. See Figure 7-8 and Section 7.10.1.

- 0 = bypass the frequency converter PLL
- 1 = use the output of the frequency converter PLL

Bit 5: ROUT Source (ROUTS). This field specifies the signal source for the ROUT output pin, either RSYNC or RMFSYNC (see Figure 7-7). In DS1 and E1 modes, the RSYNC signal is the received 8 kHz frame sync, and the RMFSYNC signal is the receive multiframe sync, with E1 multiframe type specified by **BRCR5:RMFS**. In 2048 kHz and 6312 kHz modes, RSYNC is held low. See Section 7.10.2.

- 0 = RSYNC signal
- 1 = RMFSYNC signal

Bit 4: ROUT Invert (ROINV). When ROEN=1, this bit specifies the polarity of ROUT. When ROEN=0, the ROUT pin can function as a general-purpose output controlled by this bit. See Section 7.10.2.

ROEN=1

- 0 = Normal: ROUT normally low, pulses high
- 1 = Inverted ROUT normally high, pulses low

ROEN=0

- 0 = ROUT pin forced low
- 1 = ROUT pin forced high

Bit 3: RCLK Invert (RCINV). When RCEN=1, this bit specifies the RCLK edge on which data is updated on the RSER pin (DS1 and E1 modes only). When RCEN=0, the RCLK pin can function as a general-purpose output pin whose value is specified by this bit. See Sections 7.10.5.1 and 7.10.6.1.

RCEN=1

- 0 = Normal: RSER updated on the rising edge of RCLK
- 1 = Inverted: RSER updated on the falling edge of RCLK

RCEN=0

- 0 = RCLK pin forced low
- 1 = RCLK pin forced high

Bit 2: ROUT Enable (ROEN). This bit enables/disables the ROUT output pin. When enabled, ROUT presents the signal specified by **BCCR3:ROUTS**. When disabled, ROUT can function as a general-purpose output controlled by the ROINV configuration bit. See Section 7.10.2.

- 0 = Disabled
- 1 = Enabled

Bit 1: RCLK Enable (RCEN). This bit enables/disables the RCLK output pin. When enabled, RCLK presents the recovered clock from the BITS receiver. When disabled, RCLK can function as a general-purpose output controlled by the RCINV configuration bit. See Section 7.10.2.

- 0 = Disabled
- 1 = Enabled

Bit 0: RSER Enable (RSEN). This bit enables/disables the RSER output pin. In DS1 and E1 receiver modes (**BMCR:RMODE=0x**), RSER presents the entire received data stream, both payload and overhead. In all other BITS receiver modes RSER is disabled and this bit has no effect. See Section 7.10.2.

- 0 = Disabled (low)
- 1 = Enabled

Register Name: BCCR4
Register Description: BITS Clock Configuration Register 4
Register Address: 0Bh

	Bit 7	Bit 6	Bit 5	Bit 4	Bit 3	Bit 2	Bit 1	Bit 0
Name	TMFS	—	TOUTS	TOINV	TCINV	TOEN	TCEN	TIINV
Default	0	0	0	0	0	0	0	0

Bit 7: Transmit Multiframe Sync Source (TMFS). In DS1 and E1 modes, this field specifies the source of the transmit multiframe signal (TMFSYNC). In other BITS transmitter modes this field has no effect. When the TIN pin is specified, the signal on TIN must be frequency locked to the TCLK source specified by [BCCR1:TCLKS\[3:0\]](#). See Section [7.10.3](#).

- 0 = TSYNC signal divided by 12 (DS1 SF), 24 (DS1 ESF), or 16 (E1)
- 1 = TIN input pin

Bit 5: TOUT Source (TOUTS). This field specifies the signal source for the TOUT output pin. See [Figure 7-7](#). In DS1 and E1 modes, the TSYNC signal is the transmit 8 kHz frame sync, and the TMFSYNC signal is the transmit multiframe sync. In other BITS transmitter modes this bit has no effect. See Section [7.10.3](#)

- 0 = TSYNC signal
- 1 = TMFSYNC signal

Bit 4: TOUT Invert (TOINV). See Section [7.10.3](#).

- 0 = Normal: TOUT normally low, pulses high
- 1 = Inverted: TOUT normally high, pulses low

Bit 3: TCLK Invert (TCINV). Specifies the TCLK clock edge on which data is sampled from TSER and TIN. This bit only has an effect in DS1 and E1 BITS transmitter modes ([BMCR:TMODE=0x](#)). See Sections [7.10.5.2](#) and [7.10.6.2](#).

- 0 = Normal: TSER and TIN updated on the falling edge of TCLK
- 1 = Inverted: TSER and TIN updated on the rising edge of TCLK

Bit 2: TOUT Enable (TOEN). This bit enables/disables the TOUT output pin. When enabled, TOUT presents the signal specified by TOUTS. In 2048 kHz mode this bit has no effect, and TOUT remains low. See Section [7.10.3](#).

- 0 = Disabled (low)
- 1 = Enabled

Bit 1: TCLK Enable (TCEN). This bit enables/disables the TCLK output pin. See Section [7.10.3](#).

- 0 = Disabled (low)
- 1 = Enabled

Bit 0: TIN Invert (TIINV). When high See Section [7.10.3](#).

- 0 = Normal: TIN normally low, pulses high
- 1 = Inverted: TIN normally high, pulses low

Register Name: BCCR5
Register Description: BITS Clock Configuration Register 5
Register Address: 0Ch

	Bit 7	Bit 6	Bit 5	Bit 4	Bit 3	Bit 2	Bit 1	Bit 0
Name	MPS[1:0]		ZEROS[1:0]		BPV	AIS	LOS	OOF
Default	0	0	0	0	0	0	0	0

Bits 7 to 6: MCLK Prescaler (MPS[1:0]). This field configures the divider in the MCLK prescaler block. When **BCCR3:MCLKS=0**, MPS[1:0] must be set to 00. See [Figure 7-8](#) and [Section 7.10.1](#).

- 00 = Divide by 1 (pass through MCLK signal unchanged)
- 01 = Divide by 2
- 10 = Divide by 4
- 11 = Divide by 8

Bits 5 to 4: Squelch and Increment on Zeros (ZEROS[1:0]). If this field is set to a non-zero value in any mode and the specified number of consecutive zeros are detected (prior to B8ZS/HDB3 decoding), then the BITS receiver automatically squelches its output clock. The resulting lack of clock edges increments the activity monitor for the input clock connected to the BITS receiver (as specified in **BCCR2:RCLKD**). See [Sections 7.5](#) and [7.10.2](#). When ultra-fast switching is enabled (**MCR10:UFSW = 1**), squelching the clock causes that input clock to be immediately invalidated. See [section 7.6.4](#).

- 00 = Do not invalidate on zeros
- 01 = Invalidate on a string of 4 consecutive zeros
- 10 = Invalidate on a string of 8 consecutive zeros
- 11 = Invalidate on a string of 16 consecutive zeros

Bit 3: Increment the Activity Monitor on BPVs (BPV). If this bit is set to 1 in DS1 or E1 receiver modes then the detection of an unexpected BPV is considered an irregularity by the activity monitors for the ICx input clocks to which RCLK and RSYNC are connected (as specified in **BCCR2:RCLKD** and **RSYNCD**). The activity monitors increment their leaky bucket accumulators once for each 128-ms interval in which irregularities occur. An unexpected BPV is one that is not part of a valid B8ZS or HDB3 codeword. If this bit is set to 1 in 2048 kHz mode then the detection of an unexpected BPV or zero is considered an irregularity by the relevant activity monitors. In 6312 kHz receiver mode this bit has no effect. See [Sections 7.5](#) and [7.10.2](#).

- 0 = BPVs do not increment the input clock activity monitors
- 1 = BPVs do increment the input clock activity monitors

Bit 2: Invalidate on Alarm Indication Signal (AIS). If this bit is set to 1 in DS1 and E1 receiver modes and AIS (i.e. unframed all ones) is detected in the receive data stream, then the device automatically invalidates the ICx input clocks to which RCLK and RSYNC are connected (as specified in **BCCR2:RCLKD** and **RSYNCD**). Invalidation means the corresponding bit in the **VALSR** registers is set to 0. See [Table 7-16](#) (DS1) and [Table 7-17](#) (E1) for AIS set and clear criteria. In other receiver modes this bit has no effect. See [Sections 7.5](#) and [7.10.2](#).

- 0 = Do not invalidate on AIS
- 1 = Invalidate on AIS

Bit 1: Invalidate on Loss of Signal (LOS). If this bit is set to 1 in any receiver mode and the receiver declares loss of signal (**BLIR1:LOS = 1**), then the device automatically invalidates the ICx input clocks to which RCLK and RSYNC are connected (as specified in **BCCR2:RCLKD** and **RSYNCD**). Invalidation means the corresponding bit in the **VALSR** registers is set to 0. Regardless of the setting of this bit, RCLK and RSYNC are squelched when the receiver declares LOS. See [Sections 7.5](#) and [7.10.2](#).

- 0 = Do not invalidate on LOS
- 1 = Invalidate on LOS

Bit 0: Invalidate on Out of Frame (OOF). If this bit is set to 1 in DS1 and E1 receiver modes and the receive framer declares out-of-frame (**BRIR1:OOF=1**), then the device automatically invalidates the ICx input clocks to which RCLK and RSYNC are connected (as specified in **BCCR2:RCLKD** and **RSYNCD**). Invalidation means the corresponding bit in the **VALSR** registers is set to 0. In other receiver modes this bit has no effect. See [Sections 7.5](#) and [7.10.2](#).

- 0 = Do not invalidate on OOF
- 1 = Invalidate on OOF

Register Name: BLCR1
Register Description: BITS LIU Configuration Register 1
Register Address: 10h

	Bit 7	Bit 6	Bit 5	Bit 4	Bit 3	Bit 2	Bit 1	Bit 0
Name	LIRST	—	—	—	—	—	—	LCS
Default	0	0	0	0	0	0	0	1

Bit 7: Line Interface Reset (LIRST). A zero-to-one transition resets the clock recovery state machine. Normally this bit is only toggled after power-up. LIRST must be cleared and set again for a subsequent reset.

Bit 0: LOS Criteria Selection (LCS). In E1 mode this bit specifies the loss of signal criteria to use. In DS1 mode, LOS criteria is always based on ANSTI T1.231, and this bit has no effect. See Section 7.10.4.1.

0 = G.775 criteria (192-bit window)

1 = ETSI 300 233 criteria (2048-bit window)

Register Name: BLCR2
Register Description: BITS LIU Configuration Register 2
Register Address: 11h

	Bit 7	Bit 6	Bit 5	Bit 4	Bit 3	Bit 2	Bit 1	Bit 0
Name	—	TION	TIMP[1:0]		0	LBO[2:0]		
Default	0	0	0	0	0	0	0	0

Bit 6: Transmitter Impedance On (TION). See Section 7.10.4.2.

0 = Disable internal transmitter termination

1 = Enable internal transmitter termination with impedance set by TIMP[1:0]

Bits 5 to 4: Transmit Impedance (TIMP[1:0]). This field specifies the transmit cable impedance. The actual transmit cable impedance must be specified by this field for proper operation, regardless of the value of the TION bit. For J1 applications, use 110Ω. See Section 7.10.4.1.6.

00 = 75Ω

01 = 100Ω

10 = 110Ω

11 = 120Ω

Bit 3: Leave set to zero (test control).

Bits 2 to 0: Transmitter Line Build-Out (LBO[2:0]). This field specifies the line build-out setting for the BITS transmitter. Values not listed are undefined. This field is ignored in BITS modes other than DS1 and E1. See Section 7.10.4.1.6.

DS1 Mode

000 = DSX-1 (0 to 133 feet) / 0 dB CSU

001 = DSX-1 (133 to 266 feet)

010 = DSX-1 (266 to 399 feet)

011 = DSX-1 (399 to 533 feet)

100 = DSX-1 (533 to 655 feet)

101 = -7.5 dB CSU

110 = -15 dB CSU

111 = -22.5 dB CSU

E1 Mode

000 = 75Ω, nominal voltage = 2.37V

001 = 120Ω, nominal voltage = 3.0V

Register Name: BLCR3
Register Description: BITS LIU Configuration Register 3
Register Address: 12h

	Bit 7	Bit 6	Bit 5	Bit 4	Bit 3	Bit 2	Bit 1	Bit 0
Name	0	RION	RIMP[1:0]		RTR	RMONEN	RSMS[1:0]	
Default	0	0	0	0	0	0	0	0

Bit 7: Leave set to zero (test control).

Bit 6: Receiver Impedance On (RION). See Section 7.10.4.1.

0 = Disable internal receiver termination, RTIP/RRING are high-impedance

1 = Enable internal receiver termination with impedance set by RIMP[1:0]

Bits 5 to 4: Receive Impedance (RIMP[1:0]). This field specifies the receive cable impedance. When internal termination impedance is enabled (RION=1), the internal impedance is set to the value specified by this field. When internal termination impedance is disabled (RION=0), the actual receive cable impedance must be specified by this field for proper operation. See Section 7.10.4.1.

00 = 75Ω

01 = 100Ω

10 = 110Ω

11 = 120Ω

Bit 3: Receiver Turns Ratio (RTR). See Section 7.10.4.1.

0 = Receiver transformer turns ratio is 1:1

1 = Receiver transformer turns ratio is 2:1. This option should only be used in short haul applications.

Bit 2 : Receiver Monitor Mode Enable (RMONEN). In DS1, E1 and 2048 kHz modes this field enables and disables monitor mode. In 6312 kHz mode, this field has no effect. See Section 7.10.4.1.

0 = Disable receive monitor mode

1 = Enable receiver monitor mode. Flat gain is added with the maximum sensitivity. The receiver sensitivity is determined by RSMS[1:0].

Bits 1 to 0: Receiver Sensitivity / Monitor Select (RSMS[1:0]). In DS1, E1 and 2048 kHz modes, this field controls the receiver sensitivity level and additional gain in monitoring applications. The monitor mode (RMONEN=1) adds flat gain to compensate for the signal loss caused by isolation resistors. In 6312 kHz mode this field has no effect. See Section 7.10.4.1.

RMONEN	RSMS [1:0]	RECEIVER MONITOR MODE GAIN (dB)	DS1/E1 RECEIVER SENSITIVITY (MAX CABLE LOSS ALLOWED) (dB)
0	00	0	12
0	01	0	18
0	10	0	30
0	11	0	36 (DS1), 43 (E1)
1	00	14	30
1	01	20	22.5
1	10	26	17.5
1	11	32	12

In 2048kHz mode, the receiver sensitivity numbers are approximately 8dB lower than the E1 values shown in the table.

Register Name: BLCR4
Register Description: BITS LIU Configuration Register 4
Register Address: 13h

	Bit 7	Bit 6	Bit 5	Bit 4	Bit 3	Bit 2	Bit 1	Bit 0
Name	TAIS	—	LLB	ALB	RLB	TPD	RPD	TE
Default	0	0	0	0	0	1	1	0

Bit 7: Transmit AIS (TAIS). This field is ignored in BITS modes other than DS1 and E1. See Section 7.10.4.1.6.

0 = Transmit data normally

1 = Transmit AIS (unframed all-ones) on TTIP and TRING

Bit 5: Local Loopback (LLB). Local loopback loops the output of the transmit formatter back to the input of the receive framer. During this loopback transmit data propagates through the transmit side of the BITS transceiver as it normally would, but the recovered clock and data from the LIU receiver is ignored. See Figure 7-7 for the exact loopback path.

0 = Disabled

1 = Enabled

Bit 4: Analog Loopback (ALB). Analog loopback loops the output of the LIU transmitter back to the input of the LIU receiver. During this loopback transmit data propagates through the transmit side of the BITS transceiver as it normally would, but the incoming signal on RTIP/RRING is ignored. See Figure 7-7 for the exact loopback path.

0 = Disabled

1 = Enabled

Bit 3: Remote Loopback (RLB). Remote loopback loops the output of the LIU receiver back to the input of the LIU transmitter. During this loopback received data propagates through the receive side of the BITS transceiver as it normally would, but the output from the transmit formatter is ignored. See Figure 7-7 for the exact loopback path. (Note: A remote loopback of the recovered clock can also be accomplished by setting `BCCR1:TCLKS[3:0] = 1110` to connect RCLK to TCLK. See Figure 7-7 and Figure 7-9.)

0 = Disabled

1 = Enabled

Bit 2: Transmitter Power Down (TPD). Table 10-2 indicates the reduction in supply current when the transmitter is powered down. Note that the transmitter takes approximately 50ms to stabilize after TPD is set to 0. See Section 7.10.4.2.

0 = Normal transmitter operation

1 = Power down the transmitter and put TTIP and TRING pins in a high-impedance state (default)

Bit 1: Receiver Power Down (RPD). Table 10-2 indicates the reduction in supply current when the receiver is powered down. Note that the receiver takes approximately 50ms to stabilize after RPD is set to 0. See Section 7.10.4.1.

0 = Normal receiver operation

1 = Power down the receiver (default)

Bit 0: Transmit Enable (TE). See Section 7.10.4.2.3.

0 = Transmitter output driver disabled; TTIP and TRING pins in a high-impedance state

1 = Transmitter output driver enabled; TTIP and TRING active (THZE1 or THZE2 pin must be low)

Register Name: BLIR1
Register Description: BITS LIU Information Register 1
Register Address: 18h

	Bit 7	Bit 6	Bit 5	Bit 4	Bit 3	Bit 2	Bit 1	Bit 0
Name	—	<u>RFAIL</u>	<u>OEQ</u>	<u>UEQ</u>	—	<u>OC</u>	<u>SC</u>	<u>LOS</u>
Default	0	0	0	0	0	0	0	0

Bit 6: Receiver Failure (RFAIL). This real-time status bit is set to 1 when the a short-circuit (less than 25Ω) is detected on RTIP and/or RRING.

0 = Normal operation

1 = Short-circuit detected on RTIP and/or RRING

Bit 5: Receive Over-Equalized (OEQ). This real-time status bit is set to 1 when the equalizer in the LIU receiver is over-equalized. This can happen if there is a very large unexpected resistive loss, such as when the device is placed in a monitor mode application without being configured for monitor mode ([BLCR3:RMONEN](#)). This indicator provides additional information when the receiver is indicating loss-of-signal in the LOS status bit. See Section [7.10.4.1](#).

Bit 4: Receive Under-Equalized (UEQ). This real-time status bit is set to 1 when the equalizer in the LIU receiver is under-equalized. A signal with a very high resistive gain is being applied. This indicator provides additional information when the receiver is indicating loss-of-signal in the LOS status bit. See Section [7.10.4.1](#).

Bit 2: Transmit Open Circuit (OC). This real-time status bit is set to 1 when the LIU detects that the TTIP and TRING outputs are open-circuited. Register [BLSR1](#) has latched status bits that are set when OC changes state, both low-to-high and high-to-low. See Section [7.10.4.1.6](#).

Bit 1: Transmit Short Circuit (SC). This real-time status bit is set to 1 when the LIU detects that the TTIP and TRING outputs are short-circuited. The short circuit resistance has to be 25Ω (typically) or less for short circuit detection. Register [BLSR1](#) has latched status bits that are set when SC changes state, both low-to-high and high-to-low. See Section [7.10.4.1.6](#).

Bit 0: Receive Loss of Signal (LOS). This real-time status bit is set to 1 when the LIU receiver detects an LOS condition at RTIP and RRING. Register [BLSR1](#) has latched status bits that are set when LOS changes state, both low-to-high and high-to-low. See Section [7.10.4.1](#).

Register Name: BLIR2
Register Description: BITS LIU Information Register 2
Register Address: 19h

	Bit 7	Bit 6	Bit 5	Bit 4	Bit 3	Bit 2	Bit 1	Bit 0
Name	RL[3:0]				—	—	—	—
Default	0	0	0	0	0	0	0	0

Bits 7 to 4: Receive Level (RL[3:0]). This real-time field indicates the pulse amplitude of the signal coming into the BITS LIU receiver. A value of 0 dB means 3.0V for DS1 and 2.37V for E1 and 2048 kHz. In 6312 kHz mode, a value of 0 means 0 dBm. See Section 7.10.4.1.

RL[3:0]	RECEIVE LEVEL (dB)
0000	> -2.5
0001	-2.5 to -5.0
0010	-5.0 to -7.5
0011	-7.5 to -10.0
0100	-10.0 to -12.5
0101	-12.5 to -15.0
0110	-15.0 to -17.5
0111	-17.5 to -20.0
1000	-20 to -22.5
1001	-22.5 to -25.0
1010	-25.0 to -27.5
1011	-27.5 to -30.0
1100	-30.0 to -32.5
1101	-32.5 to -35.0
1110	-35.0 to -37.5
1111	< -37.5

Register Name: BLSR1
Register Description: BITS LIU Status Register 1
Register Address: 1Ah

	Bit 7	Bit 6	Bit 5	Bit 4	Bit 3	Bit 2	Bit 1	Bit 0
Name	—	OCC	SCC	LOSC	—	OC	SC	LOS
Default	0	0	0	0	0	0	0	0

Bit 6: Transmit Open Circuit Clear (OCC). This latched status bit is set to 1 when BLIR1:OC changes state from high to low. OCC is cleared when written with a 1. When OCC is set it can cause an interrupt request on the INTREQ pin if the OCC interrupt enable bit is set in the BLIER1 register. See Section 7.10.4.1.6.

Bit 5: Transmit Short Circuit Clear (SCC). This latched status bit is set to 1 when BLIR1:SC changes state from high to low. SCC is cleared when written with a 1. When SCC is set it can cause an interrupt request on the INTREQ pin if the SCC interrupt enable bit is set in the BLIER1 register. See Section 7.10.4.1.6.

Bit 4: Receive Loss of Signal Clear (LOSC). This latched status bit is set to 1 when BLIR1:LOS changes state from high to low. LOSC is cleared when written with a 1. When LOSC is set it can cause an interrupt request on the INTREQ pin if the LOSC interrupt enable bit is set in the BLIER1 register. See Section 7.10.4.1.

Bit 2: Transmit Open Circuit Detect (OC). This latched status bit is set to 1 when BLIR1:OC changes state from low to high. OC is cleared when written with a 1. When OC is set it can cause an interrupt request on the INTREQ pin if the OC interrupt enable bit is set in the BLIER1 register. See Section 7.10.4.2.7.

Bit 1: Transmit Short Circuit Detect (SC). This latched status bit is set to 1 when BLIR1:SC changes state from low to high. SC is cleared when written with a 1. When SC is set it can cause an interrupt request on the INTREQ pin if the SC interrupt enable bit is set in the BLIER1 register. See Section 7.10.4.2.6.

Bit 0: Receive Loss of Signal Detect (LOS). This latched status bit is set to 1 when BLIR1:LOS changes state from low to high. LOS is cleared when written with a 1. When LOS is set it can cause an interrupt request on the INTREQ pin if the LOS interrupt enable bit is set in the BLIER1 register. See Section 7.10.4.1.6.

Register Name: BLIER1
Register Description: BITS LIU Interrupt Enable Register 1
Register Address: 1Bh

	Bit 7	Bit 6	Bit 5	Bit 4	Bit 3	Bit 2	Bit 1	Bit 0
Name	—	OCC	SCC	LOSC	—	OC	SC	LOS
Default	0	0	0	0	0	0	0	0

Bit 6: Interrupt Enable for Transmit Open Circuit Clear (OCC). This bit is an interrupt enable for the OCC bit in the [BLSR1](#) register.

0 = Mask the interrupt

1 = Enable the interrupt

Bit 5: Interrupt Enable for Transmit Short Circuit Clear (SCC). This bit is an interrupt enable for the SCC bit in the [BLSR1](#) register.

0 = Mask the interrupt

1 = Enable the interrupt

Bit 4: Interrupt Enable for Receive Loss of Signal Clear (LOSC). This bit is an interrupt enable for the LOSC bit in the [BLSR1](#) register.

0 = Mask the interrupt

1 = Enable the interrupt

Bit 2: Interrupt Enable for Transmit Open Circuit Detect (OC). This bit is an interrupt enable for the OC bit in the [BLSR1](#) register.

0 = Mask the interrupt

1 = Enable the interrupt

Bit 1: Interrupt Enable for Transmit Short Circuit Detect (SC). This bit is an interrupt enable for the SC bit in the [BLSR1](#) register.

0 = Mask the interrupt

1 = Enable the interrupt

Bit 0: Interrupt Enable for Receive Loss of Signal (LOS). This bit is an interrupt enable for the LOS bit in the [BLSR1](#) register.

0 = Mask the interrupt

1 = Enable the interrupt

Register Name: BRMMR
Register Description: BITS Receive Master Mode Register
Register Address: 20h

	Bit 7	Bit 6	Bit 5	Bit 4	Bit 3	Bit 2	Bit 1	Bit 0
Name	REN	RID	—	—	—	—	RRST	RT1E1
Default	0	0	0	0	0	0	0	0

These register fields affect the receive framer only. See Sections 7.10.5.1 and 7.10.6.1.

Bit 7: Receive Framer Enable (REN). This bit must be written with the desired value prior to setting the RID bit.
 0 = Receive framer disabled (held in low-power state)
 1 = Receive framer enabled (all features active)

Bit 6: Receive Initialization Done (RID). System software must set the RT1E1 and REN bits prior to setting this bit. Once RID is set, the receiver is enabled if REN = 1.

Bit 1: Receive Soft Reset (RRST). Level-sensitive reset. Should be set to 1, then to 0 to reset and initialize the receive framer.
 0 = Normal operation
 1 = Hold the receive framer in reset

Bit 0: Receive T1/E1 Mode Select (RT1E1). This bit specifies the operating mode for the receive framer only. The BTMMR:TT1E1 bit specifies the operating mode for the transmit formatter. This bit must be set to the desired value before setting the RID bit.
 0 = T1 (DS1) operation
 1 = E1 operation

Register Name: BTMMR
Register Description: BITS Transmit Master Mode Register
Register Address: 21h

	Bit 7	Bit 6	Bit 5	Bit 4	Bit 3	Bit 2	Bit 1	Bit 0
Name	TEN	TID	—	—	—	—	TRST	TT1E1
Default	0	0	0	0	0	0	0	0

These register fields affect the transmit formatter only. See Sections [7.10.5.2](#) and [7.10.6.2](#).

Bit 7: Transmit Formatter Enable (TEN). This bit must be written with the desired value prior to setting the TID bit.

- 0 = Transmit formatter disabled (held in low-power state)
- 1 = Transmit formatter enabled (all features active)

Bit 6: Transmit Initialization Done (TID). System software must set the TT1E1 and TEN bits prior to setting this bit. Once TID is set, the transmitter is enabled if TEN = 1.

Bit 1: Transmit Soft Reset (TRST). Level-sensitive reset. Should be set to 1, then to 0 to reset and initialize the transmit formatter.

- 0 = Normal operation
- 1 = Hold the transmit formatter in reset

Bit 0: Transmit T1/E1 Mode Select (TT1E1). This bit specifies the operating mode for the transmit formatter only. The [BRMMR:RT1E1](#) bit specifies the operating mode for the receive framer. This bit must be set to the desired value before setting the TID bit.

- 0 = T1 (DS1) operation
- 1 = E1 operation

Register Name: BRCR1
Register Description: BITS Receive Configuration Register 1 (DS1 only)
Register Address: 22h

	Bit 7	Bit 6	Bit 5	Bit 4	Bit 3	Bit 2	Bit 1	Bit 0
Name	SYNCT	RB8ZS	RFM	ARC	SYNCC	RJC	SYNCD	RESYNC
Default	0	0	0	0	0	0	0	0

The fields of this register configure the receive framer when it is in DS1 mode only (BRMMR:RT1E1=0). In E1 mode this register is reserved and should not be written. See Section 7.10.5.1.

Bit 7: Sync Time (SYNCT). This bit specifies the number of framing bits to qualify. The type of framing bits to qualify is specified by the SYNCC configuration bit.

- 0 = Qualify 10 bits
- 1 = Qualify 24 bits

Bit 6: Receive B8ZS Enable (RB8ZS).

- 0 = B8ZS decoding disabled
- 1 = B8ZS decoding enabled

Bit 5: Receive Frame Mode Select (RFM).

- 0 = ESF framing mode
- 1 = SF (D4) framing mode

Bit 4: Auto Resync Criteria (ARC).

- 0 = Resync on OOF or LOS event
- 1 = Resync on OOF only

Bit 3: Sync Criteria (SYNCC).

Superframe (SF) mode

- 0 = Search for Ft pattern then search for Fs pattern
- 1 = Cross-couple Ft and Fs pattern

Extended Superframe (ESF) framing mode

- 0 = Search for FPS pattern only
- 1 = Search for FPS and verify with CRC6

Bit 2: Receive Japanese CRC-6 Enable (RJC).

- 0 = use ANSI/AT&T/ITU CRC-6 calculation (normal DS1 operation)
- 1 = use Japanese standard JT-G704 CRC-6 calculation (for J1 operation)

Bit 1: Sync Disable (SYNCD). The bit specifies whether or not the receive framer automatically attempts to resynchronize to (i.e. search for the start-of-frame in) the incoming signal.

- 0 = Auto resync enabled
- 1 = Auto resync disabled

Bit 0: Resynchronize (RESYNC). A zero-to-one transition causes the receive framer to resynchronize to (i.e. search for the start of frame in) the incoming signal. RESYNC must be cleared and set again for a subsequent resync.

Register Name: BRCR2
Register Description: BITS Receive Configuration Register 2 (DS1 only)
Register Address: 23h

	Bit 7	Bit 6	Bit 5	Bit 4	Bit 3	Bit 2	Bit 1	Bit 0
Name	—	—	—	—	OOFC[1:0]		RAIIE	RSFRAI
Default	0	0	0	0	0	0	0	0

The fields of this register configure the receive framer when it is in DS1 mode only (**BRMMR:RT1E1=0**). In E1 mode this register is reserved and should not be written. See Section 7.10.5.1.

Bits 3 to 2: Out of Frame Criteria (OOFC[1:0]). This field specifies the criteria for declaring an out-of-frame (OOF) defect in **BRIR1:OOF**.

- 00 = 2/4 frame bits in error
- 01 = 2/5 frame bits in error
- 10 = 2/6 frame bits in error
- 11 = 2/6 frame bits in error

Bit 1: Receive RAI Integration Enable (RAIIE). The ESF RAI indication can be interrupted for a period not to exceed 100 ms per interruption (T1.403). In ESF mode, setting RAIIE causes the RAI status to be integrated for 200ms. The RAI defect is indicated in **BRIR1:RAI**.

- 0 = RAI declared when 16 consecutive patterns of 00FFh appear in the FDL.
RAI cleared when 14 or less patterns of 00FFh out of 16 possible appear in the FDL.
- 1 = RAI declared when the condition has been present for greater than 200ms.
RAI cleared when the condition has been absent for greater than 200ms.

Bit 0: Receive Superframe RAI Select (RSFRAI). When the receive framer is in superframe mode this bit specifies the type of RAI signal to detect.

- 0 = Zeros in bit 2 of all channels (normal DS1 operation)
- 1 = A one in the Fs bit position of frame 12 (J1 operation)

Register Name: BRCR3
Register Description: BITS Receive Configuration Register 3 (E1 only)
Register Address: 24h

	Bit 7	Bit 6	Bit 5	Bit 4	Bit 3	Bit 2	Bit 1	Bit 0
Name	—	RHDB3	RSIGM	—	RCRC4	FRC	SYNCD	RESYNC
Default	0	0	0	0	0	0	0	0

The fields of this register configure the receive framer when it is in E1 mode only (BRMMR:RT1E1=1). In DS1 mode this register is reserved and should not be written. See Section 7.10.6.1.

Bit 6: Receive HDB3 Enable (RHDB3).

- 0 = HDB3 decoding disabled
- 1 = HDB3 decoding enabled

Bit 5: Receive Signaling Mode Select (RSIGM).

- 0 = CAS signaling mode
- 1 = CCS signaling mode

Bit 3: Receive CRC-4 Enable (RCRC4).

- 0 = CRC-4 framing disabled
- 1 = CRC-4 framing enabled

Bit 2: Frame Resync Criteria (FRC).

- 0 = Resync if FAS is received in error three consecutive times
- 1 = Resync if either FAS or bit 2 of non-FAS is received in error three consecutive times

Bit 1: Sync Disable (SYNCD). The bit specifies whether or not the receive framer automatically attempts to resynchronize to (i.e. search for the start-of-frame in) the incoming signal.

- 0 = Auto resync enabled
- 1 = Auto resync disabled

Bit 0: Resynchronize (RESYNC). A zero-to-one transition causes the receive framer to resynchronize to (i.e. search for the start of frame in) the incoming signal. RESYNC must be cleared and set again for a subsequent resync.

Register Name: BRCR4
Register Description: BITS Receive Configuration Register 4 (E1 only)
Register Address: 25h

	Bit 7	Bit 6	Bit 5	Bit 4	Bit 3	Bit 2	Bit 1	Bit 0
Name	—	—	—	—	—	—	—	RLOSC
Default	0	0	0	0	0	0	0	0

The fields of this register configure the receive framer when it is in E1 mode only (BRMMR:RT1E1=1). In DS1 mode this register is reserved and should not be written. See Section 7.10.6.1.

Bit 0: Receive Loss of Signal Criteria (RLOSC).

- 0 = RLOS declared upon 255 consecutive zeros (125 μ s)
- 1 = RLOS declared upon 2048 consecutive zeros (1 ms)

Register Name: BRCR5
Register Description: BITS Receive Configuration Register 5 (DS1 and E1)
Register Address: 26h

	Bit 7	Bit 6	Bit 5	Bit 4	Bit 3	Bit 2	Bit 1	Bit 0
Name	—	—	—	—	—	—	RMFS	1
Default	0	0	0	0	0	0	0	1

Bit 1: Receive Multiframe Sync Mode (RMFS). In E1 mode, this bit specifies the type of multiframe sync that comes out of the receive framer on the RMFSYNC node (Figure 7-7). In DS1 mode this bit must be set to 0. See Section 7.10.2.

0 = Pulse on CAS multiframe boundary

1 = Pulse on CRC-4 multiframe boundary

Bit 0: Leave set to one (test control).

Register Name: BTCR1
Register Description: BITS Transmit Configuration Register 1 (DS1 only)
Register Address: 27h

	Bit 7	Bit 6	Bit 5	Bit 4	Bit 3	Bit 2	Bit 1	Bit 0
Name	TJC	TFPT	TCPT	—	—	TB8ZS	TAIS	TRAI
Default	0	0	0	0	0	0	0	0

The fields of this register configure the transmit formatter when it is in DS1 mode only (BTMMR:TT1E1=0). In E1 mode this register is reserved and should not be written. See Section 7.10.5.2.

Bit 7: Transmit Japanese CRC-6 Enable (TJC).

- 0 = Use ANSI/AT&T/ITU CRC-6 calculation (normal DS1 operation)
- 1 = Use Japanese standard JT-G704 CRC-6 calculation (J1 operation)

Bit 6: Transmit F-Bit Pass-Through (TFPT).

- 0 = F bits sourced internally
- 1 = F bits sourced from TSER pin

Bit 5: Transmit CRC Pass-Through (TCPT).

- 0 = CRC-6 bits sourced internally
- 1 = CRC-6 bits sourced from TSER pin during F-bit time

Bit 2: Transmit B8ZS Enable (TB8ZS).

- 0 = B8ZS encoding disabled
- 1 = B8ZS encoding enabled

Bit 1: Transmit Alarm Indication Signal (TAIS).

- 0 = Do not transmit AIS
- 1 = Transmit AIS (unframed all-ones)

Bit 0: Transmit Remote Alarm Indication (TRAI).

- 0 = Do not transmit RAI
- 1 = Transmit RAI

Register Name: BTCR2
Register Description: BITS Transmit Configuration Register 2 (DS1 only)
Register Address: 28h

	Bit 7	Bit 6	Bit 5	Bit 4	Bit 3	Bit 2	Bit 1	Bit 0
Name	—	—	—	FBCT2	FBCT1	TSFRAI	TPDE	TB7ZS
Default	0	0	0	0	0	0	0	0

The fields of this register configure the transmit formatter when it is in DS1 mode only (BTMMR:TT1E1=0). In E1 mode this register is reserved and should not be written. See Section 7.10.5.2.

Bit 4: F-Bit Corruption Type 2 (FBCT2). Setting this bit to 1 enables the corruption of one out of every 128 Ft bits (SF framing mode) or one out of every 128 FPS bits (ESF framing mode). F-bit corruption continues as long as FBCT2=1.

Bit 3: F-Bit Corruption Type 1 (FBCT1). A zero-to-one transition causes the next three consecutive Ft bits (SF framing mode) or FPS bits (ESF framing mode) to be corrupted. This corruption is sufficient to cause the remote end to experience a loss of frame synchronization.

Bit 2: Transmit Superframe RAI Select (TSFRAI). When the transmit formatter is in superframe mode this bit specifies the type of RAI signal to transmit.

- 0 = Zeros in bit 2 of all channels (normal DS1 operation)
- 1 = A one in the Fs bit position of frame 12 (J1 operation)

Bit 1: Pulse Density Enforcer Enable (TPDE). The framer always examines both the transmit and receive data streams for violations of the ANSI T1.403 pulse density rules: no more than 15 consecutive zeros and at least N ones in each and every time window of $8 \times (N + 1)$ bits where $N = 1$ through 23. Violations for the transmit and receive data streams are reported in the BTSR1:TPDV and BRSR2:RPDV bits respectively. When this bit is set to one, the transmit formatter will force the transmitted stream to meet this requirement no matter the content of the transmitted stream. When B8ZS encoding is enabled (BTCCR1:TB8ZS=1), this bit should be set to zero since B8ZS-encoded data streams cannot violate the pulse density requirements.

- 0 = Disable transmit pulse density enforcer
- 1 = Enable transmit pulse density enforcer

Bit 0: Transmit Bit 7 Zero-Suppression Enable (TB7ZS).

- 0 = No stuffing occurs
- 1 = Bit 7 forced to 1 in channels with all zeros

Register Name: BTCR3
Register Description: BITS Transmit Configuration Register 3 (DS1 and E1)
Register Address: 29h

	Bit 7	Bit 6	Bit 5	Bit 4	Bit 3	Bit 2	Bit 1	Bit 0
Name	—	—	—	—	—	TFM	IBPV	—
Default	0	0	0	0	0	0	0	0

Bit 2: Transmit Frame Mode Select (TFM). In DS1 mode, this field specifies the DS1 framing mode. In E1 mode this field is unused and must be written with 0. See Section 7.10.5.2.

0 = ESF framing mode

1 = SF (D4) framing mode

Bit 1: Insert BPV (IBPV). A zero-to-one transition on this bit will cause a single bipolar violation (BPV) to be inserted into the transmit data stream. After this bit has been toggled from a 0 to a 1, the device waits for the next occurrence of three consecutive ones to insert the BPV. This bit must be cleared and set again for a subsequent error to be inserted. See Sections 7.10.5.2 and 7.10.6.2.

Register Name: BTCCR4
Register Description: BITS Transmit Configuration Register 4 (E1 only)
Register Address: 2Ah

	Bit 7	Bit 6	Bit 5	Bit 4	Bit 3	Bit 2	Bit 1	Bit 0
Name	TFPT	—	—	TSiS	—	THDB3	TAIS	TCRC4
Default	0	0	0	0	0	0	0	0

The fields of this register configure the transmit formatter when it is in E1 mode only (**BTMMR:TT1E1=1**). In DS1 mode this register is reserved and should not be written. See Section 7.10.6.2.

Bit 7: Transmit Time Slot 0 Formatter Pass-Through (TFPT). See Figure 7-16 for the relative priority of this control bit vs. other control fields.

- 0 = FAS bits/Si bits/Sa bits/RAI sourced internally from the **BTAF** and **BTNAF** registers
- 1 = FAS bits/Si bits/Sa bits/RAI sourced from TSER pin

Bit 4: Transmit International Bit Select (TSiS). See Figure 7-16 for the relative priority of this control bit vs. other transmit formatter control fields.

- 0 = Sample Si bits at TSER pin
- 1 = Source Si bits from the **BTAF** and **BTNAF** registers (in this mode, TFPT must be set to 0)

Bit 2: Transmit HDB3 Enable (THDB3).

- 0 = HDB3 encoding disabled
- 1 = HDB3 encoding enabled

Bit 1: Transmit Alarm Indication Signal (TAIS).

- 0 = Do not transmit AIS
- 1 = Transmit AIS (unframed all-ones)

Bit 0: Transmit CRC-4 Enable (TCRC4).

- 0 = CRC-4 framing mode disabled
- 1 = CRC-4 framing mode enabled

Register Name: BRIIR
Register Description: BITS Receive Interrupt Information Register
Register Address: 30h

	Bit 7	Bit 6	Bit 5	Bit 4	Bit 3	Bit 2	Bit 1	Bit 0
Name	—	<u>BRSR4</u>	—	—	—	—	<u>BRSR3</u>	<u>BRSR1</u>
Default	0	0	0	0	0	0	0	0

This register provide an indication of which BITS receive status registers have status bits set. When an interrupt request occurs, software can read BRIIR to quickly identify which of the BITS receive status registers might be causing the interrupt request. These bits clear once the appropriate interrupt request source has been serviced and cleared, as long as no other interrupt condition is present in the associated status register. Status bits that have been masked via the interrupt enable registers have no effect on these interrupt information bits.

Bit 6: BITS Receive Status Register 4 (BRSR4).

0 = No status bits set
 1 = Status bits set

Bit 1: BITS Receive Status Register 3 (BRSR3).

0 = No status bits set
 1 = Status bits set

Bit 0: BITS Receive Status Register 1 (BRSR1).

0 = No status bits set
 1 = Status bits set

Register Name: BRIR1
Register Description: BITS Receive Information Register 1 (DS1 and E1)
Register Address: 31h

	Bit 7	Bit 6	Bit 5	Bit 4	Bit 3	Bit 2	Bit 1	Bit 0
Name	—	—	—	—	<u>RAI</u>	<u>AIS</u>	<u>LOS</u>	<u>OOF</u>
Default	0	0	0	0	0	0	0	0

These fields provide real-time status information from the receive framer. See [Table 7-16](#) (DS1) and [Table 7-17](#) (E1) for set and clear criteria for RAI, AIS, LOS and OOF. The [BRSR1](#) register has corresponding latched status registers.

Bit 3: Remote Alarm Indication Condition (RAI).

0 = RAI not detected
 1 = RAI detected

Bit 2: Alarm Indication Signal Condition (AIS).

0 = AIS not detected
 1 = AIS detected

Bit 1: Loss of Signal Condition (LOS).

0 = LOS not detected
 1 = LOS detected

Bit 0: Out of Frame Condition (OOF).

0 = OOF not detected
 1 = OOF detected

Register Name: BRIR2
Register Description: BITS Receive Information Register 2 (E1 only)
Register Address: 32h

	Bit 7	Bit 6	Bit 5	Bit 4	Bit 3	Bit 2	Bit 1	Bit 0
Name	<u>CSC[5:2,0]</u>					<u>CRC4SA</u>	<u>CASSA</u>	<u>FASSA</u>
Default	0	0	0	0	0	0	0	0

The fields of this register provide real-time status information from the receive framer when it is in E1 mode only ([BRMMR:RT1E1=1](#)). In DS1 mode these fields are undefined. See Section [7.10.6.1](#).

Bits 7 to 3: CRC-4 Sync Counter bits (CSC[5:2] and CSC[0]). The CRC-4 sync counter increments each time the 8 ms CRC-4 multi-frame search times out. The counter is cleared when the framer has successfully obtained CRC-4 multiframe synchronization. The counter can also be cleared by disabling the CRC4 mode ([BRCCR3:RCRC4](#) = 0). This counter is useful for determining the amount of time the framer has been searching for synchronization at the CRC-4 level. ITU G.706 suggests that if synchronization at the CRC-4 level cannot be obtained within 400 ms, then the search should be abandoned and proper action taken. The CRC-4 sync counter rolls over when it reaches its maximum value. CSC[0] is the LSB of the 6-bit counter. (Note: The second LSB, CSC[1], is not accessible in this register to allow resolution to >400ms using 5 bits.)

Bit 2: FAS Sync Active (FASSA). This real-time information bit is set while the synchronizer is searching for alignment at the FAS level.

Bit 1: CAS MF Sync Active (CASSA). This real-time information bit is set while the synchronizer is searching for the CAS multi-frame alignment word.

Bit 0: CRC-4 MF Sync Active (CRC4SA). This real-time information bit is set while the synchronizer is searching for the CRC-4 multi-frame alignment word.

Register Name: BRSR1
Register Description: BITS Receive Status Register 1 (DS1 and E1)
Register Address: 33h

	Bit 7	Bit 6	Bit 5	Bit 4	Bit 3	Bit 2	Bit 1	Bit 0
Name	RAIC	AISC	LOSC	OOFC	RAI	AIS	LOS	OOF
Default	0	0	0	0	0	0	0	0

See [Table 7-16](#) (DS1) and [Table 7-17](#) (E1) for set and clear criteria for RAI, AIS, LOS and OOF.

Bit 7: Remote Alarm Indication Clear (RAIC). This latched status bit is set to 1 when [BRIR1:RAI](#) changes state from high to low. RAIC is cleared when written with a 1. When RAIC is set it can cause an interrupt request on the INTREQ pin if the RAIC interrupt enable bit is set in the [BRIER1](#) register.

Bit 6: Alarm Indication Signal Clear (AISC). This latched status bit is set to 1 when [BRIR1:AIS](#) changes state from high to low. AISC is cleared when written with a 1. When AISC is set it can cause an interrupt request on the INTREQ pin if the AISC interrupt enable bit is set in the [BRIER1](#) register.

Bit 5: Loss of Signal Clear (LOSC). This latched status bit is set to 1 when [BRIR1:LOS](#) changes state from high to low. LOSC is cleared when written with a 1. When LOSC is set it can cause an interrupt request on the INTREQ pin if the LOSC interrupt enable bit is set in the [BRIER1](#) register.

Bit 4: Out of Frame Clear (OOFC). This latched status bit is set to 1 when [BRIR1:OOF](#) changes state from high to low. OOFC is cleared when written with a 1. When OOFC is set it can cause an interrupt request on the INTREQ pin if the OOFC interrupt enable bit is set in the [BRIER1](#) register.

Bit 3: Remote Alarm Indication (RAI). This latched status bit is set to 1 when [BRIR1:RAI](#) changes state from low to high. RAI is cleared when written with a 1. When RAI is set it can cause an interrupt request on the INTREQ pin if the RAI interrupt enable bit is set in the [BRIER1](#) register.

Bit 2: Alarm Indication Signal (AIS). This latched status bit is set to 1 when [BRIR1:AIS](#) changes state from low to high. AIS is cleared when written with a 1. When AIS is set it can cause an interrupt request on the INTREQ pin if the AIS interrupt enable bit is set in the [BRIER1](#) register.

Bit 1: Loss of Signal (LOS). This latched status bit is set to 1 when [BRIR1:LOS](#) changes state from low to high. LOS is cleared when written with a 1. When LOS is set it can cause an interrupt request on the INTREQ pin if the LOS interrupt enable bit is set in the [BRIER1](#) register. See also the Receive Sensitivity paragraph in [Section 7.10.4.1.6](#).

Bit 0: Out of Frame (OOF). This latched status bit is set to 1 when [BRIR1:OOF](#) changes state from low to high. OOF is cleared when written with a 1. When OOF is set it can cause an interrupt request on the INTREQ pin if the OOF interrupt enable bit is set in the [BRIER1](#) register.

Register Name: BRIER1
Register Description: BITS Receive Interrupt Enable Register 1 (DS1 and E1)
Register Address: 34h

	Bit 7	Bit 6	Bit 5	Bit 4	Bit 3	Bit 2	Bit 1	Bit 0
Name	RAIC	AISC	LOSC	OOFC	RAI	AIS	LOS	OOF
Default	0	0	0	0	0	0	0	0

Bit 7: Interrupt Enable for Remote Alarm Indication Clear (RAIC). This bit is an interrupt enable for the RAIC bit in the [BRSR1](#) register.

- 0 = Mask the interrupt
- 1 = Enable the interrupt

Bit 6: Interrupt Enable for Alarm Indication Signal Clear (AISC). This bit is an interrupt enable for the AISC bit in the [BRSR1](#) register.

- 0 = Mask the interrupt
- 1 = Enable the interrupt

Bit 5: Interrupt Enable for Loss of Signal Clear (LOSC). This bit is an interrupt enable for the LOSC bit in the [BRSR1](#) register.

- 0 = Mask the interrupt
- 1 = Enable the interrupt

Bit 4: Interrupt Enable for Out of Frame Clear (OOFC). This bit is an interrupt enable for the OOFC bit in the [BRSR1](#) register.

- 0 = Mask the interrupt
- 1 = Enable the interrupt

Bit 3: Interrupt Enable for Remote Alarm Indication (RAI). This bit is an interrupt enable for the RAI bit in the [BRSR1](#) register.

- 0 = Mask the interrupt
- 1 = Enable the interrupt

Bit 2: Interrupt Enable for Alarm Indication Signal (AIS). This bit is an interrupt enable for the AIS bit in the [BRSR1](#) register.

- 0 = Mask the interrupt
- 1 = Enable the interrupt

Bit 1: Interrupt Enable for Loss of Signal (LOS). This bit is an interrupt enable for the LOS bit in the [BRSR1](#) register.

- 0 = Mask the interrupt
- 1 = Enable the interrupt

Bit 0: Interrupt Enable for Out of Frame (OOF). This bit is an interrupt enable for the OOF bit in the [BRSR1](#) register.

- 0 = Mask the interrupt
- 1 = Enable the interrupt

Register Name: BRSR2
Register Description: BITS Receive Status Register 2 (DS1 only)
Register Address: 35h

	Bit 7	Bit 6	Bit 5	Bit 4	Bit 3	Bit 2	Bit 1	Bit 0
Name	RPDV	—	COFA	8ZD	16ZD	SEFE	B8ZS	FBE
Default	0	0	0	0	0	0	0	0

The fields of this register provide latched status information from the receive framer when it is in DS1 mode (BRMMR:RT1E1=0). In E1 mode these fields are undefined. None of these latched status bits can cause an interrupt request. See Section 7.10.5.1.

Bit 7: Receive Pulse Density Violation Event (RPDV). This latched status bit is set to 1 when the incoming receive data stream does not meet the pulse density requirements of T1.403: no more than 15 consecutive zeros and at least N ones in each and every time window of $8 \times (N + 1)$ bits where $N = 1$ through 23. RPDV is cleared when written with a 1.

Bit 5: Change-of-Frame Alignment Event (COFA). This latched status bit is set to 1 when the last resync resulted in a change of frame or multiframe alignment. COFA is cleared when written with a 1.

Bit 4: Eight Zero Detect Event (8ZD). This latched status bit is set to 1 when a string of at least eight consecutive zeros (regardless of the length of the string) have been received in the incoming signal. 8ZD is cleared when written with a 1.

Bit 3: Sixteen Zero Detect Event (16ZD). This latched status bit is set to 1 when a string of at least 16 consecutive zeros (regardless of the length of the string) have been received in the incoming signal. 16ZD is cleared when written with a 1.

Bit 2: Severely Errored Framing Event (SEFE). This latched status bit is set to 1 when 2 out of 6 framing bits (Ft or FPS) are received in error. SEFE is cleared when written with a 1.

Bit 1: B8ZS Codeword Detect Event (B8ZS). This latched status bit is set to 1 when a B8ZS codeword is detected in the incoming signal, regardless of whether the B8ZS mode is selected or not. This bit enables systems to automatically setting the line coding. B8ZS is cleared when written with a 1.

Bit 0: Frame Bit Error Event (FBE). This latched status bit is set to 1 when an Ft (D4) or FPS (ESF) framing bit is received in error. FBE is cleared when written with a 1.

Register Name: BRSR3
Register Description: BITS Receive Status Register 3 (E1 only)
Register Address: 36h

	Bit 7	Bit 6	Bit 5	Bit 4	Bit 3	Bit 2	Bit 1	Bit 0
Name	—	CRCRC	CASRC	FASRC	RSA1	RSA0	RCMF	RAF
Default	0	0	0	0	0	0	0	0

The fields of this register provide latched status information from the receive framer when it is in E1 mode only ([BRMMR:RT1E1=1](#)). In DS1 mode these fields are undefined. See Section [7.10.6.1](#).

Bit 6: CRC-4 Resync Criteria Met (CRCRC). This latched status bit is set to 1 when 915 out of 1000 CRC-4 multiframe alignment words are received in error. CRCRC is cleared when written with a 1 and not set again until the CRC resync criteria is met again. CRCRC cannot cause an interrupt request.

Bit 5: CAS Resync Criteria Met (CASRC). This latched status bit is set to 1 when two consecutive CAS multi-frame alignment words are received in error. CASRC is cleared when written with a 1 and not set again until the CAS resync criteria is met again. CASRC cannot cause an interrupt request.

Bit 4: FAS Resync Criteria Met (FASRC). This latched status bit is set to 1 when three consecutive FAS words are received in error. FASRC is cleared when written with a 1 and not set again until the FAS resync criteria is met again. FASRC cannot cause an interrupt request.

Bit 3: Receive Signaling All Ones Event (RSA1). This latched status bit is set to 1 when timeslot 16 contains fewer than three zeros for 16 consecutive frames. RSA1 is cleared when written with a 1. When RSA1 is set it can cause an interrupt request on the INTREQ pin if the RSA1 interrupt enable bit is set in the [BRIER3](#) register. In all other modes RSA1 remains set to 0.

Bit 2: Receive Signaling All Zeros Event (RSA0). This latched status bit is set to 1 when timeslot 16 contains all zeros over a full multi-frame. RSA0 is cleared when written with a 1. When RSA0 is set it can cause an interrupt request on the INTREQ pin if the RSA0 interrupt enable bit is set in the [BRIER3](#) register. In all other modes RSA0 remains set to 0.

Bit 1: Receive CRC-4 Multi-Frame (RCMF). This latched status bit is set to 1 every 2 ms on CRC-4 multiframe boundaries. RCMF is cleared when written with a 1. When RCMF is set it can cause an interrupt request on the INTREQ pin if the RCMF interrupt enable bit is set in the [BRIER3](#) register. In all other modes RCMF remains set to 0. See Section [7.10.6.4](#).

Bit 0: Receive Align Frame (RAF). This latched status bit is set to 1 every 250 μ s at the beginning of align frames. RAF is cleared when written with a 1. When RAF is set it can cause an interrupt request on the INTREQ pin if the RAF interrupt enable bit is set in the [BRIER3](#) register. In all other modes RAF remains set to 0. See Section [7.10.6.3](#).

Register Name: BRIER3
Register Description: BITS Receive Interrupt Enable Register 3 (E1 only)
Register Address: 37h

	Bit 7	Bit 6	Bit 5	Bit 4	Bit 3	Bit 2	Bit 1	Bit 0
Name	—	—	—	—	RSA1	RSA0	RCMF	RAF
Default	0	0	0	0	0	0	0	0

The fields of this register configure interrupt masking for the corresponding bits in the [BRSR3](#) register when the receive framer is in E1 mode only ([BRMMR:RT1E1=1](#)). In DS1 mode this register is reserved and should not be written. See Section [7.10.6.1](#).

Bit 3: Interrupt Enable for Receive Signaling All Ones Event (RSA1). This bit is an interrupt enable for the RSA1 bit in the [BRSR3](#) register.

0 = Mask the interrupt

1 = Enable the interrupt

Bit 2: Interrupt Enable for Receive Signaling All Zeros Event (RSA0). This bit is an interrupt enable for the RSA0 bit in the [BRSR3](#) register.

0 = Mask the interrupt

1 = Enable the interrupt

Bit 1: Interrupt Enable for Receive CRC-4 Multi-Frame (RCMF). This bit is an interrupt enable for the RCMF bit in the [BRSR3](#) register.

0 = Mask the interrupt

1 = Enable the interrupt

Bit 0: Interrupt Enable for Receive Align Frame (RAF). This bit is an interrupt enable for the RAF bit in the [BRSR3](#) register.

0 = Mask the interrupt

1 = Enable the interrupt

Register Name: BRSR4
Register Description: BITS Receive Status Register 4 (DS1 only)
Register Address: 38h

	Bit 7	Bit 6	Bit 5	Bit 4	Bit 3	Bit 2	Bit 1	Bit 0
Name	—	—	—	—	—	—	BC	BD
Default	0	0	0	0	0	0	0	0

The fields of this register provide latched status information from the receive framer when it is in DS1 mode ([BRMMR:RT1E1=0](#)). In E1 mode these fields are undefined. See Section [7.10.5.3](#).

Bit 1: Receive BOC Clear (BC). This latched status bit is set to 1 when a valid BOC is no longer detected, with the disintegration filter applied as specified in [BRBCR:RBD\[1:0\]](#). BC is cleared when written with a 1. When BC is set it can cause an interrupt request on the INTREQ pin if the BC interrupt enable bit is set in the [BRIER4](#) register.

Bit 0: Receive BOC Detected (BD). This latched status bit is set to 1 when a valid BOC has been detected, with the validation filter applied as specified in [BRBCR:RBF](#). BD is cleared when written with a 1. When BD is set it can cause an interrupt request on the INTREQ pin if the BD interrupt enable bit is set in the [BRIER4](#) register.

Register Name: BRIER4
Register Description: BITS Interrupt Enable Register 4 (DS1 only)
Register Address: 39h

	Bit 7	Bit 6	Bit 5	Bit 4	Bit 3	Bit 2	Bit 1	Bit 0
Name	—	—	—	—	—	—	BC	BD
Default	0	0	0	0	0	0	0	0

Bit 1: Interrupt Enable for Receive BOC Clear (BC). This bit is an interrupt enable for the BC bit in the [BRSR4](#) register.

- 0 = Mask the interrupt
- 1 = Enable the interrupt

Bit 0: Interrupt Enable for Receive BOC Detected (BD). This bit is an interrupt enable for the BD bit in the [BRSR4](#) register.

- 0 = Mask the interrupt
- 1 = Enable the interrupt

Register Name: BTSR1
Register Description: BITS Transmit Status Register 1 (DS1 and E1)
Register Address: 3Ah

	Bit 7	Bit 6	Bit 5	Bit 4	Bit 3	Bit 2	Bit 1	Bit 0
Name	—	—	—	—	TPDV/TAF	TMF	LOTCC	LOTCC
Default	0	0	0	0	0	0	0	0

Bit 3: Transmit Pulse Density Violation (TPDV) / Transmit Align Frame (TAF). In DS1 mode this latched status bit functions as TPDV and is set to 1 when the transmit data stream does not meet the ANSI T1.403 requirements for pulse density: no more than 15 consecutive zeros and at least N ones in each and every time window of $8 \times (N + 1)$ bits where $N = 1$ through 23. In E1 mode this bit functions as TAF and is set to 1 every 250 μ s at the beginning of align frames. TPDV/TAF is cleared when written with a 1. When TPDV/TAF is set it can cause an interrupt to occur on the INTREQ pin if the TPDV/TAF interrupt enable bit is set in the [BTIER1](#) register. See Section 7.10.6.3.

Bit 2: Transmit Multi-Frame (TMF). In DS1 mode this latched status bit is set to 1 every 1.5 ms on superframe boundaries (SF mode) or every 3 ms on extended superframe boundaries (ESF mode). In E1 mode this bit is set every 2 ms on multiframe boundaries. TMF is cleared when written with a 1. When TMF is set it can cause an interrupt to occur on the INTREQ pin if the TMF interrupt enable bit is set in the [BTIER1](#) register. See Section 7.10.6.4.

Bit 1: Loss of Transmit Clock Clear (LOTCC). This latched status bit is set to 1 when the transmit clock source has transitioned for approximately 15 MCLK periods. LOTCC is cleared when written with a 1. When LOTCC is set it can cause an interrupt request on the INTREQ pin if the LOTCC interrupt enable bit is set in the [BTIER1](#) register.

Bit 0: Loss of Transmit Clock (LOTCC). This latched status bit is set to 1 when the transmit clock source has not transitioned for approximately 15 MCLK periods. LOTCC is cleared when written with a 1. When LOTCC is set it can cause an interrupt request on the INTREQ pin if the LOTCC interrupt enable bit is set in the [BTIER1](#) register.

Register Name: BTIER1
Register Description: BITS Transmit Interrupt Enable Register 1 (DS1 and E1)
Register Address: 3Bh

	Bit 7	Bit 6	Bit 5	Bit 4	Bit 3	Bit 2	Bit 1	Bit 0
Name	—	—	—	—	TPDV/TAF	TMF	LOTCC	LOTCC
Default	0	0	0	0	0	0	0	0

Bit 3: Interrupt Enable for Transmit Pulse Density Violation (TPDV) / Transmit Align Frame (TAF). This bit is an interrupt enable for the TPDV/TMF bit in the [BTSR1](#) register.

0 = Mask the interrupt

1 = Enable the interrupt

Bit 2: Interrupt Enable for Transmit Multi-Frame (TMF). This bit is an interrupt enable for the TMF bit in the [BTSR1](#) register.

0 = Mask the interrupt

1 = Enable the interrupt

Bit 1: Interrupt Enable for Loss of Transmit Clock Clear (LOTCC). This bit is an interrupt enable for the LOTCC bit in the [BTSR1](#) register.

0 = Mask the interrupt

1 = Enable the interrupt

Bit 0: Interrupt Enable for Loss of Transmit Clock (LOTCC). This bit is an interrupt enable for the LOTCC bit in the [BTSR1](#) register.

0 = Mask the interrupt

1 = Enable the interrupt

Register Name: BRBCR
Register Description: BITS Receive BOC Control Register (DS1 only)
Register Address: 40h

	Bit 7	Bit 6	Bit 5	Bit 4	Bit 3	Bit 2	Bit 1	Bit 0
Name	RBR	—	RBD[1:0]		RBF[2:0]			—
Default	0	0	0	0	0	0	0	0

When the BITS receive framer is in DS1 ESF mode this register configures the receive BOC controller. In E1 mode this register is reserved and should not be written. See Section 7.10.5.3.

Bit 7: Receive BOC Reset (RBR). A zero-to-one transition resets the BOC circuitry. RBR must be cleared and set again for a subsequent reset. Modifications to the RBF and RBD fields are not applied to the BOC controller until a BOC reset has been completed.

Bits 5 to 4: Receive BOC Disintegration Bits (RBD[1:0]). The receive BOC logic must examine the number of message bits specified by RBD[1:0] before declaring that a valid BOC is no longer detected. The BC bit in [BRSR4](#) is set to indicate that a valid BOC is no longer present.

RBD[1:0]	Consecutive Message Bits for BOC Clear
00	16
01	32
10	48
11	64

Bits 3 to 1: Receive BOC Filter Bits (RBF[2:0]). The receive BOC logic uses the criteria specified by this field to validate incoming BOC codes. The BD bit in [BRSR4](#) is set to indicate the detection of a validated BOC code.

RBF[2:0]	Validation Criteria for BOC Detected
000	1
001	3 in a row
010	5 in a row
011	7 in a row
100	7 out of 10

Register Name: BTBCR
Register Description: BITS Transmit BOC Control Register (DS1 only)
Register Address: 41h

	Bit 7	Bit 6	Bit 5	Bit 4	Bit 3	Bit 2	Bit 1	Bit 0
Name	—	SBOC	—	—	—	—	—	—
Default	0	0	0	0	0	0	0	0

When the BITS transmitter is in DS1 mode ESF mode this register configures the transmit BOC controller. In all other modes this register is reserved and should not be written. See Section 7.10.5.3.

Bit 6: Send BOC (SBOC).

0 = Do not transmit BOC codes

1 = Repeatedly transmit the BOC code stored in the [BTBOC](#) register

Register Name: BRBOC
Register Description: BITS Receive BOC Register (DS1 only)
Register Address: 42h

	Bit 7	Bit 6	Bit 5	Bit 4	Bit 3	Bit 2	Bit 1	Bit 0
Name	—	—	RBOC[5:0]					
Default	0	0	0	0	0	0	0	0

Bits 5 to 0: Receive BOC (RBOC[5:0]). DS1 ESF mode only. After a BOC has been validated per the criteria specified by [BRBCR:RBF](#), the BOC is stored in this field where it can be read by software. The device notifies software that a valid BOC is available by setting the BD bit in [BRSR4](#). Setting BD can optionally drive an interrupt request on the INTREQ pin. Bit 0 is the first bit received. See Section [7.10.5.3](#).

Register Name: BTBOC
Register Description: BITS Transmit BOC Register (DS1 only)
Register Address: 43h

	Bit 7	Bit 6	Bit 5	Bit 4	Bit 3	Bit 2	Bit 1	Bit 0
Name	—	—	TBOC[5:0]					
Default	0	0	0	0	0	0	0	0

Bits 5 to 0: Transmit BOC (TBOC[5:0]). DS1 ESF mode only. This field specifies the six data bits of the 16-bit BOC message to be transmitted in the ESF data link. When SBOC=1 in [BTBCR](#) the BOC is repeatedly transmitted on the data link. When SBOC=0, the data link idle code (01111110b = 7Eh) is transmitted continuously on the data link. Bit 0 is the first bit transmitted. See Section [7.10.5.3](#).

Register Name: BRAF
Register Description: BITS Receive Align Frame Register (E1 only)
Register Address: 50h

	Bit 7	Bit 6	Bit 5	Bit 4	Bit 3	Bit 2	Bit 1	Bit 0
Name	<u>Si</u>	<u>FAS[6:0]</u>						
Default	0	0	0	0	0	0	0	0

The align frame is the E1 frame containing the frame alignment signal (FAS). The bits of this register indicate the first eight bits received in the most recent align frame. The bits are latched into this register at the start of the align frame. The start of the align frame is indicated by the RAF status bit in [BRSR3](#). See Section 7.10.6.3.

Bit 7: International Bit (Si).

Bits 6 to 0: Frame Alignment Signal (FAS[6:0]). When a normal E1 signal is being received, FAS[6:0]=0011011.

Register Name: BRNAF
Register Description: BITS Receive Non-Align Frame Register (E1 only)
Register Address: 51h

	Bit 7	Bit 6	Bit 5	Bit 4	Bit 3	Bit 2	Bit 1	Bit 0
Name	<u>Si</u>	<u>1</u>	<u>RAI</u>	<u>Sa4</u>	<u>Sa5</u>	<u>Sa6</u>	<u>Sa7</u>	<u>Sa8</u>
Default	0	0	0	0	0	0	0	0

The non-align frame is the E1 frame that does not contain the frame alignment signal (FAS). The bits of this register indicate the first eight bits received in the most recent non-align frame. The bits are latched into this register at the start of the align frame. The start of the align frame is indicated by the RAF status bit in [BRSR3](#). See Section 7.10.6.3.

Bit 7: International Bit (Si).

Bit 6: Non-Align Frame Signal Bit. Set to 1 in a normal E1 double frame.

Bit 5: Remote Alarm Indication (RAI). This is the normal status bit for detecting RAI in the incoming E1 signal.

0 = No alarm condition

1 = Alarm condition

Bits 4 to 0: Additional Spare Bits (Sa4 to Sa8).

Register Name: BRSiAF
Register Description: BITS Receive Si Bits of the Align Frame (E1 only)
Register Address: 52h

	Bit 7	Bit 6	Bit 5	Bit 4	Bit 3	Bit 2	Bit 1	Bit 0
Name	<u>SiF14</u>	<u>SiF12</u>	<u>SiF10</u>	<u>SiF8</u>	<u>SiF6</u>	<u>SiF4</u>	<u>SiF2</u>	<u>SiF0</u>
Default	0	0	0	0	0	0	0	0

The align frame is the E1 frame containing the frame alignment signal (FAS). The bits of this register indicate the Si bits received in the align frames of the most recent CRC-4 multiframe. The Si bits received in each multiframe are saved in internal registers and latched into this register at the start of the next CRC-4 multiframe. The CRC-4 multiframe boundary is indicated by the RCMF status bit in [BRSR3](#). See Section [7.10.6.4](#).

Bit 7: Si Bit from Frame 14 (SiF14).
Bit 6: Si Bit from Frame 12 (SiF12).
Bit 5: Si Bit from Frame 10 (SiF10).
Bit 4: Si Bit from Frame 8 (SiF8).
Bit 3: Si Bit from Frame 6 (SiF6).
Bit 2: Si Bit from Frame 4 (SiF4).
Bit 1: Si Bit from Frame 2 (SiF2).
Bit 0: Si Bit from Frame 0 (SiF0).

Register Name: BRSiNAF
Register Description: BITS Receive Si Bits of the Non-Align Frame (E1 only)
Register Address: 53h

	Bit 7	Bit 6	Bit 5	Bit 4	Bit 3	Bit 2	Bit 1	Bit 0
Name	<u>SiF15</u>	<u>SiF13</u>	<u>SiF11</u>	<u>SiF9</u>	<u>SiF7</u>	<u>SiF5</u>	<u>SiF3</u>	<u>SiF1</u>
Default	0	0	0	0	0	0	0	0

The non-align frame is the E1 frame that does not contain the frame alignment signal (FAS). The bits of this register indicate the Si bits received in the non-align frames of the most recent CRC-4 multiframe. The Si bits received in each multiframe are saved in internal registers and latched into this register at the start of the next CRC-4 multiframe. The CRC-4 multiframe boundary is indicated by the RCMF status bit in [BRSR3](#). See Section [7.10.6.4](#).

Bit 7: Si Bit from Frame 15 (SiF15).
Bit 6: Si Bit from Frame 13 (SiF13).
Bit 5: Si Bit from Frame 11 (SiF11).
Bit 4: Si Bit from Frame 9 (SiF9).
Bit 3: Si Bit from Frame 7 (SiF7).
Bit 2: Si Bit from Frame 5 (SiF5).
Bit 1: Si Bit from Frame 3 (SiF3).
Bit 0: Si Bit from Frame 1 (SiF1).

Register Name: BRRAI
Register Description: BITS Receive Remote Alarm Indication Bits (E1 only)
Register Address: 54h

	Bit 7	Bit 6	Bit 5	Bit 4	Bit 3	Bit 2	Bit 1	Bit 0
Name	<u>RAIF15</u>	<u>RAIF13</u>	<u>RAIF11</u>	<u>RAIF9</u>	<u>RAIF7</u>	<u>RAIF5</u>	<u>RAIF3</u>	<u>RAIF1</u>
Default	0	0	0	0	0	0	0	0

The RAI bits received in each multiframe are saved in internal registers and latched into this register at the start of the next CRC-4 multiframe. The CRC-4 multiframe boundary is indicated by the RCMF status bit in [BRSR3](#). See Section [7.10.6.4](#).

Bit 7: RAI Bit from Frame 15 (RAIF15).

Bit 6: RAI Bit from Frame 13 (RAIF13).

Bit 5: RAI Bit from Frame 11 (RAIF11).

Bit 4: RAI Bit from Frame 9 (RAIF9).

Bit 3: RAI Bit from Frame 7 (RAIF7).

Bit 2: RAI Bit from Frame 5 (RAIF5).

Bit 1: RAI Bit from Frame 3 (RAIF3).

Bit 0: RAI Bit from Frame 1 (RAIF1).

Register Name: BRSA4
Register Description: BITS Receive Sa4 Bits (E1 only)
Register Address: 55h

	Bit 7	Bit 6	Bit 5	Bit 4	Bit 3	Bit 2	Bit 1	Bit 0
Name	<u>Sa4F15</u>	<u>Sa4F13</u>	<u>Sa4F11</u>	<u>Sa4F9</u>	<u>Sa4F7</u>	<u>Sa4F5</u>	<u>Sa4F3</u>	<u>Sa4F1</u>
Default	0	0	0	0	0	0	0	0

The Sa4 bits received in each multiframe are saved in internal registers and latched into this register at the start of the next CRC-4 multiframe. The CRC-4 multiframe boundary is indicated by the RCMF status bit in [BRSR3](#). See Section [7.10.6.4](#).

Bit 7: Sa4 Bit from Frame 15 (Sa4F15).

Bit 6: Sa4 Bit from Frame 13 (Sa4F13).

Bit 5: Sa4 Bit from Frame 11 (Sa4F11).

Bit 4: Sa4 Bit from Frame 9 (Sa4F9).

Bit 3: Sa4 Bit from Frame 7 (Sa4F7).

Bit 2: Sa4 Bit from Frame 5 (Sa4F5).

Bit 1: Sa4 Bit from Frame 3 (Sa4F3).

Bit 0: Sa4 Bit from Frame 1 (Sa4F1).

Register Name: BRSA5
Register Description: BITS Receive Sa5 Bits (E1 only)
Register Address: 56h

	Bit 7	Bit 6	Bit 5	Bit 4	Bit 3	Bit 2	Bit 1	Bit 0
Name	<u>Sa5F15</u>	<u>Sa5F13</u>	<u>Sa5F11</u>	<u>Sa5F9</u>	<u>Sa5F7</u>	<u>Sa5F5</u>	<u>Sa5F3</u>	<u>Sa5F1</u>
Default	0	0	0	0	0	0	0	0

The Sa5 bits received in each multiframe are saved in internal registers and latched into this register at the start of the next CRC-4 multiframe. The CRC-4 multiframe boundary is indicated by the RCMF status bit in [BRSR3](#). See Section [7.10.6.4](#).

Bit 7: Sa5 Bit from Frame 15 (Sa5F15).

Bit 6: Sa5 Bit from Frame 13 (Sa5F13).

Bit 5: Sa5 Bit from Frame 11 (Sa5F11).

Bit 4: Sa5 Bit from Frame 9 (Sa5F9).

Bit 3: Sa5 Bit from Frame 7 (Sa5F7).

Bit 2: Sa5 Bit from Frame 5 (Sa5F5).

Bit 1: Sa5 Bit from Frame 3 (Sa5F3).

Bit 0: Sa5 Bit from Frame 1 (Sa5F1).

Register Name: BRSA6
Register Description: BITS Receive Sa6 Bits (E1 only)
Register Address: 57h

	Bit 7	Bit 6	Bit 5	Bit 4	Bit 3	Bit 2	Bit 1	Bit 0
Name	<u>Sa6F15</u>	<u>Sa6F13</u>	<u>Sa6F11</u>	<u>Sa6F9</u>	<u>Sa6F7</u>	<u>Sa6F5</u>	<u>Sa6F3</u>	<u>Sa6F1</u>
Default	0	0	0	0	0	0	0	0

The Sa6 bits received in each multiframe are saved in internal registers and latched into this register at the start of the next CRC-4 multiframe. The CRC-4 multiframe boundary is indicated by the RCMF status bit in [BRSR3](#). See Section [7.10.6.4](#).

Bit 7: Sa6 Bit from Frame 15 (Sa6F15).

Bit 6: Sa6 Bit from Frame 13 (Sa6F13).

Bit 5: Sa6 Bit from Frame 11 (Sa6F11).

Bit 4: Sa6 Bit from Frame 9 (Sa6F9).

Bit 3: Sa6 Bit from Frame 7 (Sa6F7).

Bit 2: Sa6 Bit from Frame 5 (Sa6F5).

Bit 1: Sa6 Bit from Frame 3 (Sa6F3).

Bit 0: Sa6 Bit from Frame 1 (Sa6F1).

Register Name: BRSA7
Register Description: BITS Receive Sa7 Bits (E1 only)
Register Address: 58h

	Bit 7	Bit 6	Bit 5	Bit 4	Bit 3	Bit 2	Bit 1	Bit 0
Name	<u>Sa7F15</u>	<u>Sa7F13</u>	<u>Sa7F11</u>	<u>Sa7F9</u>	<u>Sa7F7</u>	<u>Sa7F5</u>	<u>Sa7F3</u>	<u>Sa7F1</u>
Default	0	0	0	0	0	0	0	0

The Sa7 bits received in each multiframe are saved in internal registers and latched into this register at the start of the next CRC-4 multiframe. The CRC-4 multiframe boundary is indicated by the RCMF status bit in [BRSR3](#). See Section [7.10.6.4](#).

Bit 7: Sa7 Bit from Frame 15 (Sa7F15).

Bit 6: Sa7 Bit from Frame 13 (Sa7F13).

Bit 5: Sa7 Bit from Frame 11 (Sa7F11).

Bit 4: Sa7 Bit from Frame 9 (Sa7F9).

Bit 3: Sa7 Bit from Frame 7 (Sa7F7).

Bit 2: Sa7 Bit from Frame 5 (Sa7F5).

Bit 1: Sa7 Bit from Frame 3 (Sa7F3).

Bit 0: Sa7 Bit from Frame 1 (Sa7F1).

Register Name: BRSA8
Register Description: BITS Receive Sa8 Bits (E1 only)
Register Address: 59h

	Bit 7	Bit 6	Bit 5	Bit 4	Bit 3	Bit 2	Bit 1	Bit 0
Name	<u>Sa8F15</u>	<u>Sa8F13</u>	<u>Sa8F11</u>	<u>Sa8F9</u>	<u>Sa8F7</u>	<u>Sa8F5</u>	<u>Sa8F3</u>	<u>Sa8F1</u>
Default	0	0	0	0	0	0	0	0

The Sa8 bits received in each multiframe are saved in internal registers and latched into this register at the start of the next CRC-4 multiframe. The CRC-4 multiframe boundary is indicated by the RCMF status bit in [BRSR3](#). See Section [7.10.6.4](#).

Bit 7: Sa8 Bit from Frame 15 (Sa8F15).

Bit 6: Sa8 Bit from Frame 13 (Sa8F13).

Bit 5: Sa8 Bit from Frame 11 (Sa8F11).

Bit 4: Sa8 Bit from Frame 9 (Sa8F9).

Bit 3: Sa8 Bit from Frame 7 (Sa8F7).

Bit 2: Sa8 Bit from Frame 5 (Sa8F5).

Bit 1: Sa8 Bit from Frame 3 (Sa8F3).

Bit 0: Sa8 Bit from Frame 1 (Sa8F1).

Register Name: BRMCR
Register Description: BITS Receive Message Control Register (E1 only)
Register Address: 5Ah

	Bit 7	Bit 6	Bit 5	Bit 4	Bit 3	Bit 2	Bit 1	Bit 0
Name	—	SSMCH[2:0]			—	—	SSMF[1:0]	
Default	0	0	0	0	0	0	0	0

Bits 6 to 4: Receive SSM Channel (SSMCH[2:0]). This field specifies the Sa-bit channel to look at when reading the most recently validated SSM message from [BRSSM:SSM\[3:0\]](#). After this field is changed, the SSM for the newly selected Sa bit channel does not appear in [BRSSM:SSM\[3:0\]](#) for approximately 250µs. See Section [7.10.6.5](#).

000 = Sa4
 001 = Sa5
 010 = Sa6
 011 = Sa7
 100 = Sa8

Bits 1 to 0: Receive SSM Filter (SSMF[1:0]). The logic that detects new SSM messages in the E1 Sa bits uses the criteria specified by this field to validate incoming SSM codes. The Sa4 through Sa8 fields in the [BRMSR](#) register are set to indicate the detection of a validated SSM code. See Section [7.10.6.5](#).

00 = Validate new SSM when present for 1 multiframe
 01 = Validate new SSM when present for 2 multiframes in a row
 10 = Validate new SSM when present for 3 multiframes in a row
 11 = Validate new SSM when present in 3 out of 4 consecutive multiframes

Register Name: BRMSR
Register Description: BITS Receive Message Status Register (E1 only)
Register Address: 5Bh

	Bit 7	Bit 6	Bit 5	Bit 4	Bit 3	Bit 2	Bit 1	Bit 0
Name	—		Sa8	—	Sa7	Sa6	Sa5	Sa4
Default	0	0	0	0	0	0	0	0

Bit 5: New Validated SSM in the Sa8 Bits (Sa8). This latched status bit is set to 1 when a new SSM message has been validated in the Sa8 channel according the criteria specified by [BRMCR:SSMF](#). When Sa8 is set it can cause an interrupt request on the INTREQ pin if the Sa8 interrupt enable bit is set in the [BRMCR](#) register. Sa8 is cleared when written with a 1 and not set again until another SSM change is validated in the Sa8 channel. See Section [7.10.6.5](#).

Bit 3: New Validated SSM in the Sa7 Bits (Sa7). This latched status bit is set to 1 when a new SSM message has been validated in the Sa7 channel according the criteria specified by [BRMCR:SSMF](#). When Sa7 is set it can cause an interrupt request on the INTREQ pin if the Sa7 interrupt enable bit is set in the [BRMCR](#) register. Sa7 is cleared when written with a 1 and not set again until another SSM change is validated in the Sa7 channel. See Section [7.10.6.5](#).

Bit 2: New Validated SSM in the Sa6 Bits (Sa6). This latched status bit is set to 1 when a new SSM message has been validated in the Sa6 channel according the criteria specified by [BRMCR:SSMF](#). When Sa6 is set it can cause an interrupt request on the INTREQ pin if the Sa6 interrupt enable bit is set in the [BRMCR](#) register. Sa6 is cleared when written with a 1 and not set again until another SSM change is validated in the Sa6 channel. See Section [7.10.6.5](#).

Bit 1: New Validated SSM in the Sa5 Bits (Sa5). This latched status bit is set to 1 when a new SSM message has been validated in the Sa5 channel according the criteria specified by [BRMCR:SSMF](#). When Sa5 is set it can cause an interrupt request on the INTREQ pin if the Sa5 interrupt enable bit is set in the [BRMCR](#) register. Sa5 is cleared when written with a 1 and not set again until another SSM change is validated in the Sa5 channel. See Section [7.10.6.5](#).

Bit 0: New Validated SSM in the Sa4 Bits (Sa4). This latched status bit is set to 1 when a new SSM message has been validated in the Sa4 channel according the criteria specified by [BRMCR:SSMF](#). When Sa4 is set it can cause an interrupt request on the INTREQ pin if the Sa4 interrupt enable bit is set in the [BRMCR](#) register. Sa4 is cleared when written with a 1 and not set again until another SSM change is validated in the Sa4 channel. See Section [7.10.6.5](#).

Register Name: BRMIER
Register Description: BITS Receive Message Interrupt Enable Register (E1 only)
Register Address: 5Ch

	Bit 7	Bit 6	Bit 5	Bit 4	Bit 3	Bit 2	Bit 1	Bit 0
Name	—	—	Sa8	—	Sa7	Sa6	Sa5	Sa4
Default	0	0	0	0	0	0	0	0

Bit 5: Interrupt Enable for Sa8 (Sa8). This bit is an interrupt enable for the Sa8 status bit in the [BRMSR](#) register.
 0 = Mask the interrupt
 1 = Enable the interrupt

Bit 3: Interrupt Enable for Sa7 (Sa7). This bit is an interrupt enable for the Sa7 status bit in the [BRMSR](#) register.
 0 = Mask the interrupt
 1 = Enable the interrupt

Bit 2: Interrupt Enable for Sa6 (Sa6). This bit is an interrupt enable for the Sa6 status bit in the [BRMSR](#) register.
 0 = Mask the interrupt
 1 = Enable the interrupt

Bit 1: Interrupt Enable for Sa5 (Sa5). This bit is an interrupt enable for the Sa5 status bit in the [BRMSR](#) register.
 0 = Mask the interrupt
 1 = Enable the interrupt

Bit 0: Interrupt Enable for Sa4 (Sa4). This bit is an interrupt enable for the Sa4 status bit in the [BRMSR](#) register.
 0 = Mask the interrupt
 1 = Enable the interrupt

Register Name: BRSSM
Register Description: BITS Receive SSM Register (E1 only)
Register Address: 5Dh

	Bit 7	Bit 6	Bit 5	Bit 4	Bit 3	Bit 2	Bit 1	Bit 0
Name	—	SSMCH[2:0]			SSM[3:0]			
Default	0	0	0	0	0	0	0	0

Bits 6 to 4: Receive SSM Channel (SSMCH[2:0]). This field specifies the Sa-bit channel for which the SSM bits are being displayed in the SSM[3:0] field. The value in this field matches the value in [BRMCR:SSMCH\[2:0\]](#) after a delay of approximately 250µs. See Section [7.10.6.5](#).

000 = Sa4
 001 = Sa5
 010 = Sa6
 011 = Sa7
 100 = Sa8

Bits 3 to 0: Receive SSM (SSM[3:0]). This read-only field contains the most recently validated SSM message from the Sa-bit channel indicated in [BRSSM:SSMCH\[2:0\]](#). The Sa bit channel to display in this field is specified by [BRMCR:SSMCH\[2:0\]](#). See Section [7.10.6.5](#).

Register Name: BTAF
Register Description: BITS Transmit Align Frame Register (E1 only)
Register Address: 60h

	Bit 7	Bit 6	Bit 5	Bit 4	Bit 3	Bit 2	Bit 1	Bit 0
Name	Si	FAS[6:0]						
Default	0	0	0	1	1	0	1	1

The align frame is the E1 frame containing the frame alignment signal (FAS). The bits of this register specify the first eight bits of the align frame. The bits are sampled from this register at the start of the align frame, which is indicated by the TAF status bit in [BTSR1](#). Various control fields can cause some of these bits to be sourced from elsewhere. See Section [7.10.6.3](#).

Bit 7: International Bit (Si).

Bits 6 to 0: Frame Alignment Signal (FAS[6:0]). Should be set to 0011011 for normal E1 operation.

Register Name: BTNAF
Register Description: BITS Transmit Non-Align Frame Register (E1 only)
Register Address: 61h

	Bit 7	Bit 6	Bit 5	Bit 4	Bit 3	Bit 2	Bit 1	Bit 0
Name	Si	1	RAI	Sa4	Sa5	Sa6	Sa7	Sa8
Default	0	1	0	0	0	0	0	0

The non-align frame is the E1 frame that does not contain the frame alignment signal (FAS). The bits of this register specify the first eight bits of the non-align frame.. The bits are sampled from this register at the start of the align frame, which is indicated by the TAF status bit in [BTSR1](#). Various control fields can cause some of these bits to be sourced from elsewhere. See Section [7.10.6.3](#).

Bit 7: International Bit (Si).

Bit 6: Non-Align Frame Signal Bit. Should be set to 1 for normal E1 operation.

Bit 5: Remote Alarm Indication (RAI). This is the normal control bit for manipulating the RAI bit in the outgoing E1 frames.

0 = No alarm condition

1 = Alarm condition

Bits 4 to 0: Additional Spare Bits (Sa4 to Sa8).

Register Name: BTSiAF
Register Description: BITS Transmit Si Bits of the Align Frame (E1 only)
Register Address: 62h

	Bit 7	Bit 6	Bit 5	Bit 4	Bit 3	Bit 2	Bit 1	Bit 0
Name	SiF14	SiF12	SiF10	SiF8	SiF6	SiF4	SiF2	SiF0
Default	0	0	0	0	0	0	0	0

The align frame is the E1 frame containing the frame alignment signal (FAS). When SiAF=1 in [BTOCR](#), the bits of this register specify the Si bits to be transmitted in the align frames of outgoing multiframes. The Si bits are sampled from this register at the start of the multiframe. The multiframe boundary is indicated by the TMF status bit in [BTSR1](#). See Section [7.10.6.4](#).

Bit 7: Si Bit of Frame 14 (SiF14).
Bit 6: Si Bit of Frame 12 (SiF12).
Bit 5: Si Bit of Frame 10 (SiF10).
Bit 4: Si Bit of Frame 8 (SiF8).
Bit 3: Si Bit of Frame 6 (SiF6).
Bit 2: Si Bit of Frame 4 (SiF4).
Bit 1: Si Bit of Frame 2 (SiF2).
Bit 0: Si Bit of Frame 0 (SiF0).

Register Name: BTSiNAF
Register Description: BITS Transmit Si Bits of the Non-Align Frame (E1 only)
Register Address: 63h

	Bit 7	Bit 6	Bit 5	Bit 4	Bit 3	Bit 2	Bit 1	Bit 0
Name	SiF15	SiF13	SiF11	SiF9	SiF7	SiF5	SiF3	SiF1
Default	0	0	0	0	0	0	0	0

The non-align frame is the E1 frame that does not contain the frame alignment signal (FAS). When SiNAF=1 in [BTOCR](#), the bits of this register specify the Si bits to be transmitted in the non-align frames of outgoing multiframes. The Si bits are sampled from this register at the start of the multiframe. The multiframe boundary is indicated by the TMF status bit in [BTSR1](#). See Section [7.10.6.4](#).

Bit 7: Si Bit of Frame 15 (SiF15).
Bit 6: Si Bit of Frame 13 (SiF13).
Bit 5: Si Bit of Frame 11 (SiF11).
Bit 4: Si Bit of Frame 9 (SiF9).
Bit 3: Si Bit of Frame 7 (SiF7).
Bit 2: Si Bit of Frame 5 (SiF5).
Bit 1: Si Bit of Frame 3 (SiF3).
Bit 0: Si Bit of Frame 1 (SiF1).

Register Name: BTRAI
Register Description: BITS Transmit Remote Alarm Indication Bits (E1 only)
Register Address: 64h

	Bit 7	Bit 6	Bit 5	Bit 4	Bit 3	Bit 2	Bit 1	Bit 0
Name	RAIF15	RAIF13	RAIF11	RAIF9	RAIF7	RAIF5	RAIF3	RAIF1
Default	0	0	0	0	0	0	0	0

When RAI=1 in [BTOCR](#), the bits of this register specify the RAI bits to be transmitted in outgoing multiframes. The RAI bits are sampled from this register at the start of the multiframe. The multiframe boundary is indicated by the TMF status bit in [BTSR1](#). See Section [7.10.6.4](#).

Bit 7: RAI Bit of Frame 15 (RAIF15).

Bit 6: RAI Bit of Frame 13 (RAIF13).

Bit 5: RAI Bit of Frame 11 (RAIF11).

Bit 4: RAI Bit of Frame 9 (RAIF9).

Bit 3: RAI Bit of Frame 7 (RAIF7).

Bit 2: RAI Bit of Frame 5 (RAIF5).

Bit 1: RAI Bit of Frame 3 (RAIF3).

Bit 0: RAI Bit of Frame 1 (RAIF1).

Register Name: BTSa4
Register Description: BITS Transmit Sa4 Bits (E1 only)
Register Address: 65h

	Bit 7	Bit 6	Bit 5	Bit 4	Bit 3	Bit 2	Bit 1	Bit 0
Name	Sa4F15	Sa4F13	Sa4F11	Sa4F9	Sa4F7	Sa4F5	Sa4F3	Sa4F1
Default	0	0	0	0	0	0	0	0

When Sa4=1 in [BTOCR](#), the bits of this register specify the Sa4 bits to be transmitted in outgoing multiframes. The Sa4 bits are sampled from this register at the start of the multiframe. The multiframe boundary is indicated by the TMF status bit in [BTSR1](#). See Section [7.10.6.4](#).

Bit 7: Sa4 Bit of Frame 15 (Sa4F15).

Bit 6: Sa4 Bit of Frame 13 (Sa4F13).

Bit 5: Sa4 Bit of Frame 11 (Sa4F11).

Bit 4: Sa4 Bit of Frame 9 (Sa4F9).

Bit 3: Sa4 Bit of Frame 7 (Sa4F7).

Bit 2: Sa4 Bit of Frame 5 (Sa4F5).

Bit 1: Sa4 Bit of Frame 3 (Sa4F3).

Bit 0: Sa4 Bit of Frame 1 (Sa4F1).

Register Name: BTSa5
Register Description: BITS Transmit Sa5 Bits (E1 only)
Register Address: 66h

	Bit 7	Bit 6	Bit 5	Bit 4	Bit 3	Bit 2	Bit 1	Bit 0
Name	Sa5F15	Sa5F13	Sa5F11	Sa5F9	Sa5F7	Sa5F5	Sa5F3	Sa5F1
Default	0	0	0	0	0	0	0	0

When Sa5=1 in [BTOCR](#), the bits of this register specify the Sa5 bits to be transmitted in outgoing multiframes. The Sa5 bits are sampled from this register at the start of the multiframe. The multiframe boundary is indicated by the TMF status bit in [BTSR1](#). See Section [7.10.6.4](#).

Bit 7: Sa5 Bit of Frame 15 (Sa5F15).

Bit 6: Sa5 Bit of Frame 13 (Sa5F13).

Bit 5: Sa5 Bit of Frame 11 (Sa5F11).

Bit 4: Sa5 Bit of Frame 9 (Sa5F9).

Bit 3: Sa5 Bit of Frame 7 (Sa5F7).

Bit 2: Sa5 Bit of Frame 5 (Sa5F5).

Bit 1: Sa5 Bit of Frame 3 (Sa5F3).

Bit 0: Sa5 Bit of Frame 1 (Sa5F1).

Register Name: BTSa6
Register Description: BITS Transmit Sa6 Bits (E1 only)
Register Address: 67h

	Bit 7	Bit 6	Bit 5	Bit 4	Bit 3	Bit 2	Bit 1	Bit 0
Name	Sa6F15	Sa6F13	Sa6F11	Sa6F9	Sa6F7	Sa6F5	Sa6F3	Sa6F1
Default	0	0	0	0	0	0	0	0

When Sa6=1 in [BTOCR](#), the bits of this register specify the Sa6 bits to be transmitted in outgoing multiframes. The Sa6 bits are sampled from this register at the start of the multiframe. The multiframe boundary is indicated by the TMF status bit in [BTSR1](#). See Section [7.10.6.4](#).

Bit 7: Sa6 Bit of Frame 15 (Sa6F15).

Bit 6: Sa6 Bit of Frame 13 (Sa6F13).

Bit 5: Sa6 Bit of Frame 11 (Sa6F11).

Bit 4: Sa6 Bit of Frame 9 (Sa6F9).

Bit 3: Sa6 Bit of Frame 7 (Sa6F7).

Bit 2: Sa6 Bit of Frame 5 (Sa6F5).

Bit 1: Sa6 Bit of Frame 3 (Sa6F3).

Bit 0: Sa6 Bit of Frame 1 (Sa6F1).

Register Name: BTSa7
Register Description: BITS Transmit Sa7 Bits (E1 only)
Register Address: 68h

	Bit 7	Bit 6	Bit 5	Bit 4	Bit 3	Bit 2	Bit 1	Bit 0
Name	Sa7F15	Sa7F13	Sa7F11	Sa7F9	Sa7F7	Sa7F5	Sa7F3	Sa7F1
Default	0	0	0	0	0	0	0	0

When Sa7=1 in [BTOCR](#), the bits of this register specify the Sa7 bits to be transmitted in outgoing multiframes. The Sa7 bits are sampled from this register at the start of the multiframe. The multiframe boundary is indicated by the TMF status bit in [BTSR1](#). See Section [7.10.6.4](#).

Bit 7: Sa7 Bit of Frame 15 (Sa7F15).

Bit 6: Sa7 Bit of Frame 13 (Sa7F13).

Bit 5: Sa7 Bit of Frame 11 (Sa7F11).

Bit 4: Sa7 Bit of Frame 9 (Sa7F9).

Bit 3: Sa7 Bit of Frame 7 (Sa7F7).

Bit 2: Sa7 Bit of Frame 5 (Sa7F5).

Bit 1: Sa7 Bit of Frame 3 (Sa7F3).

Bit 0: Sa7 Bit of Frame 1 (Sa7F1).

Register Name: BTSa8
Register Description: BITS Transmit Sa8 Bits (E1 only)
Register Address: 69h

	Bit 7	Bit 6	Bit 5	Bit 4	Bit 3	Bit 2	Bit 1	Bit 0
Name	Sa8F15	Sa8F13	Sa8F11	Sa8F9	Sa8F7	Sa8F5	Sa8F3	Sa8F1
Default	0	0	0	0	0	0	0	0

When Sa8=1 in [BTOCR](#), the bits of this register specify the Sa8 bits to be transmitted in outgoing multiframes. The Sa8 bits are sampled from this register at the start of the multiframe. The multiframe boundary is indicated by the TMF status bit in [BTSR1](#). See Section [7.10.6.4](#).

Bit 7: Sa8 Bit of Frame 15 (Sa8F15).

Bit 6: Sa8 Bit of Frame 13 (Sa8F13).

Bit 5: Sa8 Bit of Frame 11 (Sa8F11).

Bit 4: Sa8 Bit of Frame 9 (Sa8F9).

Bit 3: Sa8 Bit of Frame 7 (Sa8F7).

Bit 2: Sa8 Bit of Frame 5 (Sa8F5).

Bit 1: Sa8 Bit of Frame 3 (Sa8F3).

Bit 0: Sa8 Bit of Frame 1 (Sa8F1).

Register Name: BTOCR
Register Description: BITS Transmit Overhead Control Register (E1 only)
Register Address: 6Ah

	Bit 7	Bit 6	Bit 5	Bit 4	Bit 3	Bit 2	Bit 1	Bit 0
Name	SiAF	SiNAF	RAI	Sa4	Sa5	Sa6	Sa7	Sa8
Default	0	0	0	0	0	0	0	0

When set to 1 these control bits have precedence over any other source of Si/RAI/Sa bits, including the CRC-4 Si bit generation logic. See Section 7.10.6.

Bit 7: Si In Align Frame Data Source (SiAF).

- 0 = Do not source the Si bits in the align frame from the [BTSiAF](#) register
- 1 = Source the Si bits in the align frame from the [BTSiAF](#) register

Bit 6: Si In Non-Align Frame Data Source (SiNAF).

- 0 = Do not source the Si bits in the non-align frame from the [BTSiNAF](#) register
- 1 = Source the Si bits in the non-align frame from the [BTSiNAF](#) register

Bit 5: RAI Data Source (RAI).

- 0 = Do not source the RAI bits from the [BTRAI](#) register
- 1 = Source the RAI bits from the [BTRAI](#) register

Bit 4: Sa4 Data Source (Sa4).

- 0 = Do not source the Sa4 bits from the [BTSa4](#) register
- 1 = Source the Sa4 bits from the [BTSa4](#) register

Bit 3: Sa5 Data Source (Sa5).

- 0 = Do not source the Sa5 bits from the [BTSa5](#) register
- 1 = Source the Sa5 bits from the [BTSa5](#) register

Bit 2: Sa6 Data Source (Sa6).

- 0 = Do not source the Sa6 bits from the [BTSa6](#) register
- 1 = Source the Sa6 bits from the [BTSa6](#) register

Bit 1: Sa7 Data Source (Sa7).

- 0 = Do not source the Sa7 bits from the [BTSa7](#) register
- 1 = Source the Sa7 bits from the [BTSa7](#) register

Bit 0: Sa8 Data Source (Sa8).

- 0 = Do not source the Sa8 bits from the [BTSa8](#) register
- 1 = Source the Sa8 bits from the [BTSa8](#) register

9. JTAG TEST ACCESS PORT AND BOUNDARY SCAN

9.1 JTAG Description

The DS3100 supports the standard instruction codes SAMPLE/PRELOAD, BYPASS, and EXTEST. Optional public instructions included are HIGHZ, CLAMP, and IDCODE. Figure 9-1 shows a block diagram. The DS3100 contains the following items, which meet the requirements set by the IEEE 1149.1 Standard Test Access Port and Boundary Scan Architecture:

Test Access Port (TAP)	Bypass Register
TAP Controller	Boundary Scan Register
Instruction Register	Device Identification Register

The TAP has the necessary interface pins, namely JTCLK, \overline{JTRST} , JTDI, JTDO, and JTMS. Details on these pins can be found in Table 6-8. Details about the boundary scan architecture and the TAP can be found in IEEE 1149.1-1990, IEEE 1149.1a-1993, and IEEE 1149.1b-1994.

Figure 9-1. JTAG Block Diagram

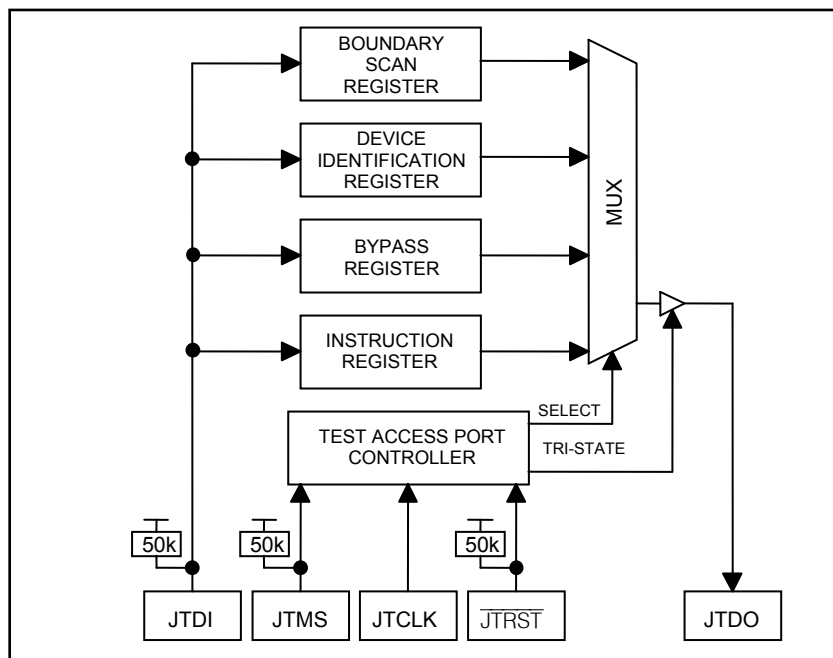

9.2 JTAG TAP Controller State Machine Description

This section discusses the operation of the TAP controller state machine. The TAP controller is a finite state machine that responds to the logic level at JTMS on the rising edge of JTCLK. Each of the states denoted in [Figure 9-2](#) are described in the following paragraphs.

Test-Logic-Reset. Upon device power-up, the TAP controller starts in the Test-Logic-Reset state. The instruction register contains the IDCODE instruction. All system logic on the device operates normally.

Run-Test-Idle. Run-Test-Idle is used between scan operations or during specific tests. The instruction register and all test registers remain idle.

Select-DR-Scan. All test registers retain their previous state. With JTMS low, a rising edge of JTCLK moves the controller into the Capture-DR state and initiates a scan sequence. JTMS high moves the controller to the Select-IR-SCAN state.

Capture-DR. Data can be parallel-loaded into the test register selected by the current instruction. If the instruction does not call for a parallel load or the selected test register does not allow parallel loads, the register remains at its current value. On the rising edge of JTCLK, the controller goes to the Shift-DR state if JTMS is low or to the Exit1-DR state if JTMS is high.

Shift-DR. The test register selected by the current instruction is connected between JTDI and JTDO and data is shifted one stage toward the serial output on each rising edge of JTCLK. If a test register selected by the current instruction is not placed in the serial path, it maintains its previous state.

Exit1-DR. While in this state, a rising edge on JTCLK with JTMS high puts the controller in the Update-DR state, which terminates the scanning process. A rising edge on JTCLK with JTMS low puts the controller in the Pause-DR state.

Pause-DR. Shifting of the test registers is halted while in this state. All test registers selected by the current instruction retain their previous state. The controller remains in this state while JTMS is low. A rising edge on JTCLK with JTMS high puts the controller in the Exit2-DR state.

Exit2-DR. While in this state, a rising edge on JTCLK with JTMS high puts the controller in the Update-DR state and terminates the scanning process. A rising edge on JTCLK with JTMS low puts the controller in the Shift-DR state.

Update-DR. A falling edge on JTCLK while in the Update-DR state latches the data from the shift register path of the test registers into the data output latches. This prevents changes at the parallel output because of changes in the shift register. A rising edge on JTCLK with JTMS low puts the controller in the Run-Test-Idle state. With JTMS high, the controller enters the Select-DR-Scan state.

Select-IR-Scan. All test registers retain their previous state. The instruction register remains unchanged during this state. With JTMS low, a rising edge on JTCLK moves the controller into the Capture-IR state and initiates a scan sequence for the instruction register. JTMS high during a rising edge on JTCLK puts the controller back into the Test-Logic-Reset state.

Capture-IR. The Capture-IR state is used to load the shift register in the instruction register with a fixed value. This value is loaded on the rising edge of JTCLK. If JTMS is high on the rising edge of JTCLK, the controller enters the Exit1-IR state. If JTMS is low on the rising edge of JTCLK, the controller enters the Shift-IR state.

Shift-IR. In this state, the instruction register's shift register is connected between JTDI and JTDO and shifts data one stage for every rising edge of JTCLK toward the serial output. The parallel register and the test registers remain at their previous states. A rising edge on JTCLK with JTMS high moves the controller to the Exit1-IR state. A rising edge on JTCLK with JTMS low keeps the controller in the Shift-IR state, while moving data one stage through the instruction shift register.

Exit1-IR. A rising edge on JTCLK with JTMS low puts the controller in the Pause-IR state. If JTMS is high on the rising edge of JTCLK, the controller enters the Update-IR state and terminates the scanning process.

Pause-IR. Shifting of the instruction register is halted temporarily. With JTMS high, a rising edge on JTCLK puts the controller in the Exit2-IR state. The controller remains in the Pause-IR state if JTMS is low during a rising edge on JTCLK.

Exit2-IR. A rising edge on JTCLK with JTMS high puts the controller in the Update-IR state. The controller loops back to the Shift-IR state if JTMS is low during a rising edge of JTCLK in this state.

Update-IR. The instruction shifted into the instruction shift register is latched into the parallel output on the falling edge of JTCLK as the controller enters this state. Once latched, this instruction becomes the current instruction. A rising edge on JTCLK with JTMS low puts the controller in the Run-Test-Idle state. With JTMS high, the controller enters the Select-DR-Scan state.

Figure 9-2. JTAG TAP Controller State Machine

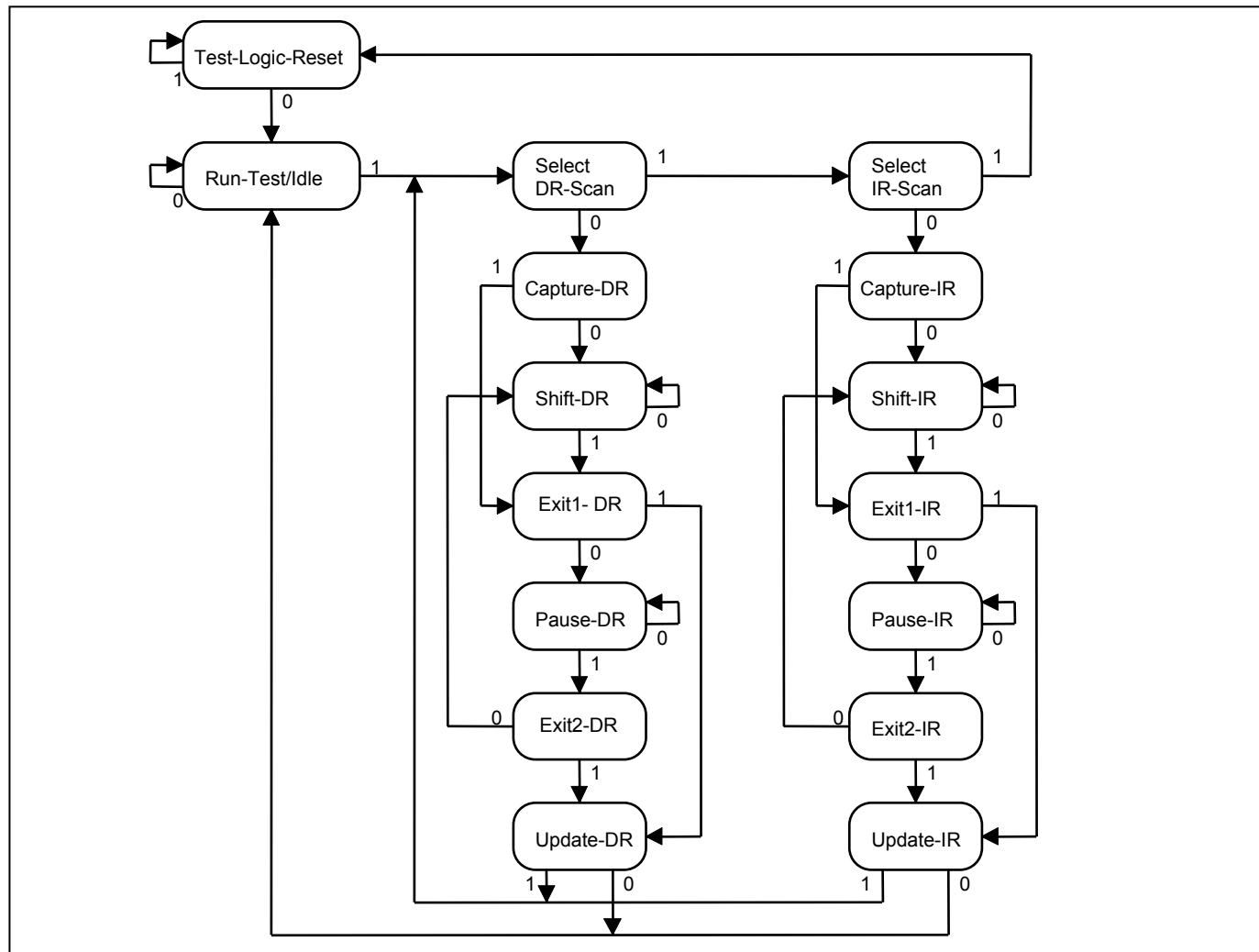

9.3 JTAG Instruction Register and Instructions

The instruction register contains a shift register as well as a latched parallel output and is 3 bits in length. When the TAP controller enters the Shift-IR state, the instruction shift register is connected between JTDI and JTDO. While in the Shift-IR state, a rising edge on JTCLK with JTMS low shifts data one stage toward the serial output at JTDO. A rising edge on JTCLK in the Exit1-IR state or the Exit2-IR state with JTMS high moves the controller to the Update-IR state. The falling edge of that same JTCLK latches the data in the instruction shift register to the instruction parallel output. Table 9-1 shows the instructions supported by the DS3100 and their respective operational binary codes.

Table 9-1. JTAG Instruction Codes

INSTRUCTIONS	SELECTED REGISTER	INSTRUCTION CODES
SAMPLE/PRELOAD	Boundary Scan	010
BYPASS	Bypass	111
EXTEST	Boundary Scan	000
CLAMP	Bypass	011
HIGHZ	Bypass	100
IDCODE	Device Identification	001

SAMPLE/PRELOAD. SAMPLE/RELOAD is a mandatory instruction for the IEEE 1149.1 specification. This instruction supports two functions. First, the digital I/Os of the device can be sampled at the boundary scan register, using the Capture-DR state, without interfering with the device's normal operation. Second, data can be shifted into the boundary scan register through JTDI using the Shift-DR state.

EXTEST. EXTEST allows testing of the interconnections to the device. When the EXTEST instruction is latched in the instruction register, the following actions occur: (1) Once the EXTEST instruction is enabled through the Update-IR state, the parallel outputs of the digital output pins are driven. (2) The boundary scan register is connected between JTDI and JTDO. (3) The Capture-DR state samples all digital inputs into the boundary scan register.

BYPASS. When the BYPASS instruction is latched into the parallel instruction register, JTDI is connected to JTDO through the 1-bit bypass register. This allows data to pass from JTDI to JTDO without affecting the device's normal operation.

IDCODE. When the IDCODE instruction is latched into the parallel instruction register, the device identification register is selected. The device ID code is loaded into the device identification register on the rising edge of JTCLK, following entry into the Capture-DR state. Shift-DR can be used to shift the ID code out serially through JTDO. During Test-Logic-Reset, the ID code is forced into the instruction register's parallel output.

HIGHZ. All digital outputs are placed into a high-impedance state. The bypass register is connected between JTDI and JTDO.

CLAMP. All digital output pins output data from the boundary scan parallel output while connecting the bypass register between JTDI and JTDO. The outputs do not change during the CLAMP instruction.

9.4 JTAG Test Registers

IEEE 1149.1 requires a minimum of two test registers—the bypass register and the boundary scan register. An optional test register, the identification register, has been included in the device design. It is used with the IDCODE instruction and the Test-Logic-Reset state of the TAP controller.

Bypass Register. This is a single 1-bit shift register used with the BYPASS, CLAMP, and HIGHZ instructions to provide a short path between JTDI and JTDO.

Boundary Scan Register. This register contains a shift register path and a latched parallel output for control cells and digital I/O cells. BSDL files are available at www.maxim-ic.com/TechSupport/telecom/bsdl.htm.

Identification Register. This register contains a 32-bit shift register and a 32-bit latched parallel output. It is selected during the IDCODE instruction and when the TAP controller is in the Test-Logic-Reset state. The device identification code for the DS3100 is shown in Table 9-2.

Table 9-2. JTAG ID Code

DEVICE	REVISION	DEVICE CODE	MANUFACTURER CODE	REQUIRED
DS3100	Consult factory	000000000011100	00010100001	1

10. ELECTRICAL CHARACTERISTICS

ABSOLUTE MAXIMUM RATINGS

Voltage Range on Any Pin with Respect to V_{SS} (except V_{DD})	-0.3V to +5.5V
Supply Voltage Range (V_{DD}) with Respect to V_{SS}	-0.3V to +1.98V
Supply Voltage Range (V_{DDIO}) with Respect to V_{SS}	-0.3V to +3.63V
Ambient Operating Temperature Range	-40°C to +85°C (Note 1)
Junction Operating Temperature Range	-40°C to +125°C
Storage Temperature Range	-55°C to +125°C
Soldering Temperature	See IPC/JEDEC J-STD-020 Specification

Note 1: Specifications to -40°C are guaranteed by design and not production tested.

Stresses beyond those listed under "Absolute Maximum Ratings" may cause permanent damage to the device. These are stress ratings only, and functional operation of the device at these or any other conditions beyond those indicated in the operational sections of the specifications is not implied. Exposure to the absolute maximum rating conditions for extended periods may affect device. Ambient operating temperature range when device is mounted on a four-layer JEDEC test board with no airflow.

10.1 DC Characteristics

Table 10-1. Recommended DC Operating Conditions

($T_A = -40^\circ\text{C}$ to $+85^\circ\text{C}$)

PARAMETER	SYMBOL	CONDITIONS	MIN	TYP	MAX	UNITS
Supply Voltage, Core	V_{DD}		1.62	1.8	1.98	V
Supply Voltage, I/O	V_{DDIO}		3.135	3.3	3.465	V
Ambient Temperature Range	T_A		-40		+85	°C

Table 10-2. DC Characteristics

($V_{DD} = 1.8\text{V} \pm 10\%$, $V_{DDIO} = 3.3\text{V} \pm 5\%$, $T_A = -40^\circ\text{C}$ to $+85^\circ\text{C}$.)

PARAMETER	SYMBOL	CONDITIONS	MIN	TYP	MAX	UNITS
Supply Current	1.8V	I_{DD18}	(Note 2)	129	152	mA
	1.8V	I_{DD18}	(Note 3)	130	154	
	3.3V	I_{DD33}	(Note 2)	36	53	
	3.3V	I_{DD33}	(Note 3)	124	145	
Supply Current Reduction When One BITS Transmitter is Powered Down	I_{DDR1}	BLCR4:TPD = 1		35		mA
Supply Current Reduction When One BITS Receiver is Powered Down	I_{DDR2}	BLCR4:RPD = 1		9		mA
Supply Current from V_{DD_OC6} When output OC6 is Enabled	I_{DDOC6}	(Note 4)		8		mA
Supply Current from V_{DD_OC7} When output OC7 is Enabled	I_{DDOC7}	(Note 4)		8		mA
Input Capacitance	C_{IN}			5		pF
Output Capacitance	C_{OUT}			7		pF

Note 2: 12.800MHz clock applied to REFCLK. Both BITS transceivers shut down, 19.44MHz clock applied to one CMOS/TTL input clock pin. One 19.44MHz CMOS/TTL output clock pin driving 100pF load; all other inputs at V_{DDIO} or grounded; all other outputs open.

Note 3: 12.800MHz clock applied to REFCLK. Both BITS transceivers enabled in E1 mode, transmitting and receiving over 75Ω cables through recommended transformers and external circuitry. 19.44MHz clock applied to one CMOS/TTL input clock pin. One 19.44MHz CMOS/TTL output clock pin driving 100pF load; all other inputs at V_{DDIO} or grounded; all other outputs open.

Note 4: 19.44MHz output clock frequency, driving the load shown in [Figure 10-1](#).

Table 10-3. CMOS/TTL Pins(V_{DD} = 1.8V ±10%, V_{DDIO} = 3.3V ±5%, T_A = -40°C to +85°C.)

PARAMETER	SYMBOL	CONDITIONS	MIN	TYP	MAX	UNITS
Input High Voltage	V _{IH}		2.0		5.5	V
Input Low Voltage	V _{IL}		-0.3		+0.8	V
Input Leakage	I _{IL}	(Note 1)	-10		+10	μA
Input Leakage, Pins with Internal Pullup Resistor (50kΩ typical)	I _{ILPU}	(Note 1)	-85		+10	μA
Input Leakage, Pins with Internal Pulldown Resistor (50kΩ typical)	I _{ILPD}	(Note 1)	-10		+85	μA
Output Leakage (when High Impedance)	I _{LO}	(Note 1)	-10		+10	μA
Output High Voltage (I _O = -4.0mA)	V _{OH}		2.4		V _{DDIO}	V
Output Low Voltage (I _O = +4.0mA)	V _{OL}		0		0.4	V

Note 1: 0V < V_{IN} < V_{DDIO} for all other digital inputs.**Table 10-4. LVDS Pins**(V_{DD} = 1.8V ±10%, V_{DDIO} = 3.3V ±5%, T_A = -40°C to +85°C.) (See [Figure 10-1.](#))

PARAMETER	SYMBOL	CONDITIONS	MIN	TYP	MAX	UNITS
Input Voltage Range	V _{INLVDS}	V _{IDLVDS} = 100mV	0		2.4	V
Differential Input Voltage	V _{IDLVDS}		0.1		1.4	V
Differential Input Logic Threshold	V _{THLVDS}		-100		+100	mV
Output High Voltage	V _{OHLVDS}	(Note 1)		1.45	1.65	V
Output Low Voltage	V _{OLLVDS}	(Note 1)	0.885	1.1		V
Differential Output Voltage	V _{ODLVDS}		250		450	mV
Output Offset Voltage (Common Mode Voltage)	V _{OSLVDS}	+25°C (Note 1)	1.08	1.28	1.45	V
Difference in Magnitude of Output Differential Voltage for Complementary States	V _{DOSLVDS}				25	mV

Note 1: With 100Ω load across the differential outputs.**Note 2:** The DS3100's LVDS output pins can easily be interfaced to LVPECL and CML inputs on neighboring ICs using a few external passive components. See [Maxim App Note HFAN-1.0](#) for details.**Figure 10-1. Recommended Termination for LVDS Pins**

Table 10-5. LVPECL Pins

($V_{DD} = 1.8V \pm 10\%$, $V_{DDIO} = 3.3V \pm 5\%$, $T_A = -40^\circ\text{C}$ to $+85^\circ\text{C}$) (See [Figure 10-2.](#))

PARAMETER	SYMBOL	CONDITIONS	MIN	TYP	MAX	UNITS
Input High Voltage, Differential Inputs	V_{IHPECL}	(Note 1)	$V_{DDIO} - 2.4$		$V_{DDIO} - 0.4$	V
Input Low Voltage, Differential Inputs	V_{ILPECL}	(Note 1)	$V_{DDIO} - 2.5$		$V_{DDIO} - 0.5$	V
Input Differential Voltage	V_{IDPECL}		0.1		1.4	V
Input High Voltage, Single-Ended Inputs	$V_{IHPECL,S}$	(Note 2)	$V_{DDIO} - 1.3$		$V_{DDIO} - 0.5$	V
Input Low Voltage, Single-Ended Inputs	$V_{ILPECL,S}$	(Note 2)	$V_{DDIO} - 2.4$		$V_{DDIO} - 1.5$	V

Note 1: For a differential input voltage $\geq 100\text{mV}$.

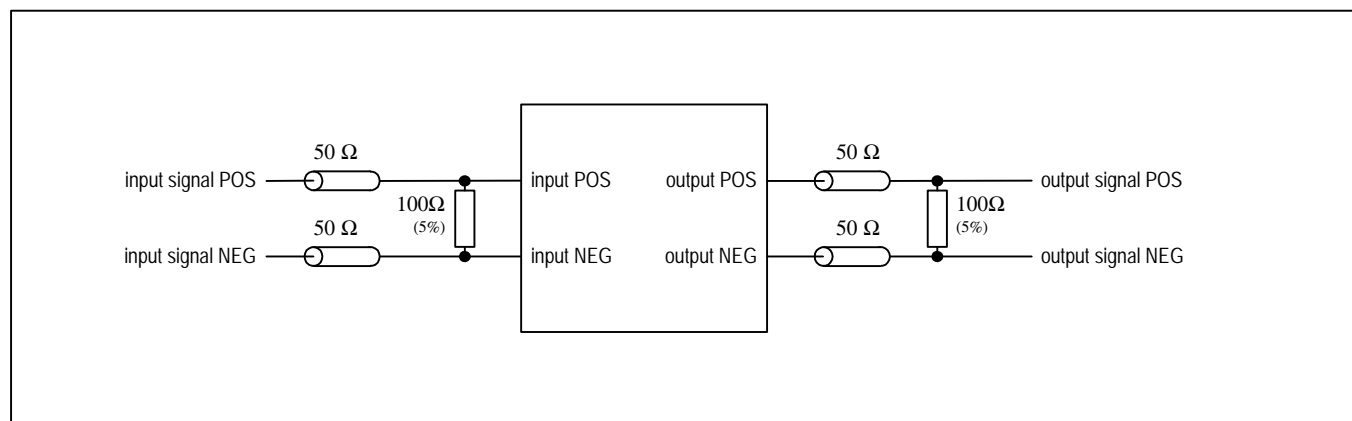
Note 2: With the unused differential input tied to $V_{DDIO} - 1.4\text{V}$.

Note 3: Although the DS3100's differential outputs do not directly drive standard LVPECL signals, these output pins can easily be interfaced to LVPECL and CML inputs on neighboring ICs using a few external passive components. See [Maxim App Note HFAN-1.0](#) for details.

Figure 10-2. Recommended Termination for LVPECL Pins

Table 10-6. AMI Composite Clock Pins(V_{DD} = 1.8V ±10%, V_{DDIO} = 3.3V ±5%, T_A = -40°C to +85°C.) (Note 1) (See Figure 10-3.)

PARAMETER	SYMBOL	CONDITIONS	MIN	TYP	MAX	UNITS
Input High Voltage	V _{IHAM1}		2.2		V _{DDIO} + 0.3	V
Input Middle Voltage	V _{IMAMI}		1.5	1.65	1.8	V
Input Low Voltage	V _{ILAMI}		-0.3		1.1	V
Input LOS Threshold	V _{LOS}	At the IC1/IC2 pin		0.2		V
Input Pulse Width	t _{PW}		1.6	7.8	14	μs
Input Rise/Fall Time	t _R , t _F				0.5	μs

Note 1: The timing parameters in this table are guaranteed by design (GBD).**Figure 10-3. Recommended External Components for AMI Composite Clock Pins**

For input CC signals compliant with Telcordia GR-378 (amplitude 2.7V to 5.5V) or ITU G.703 Section 4.2.2 option b) (3V±0.5V), the signal should be attenuated by a factor of 3 (or more) before being presented to IC1A or IC2A. Input CC signals with a 1V nominal pulse amplitude can be presented unattenuated.

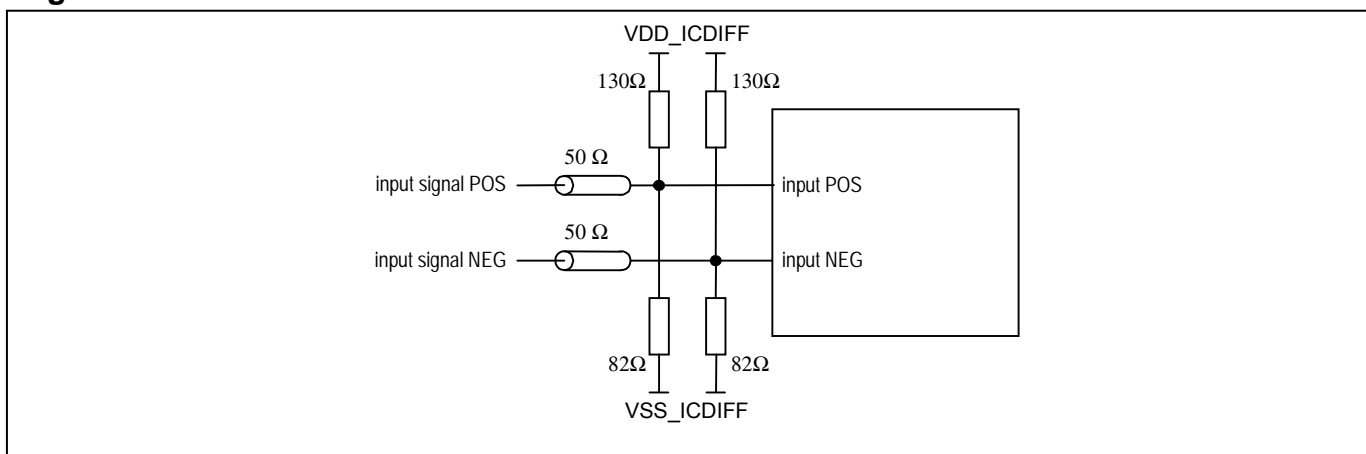
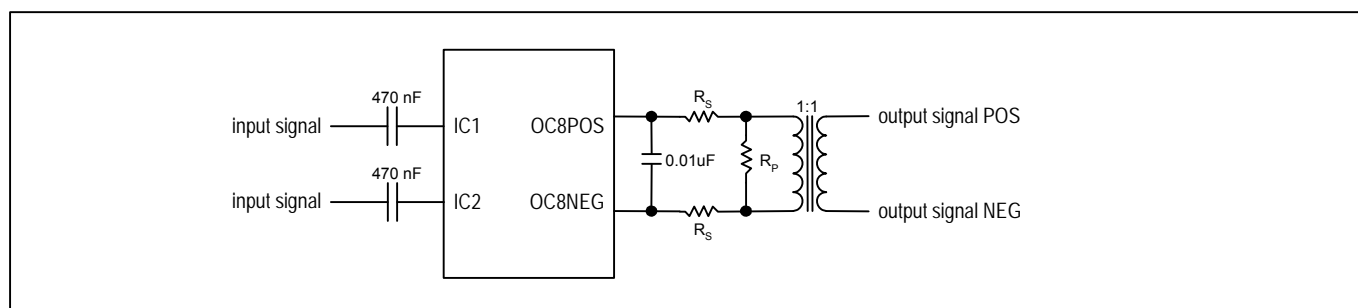
For output CC signals, Table 10-7 specifies recommended values for the components in Figure 10-3. Recommended transformers include the PE-65540 from Pulse Engineering.

Table 10-7. Recommended External Components for Output Clock OC8

SIGNAL TYPE	R _S	R _P
GR-378 (133Ω, 2.7V–5.5V)	0	open
G.703 4.2.2 option b) (110Ω, 3V ± 0.5V)	0	open
G.703 4.2.2 option a) and Appendix II.1 (110Ω, 1V ± 0.1V)	91Ω	360Ω
G.703 4.2.3 (120Ω, 1V ± 0.1V)	91Ω	300Ω

10.2 Input Clock Timing

Table 10-8. Input Clock Timing

($V_{DD} = 1.8V \pm 10\%$, $V_{DDIO} = 3.3V \pm 5\%$, $T_A = -40^\circ C$ to $+85^\circ C$.)

PARAMETER	SYMBOL	MIN	TYP	MAX
Input Clock Period, CMOS/TTL Input Pins	t_{CYC}	8ns (125MHz)		500 μ s (2kHz)
Input Clock Period, LVDS/LVPECL Input Pins	t_{CYC}	6.43ns (155.52MHz)		500 μ s (2kHz)
Input Clock High, Low Time	t_H, t_L	3ns or 30% of t_{CYC} , whichever is smaller		

10.3 Output Clock Timing

Table 10-9. Input Clock to Output Clock Delay

INPUT FREQUENCY	OUTPUT FREQUENCY	DELAY, INPUT CLOCK EDGE TO OUTPUT CLOCK EDGE
8kHz	8kHz	0.0 ± 1.5 ns
6.48MHz	6.48MHz	-12 ± 1.5 ns
19.44MHz	19.44MHz	0.0 ± 1.5 ns
25.92MHz	25.92MHz	0.0 ± 1.5 ns
38.88MHz	38.88MHz	0.0 ± 1.5 ns
51.84MHz	51.84MHz	0.0 ± 1.5 ns
77.76MHz	77.76MHz	0.0 ± 1.5 ns
155.52MHz	155.52MHz	0.0 ± 1.5 ns

Table 10-10. Output Clock Phase Alignment, Frame Sync Alignment Mode

OUTPUT FREQUENCY	DELAY, OC1 (2kHz) FALLING EDGE TO OUTPUT CLOCK FALLING EDGE
8kHz (OC10)	0.0 ± 0.5 ns
2kHz	0.0 ± 0.5 ns
8kHz	0.0 ± 0.5 ns
1.544MHz (OC9)	0.0 ± 1.25 ns
2.048MHz (OC9)	0.0 ± 1.25 ns
44.736MHz	-2.0 ± 1.25 ns
34.368MHz	-2.0 ± 1.25 ns
6.48MHz	-2.0 ± 1.25 ns
19.44MHz	-2.0 ± 1.25 ns
25.92MHz	-2.0 ± 1.25 ns
38.88MHz	-2.0 ± 1.25 ns
51.84MHz	-2.0 ± 1.25 ns
77.76MHz	-2.0 ± 1.25 ns
155.52MHz	-2.0 ± 1.25 ns
311.04MHz	-2.0 ± 1.25 ns

See Section 7.9.3 for details on frame sync alignment and the SYNC2K pin.

10.4 BITS Transceiver Timing

Table 10-11. BITS Receiver Timing

($V_{DD} = 1.8V \pm 10\%$, $V_{DDIO} = 3.3V \pm 5\%$, $T_A = -40^{\circ}C$ to $+85^{\circ}C$.) (Note 1) (See [Figure 10-4](#).)

PARAMETER	SYMBOL	CONDITIONS	MIN	TYP	MAX	UNITS
RCLK Period	t_{CP}	(Note 2)		488		ns
		(Note 3)		648		
		(Note 4)		158.4		
RCLK Duty Cycle			45%	50%	55%	ns
RCLK to RSER Delay	t_{OD1}				50	ns
RCLK to ROUT Delay	t_{OD2}				50	ns
RCLK, RSER and ROUT Rise and Fall Times	t_R, t_F	(Note 5)			10	ns
ROUT Pulse Width	t_{ROPW}		50			ns

Note 1: The timing parameters in this table are guaranteed by design (GBD).

Note 2: E1 or 2048kHz mode.

Note 3: DS1mode.

Note 4: 6312kHz mode.

Note 5: 100pF load.

Figure 10-4. BITS Receiver Timing Diagram

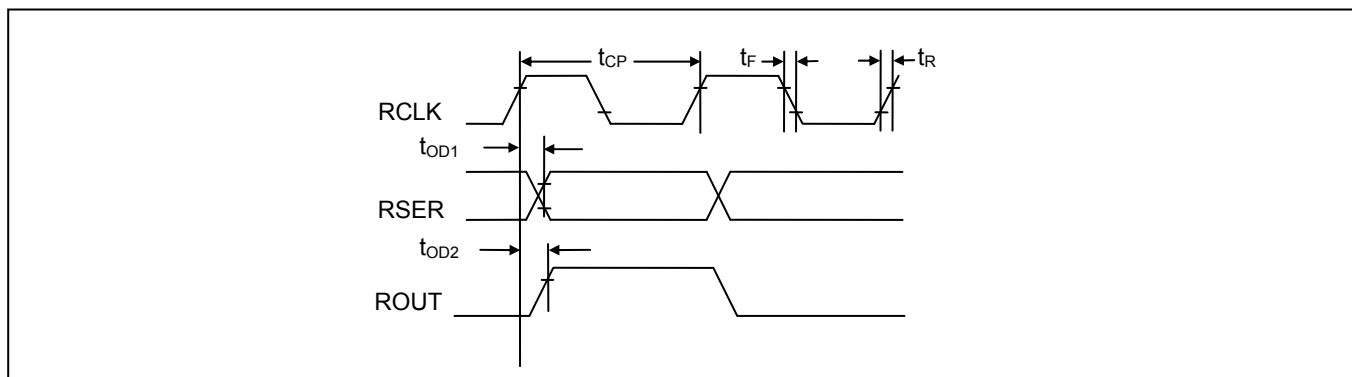

Table 10-12. BITS Transmitter Timing

($V_{DD} = 1.8V \pm 10\%$, $V_{DDIO} = 3.3V \pm 5\%$, $T_A = -40^\circ\text{C}$ to $+85^\circ\text{C}$.) (Note 1) (See Figure 10-5.)

PARAMETER	SYMBOL	CONDITIONS	MIN	TYP	MAX	UNITS
TCLK Period	t_{CP}	(Note 2)		488		ns
		(Note 3)		648		
TCLK High Time	t_{CH}		125			ns
TCLK Low Time	t_{CL}		125			ns
TSER, TIN Rise and Fall Times	t_R, t_F				20	ns
TSER, TIN to TCLK Setup Time	t_{SU}		20		$t_{CH} - 5$	ns
TSER, TIN to TCLK Hold Time	t_{HD}		20			ns
TCLK to TOUT Delay	t_{OD}				50	ns
TCLK, TOUT Rise and Fall Times	t_R, t_F	(Note 4)			10	ns

Note 1: The timing parameters in this table are guaranteed by design (GBD).

Note 2: E1 or 2048kHz mode.

Note 3: DS1mode.

Note 4: 100pF load.

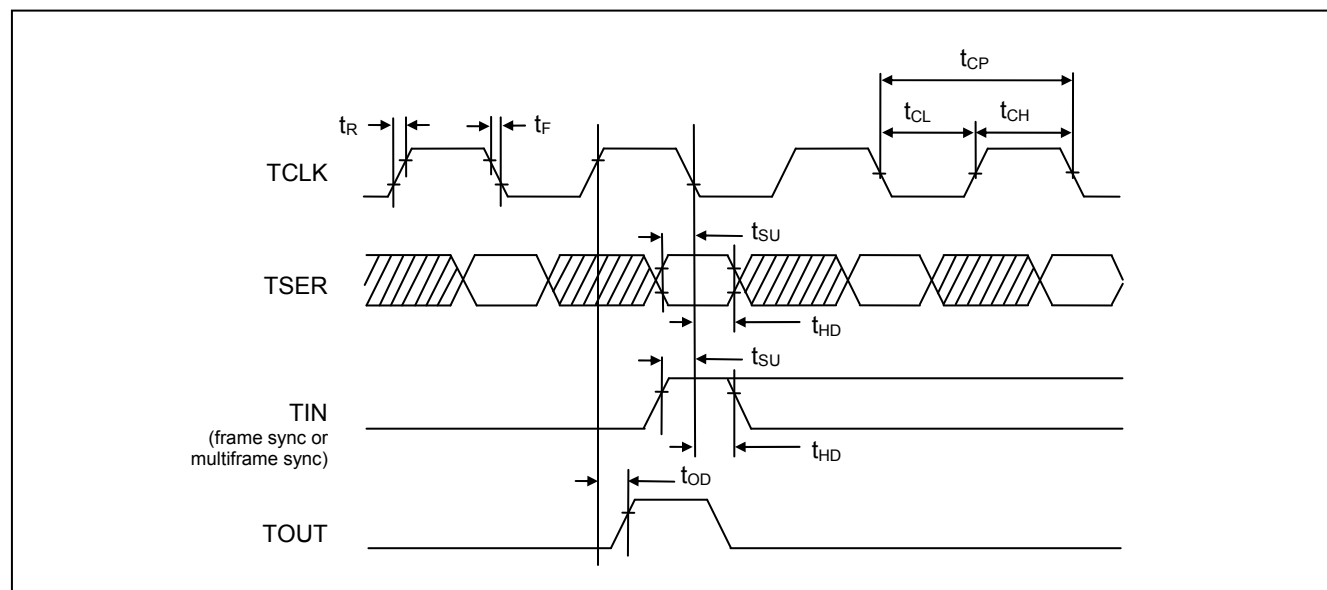
Figure 10-5. BITS Transmitter Timing Diagram

10.5 Parallel Interface Timing

Table 10-13. Parallel Interface Timing

($V_{DD} = 1.8V \pm 10\%$, $V_{DDIO} = 3.3V \pm 5\%$, $T_A = -40^\circ C$ to $+85^\circ C$.) (Note 1) (See [Figure 10-6](#) and [Figure 10-7](#).)

PARAMETER	SYMBOL	CONDITIONS	MIN	TYP	MAX	UNITS
Address Setup to \overline{RD} , \overline{WR} , \overline{DS} Active	t1a	(Note 2)	10			ns
ALE Setup to \overline{RD} , \overline{WR} , \overline{DS} Active	t1b	(Notes 2, 3)	10			ns
Address Setup to ALE Inactive	t2	(Notes 2, 3)	2			ns
Address Hold from ALE Inactive	t3	(Notes 2, 3)	2			ns
ALE Pulse Width	t4	(Notes 2, 3)	5			ns
Address Hold from \overline{RD} , \overline{WR} , \overline{DS} Inactive	t5	(Note 2)	0			ns
\overline{CS} Setup to \overline{RD} , \overline{WR} , \overline{DS} Active	t6	(Note 2)	0			ns
Data Valid from \overline{RD} , \overline{DS} Active	t8	(Note 2)			80	ns
\overline{RD} , \overline{WR} , \overline{DS} Pulse Width if not Using \overline{RDY} Handshake	t9a	(Notes 2, 4)	90			ns
\overline{RD} , \overline{WR} , \overline{DS} Delay from \overline{RDY} Active	t9b	(Note 2)	15			ns
Data Output High Impedance from \overline{RD} , \overline{DS} Inactive	t10	(Notes 2, 5)	2		10	ns
Data Output Enabled from \overline{RD} , \overline{DS} Active	t11	(Note 2)	2			ns
\overline{CS} Hold from \overline{RD} , \overline{WR} , \overline{DS} Inactive	t12	(Note 2)	0			ns
Data Setup to \overline{WR} , \overline{DS} Inactive	t13	(Note 2)	10			ns
Data Hold from \overline{WR} , \overline{DS} inactive	t14	(Note 2)	5			ns
\overline{RDY} Active from \overline{RD} , \overline{WR} , \overline{DS} Active	t15	(Note 2)	10			ns
\overline{RDY} Inactive from \overline{RD} , \overline{WR} , \overline{DS} Inactive	t16	(Note 2)	0		10	ns
\overline{RDY} Output Enabled from \overline{CS} Active	t17	(Note 2)			10	ns
\overline{RDY} Output High Impedance from \overline{CS} Inactive	t18	(Note 2)			10	ns
\overline{RDY} Ending High Pulse Width	t19	(Note 2)	2			ns
$\overline{R/W}$ Setup to \overline{DS} Active	t20	(Note 2)	2			ns
$\overline{R/W}$ Hold from \overline{DS} Inactive	t21	(Note 2)	2			ns

Note 1: The timing parameters in this table are guaranteed by design (GBD).

Note 2: The input/output timing reference level for all signals is $V_{DD}/2$. Transition time (80/20%) on \overline{RD} , \overline{WR} , and \overline{CS} inputs is 5ns max.

Note 3: Multiplexed mode timing only.

Note 4: Timing required if not using \overline{RDY} handshake.

Note 5: D[7:0] output valid until not driven.

Figure 10-6. Parallel Interface Timing Diagram (Nonmultiplexed)

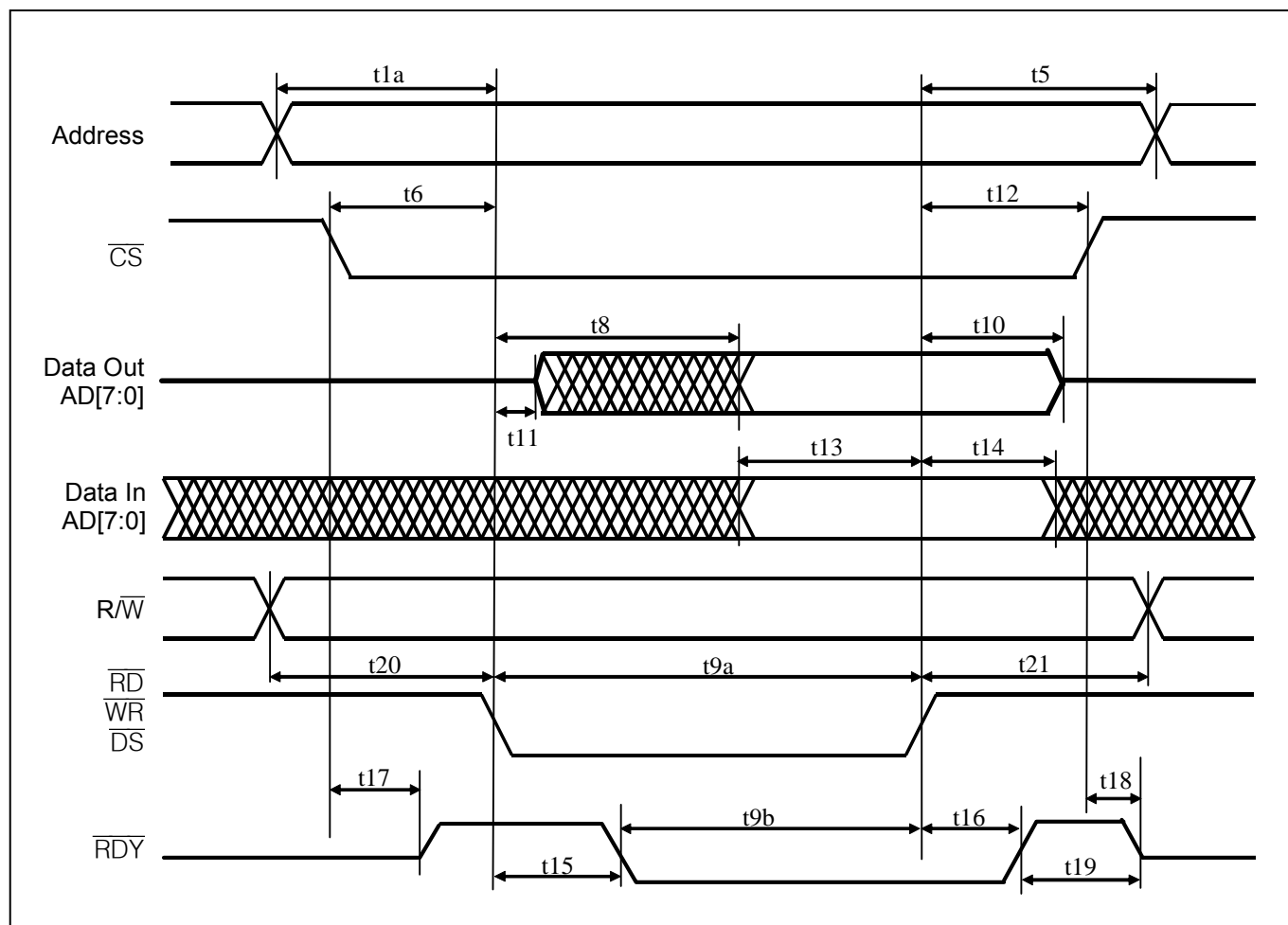
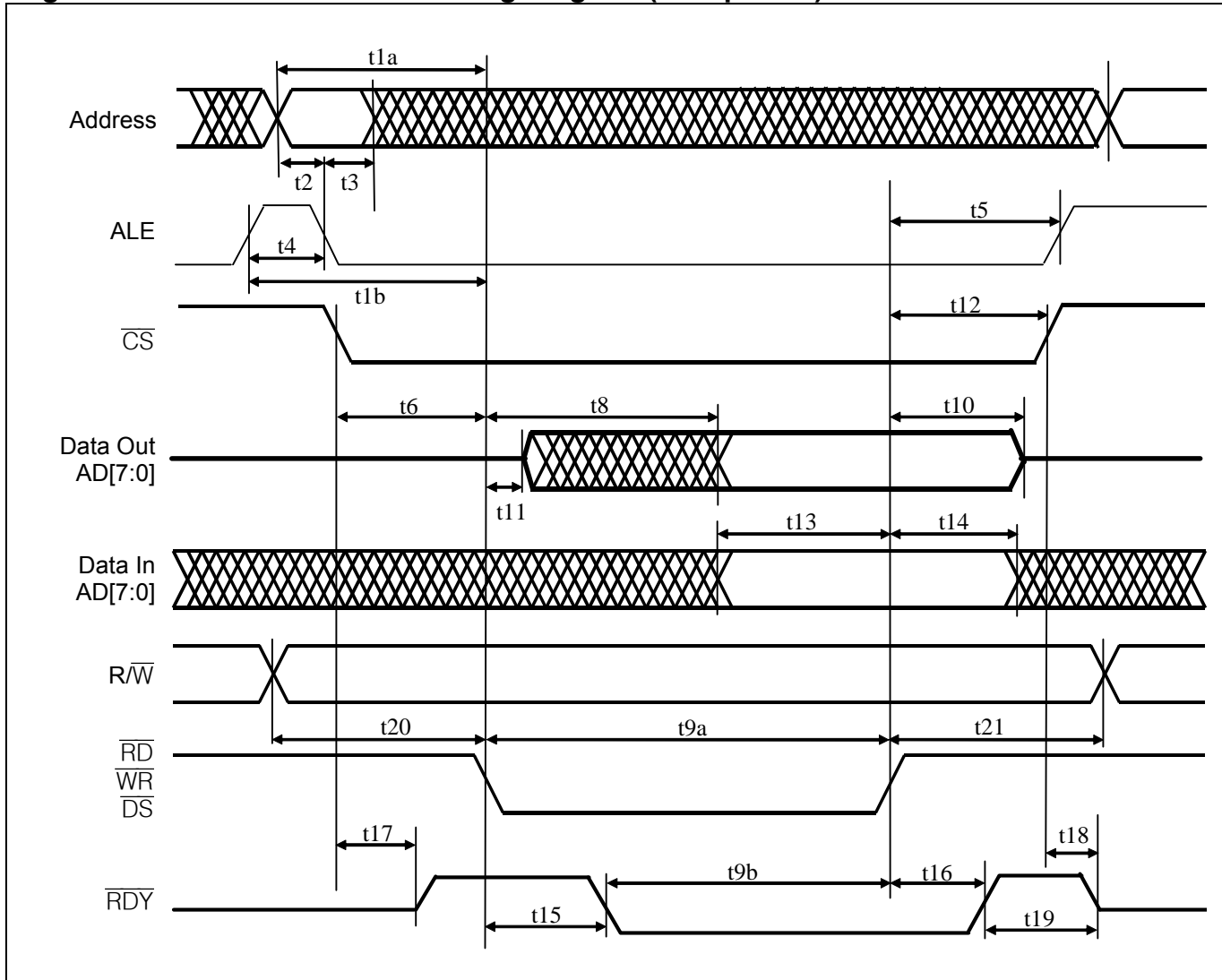

Figure 10-7. Parallel Interface Timing Diagram (Multiplexed)



10.6 SPI Interface Timing

Table 10-14. SPI Interface Timing

($V_{DD} = 1.8V \pm 10\%$, $V_{DDIO} = 3.3V \pm 5\%$, $T_A = -40^\circ C$ to $+85^\circ C$.) (Note 1) (See Figure 10-8.)

PARAMETER (Note 2)	SYMBOL	MIN	TYP	MAX	UNITS
SCLK Frequency	f_{BUS}			6	MHz
SCLK Cycle Time	t_{CYC}	166			ns
\overline{CS} Setup to First SCLK Edge	t_{SUC}	15			ns
\overline{CS} Hold time After Last SCLK Edge	t_{HDC}	15			ns
SCLK High Time	t_{CLKH}	80			ns
SCLK Low Time	t_{CLKL}	80			ns
SDI Data Setup Time	t_{SUI}	5			ns
SDI Data Hold Time	t_{HDI}	15			ns
SDO Enable Time (High-Impedance to Output Active)	t_{EN}	0			ns
SDO Disable Time (Output Active to High Impedance)	t_{DIS}			25	ns
SDO Data Valid Time	t_{DV}			40	ns
SDO Data Hold Time After Update SCLK Edge	t_{HDO}	5			ns

Note 1: The timing parameters in this table are guaranteed by design (GBD).

Note 2: All timing is specified with 100 pF load on all SPI pins.

Figure 10-8. SPI Interface Timing Diagram

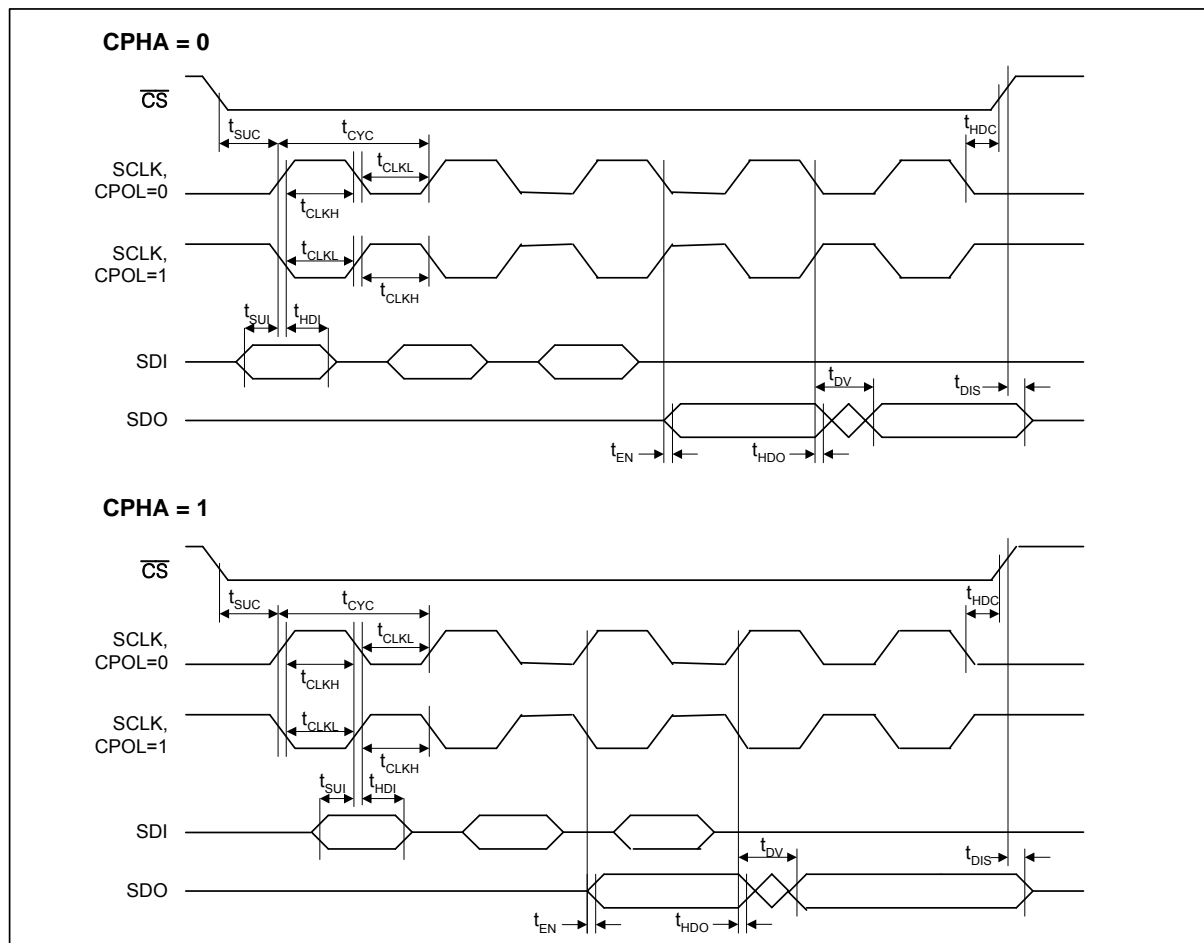

10.7 JTAG Interface Timing

Table 10-15. JTAG Interface Timing

($V_{DD} = 1.8V \pm 10\%$, $V_{DDIO} = 3.3V \pm 5\%$, $T_A = -40^{\circ}C$ to $+85^{\circ}C$.) (Note 1) (See [Figure 10-9](#).)

PARAMETER	SYMBOL	MIN	TYP	MAX	UNITS
JTCLK Clock Period	t1		1000		ns
JTCLK Clock High/Low Time (Note 2)	t2/t3	50	500		ns
JTCLK to JTDI, JTMS Setup Time	t4	50			ns
JTCLK to JTDI, JTMS Hold Time	t5	50			ns
JTCLK to JTDO Delay	t6	2		50	ns
JTCLK to JTDO High-Impedance Delay (Note 3)	t7	2		50	ns
\overline{JTRST} Width Low Time	t8	100			ns

Note 1: The timing parameters in this table are guaranteed by design (GBD).

Note 2: Clock can be stopped high or low.

Note 3: Not tested during production test.

Figure 10-9. JTAG Timing Diagram

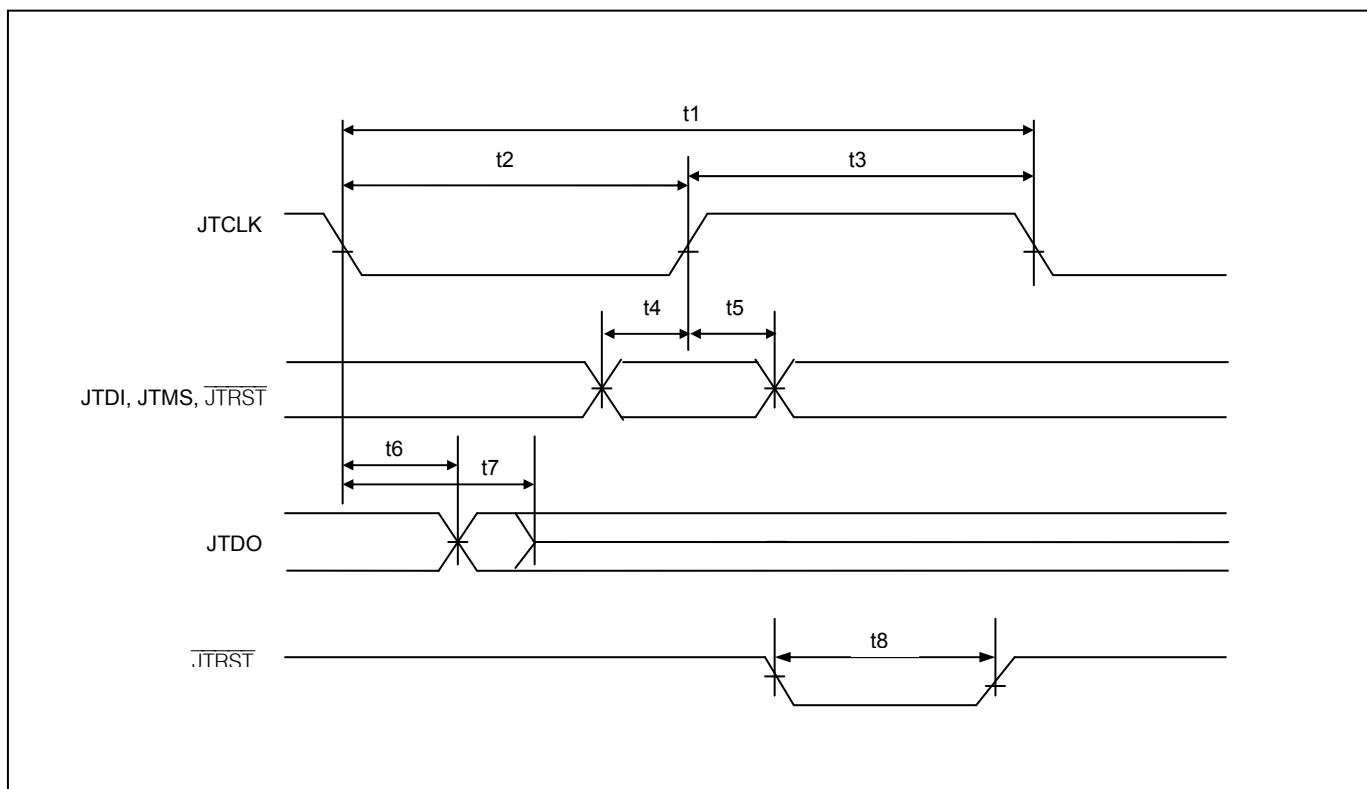

11. PIN ASSIGNMENTS

Table 11-1 lists the DS3100 pin assignments sorted in alphabetical order by pin name. Figure 11-1 and Figure 11-2 show pin assignments arranged by pin number.

Table 11-1. Pin Assignments Sorted by Signal Name

PIN NAME	PIN NUMBER	BUS MODES	SIGNAL TYPE
A[0]	H16	Parallel-Only	High-Speed Digital
A[1]	H15	Parallel-Only	High-Speed Digital
A[2]	G16	Parallel-Only	High-Speed Digital
A[3]	H14	Parallel-Only	High-Speed Digital
A[4]	G15	Parallel-Only	High-Speed Digital
A[5]	F16	Parallel-Only	High-Speed Digital
A[6]	G14	Parallel-Only	High-Speed Digital
A[7]	F15	Parallel-Only	High-Speed Digital
A[8]	E16	Parallel-Only	High-Speed Digital
AD[0]	E15	Parallel-Only	High-Speed Digital
AD[1]	D16	Parallel-Only	High-Speed Digital
AD[2]	C16	Parallel-Only	High-Speed Digital
AD[3]	D15	Parallel-Only	High-Speed Digital
AD[4]	C15	Parallel-Only	High-Speed Digital
AD[5]	E14	Parallel-Only	High-Speed Digital
AD[6]	D14	Parallel-Only	High-Speed Digital
AD[7]	C14	Parallel-Only	High-Speed Digital
ALE	K14	Parallel-Only	High-Speed Digital
AVDD_PLL1	D1	All	Power Supply
AVDD_PLL2	E1	All	Power Supply
AVDD_PLL3	F1	All	Power Supply
AVDD_PLL4	G1	All	Power Supply
AVSS_PLL1	D2	All	Power Supply
AVSS_PLL2	E3	All	Power Supply
AVSS_PLL3	G2	All	Power Supply
AVSS_PLL4	G3	All	Power Supply
CPHA	D14	SPI-Only	Low-Speed Digital
CPOL	C14	SPI-Only	Low-Speed Digital
\overline{CS}	J16	All	High-Speed Digital
\overline{DS}	J14	Parallel-Only	High-Speed Digital
DV _{DD}	H3	All	Power Supply
DV _{SS}	P8	All	Power Supply
GPIO1	E2	All	Low-Speed Digital
GPIO2	F3	All	Low-Speed Digital
GPIO3	H2	All	Low-Speed Digital
GPIO4	J1	All	Low-Speed Digital
\overline{HIZ}	R14	All	Low-Speed Digital
IC1	A10	All	High-Speed Digital
IC10	B12	All	High-Speed Digital
IC11	A13	All	High-Speed Digital
IC12	C12	All	High-Speed Digital

PIN NAME	PIN NUMBER	BUS MODES	SIGNAL TYPE
IC13	B13	All	High-Speed Digital
IC14	A14	All	High-Speed Digital
IC1A	P6	All	Low-Speed Analog
IC2	B10	All	High-Speed Digital
IC2A	P7	All	Low-Speed Analog
IC3	C10	All	High-Speed Digital
IC4	A11	All	High-Speed Digital
IC5NEG	A5	All	High-Speed Analog
IC5POS	B5	All	High-Speed Analog
IC6NEG	A4	All	High-Speed Analog
IC6POS	B4	All	High-Speed Analog
IC7	B11	All	High-Speed Digital
IC8	C11	All	High-Speed Digital
IC9	A12	All	High-Speed Digital
IFSEL[0]	N1	All	Low-Speed Digital
IFSEL[1]	N2	All	Low-Speed Digital
IFSEL[2]	P1	All	Low-Speed Digital
INTREQ	A15	All	Low-Speed Digital
JTCLK	R8	All	Low-Speed Digital
JTDI	R9	All	Low-Speed Digital
JTDO	P9	All	Low-Speed Digital
JTMS	T9	All	Low-Speed Digital
\overline{JTRST}	T8	All	Low-Speed Digital
MASTSLV	R11	All	Low-Speed Digital
MCLK1	F2	All	Low-Speed Digital
MCLK2	T10	All	Low-Speed Digital
N.C.	C13, F14, P12	All	No Connection
OC1	C6	All	High-Speed Digital
OC10	B9	All	Low-Speed Digital
OC11	C9	All	Low-Speed Digital
OC2	A7	All	High-Speed Digital
OC3	B7	All	High-Speed Digital
OC4	C7	All	High-Speed Digital
OC5	A8	All	High-Speed Digital
OC6NEG	A3	All	High-Speed Analog
OC6POS	B3	All	High-Speed Analog
OC7NEG	C1	All	High-Speed Analog
OC7POS	C2	All	High-Speed Analog
OC8NEG	B8	All	Low-Speed Analog
OC8POS	C8	All	Low-Speed Analog
OC9	A9	All	Low-Speed Digital
$\overline{R/W}$	J15	Parallel-Only	High-Speed Digital
RCLK1	K1	All	Low-Speed Digital
RCLK2	R10	All	Low-Speed Digital
\overline{RD}	J14	Parallel-Only	High-Speed Digital
\overline{RDY}	B15	Parallel-Only	High-Speed Digital
REFCLK	H1	All	Low-Speed Digital

PIN NAME	PIN NUMBER	BUS MODES	SIGNAL TYPE
RESREF	T7	All	Low-Speed Analog
ROUT1	K2	All	Low-Speed Digital
ROUT2	P10	All	Low-Speed Digital
RRING1	R5	All	Low-Speed Analog
RRING2	L15	All	Low-Speed Analog
RSER1	J3	All	Low-Speed Digital
RSER2	T11	All	Low-Speed Digital
$\overline{\text{RST}}$	B6	All	Low-Speed Digital
RTIP1	T5	All	Low-Speed Analog
RTIP2	L16	All	Low-Speed Analog
RVDD_P1	T4	All	Power Supply
RVDD_P2	M15	All	Power Supply
RVSS_P1	P5	All	Power Supply
RVSS_P2	M14	All	Power Supply
SCLK	C16	SPI-Only	Low-Speed Digital
SDI	D16	SPI-Only	Low-Speed Digital
SDO	E15	SPI-Only	Low-Speed Digital
SONSDH	M3	All	Low-Speed Digital
SRCSW	M2	All	Low-Speed Digital
SRFAIL	J2	All	Low-Speed Digital
SYNC2K	B14	All	Low-Speed Digital
TCLK1	L2	All	Low-Speed Digital
TCLK2	T12	All	Low-Speed Digital
THZE1	K3	All	Low-Speed Digital
THZE2	T14	All	Low-Speed Digital
TIN1	L1	All	Low-Speed Digital
TIN2	R12	All	Low-Speed Digital
TM1	R13	All	Test, Wire Low
TM2	T15	All	Test, Wire Low
TOUT1	M1	All	Low-Speed Digital
TOUT2	P11	All	Low-Speed Digital
TRING1	R2, T2	All	Low-Speed Analog
TRING2	P15, P16	All	Low-Speed Analog
TSER1	L3	All	Low-Speed Digital
TSER2	T13	All	Low-Speed Digital
TST_RA1	R6	All	Test, Do Not Connect
TST_RA2	L14	All	Test, Do Not Connect
TST_RB1	T6	All	Test, Do Not Connect
TST_RB2	K16	All	Test, Do Not Connect
TST_RC1	R7	All	Test, Do Not Connect
TST_RC2	K15	All	Test, Do Not Connect
TST_TA1	P2	All	Test, Do Not Connect
TST_TA2	R15	All	Test, Do Not Connect
TST_TB1	N3	All	Test, Do Not Connect
TST_TB2	P13	All	Test, Do Not Connect
TST_TC1	P3	All	Test, Do Not Connect
TST_TC2	P14	All	Test, Do Not Connect

PIN NAME	PIN NUMBER	BUS MODES	SIGNAL TYPE
TTIP1	R3, T3	All	Low-Speed Analog
TTIP2	N15, N16	All	Low-Speed Analog
TVDD_P1	R4	All	Power Supply
TVDD_P2	M16	All	Power Supply
TVSS_P1	P4	All	Power Supply
TVSS_P2	N14	All	Power Supply
V _{DD}	D6, D8, D9, D11, E6, E11, F4, F5, F12, F13, H4, H13, J4, J13, L4, L5, L12, L13, M6, M11, N6, N8, N9, N11	All	Power Supply
VDD_ICDIFF	A6	All	Power Supply
VDD_OC6	B2	All	Power Supply
VDD_OC7	C3	All	Power Supply
V _{DDIO}	B1, B16, D7, D10, E7–E10, G4, G5, G12, G13, H5, H12, J5, J12, K4, K5, K12, K13, M7, M8, M9, M10, N7, N10, R1, R16	All	Power Supply
V _{SS}	A1, A16, D4, D5, D12, D13, E4, E5, E12, E13, F6–F11, G6–G11, H6–H11, J6–J11, K6–K11, L6–L11, M4, M5, M12, M13, N4, N5, N12, N13, T1, T16	All	Power Supply
VSS_ICDIFF	C4	All	Power Supply
VSS_OC6	A2	All	Power Supply
VSS_OC7	D3	All	Power Supply
WDT	C5	All	Low-Speed Analog
$\overline{\text{WR}}$	J15	Parallel-Only	High-Speed Digital











Figure 11-1. DS3100 Pin Assignment—Left Half

	1	2	3	4	5	6	7	8
A	V _{SS}	VSS_OC6	OC6NEG	IC6NEG	IC5NEG	VDD_ICDIFF	OC2	OC5
B	V _{DDIO}	VDD_OC6	OC6POS	IC6POS	IC5POS	RST	OC3	OC8NEG
C	OC7NEG	OC7POS	VDD_OC7	VSS_ICDIFF	WDT	OC1	OC4	OC8POS
D	AVDD_PLL1	AVSS_PLL1	VSS_OC7	V _{SS}	V _{SS}	V _{DD}	V _{DDIO}	V _{DD}
E	AVDD_PLL2	GPIO1	AVSS_PLL2	V _{SS}	V _{SS}	V _{DD}	V _{DDIO}	V _{DDIO}
F	AVDD_PLL3	MCLK1	GPIO2	V _{DD}	V _{DD}	V _{SS}	V _{SS}	V _{SS}
G	AVDD_PLL4	AVSS_PLL3	AVSS_PLL4	V _{DDIO}	V _{DDIO}	V _{SS}	V _{SS}	V _{SS}
H	REFCLK	GPIO3	DV _{DD}	V _{DD}	V _{DDIO}	V _{SS}	V _{SS}	V _{SS}
J	GPIO4	SRFAIL	RSER1	V _{DD}	V _{DDIO}	V _{SS}	V _{SS}	V _{SS}
K	RCLK1	ROUT1	THZE1	V _{DDIO}	V _{DDIO}	V _{SS}	V _{SS}	V _{SS}
L	TIN1	TCLK1	TSER1	V _{DD}	V _{DD}	V _{SS}	V _{SS}	V _{SS}
M	TOUT1	SRCSW	SONSDH	V _{SS}	V _{SS}	V _{DD}	V _{DDIO}	V _{DDIO}
N	IFSEL[0]	IFSEL[1]	TST_TB1	V _{SS}	V _{SS}	V _{DD}	V _{DDIO}	V _{DD}
P	IFSEL[2]	TST_TA1	TST_TC1	TVSS_P1	RVSS_P1	IC1A	IC2A	DV _{SS}
R	V _{DDIO}	TRING1	TTIP1	TVDD_P1	RRING1	TST_RA1	TST_RC1	JTCLK
T	V _{SS}	TRING1	TTIP1	RVDD_P1	RTIP1	TST_RB1	RESREF	JTRST
	1	2	3	4	5	6	7	8

- High-Speed Analog
- Low-Speed Analog
- High-Speed Digital
- Low-Speed Digital
- V_{DD} 3.3V
- V_{DD} 1.8V
- Analog V_{DD} 3.3V
- Analog V_{DD} 1.8V
- V_{SS}
- Analog V_{SS}
- N.C. = No Connection. Lead is not connected to anything inside the device.

Figure 11-2. DS3100 Pin Assignment—Right Half

9	10	11	12	13	14	15	16	
OC9	IC1	IC4	IC9	IC11	IC14	INTREQ	VSS	A
OC10	IC2	IC7	IC10	IC13	SYNC2K	\overline{RDY}	VDDIO	B
OC11	IC3	IC8	IC12	N.C.	AD[7]/CPOL	AD[4]	AD[2]/SCLK	C
V _{DD}	V _{DDIO}	V _{DD}	V _{SS}	V _{SS}	AD[6]/CPHA	AD[3]	AD[1] / SDI	D
V _{DDIO}	V _{DDIO}	V _{DD}	V _{SS}	V _{SS}	AD[5]	AD[0]/SDO	A[8]	E
V _{SS}	V _{SS}	V _{SS}	V _{DD}	V _{DD}	N.C.	A[7]	A[5]	F
V _{SS}	V _{SS}	V _{SS}	V _{DDIO}	V _{DDIO}	A[6]	A[4]	A[2]	G
V _{SS}	V _{SS}	V _{SS}	V _{DDIO}	V _{DD}	A[3]	A[1]	A[0]	H
V _{SS}	V _{SS}	V _{SS}	V _{DDIO}	V _{DD}	$\overline{RD}/\overline{DS}$	$\overline{WR}/\overline{RW}$	\overline{CS}	J
V _{SS}	V _{SS}	V _{SS}	V _{DDIO}	V _{DDIO}	\overline{ALE}	TST_RC2	TST_RB2	K
V _{SS}	V _{SS}	V _{SS}	V _{DD}	V _{DD}	TST_RA2	RRING2	RTIP2	L
V _{DDIO}	V _{DDIO}	V _{DD}	V _{SS}	V _{SS}	RVSS_P2	RVDD_P2	TVDD_P2	M
V _{DD}	V _{DDIO}	V _{DD}	V _{SS}	V _{SS}	TVSS_P2	TTIP2	TTIP2	N
JTDO	ROUT2	TOUT2	N.C.	TST_TB2	TST_TC2	TRING2	TRING2	P
JTDI	RCLK2	MASTSLV	TIN2	TM1	HIZ	TST_TA2	V _{DDIO}	R
JTMS	MCLK2	RSER2	TCLK2	TSER2	THZE2	TM2	V _{SS}	T
9	10	11	12	13	14	15	16	

	High-Speed Analog
	Low-Speed Analog
	High-Speed Digital
	Low-Speed Digital
	V _{DD} 3.3V
	V _{DD} 1.8V
	Analog V _{DD} 3.3V
	Analog V _{DD} 1.8V
	V _{SS}
	Analog V _{SS}
	N.C. = No Connection. Lead is not connected to anything inside the device.

12. PACKAGE INFORMATION

For the latest package outline information and land patterns, go to www.maxim-ic.com/packages.

12.1 256-Pin CSBGA (17mm x 17mm)

PACKAGE TYPE	PACKAGE CODE	DOCUMENT NO.
256 CSBGA	—	21-0315

13. THERMAL INFORMATION

Table 13-1. Thermal Properties, Natural Convection

PARAMETER	MIN	TYP	MAX	UNITS
Ambient Temperature (Note 1)	-40		+85	°C
Junction Temperature	-40		+125	°C
Theta-JA (θ_{JA}), Still Air (Note 2)		26.7		°C/W
Theta-JB (θ_{JB}), Still Air		14.0		°C/W
Theta-JC (θ_{JC}), Still Air		11.0		°C/W
Psi-JB		13.5		°C/W
Psi-JT		0.7		°C/W

Note 1: The package is mounted on a four-layer JEDEC standard test board with no airflow and dissipating maximum power.

Note 2: Theta-JA (θ_{JA}) is the junction to ambient thermal resistance, when the package is mounted on a four-layer JEDEC standard test board with no airflow and dissipating maximum power.

14. GLOSSARY

Local Oscillator	The 12.800MHz TCXO, OCXO, or other crystal oscillator connected to the REFCLK pin. The stability of the T0 DPLL in free-run and holdover modes is a function of the stability of this oscillator.
Master Clock	A 204.8MHz clock synthesized from the local oscillator and frequency adjusted by the XOFREQ register setting.
Input Clock	One of the 14 input clocks labeled IC1 to IC14.
Output Clock	One of the 11 output clocks labeled OC1 to OC11.
Selected Reference	The input clock to which the DPLL is currently phase locked.
Valid Clock	An input clock that has no alarms declared in the corresponding ISR register. A clock whose frequency is within the hard limit set in ILIMIT or CLIMIT and that does not have an inactivity alarm.
Invalid Clock	An input clock that has one or more alarms declared in the corresponding ISR register.
External Reference Switching Mode	EXTSW = 1 in MCR10 .

15. ACRONYMS AND ABBREVIATIONS

AIS	Alarm Indication Signal
AMI	Alternate Mark Inversion
APLL	Analog Phase-Locked Loop
BITS	Building Integrated Timing Supply
BPV	Bipolar Violation
DFS	Digital Frequency Synthesis
DPLL	Digital Phase Locked Loop
ESF	Extended Superframe
EXZ	Excessive Zeros
GbE	Gigabit Ethernet
I/O	Input/Output
LOS	Loss of Signal
LVDS	Low-Voltage-Differential Signal
LVPECL	Low-Voltage Positive Emitter-Coupled Logic
MTIE	Maximum Time Interval Error
OCXO	Oven-Controlled Crystal Oscillator
OOF	Out-of-Frame Alignment
PBO	Phase Build-Out
PFD	Phase/Frequency Detector
PLL	Phase-Locked Loop
ppb	Parts per Billion
ppm	Parts per Million
pk-pk	Peak-to-Peak
RMS	Root-Mean-Square
RAI	Remote Alarm Indication
RO	Read-Only
R/W	Read/Write
SDH	Synchronous Digital Hierarchy
SEC	SDH Equipment Clock
SETS	Synchronous Equipment Timing Source
SF	Superframe
SONET	Synchronous Optical Network
SSM	Synchronization Status Message
SSU	Synchronization Supply Unit
STM	synchronous Transport Module
TDEV	Time Deviation
TCXO	Temperature-Compensated Crystal Oscillator
UI	Unit Interval
UI _{p-p}	Unit Interval, Peak to Peak

16. TRADEMARK ACKNOWLEDGEMENTS

ACCUNET is a registered trademark of AT&T.

SPI is a trademark of Motorola, Inc.

Telcordia is a registered trademark of Telcordia Technologies.

17. DATA SHEET REVISION HISTORY

REVISION NUMBER	REVISION DATE	DESCRIPTION	PAGES CHANGED
0	062106	Initial release.	—
1	092106	Changed all occurrences of 0.5MHz (megahertz) to 0.5mHz (milliHertz).	1, 12, 24, 37, 38, 42
		In Figure 3-1 , corrected arrow directions between backplane and timing cards.	9
		In second-to-last paragraph of Section 7.5.2, changed LBxS = 1 to LBxS = 10.	30
		In Figure 7-7 , edited figure so the TSYNC label does not cover up a portion of the TCLK wire.	58
		In Table 8-2 , updated the color coding.	82
		DLIMIT2 register description changed to end in “2” not “1.”	111
		In Table 8-3 , BTCR1 (27h) bit 3 changed to “1”; BLCR1 address changed from 18h to 10h; BLCR2 bit 3 changed to “0”; BLCR3 bit 7 changed to “0”; BRIIR bits marked as read-only (i.e., underlined).	147
		Changed BRCCR3 bit 5 to RSIGM; added description.	166
		BRCCR5 register bit 0 name changed from “—” to “1.”	167
		BTCR4 register description changed to end in “4” not “1.”	171
2	121806	Added GBD comments (Note 1) to AC timing characteristics in Section 10.	203, 206, 208, 209, 210, 213, 214
3	013007	In Table 6-10 deleted N6 from the V _{SS} pin description (N6 is V _{DD})	22
4	030807	Updated spec name from G.pactiming to G.8261.	1
		In Table 6-4 , edited the TTIP1/TRING1 and TTIP2/TRING2 pin descriptions to indicate that identical TTIP pins should be externally wired together, and identical TRING pins should be externally wired together.	18
		Edited Section 7.4 to indicate minimum high time or low time is 3ns or 30% of clock period, whichever is smaller.	26
		In Table 7-2 added indications that IC5 and IC6 can be CMOS/TTL inputs.	27
		Added note at the end of Section 7.7.1.7 to indicate that mini-holdover follows the manual holdover setting.	36
		Added hyperlink to Maxim app note HFAN-1.0 in Section 7.8.1.	45
		In the 125MHz row of Table 7-13 , corrected a typo by changing “OC4 and OC5 only” to “OC5 only”.	53
		Updated Figure 7-8 to correct a wiring mistake regarding the input to the “x16 Multiplier PLL”. (Page 62) Updated Figure 7-10 to show the two TTIP pins connected together and the two TRING pins connected together.	59
		Added Note 2 to Table 10-4 .	204
		Added Note 3 to Table 10-5 .	205
		Updated Figure 10-3 and Table 10-7 and accompanying text to show new recommended external components.	206
		Updated Table 10-8 to clarify minimum high time and low time (and therefore duty cycle) for input clocks.	207

REVISION NUMBER	REVISION DATE	DESCRIPTION	PAGES CHANGED
5	032907	In the Feature bullets, changed “G.812 Types I and III” to “G.812 Types I, III and IV”.	1
		Deleted reference to IEEE 1596.3 standard from Table 1-1 .	7
		Updated Figure 3-1 to show backplane traces going between timing cards.	9
		Edited Section 7.10.1 to improve clarity.	59
		(Pages) Edited Sections 7.10.5.1 , 7.10.5.2 , 7.10.6.1 , and 7.10.6.2 to clarify when the BRCR and BTCR registers should be written during the receive framer and transmit formatter initialization processes.	68–71
		In Section 7.10.7.2 , added text to describe the additional writes that must be done to optimize the BITS LIU transmitter when entering or leaving 2048kHz mode.	72
		Rewrote Section 7.15 to refer readers to the web or Telecom Support for the latest initialization scripts.	80
		In the BMCR bits 5 and 4 description, replaced “Values not listed are undefined.” with “See Section 7.10.7.2 for write sequences that must be done when entering or leaving the 2048 kHz mode.”	149
6	060607	BLCR2 , BLCR3 , BRCR5 , BTCR1 : For each bit that should always be set to zero or set to one, added a bit description to remind the reader that these bits must be set to zero/one.	155, 156, 167, 168
		In register BCCR5 , updated the description of bits 5 and 4 to indicate that the device squelches and increments the activity monitor on zeros rather than invalidating.	154
		Edited Section 7.7.6 and the DLIMIT1 and DLIMIT3 :FLLLOL descriptions to indicate that the T4 DPLL’s hard limit is fixed at ± 80 ppm and is not controlled by the HARDLIM field.	39, 111, 118
		In Section 7.7.2 , corrected a typo to say the T4 DPLL only operates in revertive switching mode rather than “does not have revertive switching mode.”	36
		Edited the OFREQ1 through OFREQ7 fields in the OCR registers to indicate that if the T4 DPLL is configured for 62.5MHz, then OFREQ = 1100 specifies T4 APLL frequency divided by 10 to give an output frequency of 25MHz.	123
		Added a 25MHz row to Table 7-13 .	50
		In Table 10-2 , changed I_{DD18} (Note 2) to 129mA typ, 152mA max; changed I_{DD18} (Note 3) to 130mA typ, 154mA max; changed I_{DD33} (Note 2) to 36mA typ, 53mA max; changed I_{DD33} (Note 3) to 124mA typ, 145mA max. The changes are necessary to account for the power consumption of the differential I/O, which were not functional in rev A1 parts. Also changed I_{DDR1} from 29mA typ to 35mA typ.	203
		In Table 10-3 changed VDD to VDDIO in the VOH max spec and in Note 1.	204
		In Table 10-4 , changed V_{OHLVDS} to 1.45V typ, 1.65V max; added V_{OLLVDS} 1.1V typ; changed V_{OSLVDS} to 1.08V min, 1.28V typ, 1.45V max.	204
		In Table 10-5 , deleted specs I_{IHPECL} and I_{ILPECL} specs and in Note 2 changed VDD to VDDIO.	205
		In Table 10-6 in the V_{IHAMI} spec, changed max from VDD+0.3 to VDDIO+0.3 and deleted the I_{AMIOU} , V_{OHAMI} , and V_{OLAMI} specs because the specs in Table 7-22 and Figure 7-17 are sufficient to govern output signal performance for OC8.	206
		In Table 7-13 , updated many of the typical rms and peak-to-peak jitter numbers to match rev A2 device performance.	50
In Table 7-9 , corrected typo, 68.376 to 68.736.	48		

REVISION NUMBER	REVISION DATE	DESCRIPTION	PAGES CHANGED
7	012108	Added pin N5 to the VSS row in Table 6-10 .	22
		Edited Section 7.13 to emphasize the need for the $\overline{\text{RST}}$ pin to be asserted once after power-up and to describe the need to wait at least 100 μs after reset is deasserted before initializing the device.	79
		In Section 8.5 , changed "080h + 16h = 96h" to "080h + 1Ah = 9Ah." In Table 8-3 , changed BTCR1 bit 3 from "1" to "—".	147
		In the BLCR4 description, changed the TPD and RPD bit descriptions to show they are set to 0 rather than 1.	157
		In the BTMMR description for the TID bit, changed "receiver" to "transmitter."	163
		In the BTCR1 , changed bit 3 from "1" to "—".	168
		In BTSR1 and BTIER1 , corrected typo for bit 1 and changed "—" to "LOTCC".	181
8	062508	In registers BRSiAF , BRSiNAF , BRRAI , BRSa4 through BRSa8 , BTSiAF , BTSiNAF , BTRAI , and BTSa4 through BTSa8 , corrected bit-ordering typo so that bit 7 of the register contains the "F15" or "F14" bit while bit 0 of the register contains the "F1" or "F0" bit.	185–188, 193–196
		In Table 10-14 , changed t_{CYC} to 166ns min, t_{CLKH} to 80ns min, and t_{CLKL} to 80ns min to match f_{BUS} max of 6MHz.	213
9	5/09	<p>On page 1 and various locations in the document, added mention of Stratum 2 compliance, expanded G.812 compliance to Types I – IV, and added G.8262 EEC compliance.</p> <p>In Table 1-1, added G.8262.</p> <p>In Table 6-1, indicated that differential inputs IC5 and IC6 could be configured as singled-ended CMOS/TTL and how to do it.</p> <p>In Table 7-1, deleted the initial offset row since it is not an oscillator requirement.</p> <p>Next to Table 8-1, added note indicating systems must be able to access entire address range 0-1FFh.</p>	1, 7, 15, 25, 81