

### FEATURES

- Compact two-piece, all-metal receptacle for F5 MicroCan™
- Accepts two-thirds of the MicroCan (one-third of MicroCan will extend out)
- Allows reading iButtons with either momentary or dwelled contact
- Outer ring will hold MicroCan for dwelled contact
- Two options for data contact: cantilever (DS9100B) or coiled spring (DS9100C)
- >10000 insertion/withdrawal cycles with no performance degradation
- Redundancy of contacts and high contact force ensure reliability
- Probe withstands high temperatures required for PCB solder reflow operations
- Material is stainless steel with selective tin-lead plating for optimal solderability to printed circuit board
- Cleaning fluids drain freely for quick clean up

### ORDERING INFORMATION

DS9100A	Outer Contact (Ground)
DS9100B	Center Contact Cantilever (Data)
DS9100C	Center Contact Coiled Spring (Data)

### DS9100A WITH DS9100B

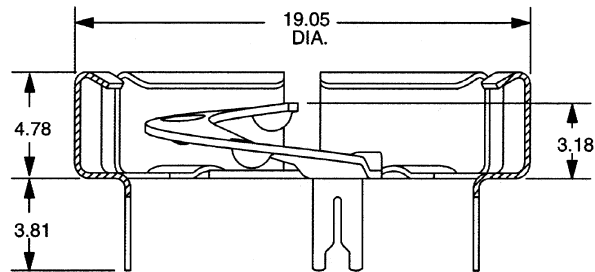
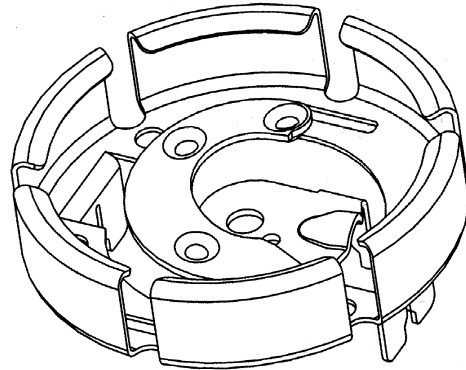

Dimensions are in millimeters

### DS9100C WITH CORRECT ORIENTATION TO SOLDER PAD

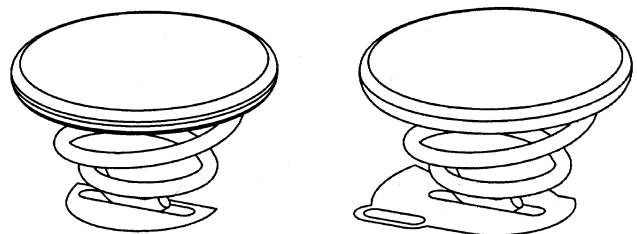

### DESCRIPTION

The DS9100 Touch and Hold Probe Stampings' function is similar to the DS9098 iButton Retainer. An F5 MicroCan will fit completely into the DS9098, but the flange and about one-third of the can will extend out if pressed into the DS9100. As a probe, the DS9100A together with the coiled spring DS9100C allows reading iButtons on contact. With additional pressure, the stiff springs of the DS9100A's outer ring will deflect and grip the MicroCan sufficiently to provide a continuous contact to both the can rim (ground) and the can lid (data). If reading on contact is not required, the cantilever type center contact DS9100B can be used rather than the DS9100C.

# PRINTED CIRCUIT BOARD LAYOUTS

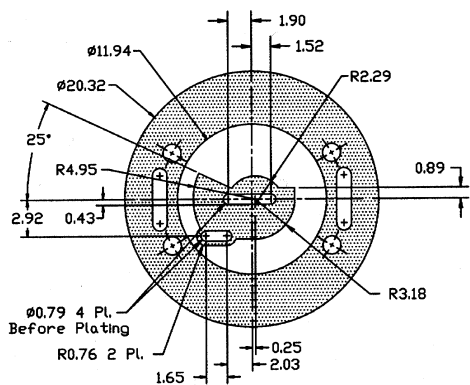

SIDE A

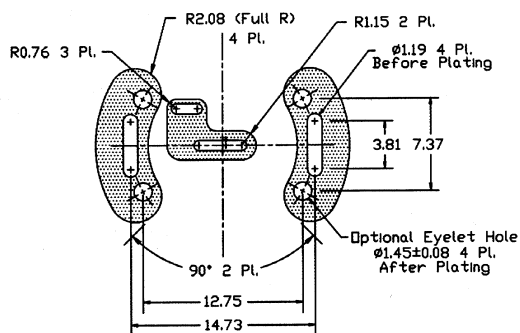

SIDE B

Compatible PCB layout.

Good for either center part DS9100B or DS9100C

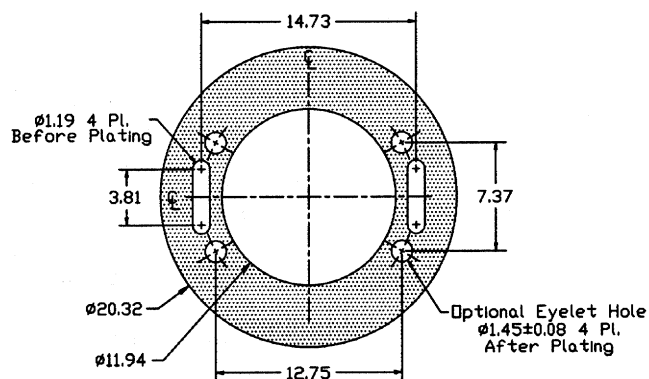

SIDE A

Additional dimensions for ground contact.

CENTER-DATA      OUTER RING-GROUND  
 COPPER CLADDING > 0.3 kg/m<sup>2</sup> or > 34 μm  
 (> 1 oz/sq. ft)

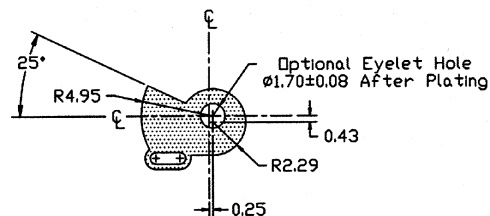

Side A

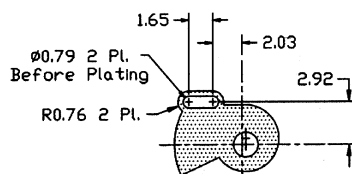

Side B

Center piece optimized for cantilever DS9100B

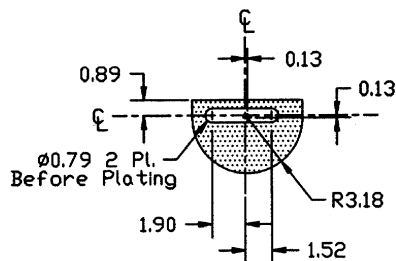

Side A

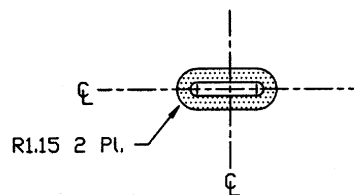

SIDE B

Center piece optimized for coiled spring DS9100C

Dimensions are in millimeters.

The DS9100 stampings are mounted on Side A of the printed circuit board.