



MAX1512 Evaluation Kit

General Description

The MAX1512 evaluation kit (EV kit) is an assembled and tested printed-circuit board (PCB) that demonstrates and programs the MAX1512 LCD display. A rotary optical encoder (U8) provides simple hand adjustment of the MAX1512 and a pushbutton switch (SW1) initiates an EEPROM programming sequence, which locks the current MAX1512 code into EEPROM.

Features

- ◆ 128-Step Adjustable Sink Current Output
- ◆ Resistor-Adjustable Full-Scale Range
- ◆ Output Guaranteed Monotonic Over Operating Range
- ◆ 2.6V to 3.6V Logic Supply Voltage Operating Range (V_{DD})
- ◆ 4.5V to 20V Analog Supply Voltage Range (V_{AVDD})
- ◆ 3.3V Programming Circuit Supply Voltage (V_{CC})
- ◆ Fully Assembled and Tested

Ordering Information

PART	TYPE
MAX1512EVKIT	EV Kit

Component List

DESIGNATION	QTY	DESCRIPTION
C1, C16, C20	3	1 μ F \pm 10%, 25V X5R ceramic capacitors (1206) Any case size okay
C2	1	10pF \pm 5%, 50V C0G ceramic capacitor (0603) TDK C1608C0G1H100J
C3, C11	2	4.7 μ F \pm 10%, 25V X5R ceramic capacitors (1210) Taiyo Yuden TMK325BJ475MN
C4	1	10 μ F \pm 10%, 16V X5R ceramic capacitor (1210) Taiyo Yuden EMK325F106ZF
C8, C9, C19	3	1 μ F \pm 10%, 10V X5R ceramic capacitors (0603) TDK C1608X5R1A105K
C10, C18	2	0.01 μ F \pm 10%, 50V X7R ceramic capacitors (0603) TDK C1608X7R1H103K
C12	1	0.047 μ F \pm 10%, 16V X7R ceramic capacitor (0603) TDK C1608X7R1E473K

DESIGNATION	QTY	DESCRIPTION
C13	0	Not installed, ceramic capacitor (0603)
C14, C15, C17	3	0.1 μ F \pm 10%, 16V X5R ceramic capacitors (0603) TDK C1608X7R1C104K
C21	1	0.1 μ F \pm 10%, 25V X5R ceramic capacitor (0805) Taiyo Yuden UMK212BJ104MG
D1	1	30V, 500mA Schottky diode (SOD-A23) Nihon EP05Q03L
JU1, JU2	2	2-pin headers
L1	1	10 μ H, 700mA inductor Sumida CR32-100
LED1	1	LED Panasonic LN21RPHC Digi-Key P300-ND
N1	1	FET Fairchild Semiconductor FDN337N
R1	1	1.96M Ω \pm 1% resistor (0805)
R2	1	160k Ω \pm 1% resistor (0805)
R3	1	10k Ω \pm 5% resistor (0805)

MAX1512 Evaluation Kit

Component List (continued)

DESIGNATION	QTY	DESCRIPTION
R4, R13	2	100k Ω \pm 5% resistors (0805)
R5	1	500 Ω \pm 5% resistor (0805)
R6	1	7.5k Ω \pm 0.1% resistor (0805)
R7	1	100k Ω \pm 0.1% resistor (0805)
R8	1	18k Ω \pm 0.1% resistor (0805)
R9	1	200k Ω \pm 1% resistor (0805)
R10	1	245k Ω \pm 1% resistor (0805)
R11	1	1k Ω \pm 5% resistor (0805)
R12	1	24.9k Ω \pm 1% resistor (0805)
SW1	1	Programming pushbutton switch OMRON B3F-1000 Digi-Key SW400-ND
U1	1	Maxim boost converter MAX1605EUT (6-pin SOT23)
U2	1	Maxim linear regulator MAX1659ESA (8-pin SO)

DESIGNATION	QTY	DESCRIPTION
U4	1	Microcontroller (μ C) Digi-Key PIC12C509A-04/SN or PIC12C509A-04E/SN or PIC12C509A-04I/SN
U5	1	Maxim low-power, 13-bit, voltage- output digital-to-analog converter (DAC) MAX5132AEEE (16-pin QSOP)
U6	1	Maxim \pm 15V chopper stabilized operational amplifier (op amp) MAX420EPA (8-pin DIP)
U7	1	Maxim EEPROM-programmable TFT VCOM calibrator MAX1512ETA (8-pin TDFN, 3mm x 3mm)
U8	1	Rotary optical encoder Grayhill 63R128
—	1	PCB: MAX1512 Evaluation Kit

Component Suppliers

SUPPLIER	PHONE	WEBSITE
Digi-Key Corp.	800-344-4539	www.digikey.com
Fairchild Semiconductor	888-522-5372	www.fairchildsemi.com
Nihon Inter Electronic Corp.	847-843-7500	www.niec.co.jp
Panasonic Corp.	714-373-7366	www.panasonic.com
Sumida Corp.	847-545-6700	www.sumida.com
Taiyo Yuden	800-348-2496	www.t-yuden.com
TDK Corp.	847-803-6100	www.component.tdk.com

Note: Indicate that you are using the MAX1512 when contacting these component suppliers.

MAX1512 Evaluation Kit

Evaluates: MAX1512

Quick Start

Recommended Equipment

Before beginning, the following equipment is needed:

- 5V power supply
- Scope probe
- Voltmeter

Procedure

The MAX1512 EV kit is a fully assembled and tested surface-mount board. Follow the steps below to verify board operation. **Caution: Do not turn on the power supply until all connections are completed.**

- 1) Apply 2.6V to 3.6V to V_{DD} .
- 2) Verify that a shunt is installed on JU2. This enables the programming interface.
- 3) Apply 3.3V to V_{CC} to power the programming circuit.
- 4) Verify that the LED is on. This indicates that the MAX1512's code has not been changed since V_{DD} has been powered up.
- 5) Rotate the knob greater than 10 degrees in either direction.
- 6) Verify that the LED is off. This indicates that there has been some change in the output.
- 7) Connect a voltmeter to OUT. OUT should move up/down in increments of $V_{AVDD} \times 0.001727$ as the knob is rotated 9.2 degrees clockwise/counterclockwise.
- 8) Connect a scope probe to CTL. Up and down "tics" are generated as the knob is rotated clockwise/counterclockwise.
- 9) Measure OUT using the voltmeter.
- 10) Press the programming pushbutton switch (SW1).
- 11) Verify that the LED is on. This indicates that the part has been programmed.
- 12) Remove all power. Wait 5s for capacitors to discharge.
- 13) Reapply power (V_{CC} , V_{DD} , and V_{AVDD}).
- 14) Verify that the measurement for OUT was properly restored to the value measured in step 9.
- 15) The output range/resolution may be adjusted by changing resistors R9, R10, and R12, as described in the MAX1512 IC data sheet. The CTL output may be connected to the actual application circuit and the EV kit may be used as a complete solution for programming the IC.

Detailed Description

The MAX1512 evaluation kit (EV kit) is a fully assembled and tested surface-mount PCB used for evaluating and programming the MAX1512. The MAX1512 EV kit includes a microcontroller, optical encoder, and DAC for adjusting and programming the MAX1512. The EV kit is suitable for factory operation "as is" and provides a fast and accurate method for manually calibrating LCD panels. The board is built in two halves. The left side contains the microcontroller (U4), optical encoder (U8), DAC (U5), op amp (U6), and power supply; the right side contains the MAX1512 (U7) and its components. Only two wires (GND and CTL) join the two sides together. Provide a 2.4V to 5.5V supply at V_{CC} to adjust or program the MAX1512. Provide a 2.6V to 3.6V supply at V_{DD} to power the MAX1512. The MAX1512's output is set with respect to V_{AVDD} , which may be between 4.5V and 20V.

The 256-position optical encoder allows fine, linear, and monotonic control of the MAX1512 output setting. Turn the optical encoder counterclockwise to increase the output voltage of the MAX1512. Turn the optical encoder clockwise to decrease the output voltage of the MAX1512. If the knob has not been turned since the part was last programmed, the LED will remain on. Any adjustment will turn the LED off. The LED will flicker as the knob is turned. In order to program the part, simply press the programming pushbutton switch (SW1) on the EV kit. The microcontroller will generate the appropriate EEPROM burn waveform and the LED will turn on, indicating that the burn cycle is complete.

Setting V_{OUT} Range

The output adjustment range of the MAX1512 is set by resistors R9, R10, and R12, and is ratiometric with respect to V_{AVDD} . Choose R9 and R10 according to the maximum desired output voltage. Choose R12 to set the minimum desired output voltage and the resolution. Calculate R9 and R10 according to the following equation:

$$\frac{R9}{R10} \approx \frac{V_{AVDD}}{V_{MAXIMUM}} - 1$$

Calculate R12 according to the following equation:

$$R12 \approx 20 \times \frac{V_{MAXIMUM} - V_{MINIMUM}}{V_{MAXIMUM}}$$

The corresponding resolution is:

$$\text{Resolution} \approx \frac{V_{MAXIMUM} - V_{MINIMUM}}{20}$$

MAX1512 Evaluation Kit

Programming Interface

The MAX1512 EV kit contains all the hardware necessary to adjust/program the MAX1512. A microcontroller (U4) communicates to the MAX5132 13-bit DAC to produce the programming waveform shown in Figure 1. This programming waveform is initiated either by pressing a pushbutton switch (SW1) or by pulling PROGRAM high through external hardware. In addition, the microcontroller decodes the quadrature encoded rotary encoder. A quadrature signal may be generated through software to force the MAX1512 EV kit to generate the required up/down "tics" at CTL.

Since the left side of the board (user interface) is fully independent from the right side of the board (MAX1512 circuit), V_{CC} may be powered down. If V_{CC} is removed, the MAX420 op amp will pull CTL low. If V_{CC} is removed and then reapplied, the output will be decremented by one LSB. For this reason it may be appropriate to cycle power-on V_{DD} after V_{CC} is applied. Additionally, the MAX1512 control interface may be disabled by connecting a shunt across JU2.

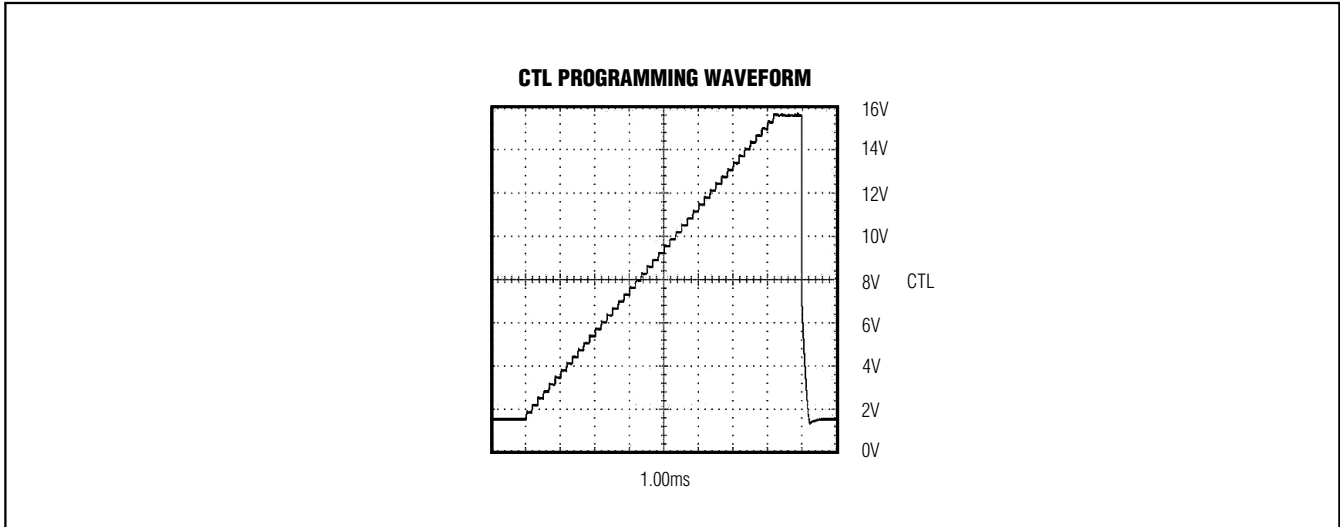

Figure 1. CTL Programming Waveform

MAX1512 Evaluation Kit

Evaluates: MAX1512

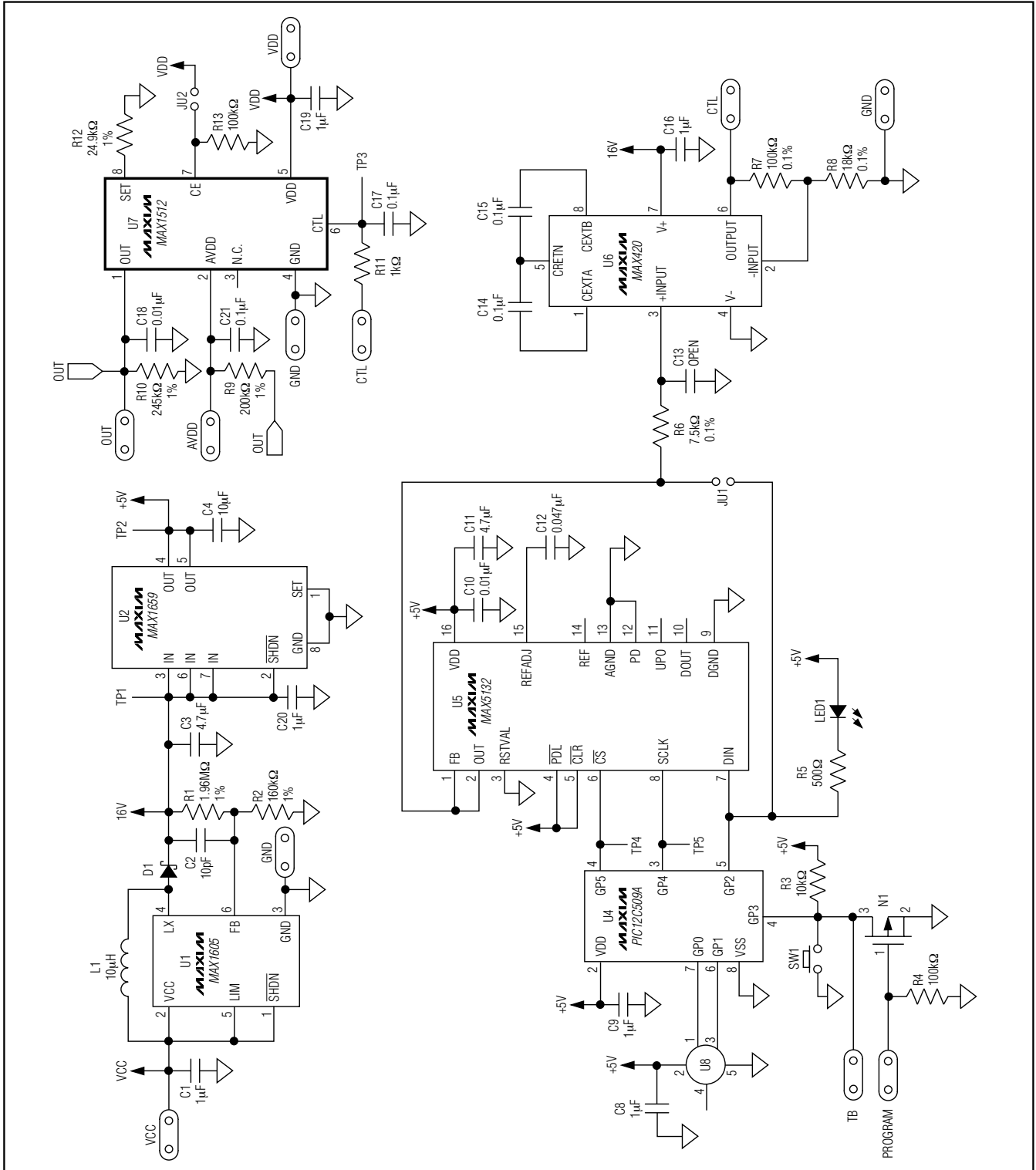

Figure 2. MAX1512 EV Kit Schematic

MAX1512 Evaluation Kit

Evaluates: MAX1512

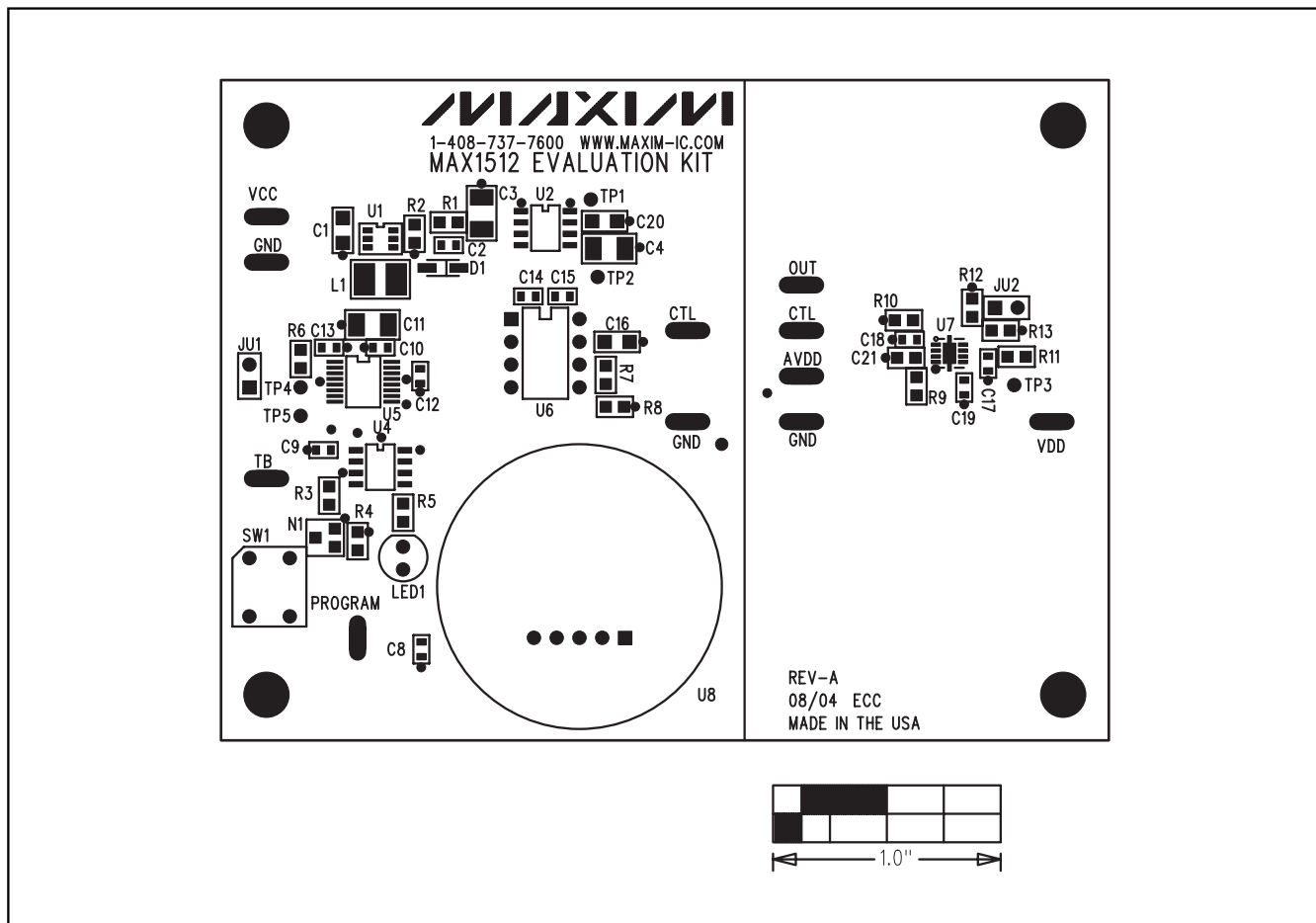

Figure 3. MAX1512 EV Kit Component Placement Guide—Component Side

MAX1512 Evaluation Kit

Evaluates: MAX1512

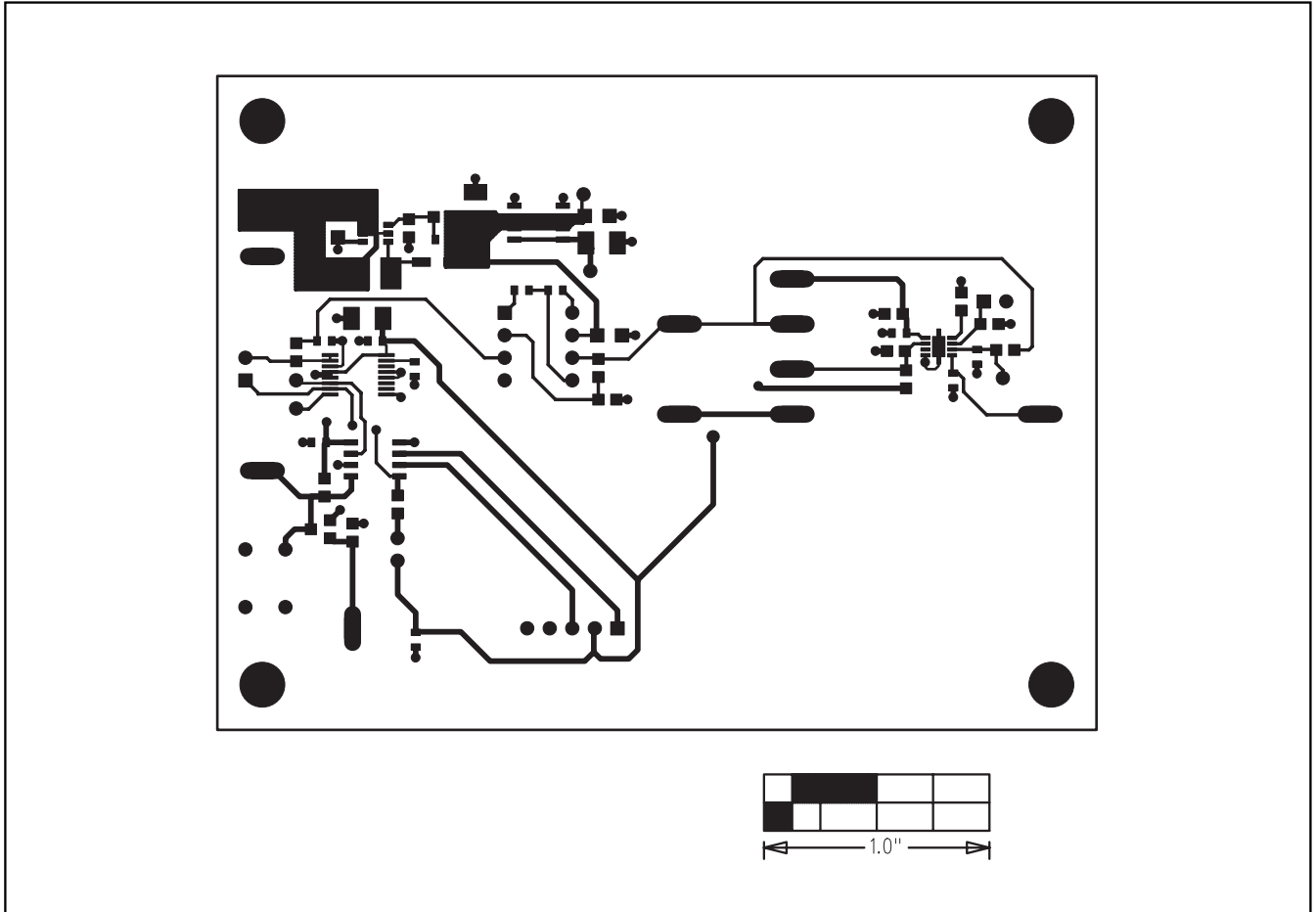

Figure 4. MAX1512 EV Kit PCB Layout—Component Side

MAX1512 Evaluation Kit

Evaluates: MAX1512

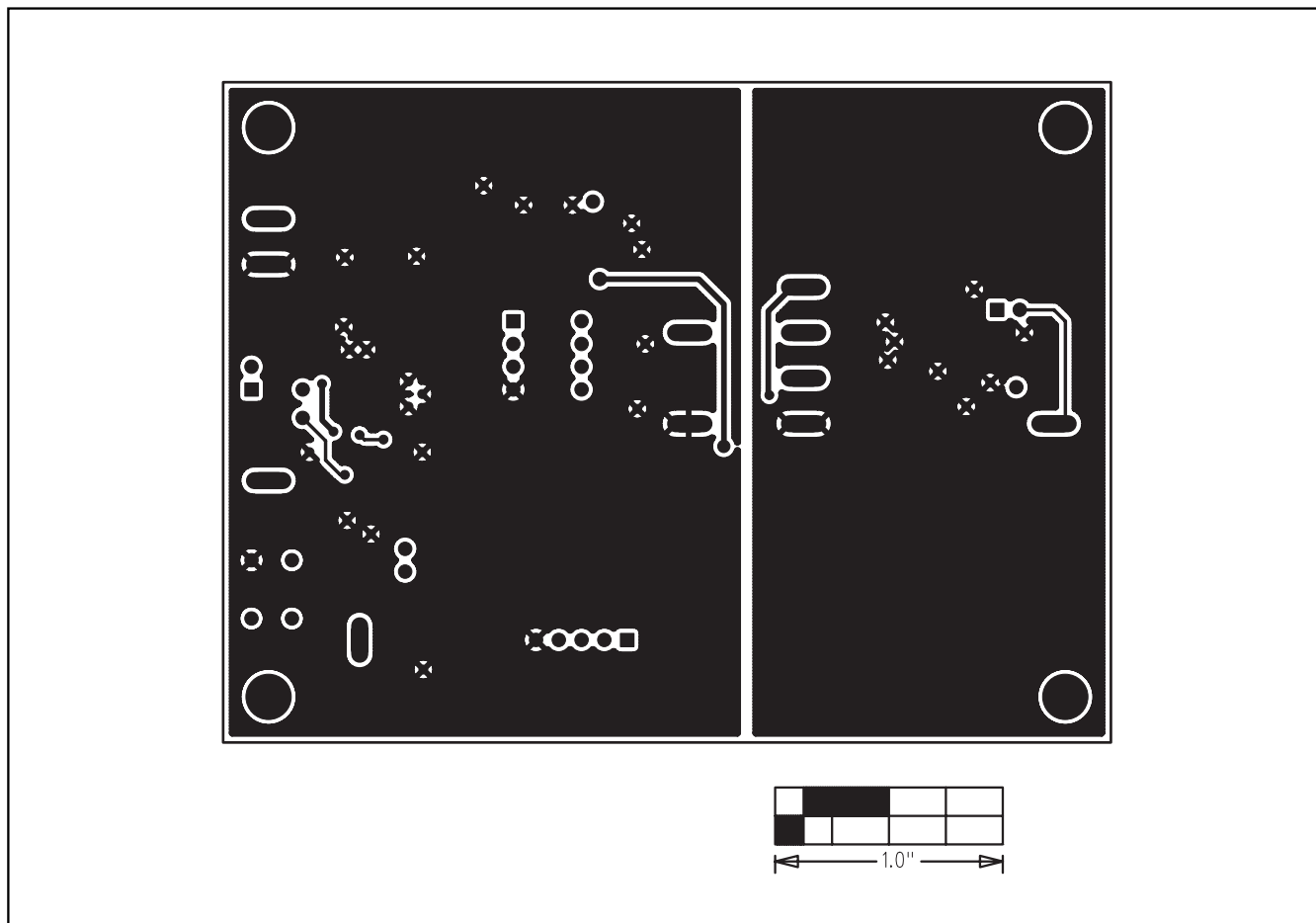

Figure 5. MAX1512 EV Kit PCB Layout—Solder Side

Maxim cannot assume responsibility for use of any circuitry other than circuitry entirely embodied in a Maxim product. No circuit patent licenses are implied. Maxim reserves the right to change the circuitry and specifications without notice at any time.

8 **Maxim Integrated Products, 120 San Gabriel Drive, Sunnyvale, CA 94086 408-737-7600**

© 2007 Maxim Integrated Products

MAXIM is a registered trademark of Maxim Integrated Products, Inc.

www.BDTIC.com/maxim