

MAXIM

MAX3524 Evaluation Kit

Evaluates: MAX3524

General Description

The MAX3524 evaluation kit (EV kit) enables RF evaluation of the MAX3524 low-noise, high-linearity broadband amplifier and the closed-loop DC gain of the operational amplifier (op amp) without any additional support circuitry. The MAX3524 EV kit is assembled with the MAX3524 and incorporates input and output components that facilitate testing from 44MHz to 880MHz. The EV kit provides 50Ω SMA connectors for the RF input and output signals. Figure 1 shows the MAX3524 EV kit schematic diagram. For more information about the MAX3524, consult the MAX3524 data sheet.

Features

- ◆ Easy Evaluation of the MAX3524
- ◆ +4.75V to +5.25V Single-Supply Operation
- ◆ RF Input and Output Matched to 50Ω
- ◆ SMA Connectors at RF Signal Ports
- ◆ 50Ω to 75Ω Minimum Loss Pad at the Input

Ordering Information

PART	TEMP RANGE	IC-PACKAGE
MAX3524EVKIT	-40°C to +85°C	10 μMAX-EP

Component List

DESIGNATION	QTY	DESCRIPTION
C1	1	47pF ±5% ceramic capacitor (0603) Murata GRM39COG470J050A
C2, C14		Not installed
C3, C19, C20	3	10μF, 16V ±10% tantalum capacitors AVX TAJC106K016
C10, C11, C12, C13, C15, C16	6	0.1μF ±10% ceramic capacitors (0603) Murata GRM39X7R104K016A
D1, D2	2	Diodes Central Semiconductor CMD5H-3 (SOD323)
J1, J7	2	SMA edge mount connectors EF Johnson 142-0701-801
J2, J3, J4, J5, J6, J9, TP1, TP4, TP5	9	Test points
L5	1	680nH inductor Coilcraft 1206CS-681XJBC
R1	1	43.2Ω ±1% resistor (0603) Kamaya RMC16-43R2FT

DESIGNATION	QTY	DESCRIPTION
R2	1	86.6Ω ±1% resistor (0603) Kamaya RMC16-86R6FT
R3, R7		Not installed
R4	1	49.9kΩ ±1% resistor (0603) Kamaya RMC16-4992FT
R5, R6, R10, R11	4	3kΩ ±5% resistors (0603) Kamaya RMC16-302JB
R9	1	100Ω ±5% resistor (0603) Kamaya RMC16-101JB
R12	1	6.19Ω ±1% resistor (0603) RMC16-6R20FT
T2	1	Balun transformer M/A COM ETC1-1-13
U1	1	MAX3524EUB, 10-pin μMAX-EP NOTE: U1 has an exposed paddle requiring soldering to the circuit board to insure proper function of the part.
None	1	MAX3524 EV kit data sheet
None	1	MAX3524 Rev C EV kit circuit board

MAX3524 Evaluation Kit

Quick Start

The MAX3524 EV kit is fully assembled and factory tested. Follow the instructions in the *Connections and Setup* section for proper device evaluation.

Recommended Test Equipment

Two Power Supplies or a Dual Voltage Power Supply	One supply capable of providing at least 200mA at +4.75V to +5.25V to bias the RF amplifier and the op amp. The other supply to test the closed-loop gain of the op amp.
Network Analyzer	HP8753D or equivalent for measuring RF power gain.
Cables (50Ω)	Two 50Ω cables with SMA connectors.
Voltmeter	To measure op amp output.
Ammeter (optional)	For measuring supply current.
Noise Figure Meter (optional)	HP8970B or equivalent for measuring the noise figure of the RF amplifier.

Connections and Setup

This section provides a step-by-step guide to setting up the MAX3524 EV kit and testing the broadband LNA. **Do not apply DC power or RF signals until all connections are made.**

Broadband Low Noise Amplifier

Note: The input to the LNA is preceded by a minimum loss pad that transforms the source impedance from 50Ω to 75Ω. The insertion loss of this is pad is 5.7dB.

- 1) Connect a DC supply preset to +5V (through an ammeter, if desired) to the EV kit's VCC (J9) and GND (J6) terminals. Do not turn on the supply.
- 2) Perform a full two-port calibration on a network analyzer at a power level of -25dBm. Refer to the network analyzer's operating manual for detailed instructions.
- 3) Connect port 1 and port 2 of a network analyzer to the LNAIN SMA connector (J1) and LNAOUT SMA connector (J7), respectively.
- 4) Turn on the DC supply. The supply current should read approximately 85mA (if using an ammeter). Measure DC voltage between J9 and J6 to ensure 5V

operation. Adjust power supply output as needed.

- 5) The network analyzer display should indicate a typical gain of 4.25dB at 44MHz. The MAX3524 EV kit utilizes a 50Ω to 75Ω pad. The insertion loss of this pad is approximately 5.7dB. The actual gain of the MAX3524 when driven by a 75Ω source is:

Measured Gain + 5.72dB

(The MAX3524 data sheet specifies voltage gain with a 3kΩ load. This typically results in a voltage gain of 15dB.)

Checking Noise Figure

Noise figure measurements are sensitive to board and lab setup losses and parasitics. There are many techniques and precautions for measuring a low-noise figure. Detailed explanation of these items goes beyond the scope of this document. For more information on how to perform this level of noise-figure measurement, refer to the noise-figure meter operating manual, as well as to Hewlett Packard application note #57-2, *Noise Figure Measurement Accuracy*. The EV kit board consists of a 50Ω to 75Ω pad at the input of the amplifier, which introduces a loss of 5.72dB. To obtain the correct noise figure of the MAX3524, subtract 5.72dB from the measured noise figure.

Closed-Loop Gain of Op Amp

- 1) Connect a DC supply preset to +5V (through an ammeter, if desired) to the EV kit's VCC (J9) and GND (J6) terminals. Do not turn on the supply.
- 2) Connect a second DC supply preset to +2V to the EV kit's terminal J2 and GND (J6) terminals.
- 3) Turn on the DC supplies.
- 4) Measure the output of the op amp at TP4 (Test Point 4) using the voltmeter. The voltmeter should display approximately +2V, taking into account the input resistor voltage-divider (1/2 and closed-loop gain +2) of the op amp.

PC Board Layout Considerations

The MAX3524 EV kit can serve as a board layout guide. Keep PC board trace lengths as short as possible to minimize parasitics. Long PC board traces at the input and output of the MAX3524 can degrade gain flatness. Keep decoupling capacitors as close to the device as possible, with a low inductance connection to the ground plane.

MAX3524 Evaluation Kit

Evaluates: MAX3524

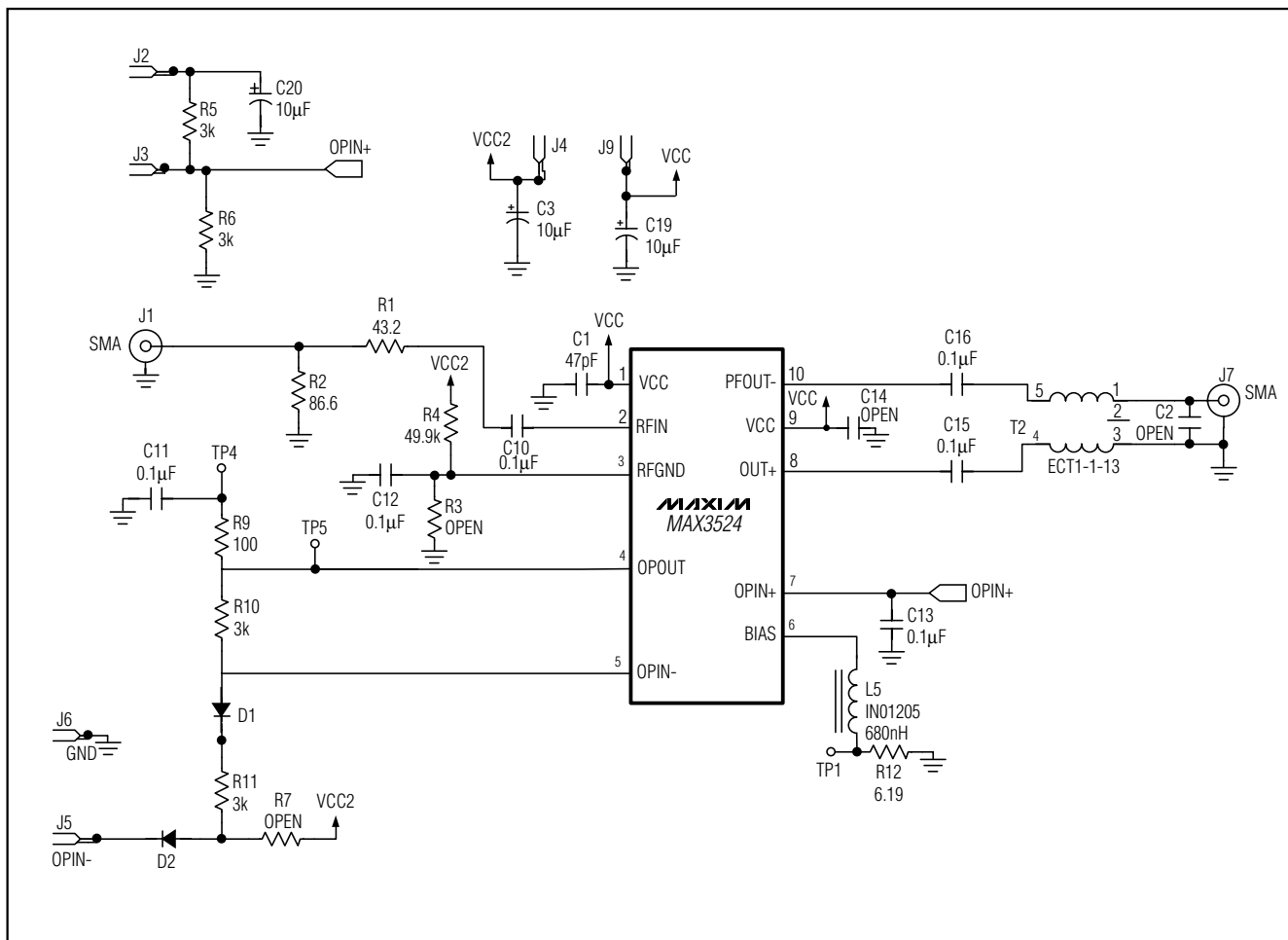

Figure 1. MAX3524 EV Kit Schematic

MAX3524 Evaluation Kit

Component Suppliers

SUPPLIER	PHONE	FAX	WEB ADDRESS
AVX	803-946-0690	803-626-3123	www.avxcorp.com
Coilcraft	847-639-6400	847-639-1469	www.coilcraft.com
EF Johnson	402-474-4800	402-474-4858	www.efjohnson.com
Kamaya	219-489-1533	219-489-2261	www.kamaya.com
M/A COM	1-800-366-2266	1-800-618-8883	www.macom.com
Murata	949-852-2001	949-852-2002	www.murata.com

Evaluates: MAX3524

MAX3524 Evaluation Kit

Evaluates: MAX3524

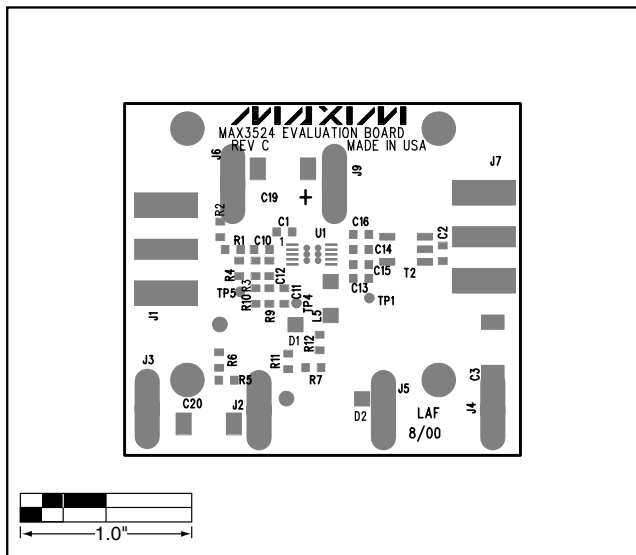

Figure 2. MAX3524 EV Kit Component Placement Guide—Component Side

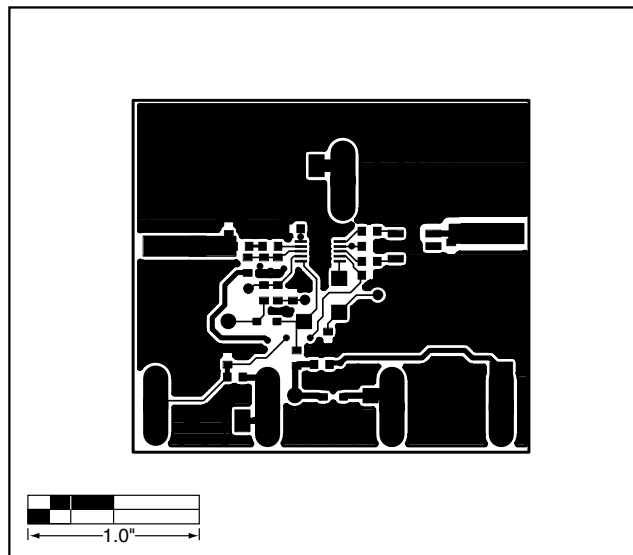

Figure 3. MAX3524 EV Kit PC Board Layout—Component Side

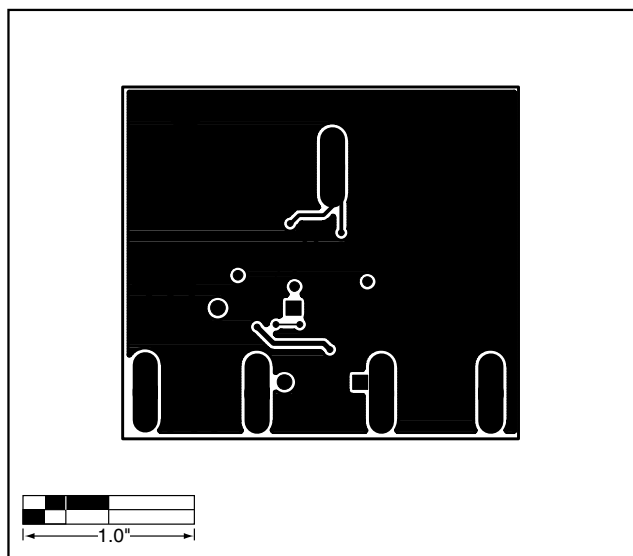

Figure 4. MAX3524 EV Kit PC Board Layout—Ground Side

Maxim cannot assume responsibility for use of any circuitry other than circuitry entirely embodied in a Maxim product. No circuit patent licenses are implied. Maxim reserves the right to change the circuitry and specifications without notice at any time.

Maxim Integrated Products, 120 San Gabriel Drive, Sunnyvale, CA 94086 408-737-7600 _____ 5

© 2000 Maxim Integrated Products

Printed USA

MAXIM is a registered trademark of Maxim Integrated Products.

www.BDTIC.com/maxim