



MAX3625 Evaluation Kit

General Description

The MAX3625 evaluation kit (EV kit) is an assembled demonstration board that provides convenient evaluation of the MAX3625 low-jitter, precision clock generator. The EV kit includes an on-board 25MHz crystal to allow immediate testing.

The EV kit includes switches to allow easy selection of different modes of operation. The reference input and clock outputs use SMA connectors and are AC-coupled to simplify connection to test equipment.

Ordering Information

PART	TEMP RANGE	IC PACKAGE
MAX3625EVKIT	0°C to +70°C	24 TSSOP

Features

- ◆ AC-Coupled I/Os for Ease of Testing
- ◆ Fully Assembled and Tested
- ◆ +3.3V Power-Supply Operation
- ◆ On-Board 25MHz Crystal

Part Suppliers

SUPPLIER	WEBSITE
NDK	www.ndk.com

Component List

DESIGNATION	QTY	DESCRIPTION
C1, C3, C4, C5, C7, C8, C11–C16, C18, C19	14	0.1 μ F \pm 10% ceramic capacitors (0402)
C2	1	10 μ F \pm 10% ceramic capacitor (0603)
C6, C17, C20	3	0.01 μ F \pm 10% ceramic capacitors (0402)
C9	1	33pF \pm 10% ceramic capacitor (0402)
C10	1	27pF \pm 10% ceramic capacitor (0402)
J1, J3, J5	0	Not installed
J2, J48	2	Test points
J4	1	2-pin header, 0.1in centers
J13–J16, J18, J19, J36	7	SMA connectors

DESIGNATION	QTY	DESCRIPTION
L1	1	2.7 μ H inductor
R1–R4, R12, R13	6	150 Ω \pm 5% resistors (0402)
R5, R6	0	Not installed
R7–R10, R14, R15, R16	7	49.9 Ω \pm 1% resistor (0402)
R11	1	10.5 Ω \pm 1% resistor (0402)
SW1, SW2, SW3, SW11	4	SP3T switches
SW6, SW8, SW9, SW12, SW13	5	SPDT switches
TP6, TP7	2	Test points
U1	1	MAX3625CUG+
Y1	1	25MHz crystal NDK EXS00A-AT00429
None	1	Shunt
None	1	PCB: MAX3625 Board, Rev A

Evaluates: MAX3625

MAX3625 Evaluation Kit

Quick Start

To evaluate the MAX3625, configure the EV kit as follows:

- 1) Determine which output is going to be evaluated and remove the 49.9Ω termination resistors located near the connectors. Then connect that output to the test equipment using SMA cables.
- 2) Connect a +3.3V power supply to J48 (VCC) and J2 (GND). Set the current limit to 200mA.
- 3) If the on-board crystal is used (IN_SEL set high), the PLL divider should be set to divide by 25 (FB_SEL set low) to achieve the standard output rates shown in Table 3.
- 4) Use Table 3 to set the output divider switches to achieve the output frequency desired.
- 5) Enable the output under test by setting the related output-enable switch, Qx_OE, high.

Table 1. Adjustment and Control Descriptions (see Quick Start first)

COMPONENT	NAME	FUNCTION
J4	INDUCTOR SHUNT	J4 shunts the power-supply inductor. Normal operation is J4 shunted.
SW1	SELB1	SW1 and SW2 set the output divider for the QB outputs. See Table 2 for more information.
SW2	SELB0	SW1 and SW2 set the output divider for the QB outputs. See Table 2 for more information.
SW3	SELA1	SW3 and SW11 set the output divider for the QA outputs. See Table 2 for more information.
SW6	$\overline{\text{BYPASS}}$	Set low to bypass the PLL. Set high to engage the PLL. Note that when the PLL is bypassed, the output dividers are automatically set to divide by 1.
SW8	FB_SEL	Sets the PLL divider. See Table 3 for more information.
SW9	QA_OE	Set high to enable LVPECL output QA. Set low to force a logic zero at QA.
SW11	SELA0	SW3 and SW11 set the output divider for the QA outputs. See Table 2 for more information.
SW12	QB_OE	Set high to enable LVPECL output QB. Set low to force a logic zero at QB1 and QB0.
SW13	IN_SEL	Set high to select the crystal as the frequency source. Set low to select the REF_IN as the frequency source.

Table 2. PLL Divider Settings

FB_SEL INPUT	PLL DIVIDER
LOW	÷24
HIGH	÷25

Table 3. Output Divider Settings

INPUT		NA/NB DIVIDER	OUTPUT FREQUENCY (MHz)
SELA1/SELB1	SELA0/SELB0		M = 25 AND XTAL = 25MHz
LOW	LOW	÷ 1	625*
LOW	HIGH	÷ 2	312.5
HIGH	LOW	÷ 4	156.25
HIGH	HIGH	÷ 5	125

*625MHz is beyond the maximum specified operating frequency.

MAX3625 Evaluation Kit

Evaluates: **MAX3625**

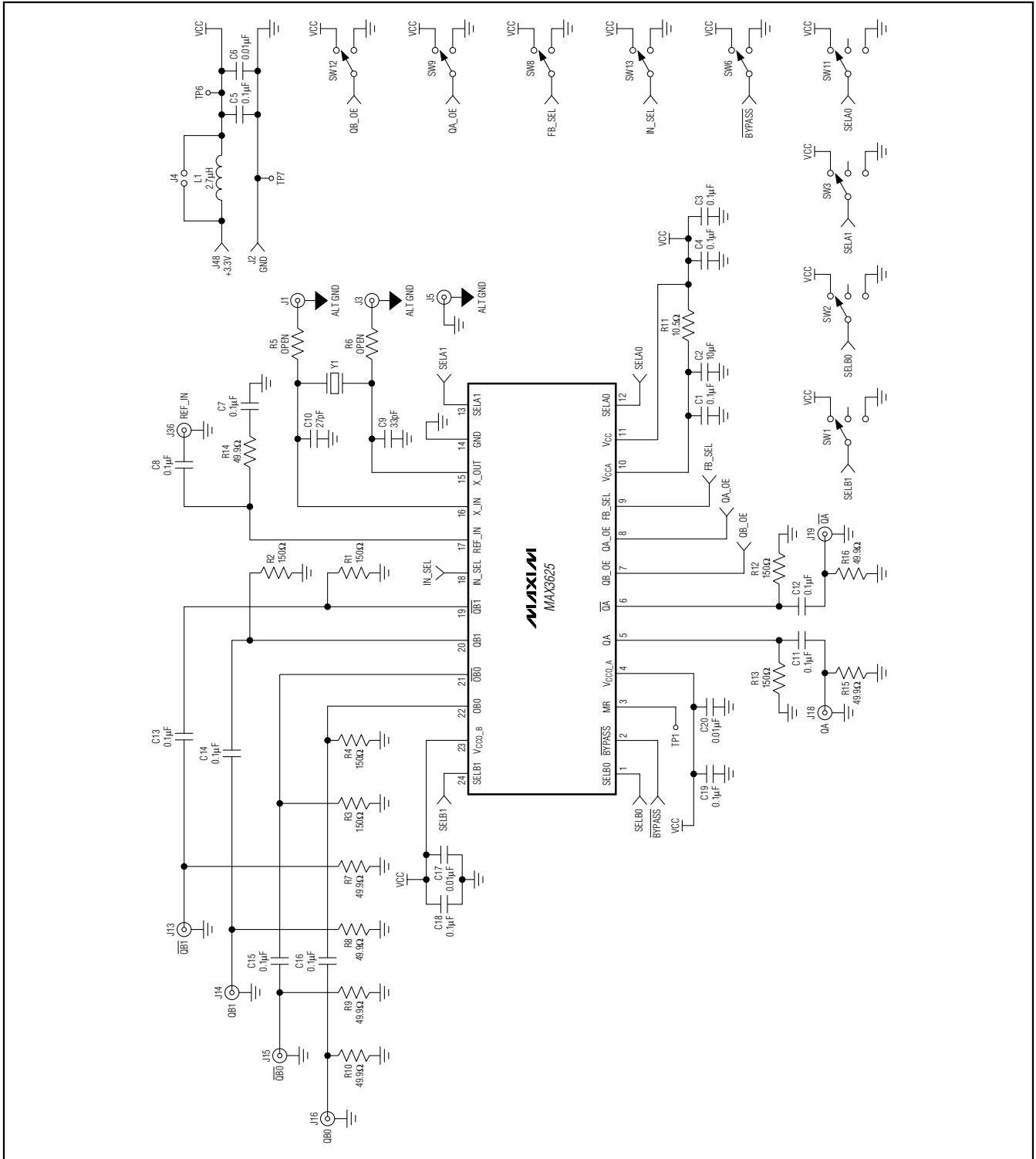

Figure 1. MAX3625 EV Kit Schematic

MAX3625 Evaluation Kit

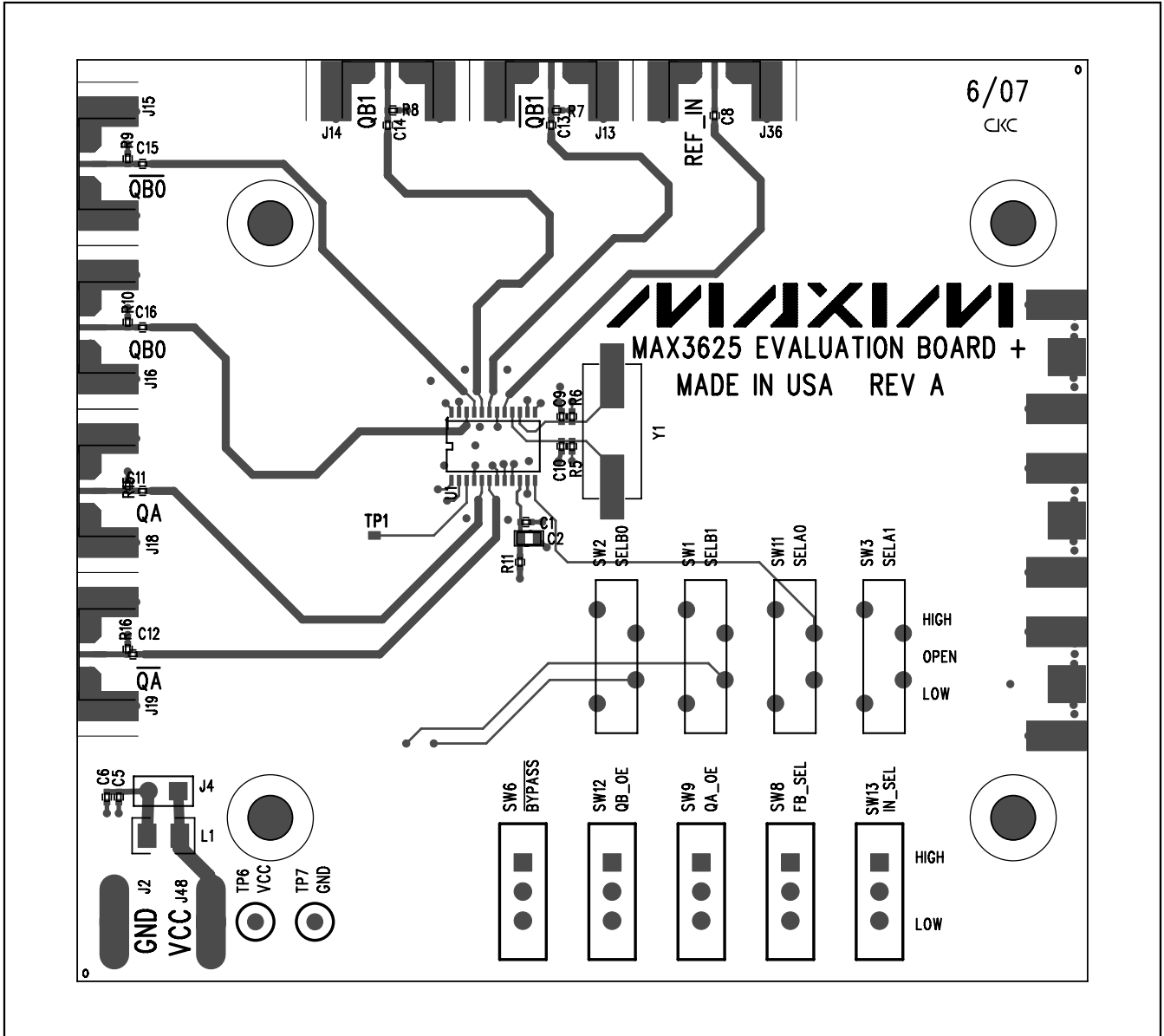

Figure 2. MAX3625 EV Kit Assembly Drawing—Top Side

MAX3625 Evaluation Kit

Evaluates: MAX3625

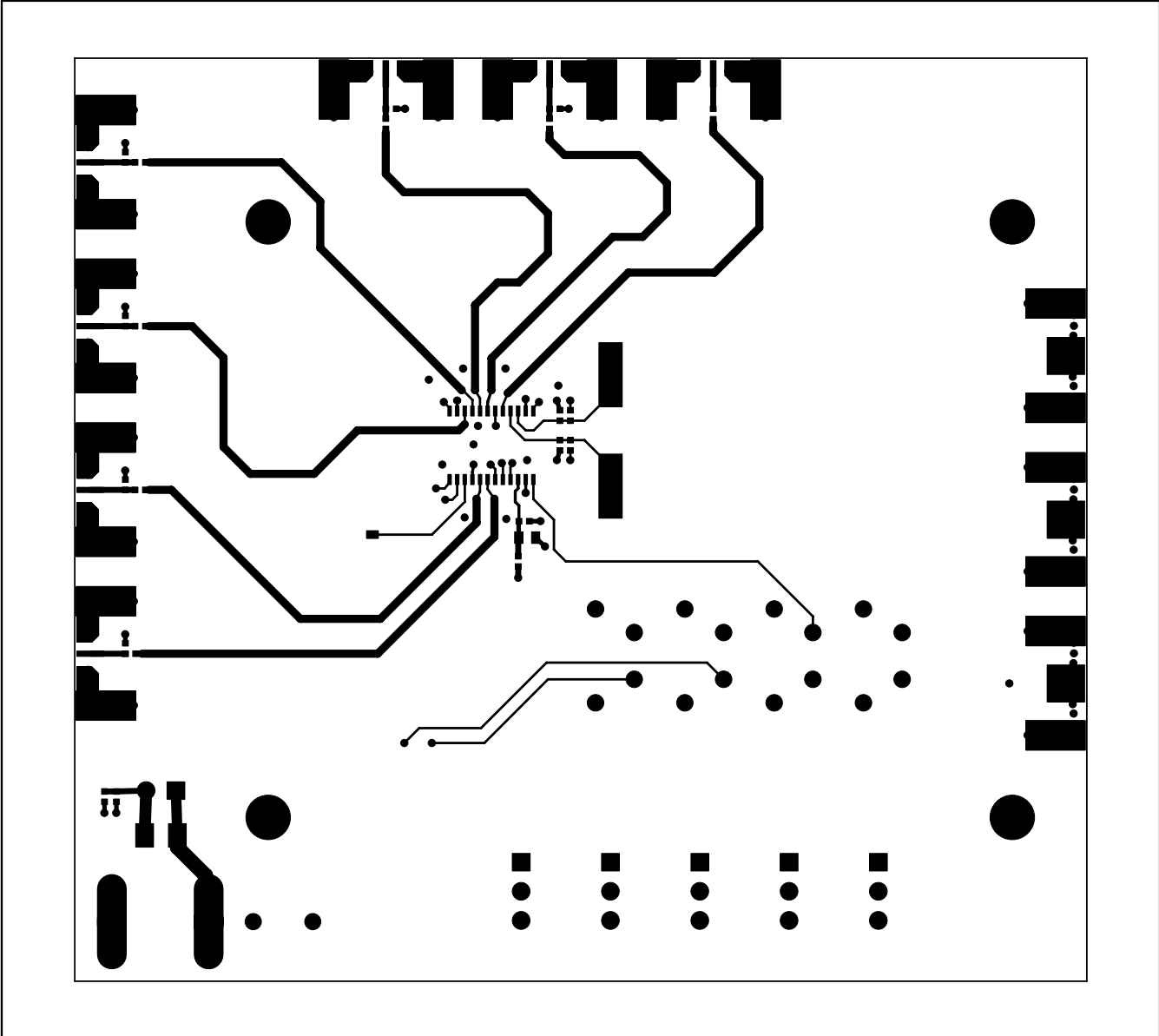

Figure 3. MAX3625 EV Kit Layout—Component Side

MAX3625 Evaluation Kit

Evaluates: MAX3625

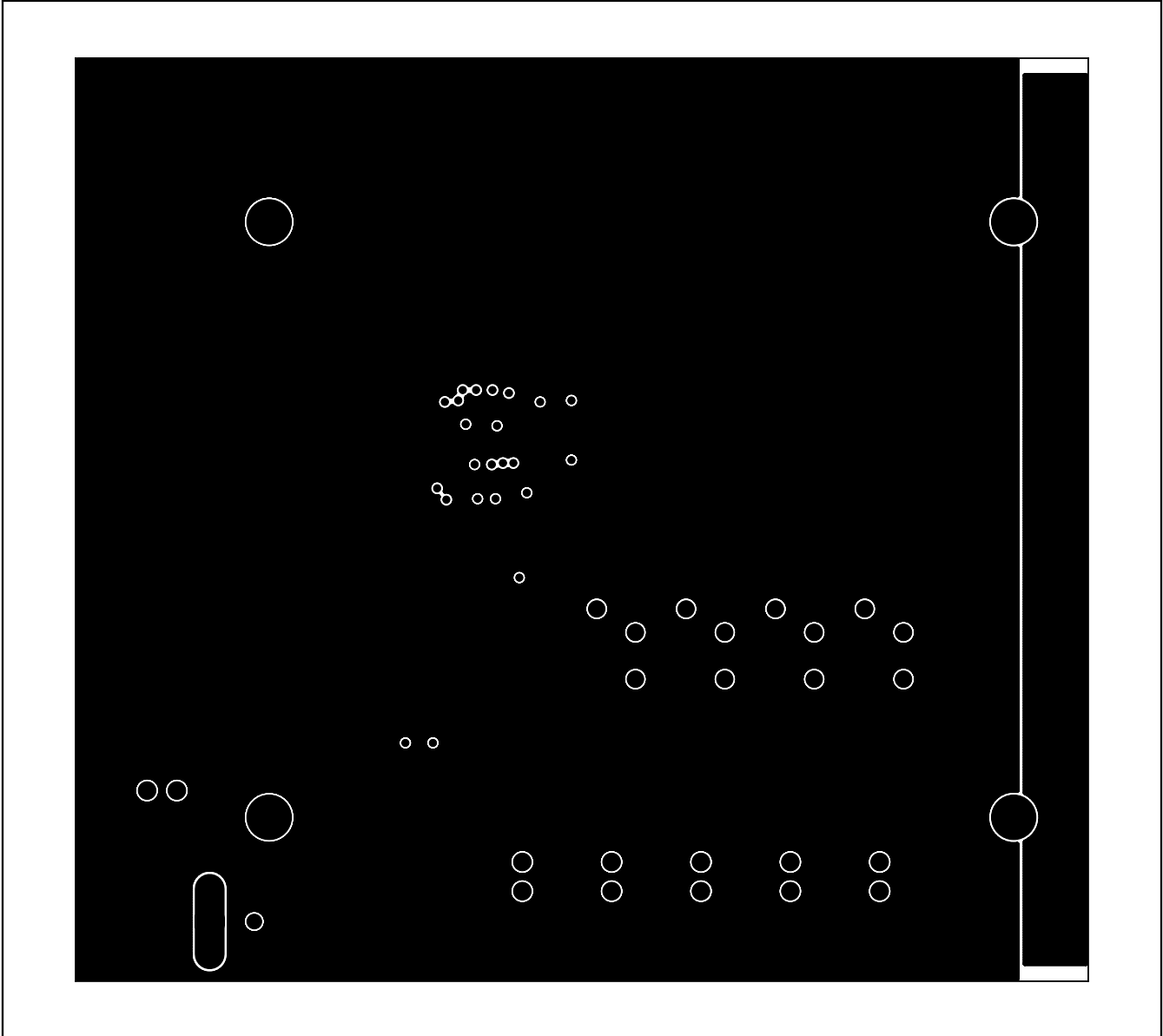

Figure 4. MAX3625 EV Kit Layout—Ground Plane

MAX3625 Evaluation Kit

Evaluates: MAX3625

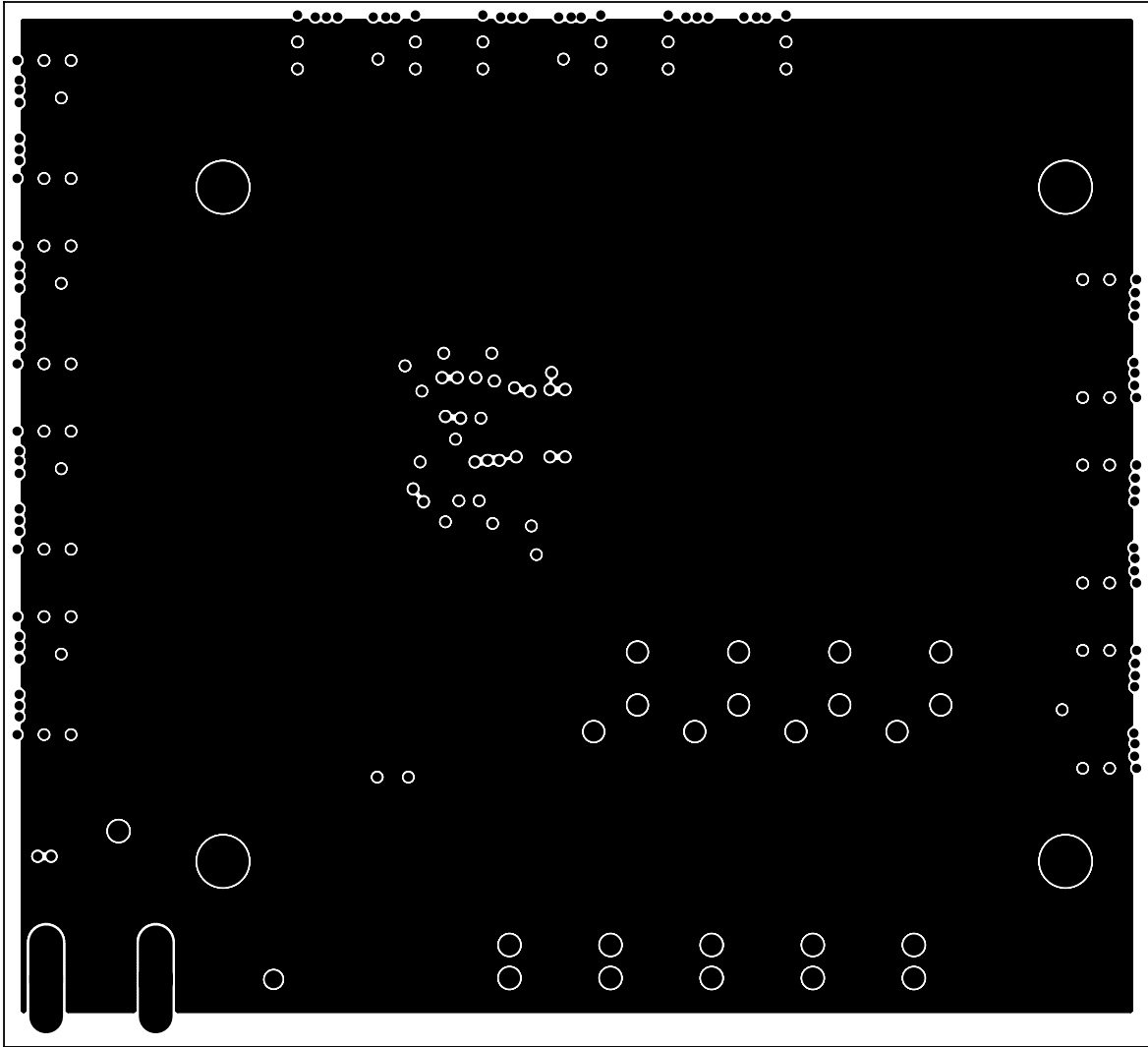

Figure 5. MAX3625 EV Kit Layout—Power Plane

MAX3625 Evaluation Kit

Evaluates: MAX3625

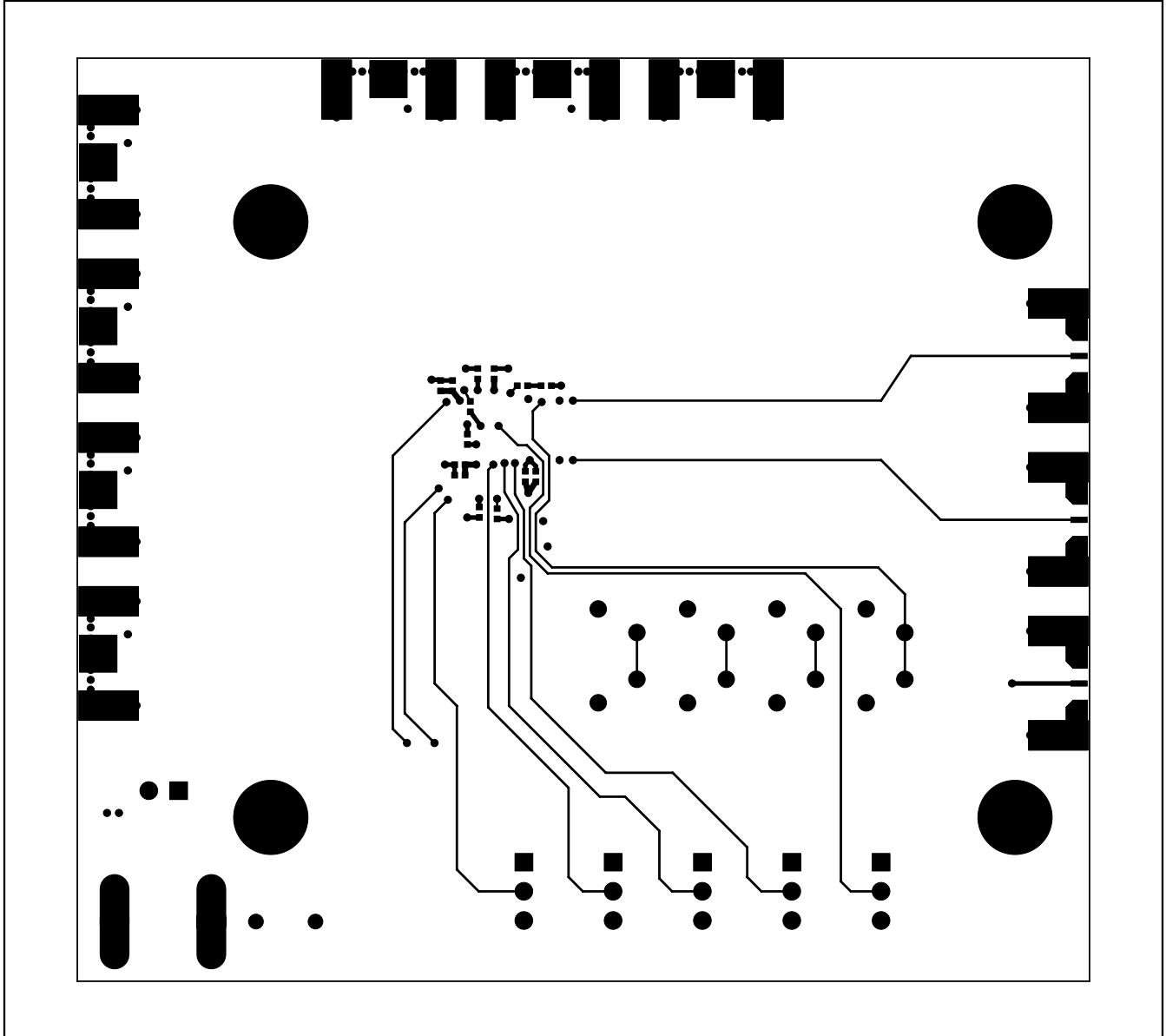

Figure 6. MAX3625 EV Kit Layout—Solder Plane

MAX3625 Evaluation Kit

Evaluates: MAX3625

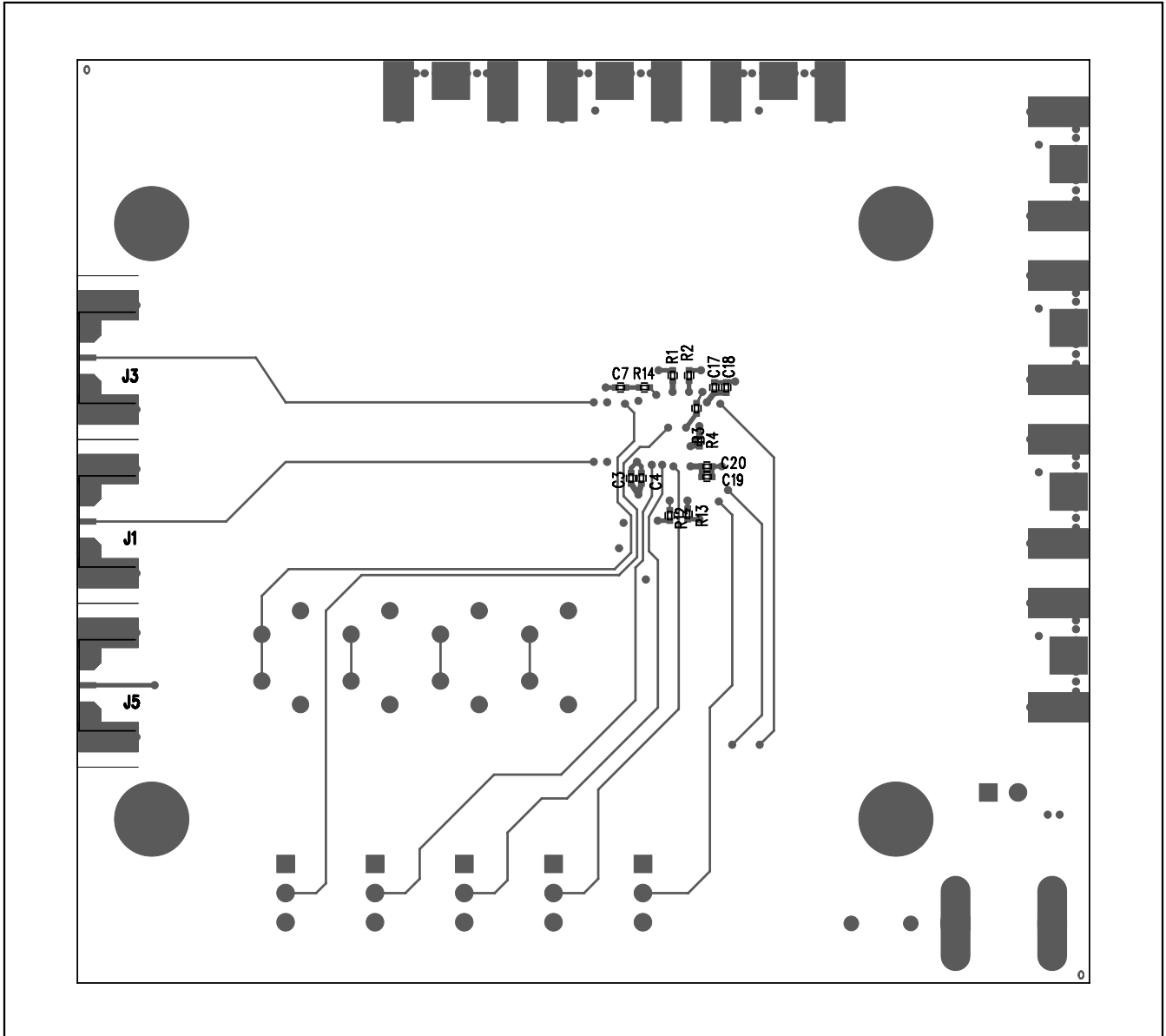

Figure 7. MAX3625 EV Kit Assembly Drawing—Bottom Side

Maxim cannot assume responsibility for use of any circuitry other than circuitry entirely embodied in a Maxim product. No circuit patent licenses are implied. Maxim reserves the right to change the circuitry and specifications without notice at any time.

Maxim Integrated Products, 120 San Gabriel Drive, Sunnyvale, CA 94086 408-737-7600 _____ 9

© 2007 Maxim Integrated Products

MAXIM is a registered trademark of Maxim Integrated Products, Inc.

www.BDTIC.com/maxim