



MAX688-4A Evaluation Kit

General Description

The MAX688-4A evaluation kit (EV kit) provides a regulated 3.3V output voltage while operating on input voltages from 3.5V to 11V. It delivers up to 4A output current from a 4.5V to 5.5V input, with low dropout.

The MAX688-4A EV kit is a fully assembled and tested printed circuit board. The board comes with a 3.3V-output MAX688 IC installed, but can also be used to evaluate the MAX689 (3.0V output).

Component List

DESIGNATION	QTY	DESCRIPTION
C3	1	1 μ F ceramic capacitor Marcon THCR30E1E105M
C4	1	4.7 μ F, 16V tantalum capacitor Sprague 595D475X0016A2B
C1, C2	2	150 μ F, 35V aluminum electrolytic caps. Nichicon UPL1V151MPH6 or Sanyo 35MV150GX
C16	1	0.01 μ F ceramic capacitor
C5	1	1200 μ F, 16V aluminum electrolytic cap. Nichicon UPL1C122MRH6 or Sanyo 16MV1200GX OR 1000 μ F, 25V aluminum electrolytic cap. Sanyo 25MV100GX
R4	1	10 Ω , 5% resistor
R1	1	100k Ω , 5% resistor
R3	1	1k Ω , 5% resistor
Q1	1	PNP power transistor (TO-220) Motorola TIP42A
Q2	1	PNP transistor, Motorola 2N4403
None	1	Heatsink, Thermalloy 6072B
U1	1	Maxim MAX688CSA (8-pin SO)
JU1	1	3-pin header
JU2	1	2-pin header
None	2	Shunt
None	1	PC board
None	1	MAX688 data sheet

Features

- ◆ 3.5V to 11V Input Supply Range
- ◆ 3.3V Output Voltage
- ◆ Up to 4A Output Current
- ◆ <0.02 μ A/MAX688 Shutdown Supply Current
- ◆ 150 μ A Quiescent Current
- ◆ External PNP Pass Transistor
- ◆ Adjustable Current Limit
- ◆ Fully Assembled and Tested

Ordering Information

PART	TEMP. RANGE
MAX688EVKIT-4A	0°C to +70°C

Component Suppliers

SUPPLIER	PHONE	FAX
AVX	(803) 946-0238	(803) 626-3123
IRC	(213) 772-2000	(213) 772-9028
Marcon	(708) 913-9980	(708) 913-1150
Sanyo	(619) 661-6835	(619) 661-1055
Sprague	(508) 339-8900	(508) 339-5063

Quick Start

The MAX688-4A EV kit is a fully assembled and tested board. Follow these steps to verify board operation. **Do not turn on the power supply until all connections are completed.**

- 1) Connect a 5V power supply to the pad marked VIN. The ground connects to the GND pad.
- 2) Connect a voltmeter and load (if any) to the VOUT pad.
- 3) Place one shunt across JU1 pins 2 and 3 and the other shunt across JU2 for normal operation.
- 4) Turn on the power and verify that the output voltage is 3.3V.

Instructions for modifying the board for a 3.0V output appear in the section *Evaluating the MAX689*.

Evaluates: MAX688/MAX689

MAX688-4A Evaluation Kit

Detailed Description

Shutdown Function

The MAX688 has an active-low shutdown control input to turn its output on or off at any time. The 3-pin header JU1 selects the shutdown mode. Remove the shunt when driving shutdown with an external signal. Table 1 lists the jumper selectable options.

Table 1. Jumper JU1 Functions

SHUNT LOCATION	SHDN PIN	MAX688 OUTPUT
2 & 3	Connected to VIN	MAX6884A Enabled, V _{OUT} = 3.3V
2 & 1	Connected to GND	Shutdown Mode, V _{OUT} = 0V

Evaluating the MAX689

The MAX688 can be replaced with a MAX689 to generate a 3.0V output voltage with output current up to 4A. The only modification required is to replace the IC.

Base-Current Limiting

The output current can be limited by installing a current-limiting resistor, R2, between BASE (pin 7) and BLIM (pin 6) of U1. This EV kit comes with a shunt across JU2, which limits base current to 20mA.

For lower base current limit, refer to the MAX687/ MAX688/MAX689 data sheet for instructions on selecting the current-limiting resistor value.

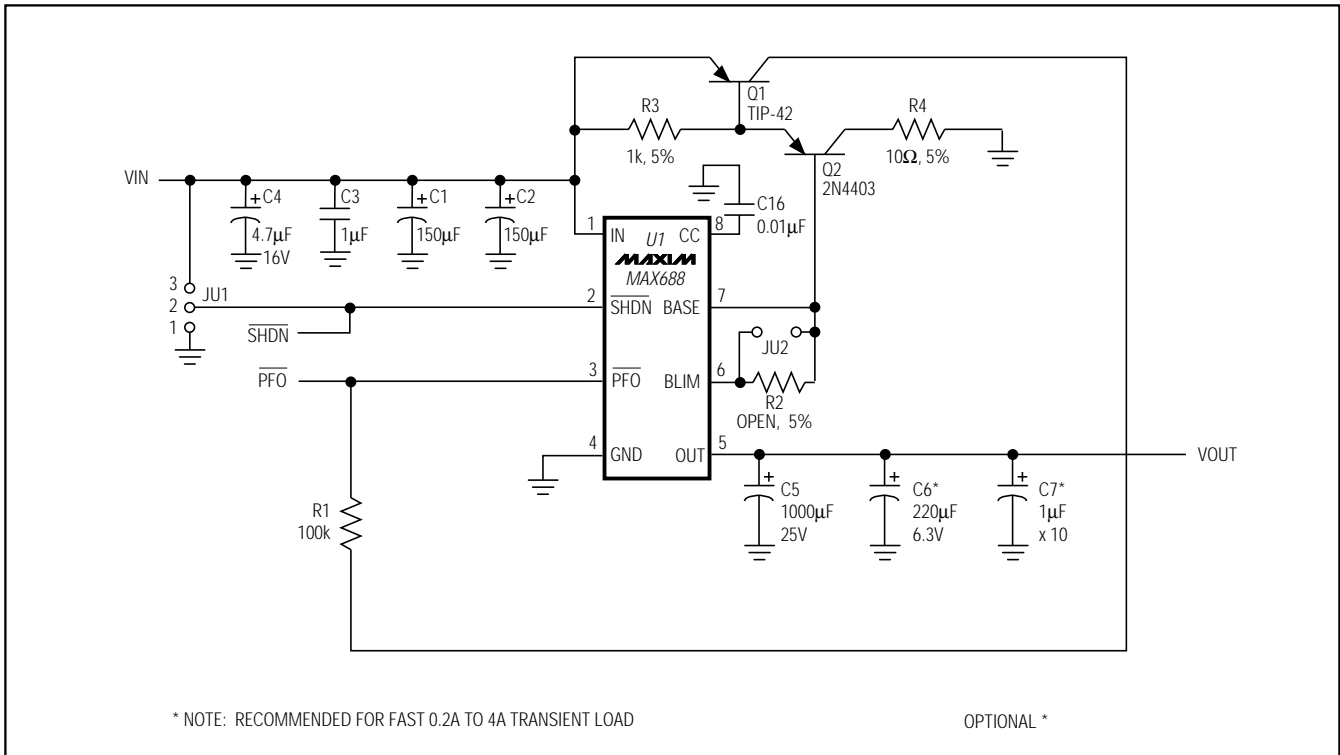

Figure 1. MAX688-4A EV Kit Schematic Diagram

MAX688-4A Evaluation Kit

Evaluates: MAX688/MAX689

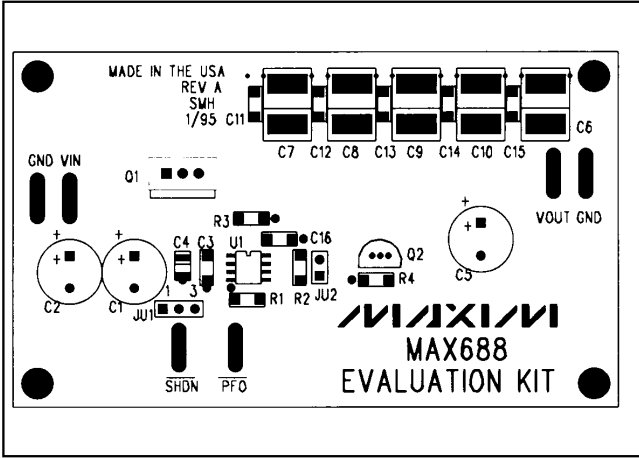

Figure 2. Component Placement Guide—Component Side

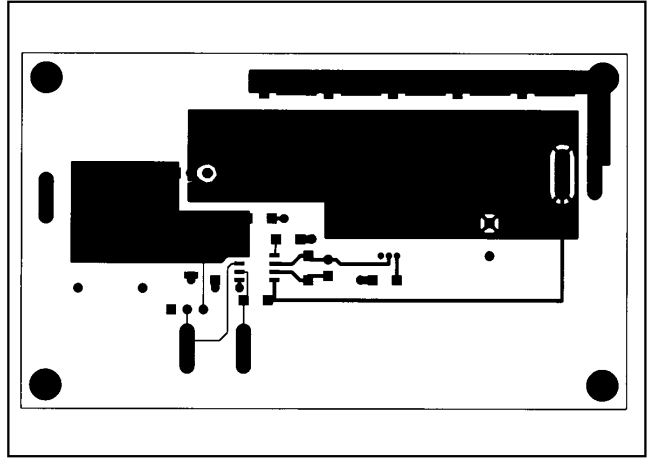

Figure 3. PC Board Layout—Component Side

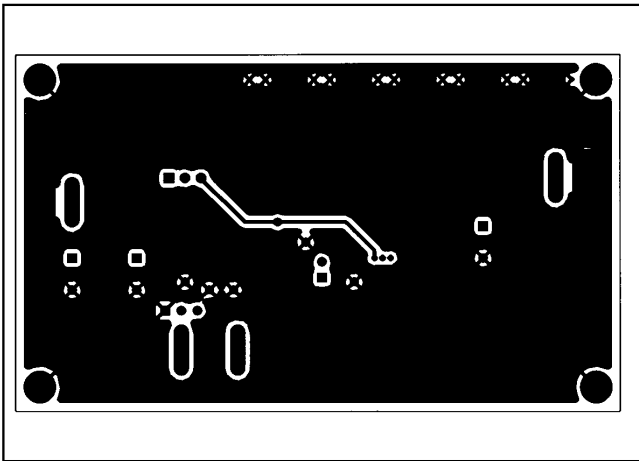

Figure 4. PC Board Layout—Solder Side

MAX688-4A Evaluation Kit

Evaluates: MAX688/MAX689

Maxim cannot assume responsibility for use of any circuitry other than circuitry entirely embodied in a Maxim product. No circuit patent licenses are implied. Maxim reserves the right to change the circuitry and specifications without notice at any time.

4 _____ Maxim Integrated Products, 120 San Gabriel Drive, Sunnyvale, CA 94086 (408) 737-7600

© 1995 Maxim Integrated Products

Printed USA

MAXIM is a registered trademark of Maxim Integrated Products.

<http://www.BDTIC.com/MAXIM>