

2.54mm [.100"] CENTERLINE
 1.25mm [.049"] CENTERLINE
 1.00mm [.039"] CENTERLINE
 0.50mm [.020"] CENTERLINE

PCB SERIES

INTRODUCTION:

Adam Tech PCB Series Flexible Printed Circuit (FPC) and Flexible Flat Cable (FFC) connectors are a LIF (low insertion force) design that provides a low cost, fast, easy and reliable connection of flexible printed circuits to a PCB. Adam Tech's special contact design preserves conductor integrity while producing a stable, high pressure connection. This series includes single and dual row versions in 2.54mm, 1.25mm, 1.00mm & 0.50mm centerlines with vertical or horizontal orientations.

FEATURES:

Superior contact design protects conductors
 High pressure contacts
 Single or dual row versions
 Choice of 2.54mm, 1.25mm, 1.00mm & 0.50mm centerlines

MATING FPC & FFC CABLE:

Mates with flat flexible cable and flexible printed circuits with thickness of 0.3mm

Specifications:

Material:

Standard insulator: PBT, Glass reinforced, rated UL94V-0
 Optional Hi-Temp insulator: Nylon 6T, rated UL94V-0
 Insulator color: Black
 Contacts: Phosphor Bronze

Contact Plating:

Tin over copper underplate

Electrical:

Operating voltage: 100V AC max.
 Current rating: .039" Spacing: 0.5 Amp max.
 .049" Spacing: 1 Amp max
 .100" Spacing: 3 Amps max

Contact resistance: 30 mΩ max. initial
 Insulation resistance: 500 MΩ min.
 Dielectric withstanding voltage: 500V AC for 1 minute

Mechanical:

Insertion Force: 5 oz max
 Withdrawal Force: 3 oz min

Temperature Rating:

Operating temperature: -40°C to +85°C
 Soldering process temperature:
 Standard insulator: 235°C
 Hi-Temp insulator: 260°C

PACKAGING:

Anti-ESD plastic tubes or trays

APPROVALS AND CERTIFICATIONS:

UL Recognized & CSA Certified, File no. E224053

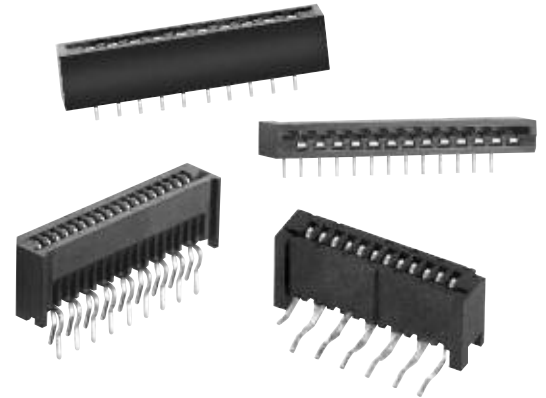

ORDERING INFORMATION

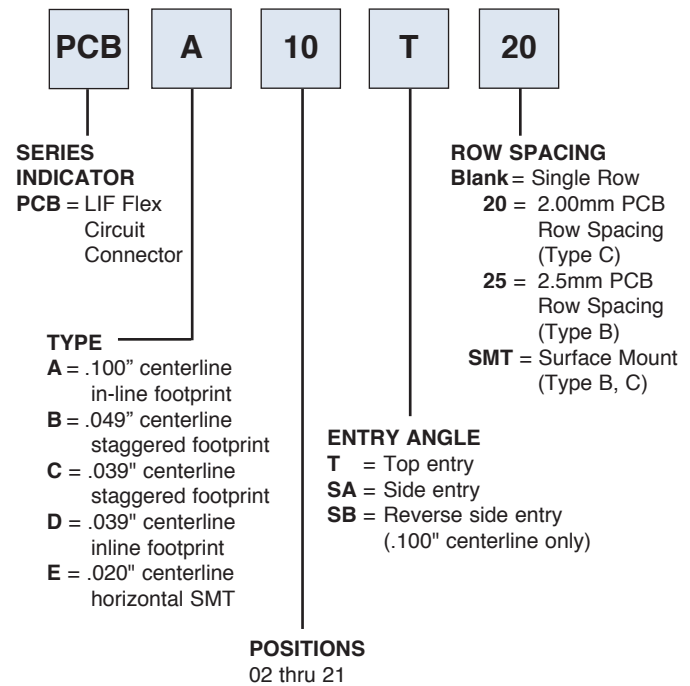

OPTIONS

Add designator(s) to end of part number
 HT= Hi-Temp insulator for Hi-Temp soldering processes up to 260°C

PCB-C
1.00 (.039") TOP ENTRY SMT

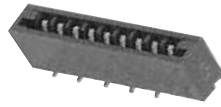

PCB-C-09-T-SMT

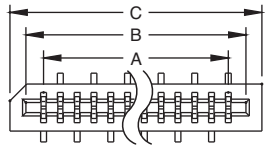

A = .039 [1.00] X No. of Spaces
B = A + .090 [2.30]
C = A + .157 [4.00]

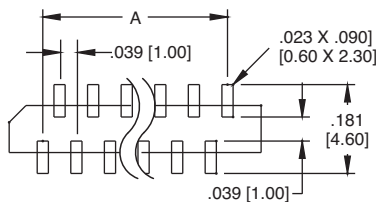
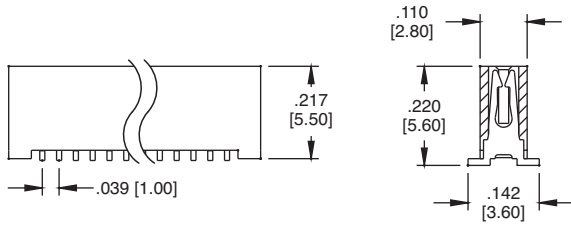

Recommended PCB Layout

PCB-C
1.00 (.039") SIDE ENTRY SMT



PCB-C-18-SA-SMT

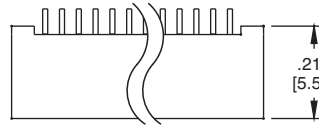

A = .039 [1.00] X No. of Spaces
B = A + .090 [2.30]
C = A + .157 [4.00]

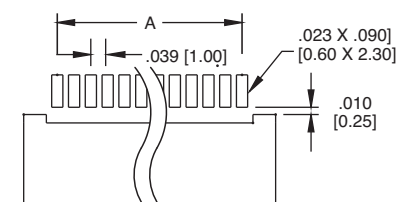
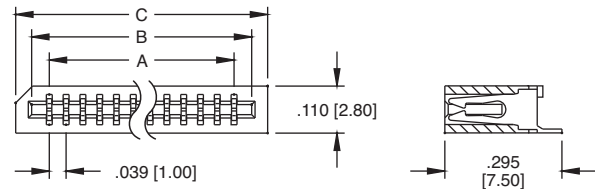

Recommended PCB Layout

PCB-C
1.00 (.039") TOP ENTRY THRU HOLE

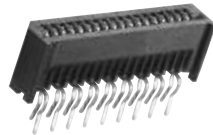

PCB-C-18-T-20

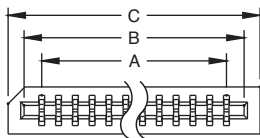

A = .039 [1.00] X No. of Spaces
B = A + .090 [2.30]
C = A + .157 [4.00]

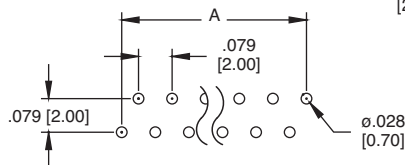
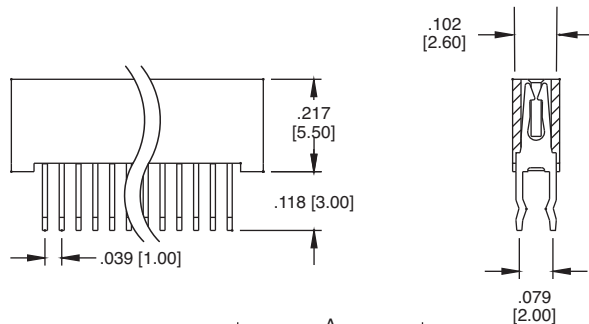

Recommended PCB Layout

PCB-C
1.00 (.039") SIDE ENTRY THRU HOLE

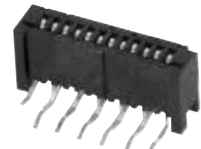

PCB-C-12-SA-20

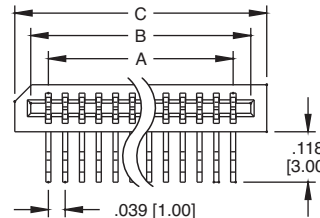

A = .039 [1.00] X No. of Spaces
B = A + .090 [2.30]
C = A + .157 [4.00]

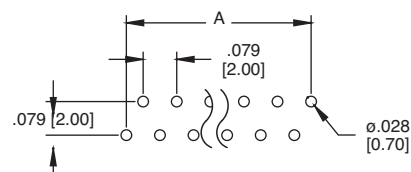
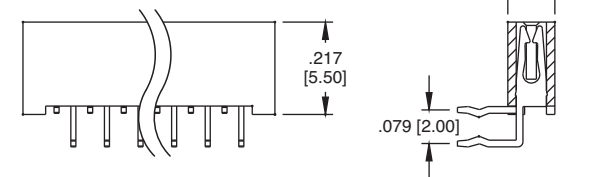

Recommended PCB Layout

PCB-B

1.25 (.049") TOP ENTRY THRU HOLE

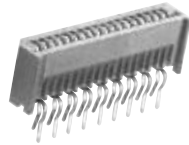
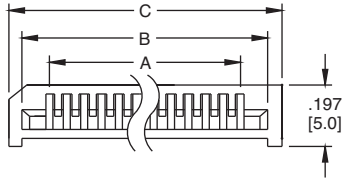

PCB-B-18-T-25

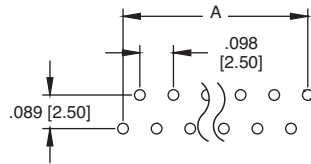
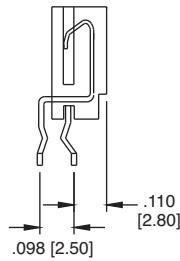
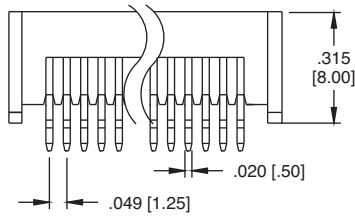

A = .049 [1.25] X No. of Spaces
 B = A + .098 [2.50]
 C = A + .197 [5.00]

Recommended PCB Layout

PCB-B

1.25(.049") SIDE ENTRY THRU HOLE

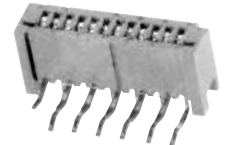
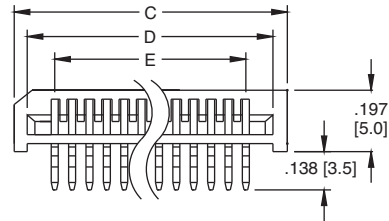

PCB-B-12-SA-25

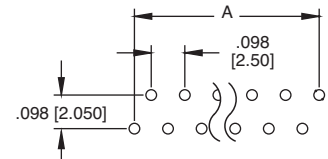
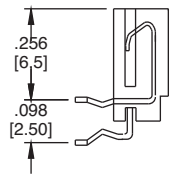
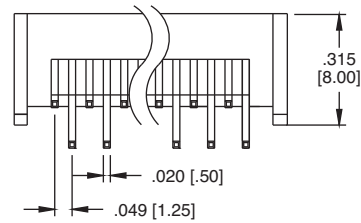

A = .049 [1.25] X No. of Spaces
 B = A + .098 [2.50]
 C = A + .197 [5.00]

Recommended PCB Layout

PCB-A

.100" (2.54) TOP ENTRY INLINE THRU HOLE

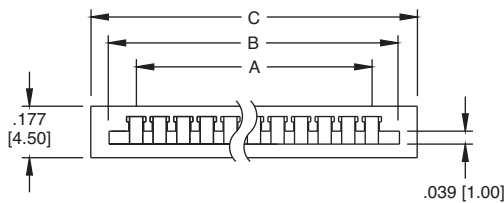

PCB-A-10-T

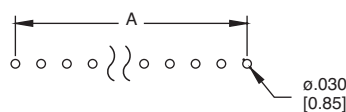
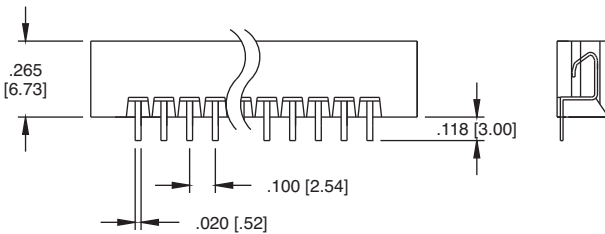

A = .100 [2.54] x no. of Spaces
 B = A + .232 [5.90]
 C = A + .315 [8.00]

Recommended PCB Layout

PCB-A

.100" (2.54) SIDE ENTRY INLINE THRU HOLE

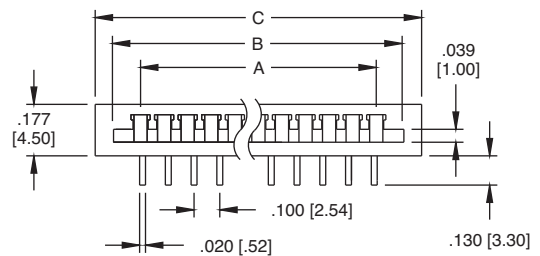

PCB-A-13-SA

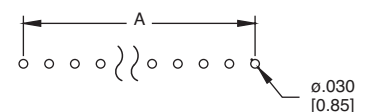
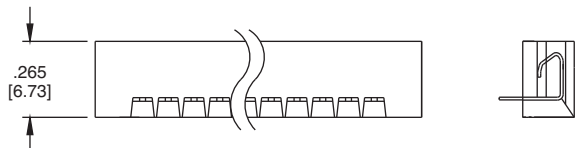

A = .100 [2.54] x no. of Spaces
 B = A + .232 [5.90]
 C = A + .315 [8.00]

Recommended PCB Layout

0.3mm [.012"] CENTERLINE
 0.5mm [.020"] CENTERLINE
 0.8mm [.031"] CENTERLINE
 1.0mm [.039"] CENTERLINE
 1.25mm [.049"] CENTERLINE
 PCA SERIES

INTRODUCTION:

Adam Tech PCA Series Flexible Printed Circuit (FPC) and Flexible Flat Cable (FFC) connectors are ZIF (zero insertion force) connectors designed to provide a fast, easy, reliable method to make a connection of flexible printed circuits to a PCB. Adam Tech's special contact design completely preserves conductor integrity by eliminating all wiping action while making connection. Flex circuitry enters the connector and the connector cap is pressed down to capture the flex circuit producing a stable, high pressure connection. Raising the cap releases the pressure for exchange or replacement of circuitry. This series includes single and dual row versions in thru-hole or SMT mounting in vertical or horizontal orientations.

FEATURES:

Superior contact design protects conductors
 High pressure contacts
 Single or dual row versions
 Choice of .3mm, .5mm, .8mm, 1mm & 1.25mm centerlines

MATING FPC & FFC:

Mates with .3mm, .5mm, .8mm, 1mm & 1.25mm centerline flat flexible circuits with thickness range of 0.1mm to 0.3mm

SPECIFICATIONS:

Material:

Hi-Temp Insulator: LCP, Glass reinforced, rated UL94V-0
 Insulator color: Natural
 Contacts: Phosphor Bronze

Contact Plating:

Tin over copper underplate overall

Electrical:

Operating voltage: 100V AC max.
 Current rating: .020" Spacing: 0.4 Amps max.
 .031" & .039" Spacing: 0.5 Amps max
 .049" Spacing: 1 Amp max
 Contact resistance: 30 mΩ max. initial
 Insulation resistance: 500 MΩ min.
 Dielectric withstanding voltage: 500V AC for 1 minute

Mechanical:

Insertion Force: 0 oz max
 Withdrawal Force: 13 oz min

Temperature Rating:

Operating temperature: -40°C to +85°C
 Soldering process temperature: 260°C

PACKAGING:

Anti-ESD plastic tubes or Tape and Reel

APPROVALS AND CERTIFICATIONS:

UL Recognized & CSA Certified, File no. E224053

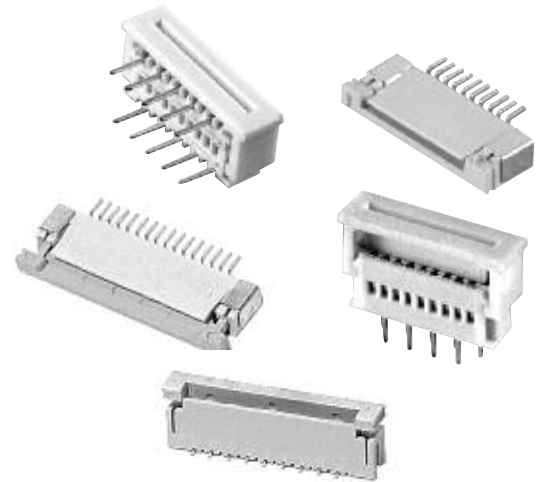

ORDERING INFORMATION

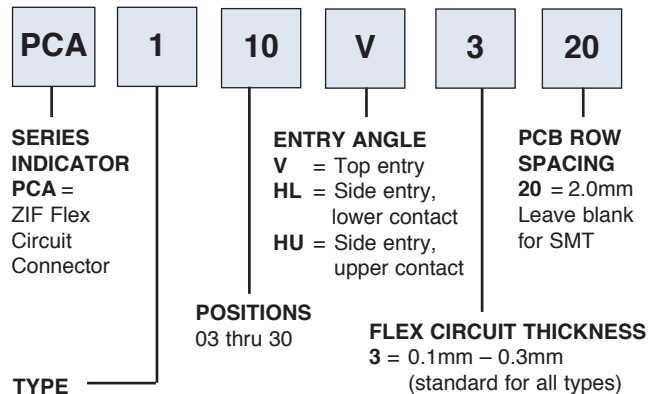

- TYPE**
- 1 = 1.25mm centerline thru-hole
 - 2 = 1.00mm centerline SMT (body height 2.70mm)
 - 2B = 1.00mm centerline SMT (body height 1.2mm)
 - 3 = 1.00mm centerline thru-hole
 - 4 = 1.25mm centerline SMT
 - 5 = .8mm centerline SMT
 - 6 = .5mm centerline SMT (body height 2.0mm)
 - 6A = .5mm centerline SMT (body height 1.5mm)
 - 6B = .5mm centerline SMT (body height 1.2mm)
 - 6C = .5mm centerline SMT (body height 1.0mm)
 - 7 = .3mm centerline SMT

OPTIONS:

Add designator(s) to end of part number
 TR = Tape and reel packaging

CONTACT SECTION VIEWS

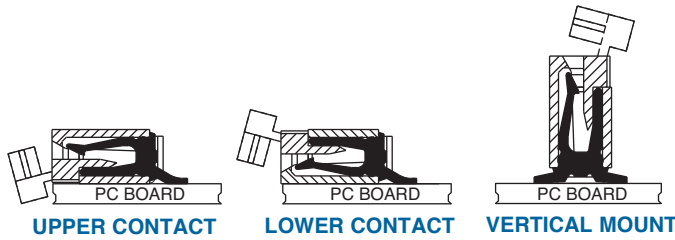

PCA-6 .5mm (.020") SIDE ENTRY SMT



PCA-6-16-HU-3

$$A = .020 [0.50] \times \text{No. of Spaces}$$

$$B = A + .045 [1.14]$$

$$C = A + .189 [6.60]$$

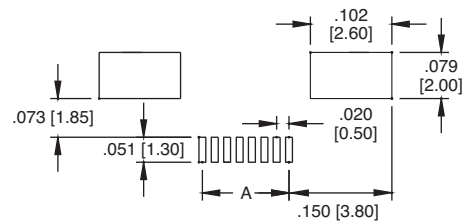
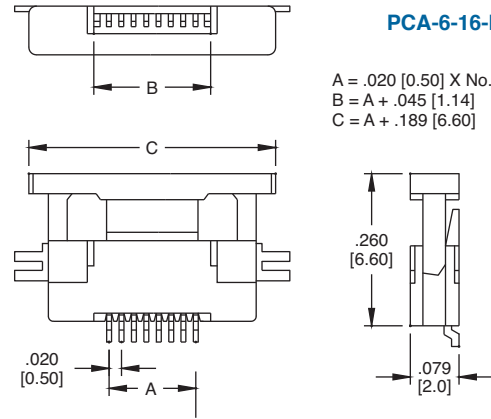

Recommended PCB Layout

PCA-7 .3mm (.012") SIDE ENTRY SMT



PCA-7-18-HL-3

$$A = .012 [0.30] \times \text{No. of Spaces}$$

$$B = A - .024 [0.60]$$

$$C = A + .025 [0.63]$$

$$D = A + .051 [1.30]$$

$$E = A + .071 [1.80]$$

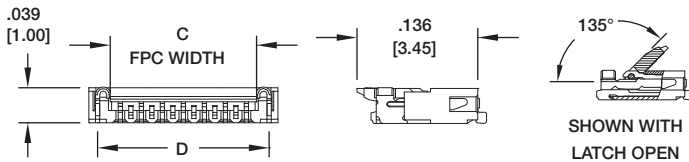
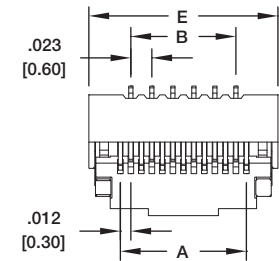

PCA-6 .5mm (.020") TOP ENTRY SMT



PCA-6-18-V-3

$$A = .020 [0.50] \times \text{No. of Spaces}$$

$$B = A + .045 [1.14]$$

$$C = A + .189 [6.60]$$

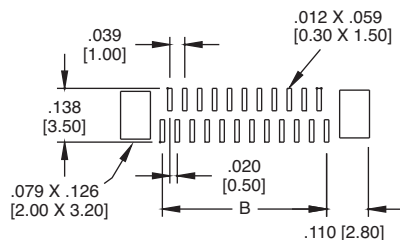
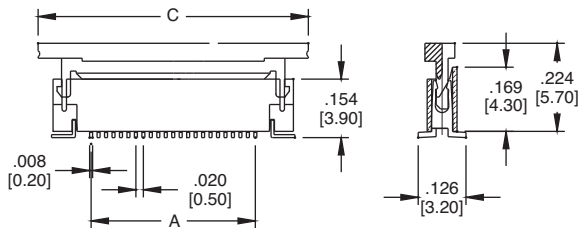
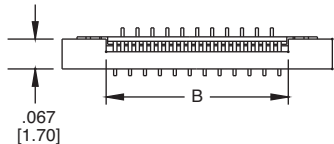

Recommended PCB Layout

PCA-5 .8mm (.031") SIDE ENTRY SMT



PCA-5-24-HU-3

$$A = .031 [0.80] \times \text{No. of Spaces}$$

$$B = A + .081 [2.05]$$

$$C = A + .228 [5.80]$$

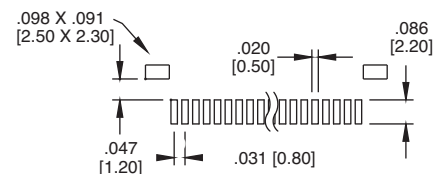
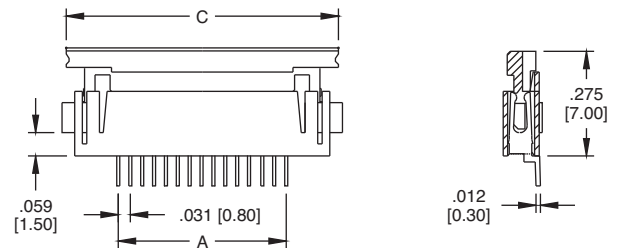
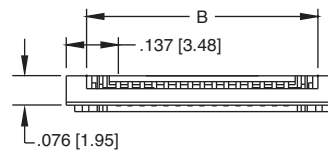

Recommended PCB Layout

PCA-2

1.00mm (.039")
SIDE ENTRY SMT

$$A = .039 [1.00] \times \text{No. of Spaces}$$

$$B = A + .090 [2.30]$$

$$C = A + .280 [7.10]$$



PCA-2-10-HU-3

Also Available in 1.2mm
& 1.5mm Body heights

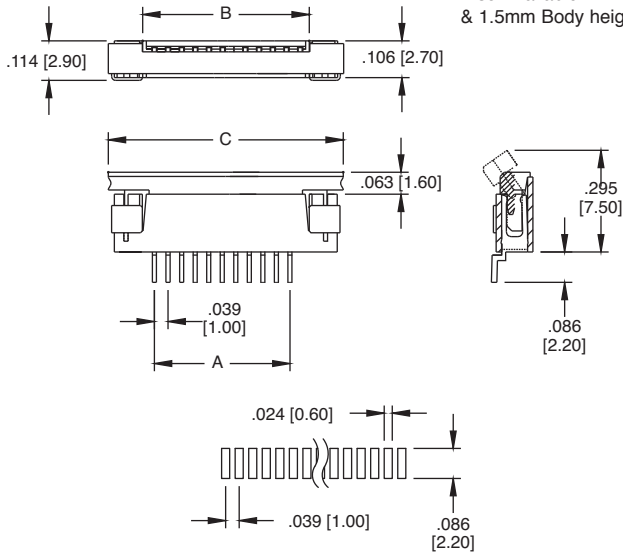

Recommended PCB Layout

PCA-2

1.00mm (.039")
TOP ENTRY SMT

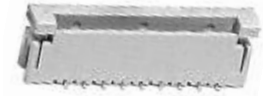

PCA-2-18-V-3

$$A = .039 [1.00] \times \text{No. of Spaces}$$

$$B = A + .090 [2.30]$$

$$C = A + .280 [7.10]$$

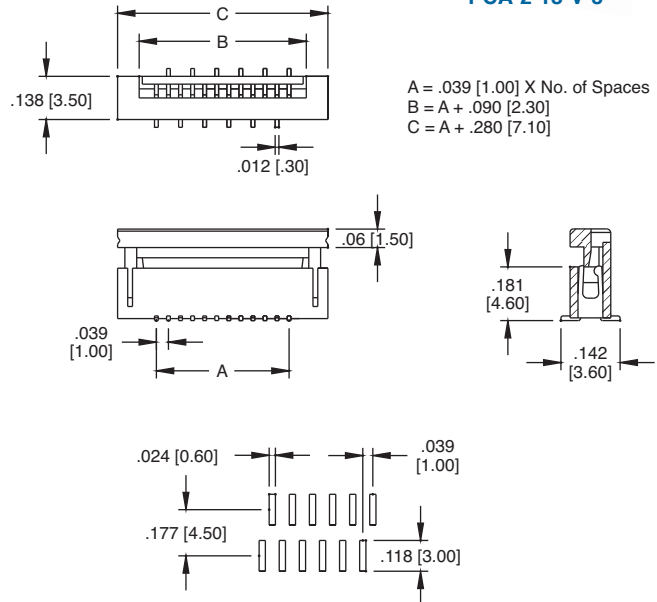

Recommended PCB Layout

PCA-1

1.25mm (.049")
TOP ENTRY THRU HOLE

$$A = .049 [1.25] \times \text{No. of Spaces}$$

$$B = A + .106 [2.70]$$

$$C = A + .303 [7.70]$$

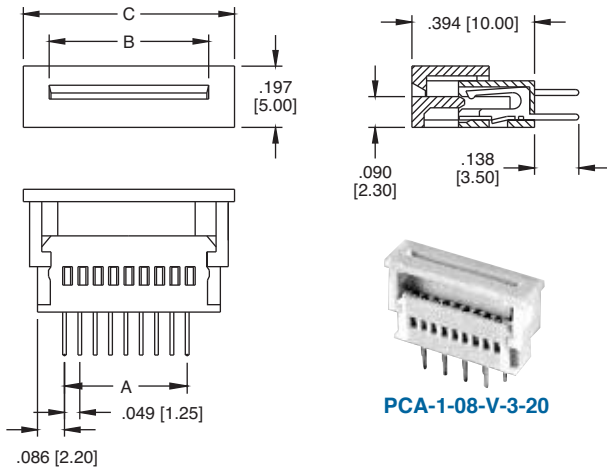

PCA-1-08-V-3-20

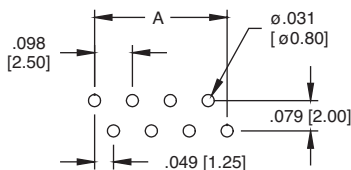

Recommended PCB Layout

PCA-1

1.25mm (.049")
TOP ENTRY THRU HOLE

$$A = .049 [1.25] \times \text{No. of Spaces}$$

$$B = A + .106 [2.70]$$

$$C = A + .303 [7.70]$$

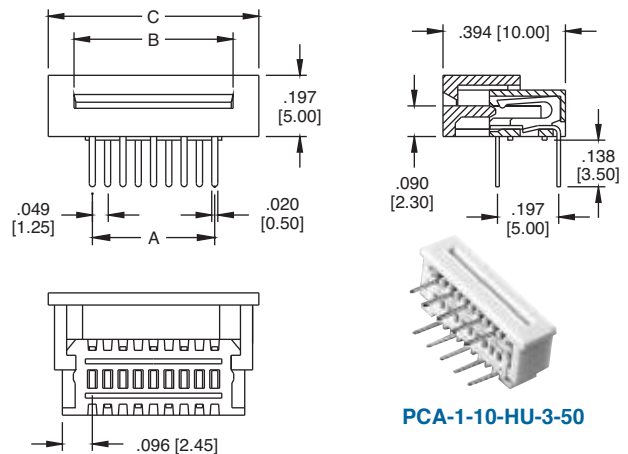

PCA-1-10-HU-3-50

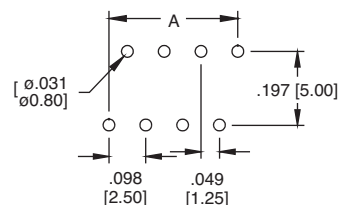

Recommended PCB Layout