

## Features

- **Clock Controller**
  - 80C51 core with 6 clocks per instruction
  - 8 MHz On-Chip Oscillator
  - PLL for generating 96 MHz clock to supply CPU core, USB and Smart Card Interfaces
  - Programmable CPU clock from 500 kHz / X1 to 48 MHz / X1
- **Reset Controller**
  - Power On Reset (POR) feature avoiding an external reset capacitor
  - Power Fail Detector (PFD)
  - Watch-Dog Timer
- **Power Management**
  - Two power saving modes: Idle and Power Down
  - Four Power Down Wake-up Sources: Smart Card Detection, Keyboard Interrupt, USB Resume, External Interrupt
  - Input Voltage Range: 4.5V - 5.5V
  - Core's Power Consumption (Without Smart Card and USB):
    - 30 mA Maximum Operating Current @ 48 MHz / X1
    - 200  $\mu$ A Maximum Power-down Current @ 5.5V
- **Interrupt Controller**
  - up to 7 interrupt sources
  - up to 4 Level Priority
- **Memory Controller**
  - Internal Program memory: up to 16 Kbytes of ROM
  - Internal Data Memory : 768 bytes including 256 bytes of data and 512 bytes of XRAM
- **Two 16-bit Timer/Counters**
- **USB 2.0 Full Speed Interface**
  - 48 MHz DPLL
  - On-Chip 3.3V USB voltage regulator and transceivers
  - Software detach feature
  - 7 endpoints programmable with In or out directions and ISO, Bulk or Interrupt Transfers :
    - Endpoint 0: 32 Bytes Bidirectionnal FIFO for Control transfers
    - Endpoints 1,2,3: 8 bytes FIFO
    - Endpoints 4,5: 64 Bytes FIFO
    - Endpoint 6: 2\*64 bytes FIFO with Pin-Pong feature
- **ISO 7816 UART Interface Fully Compliant with EMV2000, GIE-CB and WHQL Standards**
  - Programmable ISO clock from 1 MHz to 4.8 MHz
  - Card insertion/removal detection with automatic deactivation sequence
  - Programmable Baud Rate Generator from 372 to 11.625 clock pulses
  - Synchronous/Asynchronous Protocols T=0 and T=1 with Direct or Inverse Convention
  - Automatic character repetition on parity errors
  - 32 Bit Waiting Time Counter
  - 16 Bit Guard Time Counter
  - Internal Step Up/Down Converter with Programmable Voltage Output:
    - 1.8V-30mA, 3V-50mA and 5V-60mA
  - Current overload protection
  - 6 kV ESD (MIL/STD 883 Class 3) protection on whole Smart Card Interface
- **Alternate Smart Card Interface with CLK, IO and RST**
- **UART Interface with Integrated Baud Rate Generator (BRG)**
- **Four 12 I/O bit Ports**
  - Up to four LED outputs with 3 level programmable current source: 2, 4 and 10 mA
  - Two General Purpose I/O programmable as external interrupts
- **Packages**
  - VQFP32, QFN32, Die



## C51 Microcontroller with USB and Smart Card Reader Interfaces

### AT83C5127

## Summary

For detailed functional description,  
please refer to the AT8xC5122/23  
datasheet.

7519A-SCR-04/05



## Product description

AT83C5127 product is high-performance CMOS derivatives of the 80C51 8-bit micro-controllers designed for USB smart card reader applications.

The AT83C5127 is a low pin count of the AT8xC5122 and is proposed in ROM version. The ROM device is only factory programmable.

## Block Diagram

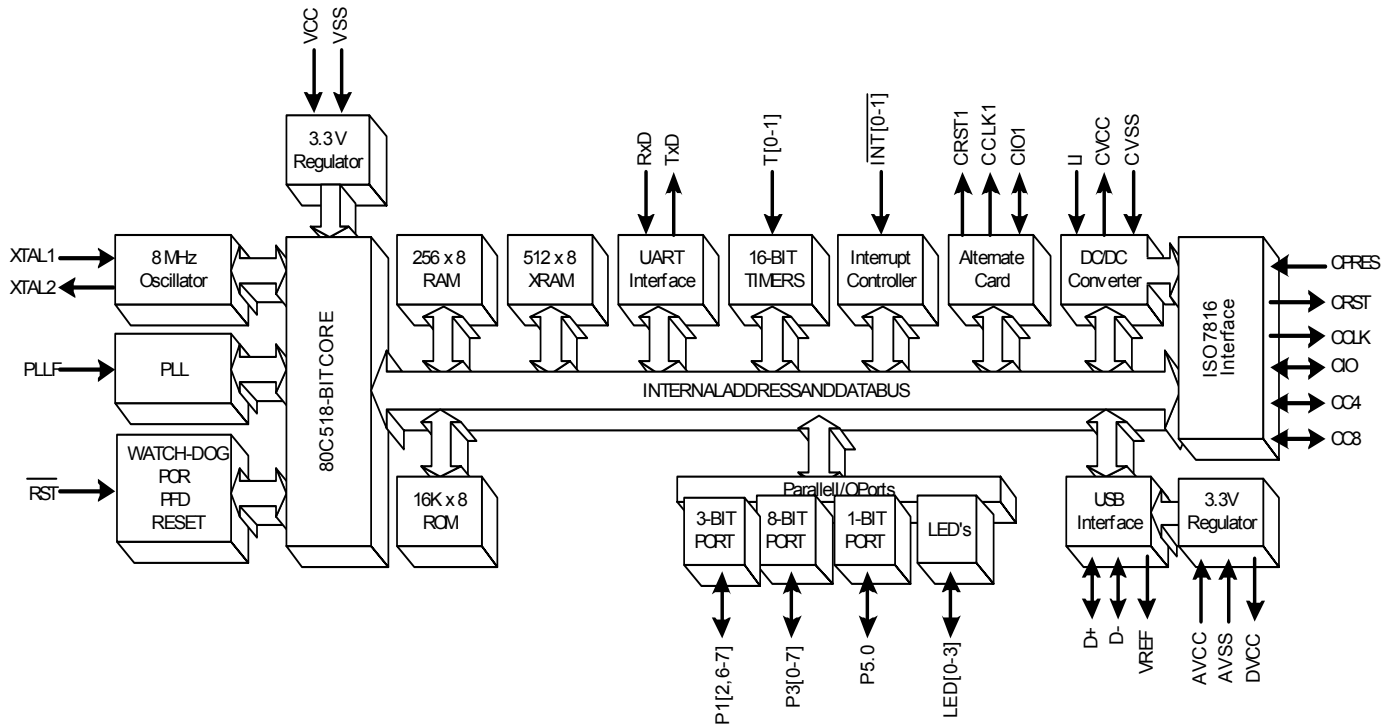

Package Description

Figure 1. VQFP32 Package Pinout

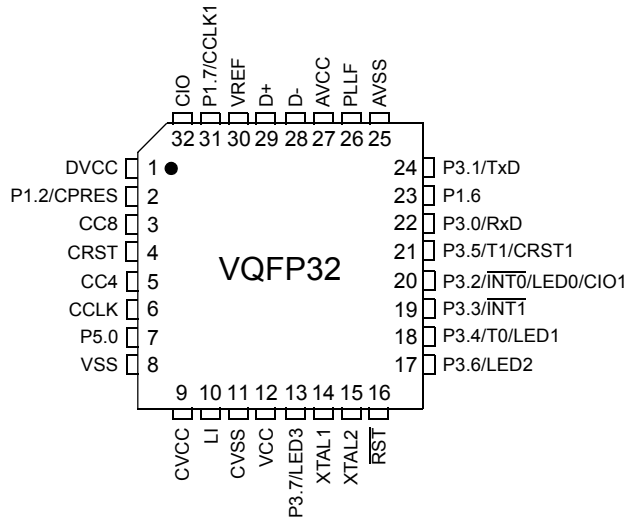
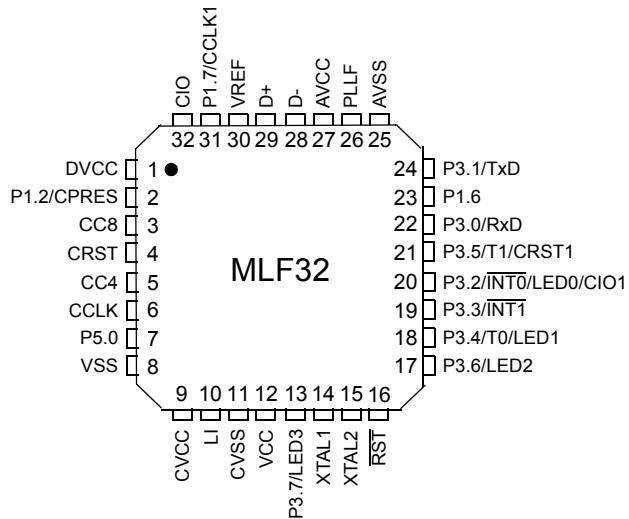

Figure 2. MLF32 Package Pinout



## Pin Description

Table 1. Pin Description

Port	LQFP32	QFN32	Internal Power Supply	ESD	I/O	Reset Level	Alt	Reset Config	Conf 1	Conf 2	Conf 3	Led
CIO	32	32	CVCC	6KV	I/O	0	CIO	Port51	CVCC inactive at reset. ESD tested with a 10µF on CVCC			
CC4	3	3	CVCC	6KV	I/O	0	CC8	Port51	CVCC inactive at reset ESD tested with a 10µF on CVCC			
P1.2	2	2	VCC	2KV	I/O	1	CPRES	Port51	Weak & medium pull-up can be disconnected			
CC4	5	5	CVCC	6KV	I/O	0	CC4	Port51	CVCC inactive at reset ESD tested with a 10µF on CVCC			
CCLK	6	6	CVCC	6KV	O	0	CCLK	Push-pull	CVCC inactive at reset ESD tested with a 10µF on CVCC			
CRST	4	4	CVCC	6KV	O	0	CRST	Push-pull	CVCC inactive at reset ESD tested with a 10µF on CVCC			
P1.6	23	23	VCC	2KV	I/O	1		Port51				
P1.7	31	31	VCC	2KV	I/O	1	CCLK1	Port51				
P3.0	22	22	VCC	2KV	I/O	1	RxD	Port51	Push-pull			
P3.1	24	24	VCC	2KV	I/O	1	TxD	Port51	Push-pull			
P3.2	20	20	VCC	2KV	I/O	1	INT0	Port51				LED0
P3.3	19	19	VCC	2KV	I/O	1	INT1	Port51	Push-pull			
P3.4	18	18	VCC	2KV	I/O	1	T0	Port51	Push-pull			LED1
P3.5	21	21	VCC	2KV	I/O	1	T1	Port51				
P3.6	17	17	VCC	2KV	I/O	1		Port51				LED2
P3.7	13	13	VCC	2KV	I/O	1		Port51				LED3
P5.0	7	7	VCC	2KV	I/O	1		Port51	Push-pull			
$\overline{\text{RST}}$	16	16	VCC		I/O		<b>Reset Input</b> The Port pins are driven to their reset conditions when a voltage lower than $V_{IL}$ is applied, whether or not the oscillator is running. This pin has an internal 10K pull-up resistor which allows the device to be reset by connecting a capacitor between this pin and VSS. Asserting $\overline{\text{RST}}$ when the chip is in Idle mode or Power-Down mode returns the chip to normal operation. The output is active for at least 12 oscillator periods when an internal reset occurs.					

Table 1. Pin Description (Continued)

Port	LQFP32	QFN32	Internal Power Supply	ESD	I/O	Reset Level	Alt	Reset Config	Conf 1	Conf 2	Conf 3	Led
D+	29	29	DVCC		I/O		<b>USB Positive Data Upstream Port</b> This pin requires an external serial resistor of 33Ω and a 1.5 KΩ pull-up to VREF for full speed configuration.					
D-	28	28	DVCC		I/O		<b>USB Negative Data Upstream Port</b> This pin requires an external serial resistor of 33Ω					
VREF	30	30	AVCC		O		<b>USB Voltage Reference: 3.0 &lt; VREF &lt; 3.6 V</b> VREF can be connected to D+ through a 1.5 KΩ resistor. The VREF voltage is controlled by software.					
XTAL1	14	14	VCC		I		<b>Input to the on-chip inverting oscillator amplifier</b> To use the internal oscillator, a crystal or an external oscillator must be connected to this pin.					
XTAL2	15	15	VCC		O		<b>Output of the on-chip inverting oscillator amplifier</b> To use the internal oscillator, a crystal circuit must be connected to this pin. If an external oscillator is used, leave XTAL2 unconnected.					
PLL F	26	26	AVCC		O		<b>PLL Low Pass Filter input</b> Receives the RC network of the PLL low pass filter.					
AVCC	27	27			PWR		<b>Analog Supply Voltage</b> AVCC is used to supply the internal 3.3V analog regulator which supplies the internal USB driver					
VCC	12	12			PWR		<b>Supply Voltage</b> VCC is used to supply the internal 3.3V digital regulator which supplies the PLL, CPU core and internal I/O's					
LI	10	10			PWR		<b>DC/DC Input</b> LI supplies the current for the charge pump of the DC/DC converter. - LI tied directly to VCC : the DC/DC converter must be configured in regulator mode. - LI tied to VCC through an external 10μH coil : the DC/DC converter can be configured either in regulator or in pump mode.					
CVCC	9	9			PWR		<b>Card Supply Voltage</b> CVCC is the output of internal DC/DC converter which supplies the Smart Card Interface. It must be connected to an external decoupling capacitor of 10 μF with the lowest ESR as this parameter influences on the CVCC noise					
DVCC	1	1			PWR		<b>Digital Supply Voltage</b> DVCC is the output of the internal analog 3.3V regulator which supplies the USB driver. This pin must be connected to an external 680nF decoupling capacitor if the USB interface is used.					
CVSS	11	11			GND		<b>DC/DC Ground</b> CVSS is used to sink high shunt currents from the external coil					
VSS	8	8			GND		<b>Digital Ground</b> VSS is used to supply the PLL, buffer ring and the digital core					
AVSS	25	25			GND		<b>Analog Ground</b> AVSS is used to supply the USB driver.					



**Ordering  
Information**

<b>Part Number</b>	<b>Memory Size (bytes)</b>	<b>Supply Voltage (V)</b>	<b>Temperature Range</b>	<b>Max Frequency (MHz)</b>	<b>Package</b>	<b>Packing</b>	<b>Lead free/ RoHS Part Number</b>
AT83C5127xxx-RATIM	16K ROM	4.5 - 5.5	Industrial	48 MHz / X1	LQFP32	Tray	AT83C5127xxx-RATUM
AT83C5127xxx-RARIM	16K ROM	4.5 - 5.5	Industrial	48 MHz / X1	LQFP32	Tape & Reel	AT83C5127xxx-RARUM
AT83C5127xxx-PUTIM	16K ROM	4.5 - 5.5	Industrial	48 MHz / X1	QFN32	Tray	AT83C5127xxx-PUTUM
AT83C5127xxx-PURIM	16K ROM	4.5 - 5.5	Industrial	48 MHz / X1	QFN32	Tape & Reel	AT83C5127xxx-PURUM



# Packaging Information

## LQFP32 Package

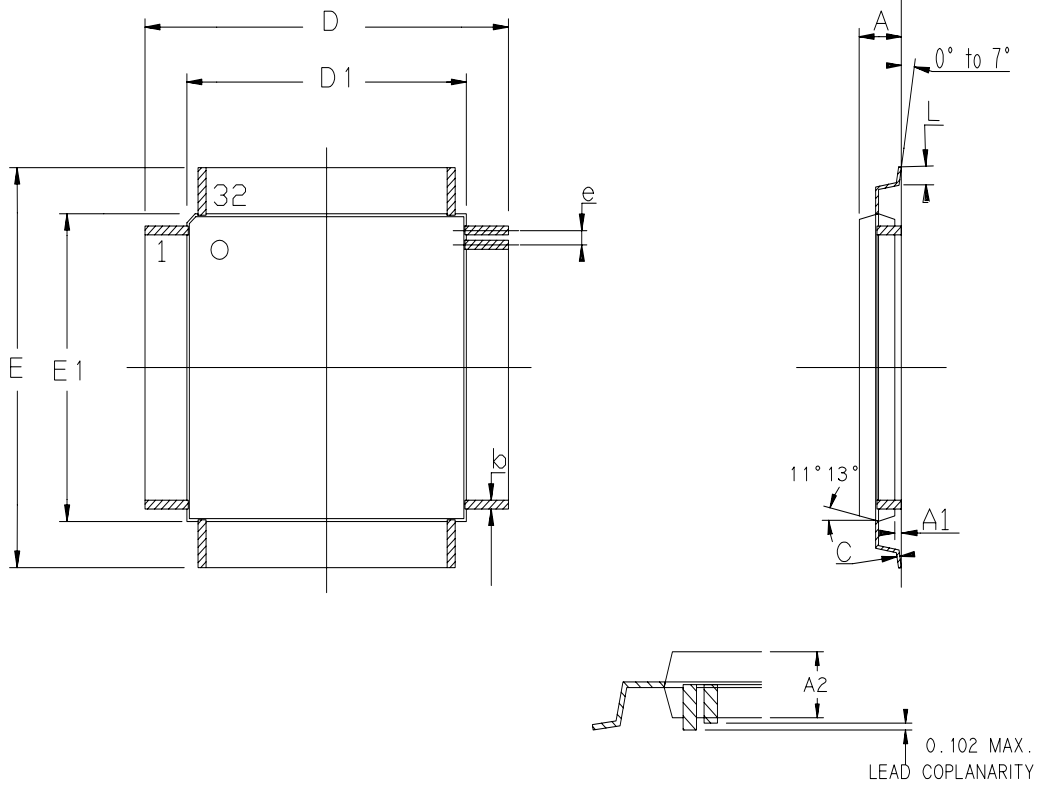

	MM		INCH	
	Min	Max	Min	Max
A	-	1.60	-	.063
A1	0.05	0.15	.002	.006
A2	1.35	1.45	.053	.057
C	0.09	0.20	.004	.008
D	9.00 BSC		.354 BSC	
D1	7.00 BSC		.276 BSC	
E	9.00 BSC		.354 BSC	
E1	7.00 BSC		.276 BSC	
L	0.45	0.75	.018	.030
e	0.80 BSC		.0315 BSC	
b	0.30	0.45	.012	.018

QFN32 Package

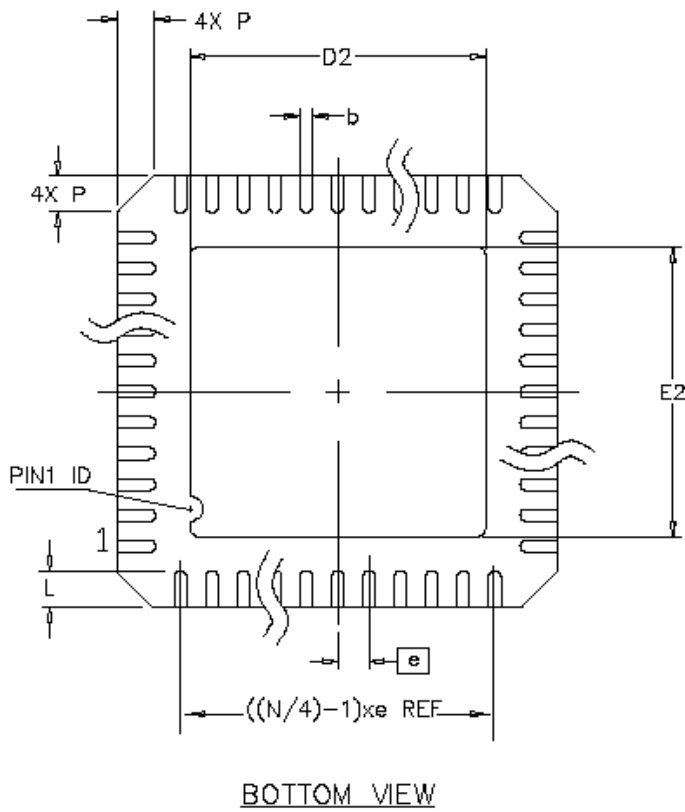
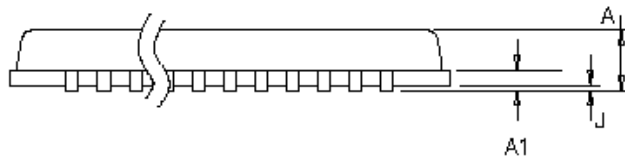
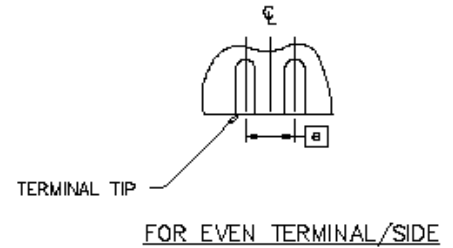
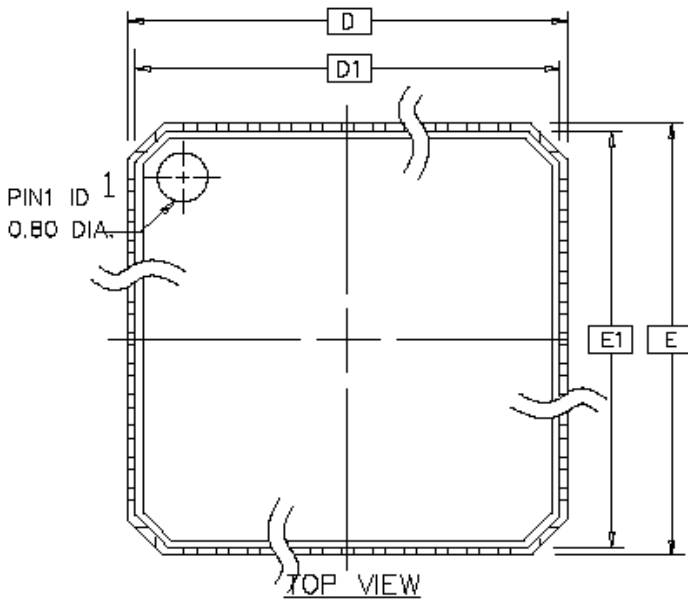

	MM			INCH		
	MIN	NOM	MAX	MIN	NOM	MAX
A	-	0.85	0.90	-	.033	.035
J	0.00	0.01	0.05	.000	.000	.002
A1		0.20	ref		.008	ref
D/E		7.00	BSC		.276	BSC
D1/E1		6.75	BSC		.266	BSC
D2/E2	4.95	5.10	5.25	.195	.201	.207
N	32					
P	0.24	0.42	0.60	.009	.016	.024
e		0.65	BSC		.026	BSC
L	0.50	0.60	0.75	.020	.024	.030
b	0.23	0.28	0.35	.009	.011	.014