

Features

- High Performance, Low Power AVR[®] 8-Bit Microcontroller
- Advanced RISC Architecture
 - 135 Powerful Instructions – Most Single Clock Cycle Execution
 - 32 x 8 General Purpose Working Registers
 - Fully Static Operation
 - Up to 16 MIPS Throughput at 16 MHz
 - On-Chip 2-cycle Multiplier
- Non-volatile Program and Data Memories
 - 16/32K Bytes of In-System Self-Programmable Flash (ATmega16U4/ATmega32U4)
 - 1.25/2.5K Bytes Internal SRAM (ATmega16U4/ATmega32U4)
 - 512Bytes/1K Bytes Internal EEPROM (ATmega16U4/ATmega32U4)
 - Write/Erase Cycles: 10,000 Flash/100,000 EEPROM
 - Data retention: 20 years at 85°C/ 100 years at 25°C⁽¹⁾
 - Optional Boot Code Section with Independent Lock Bits
 - In-System Programming by On-chip Boot Program hardware activated after reset
 - True Read-While-Write Operation
 - All supplied parts are preprogrammed with a default USB bootloader
 - Programming Lock for Software Security
- JTAG (IEEE std. 1149.1 compliant) Interface
 - Boundary-scan Capabilities According to the JTAG Standard
 - Extensive On-chip Debug Support
 - Programming of Flash, EEPROM, Fuses, and Lock Bits through the JTAG Interface
- USB 2.0 Full-speed/Low Speed Device Module with Interrupt on Transfer Completion
 - Complies fully with Universal Serial Bus Specification Rev 2.0
 - Supports data transfer rates up to 12 Mbit/s and 1.5 Mbit/s
 - Endpoint 0 for Control Transfers: up to 64-bytes
 - 6 Programmable Endpoints with IN or Out Directions and with Bulk, Interrupt or Isochronous Transfers
 - Configurable Endpoints size up to 256 bytes in double bank mode
 - Fully independent 832 bytes USB DPRAM for endpoint memory allocation
 - Suspend/Resume Interrupts
 - CPU Reset possible on USB Bus Reset detection
 - 48 MHz from PLL for Full-speed Bus Operation
 - USB Bus Connection/Disconnection on Microcontroller Request
- Peripheral Features
 - On-chip PLL for USB and High Speed Timer: 32 up to 96 MHz operation
 - Two 8-bit Timer/Counters with Separate Prescaler and Compare Mode
 - Two 16-bit Timer/Counter with Separate Prescaler, Compare- and Capture Mode
 - One 10-bit High-Speed Timer/Counter with PLL (64 MHz) and Compare Mode
 - Four 8-bit PWM Channels
 - Four PWM Channels with Programmable Resolution from 2 to 16 Bits
 - Six PWM Channels for High Speed Operation, with Programmable Resolution from 2 to 11 Bits
 - Output Compare Modulator
 - 12-channels, 10-bit ADC (features Differential Channels with Programmable Gain)
 - Programmable Serial USART with Hardware Flow Control
 - Master/Slave SPI Serial Interface



**8-bit AVR[®]
Microcontroller
with
16/32K Bytes of
ISP Flash
and USB
Controller**

**ATmega16U4
ATmega32U4**

Preliminary

- Byte Oriented 2-wire Serial Interface
- Programmable Watchdog Timer with Separate On-chip Oscillator
- On-chip Analog Comparator
- Interrupt and Wake-up on Pin Change (8xPCINT + 5xINT sources)
- On-chip Temperature Sensor (see A/D Converter section)
- Special Microcontroller Features
 - Power-on Reset and Programmable Brown-out Detection
 - Internal 8 MHz Calibrated Oscillator
 - Internal clock prescaler & On-the-fly Clock Switching (Int RC / Ext Osc)
 - External and Internal Interrupt Sources
 - Six Sleep Modes: Idle, ADC Noise Reduction, Power-save, Power-down, Standby, and Extended Standby
- I/O and Packages
 - All I/O combine CMOS outputs and LVTTTL inputs
 - 26 Programmable I/O Lines
 - 44-lead TQFP Package, 10x10mm
 - 44-lead QFN Package, 7x7mm
- Operating Voltages
 - 2.7 - 5.5V
- Operating temperature
 - Industrial (-40°C to +85°C)
- Maximum Frequency
 - 8 MHz at 2.7V - Industrial range
 - 16 MHz at 4.5V - Industrial range

Note: 1. See [“Data Retention” on page 8](#) for details.

1. Pin Configurations

Figure 1-1. Pinout ATmega16U4/ATmega32U4

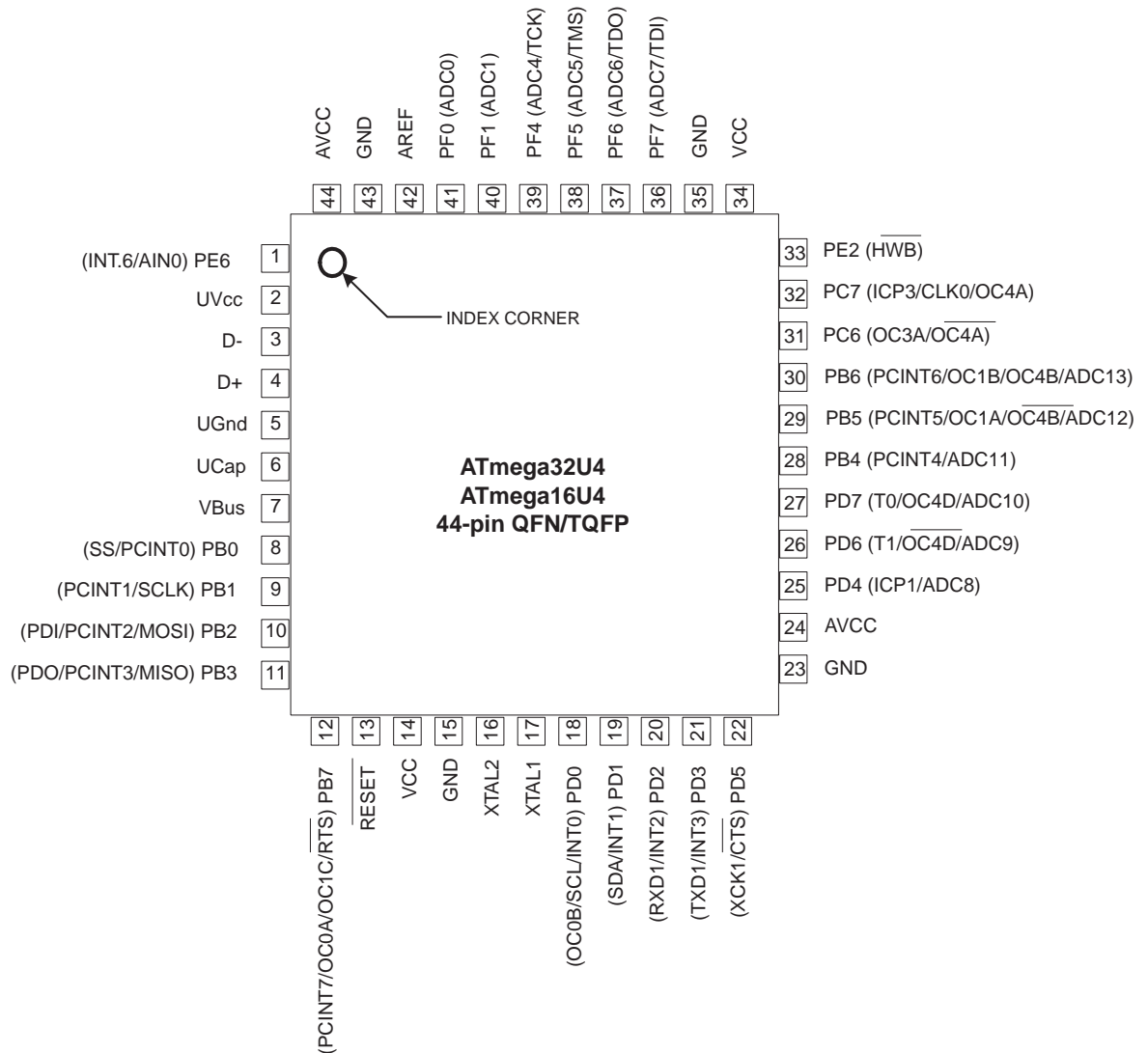

2. Overview

The ATmega16U4/ATmega32U4 is a low-power CMOS 8-bit microcontroller based on the AVR enhanced RISC architecture. By executing powerful instructions in a single clock cycle, the ATmega16U4/ATmega32U4 achieves throughputs approaching 1 MIPS per MHz allowing the system designer to optimize power consumption versus processing speed.

2.1 Block Diagram

Figure 2-1. Block Diagram

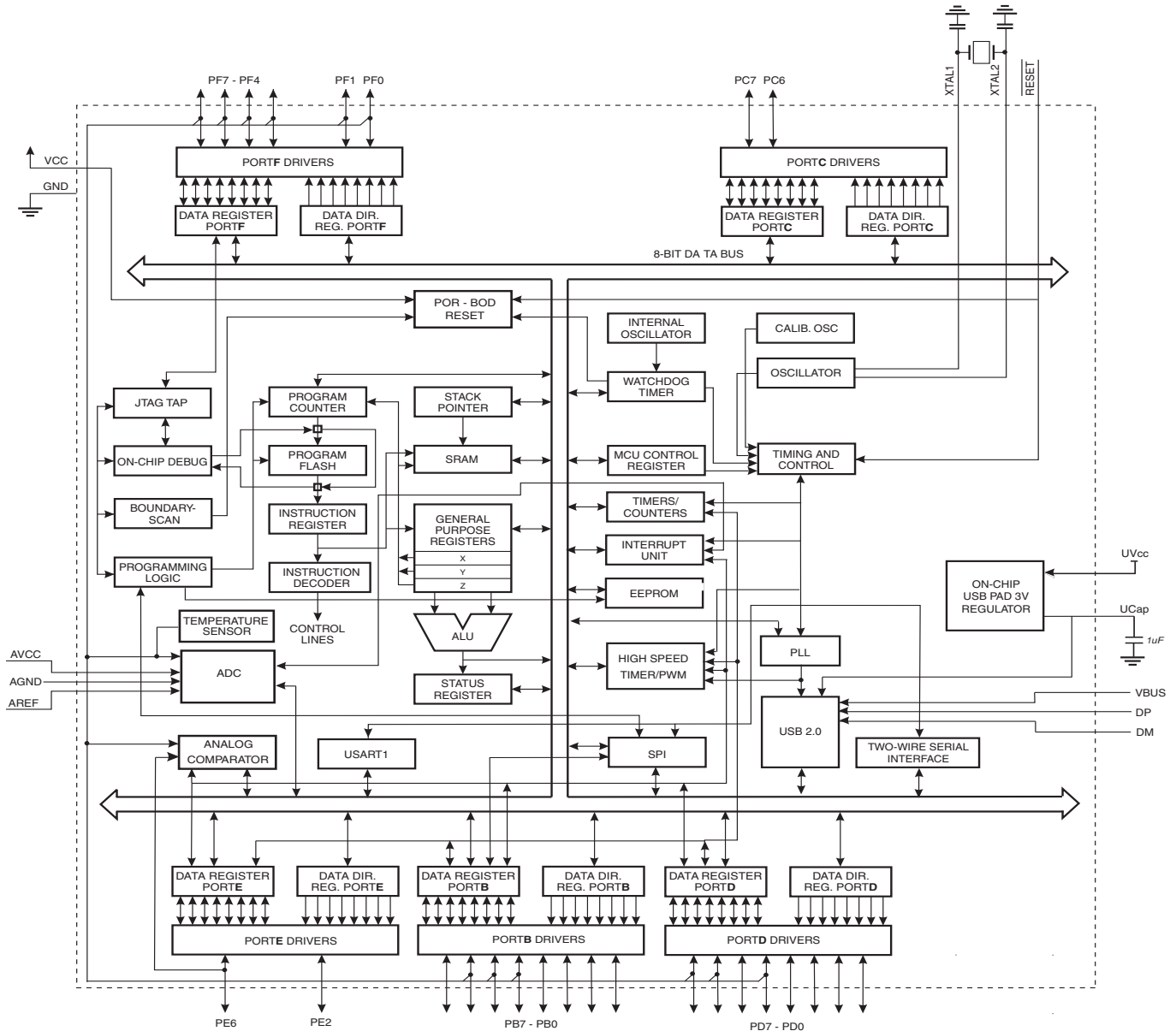

The AVR core combines a rich instruction set with 32 general purpose working registers. All the 32 registers are directly connected to the Arithmetic Logic Unit (ALU), allowing two independent registers to be accessed in one single instruction executed in one clock cycle. The resulting architecture is more code efficient while achieving throughputs up to ten times faster than conventional CISC microcontrollers.

The ATmega16U4/ATmega32U4 provides the following features: 16/32K bytes of In-System Programmable Flash with Read-While-Write capabilities, 512Bytes/1K bytes EEPROM, 1.25/2.5K bytes SRAM, 26 general purpose I/O lines (CMOS outputs and LVTTTL inputs), 32 general purpose working registers, four flexible Timer/Counters with compare modes and PWM, one more high-speed Timer/Counter with compare modes and PLL adjustable source, one USART (including CTS/RTS flow control signals), a byte oriented 2-wire Serial Interface, a 12-

channels 10-bit ADC with optional differential input stage with programmable gain, an on-chip calibrated temperature sensor, a programmable Watchdog Timer with Internal Oscillator, an SPI serial port, IEEE std. 1149.1 compliant JTAG test interface, also used for accessing the On-chip Debug system and programming and six software selectable power saving modes. The Idle mode stops the CPU while allowing the SRAM, Timer/Counters, SPI port, and interrupt system to continue functioning. The Power-down mode saves the register contents but freezes the Oscillator, disabling all other chip functions until the next interrupt or Hardware Reset. The ADC Noise Reduction mode stops the CPU and all I/O modules except ADC, to minimize switching noise during ADC conversions. In Standby mode, the Crystal/Resonator Oscillator is running while the rest of the device is sleeping. This allows very fast start-up combined with low power consumption.

The device is manufactured using ATMEL's high-density nonvolatile memory technology. The On-chip ISP Flash allows the program memory to be reprogrammed in-system through an SPI serial interface, by a conventional nonvolatile memory programmer, or by an On-chip Boot program running on the AVR core. The boot program can use any interface to download the application program in the application Flash memory. Software in the Boot Flash section will continue to run while the Application Flash section is updated, providing true Read-While-Write operation. By combining an 8-bit RISC CPU with In-System Self-Programmable Flash on a monolithic chip, the ATMEL ATmega16U4/ATmega32U4 is a powerful microcontroller that provides a highly flexible and cost effective solution to many embedded control applications.

The ATmega16U4/ATmega32U4 AVR is supported with a full suite of program and system development tools including: C compilers, macro assemblers, program debugger/simulators, in-circuit emulators, and evaluation kits.

2.2 Pin Descriptions

2.2.1 VCC

Digital supply voltage.

2.2.2 GND

Ground.

2.2.3 Port B (PB7..PB0)

Port B is an 8-bit bi-directional I/O port with internal pull-up resistors (selected for each bit). The Port B output buffers have symmetrical drive characteristics with both high sink and source capability. As inputs, Port B pins that are externally pulled low will source current if the pull-up resistors are activated. The Port B pins are tri-stated when a reset condition becomes active, even if the clock is not running.

Port B has better driving capabilities than the other ports.

Port B also serves the functions of various special features of the ATmega16U4/ATmega32U4 as listed on [page 71](#).

2.2.4 Port C (PC7,PC6)

Port C is an 8-bit bi-directional I/O port with internal pull-up resistors (selected for each bit). The Port C output buffers have symmetrical drive characteristics with both high sink and source capability. As inputs, Port C pins that are externally pulled low will source current if the pull-up resistors are activated. The Port C pins are tri-stated when a reset condition becomes active, even if the clock is not running.

Only bits 6 and 7 are present on the product pinout.

Port C also serves the functions of special features of the ATmega16U4/ATmega32U4 as listed on [page 74](#).

2.2.5 Port D (PD7..PD0)

Port D is an 8-bit bi-directional I/O port with internal pull-up resistors (selected for each bit). The Port D output buffers have symmetrical drive characteristics with both high sink and source capability. As inputs, Port D pins that are externally pulled low will source current if the pull-up resistors are activated. The Port D pins are tri-stated when a reset condition becomes active, even if the clock is not running.

Port D also serves the functions of various special features of the ATmega16U4/ATmega32U4 as listed on [page 76](#).

2.2.6 Port E (PE6,PE2)

Port E is an 8-bit bi-directional I/O port with internal pull-up resistors (selected for each bit). The Port E output buffers have symmetrical drive characteristics with both high sink and source capability. As inputs, Port E pins that are externally pulled low will source current if the pull-up resistors are activated. The Port E pins are tri-stated when a reset condition becomes active, even if the clock is not running.

Only bits 2 and 6 are present on the product pinout.

Port E also serves the functions of various special features of the ATmega16U4/ATmega32U4 as listed on [page 79](#).

2.2.7 Port F (PF7..PF4, PF1,PF0)

Port F serves as analog inputs to the A/D Converter.

Port F also serves as an 8-bit bi-directional I/O port, if the A/D Converter channels are not used. Port pins can provide internal pull-up resistors (selected for each bit). The Port F output buffers have symmetrical drive characteristics with both high sink and source capability. As inputs, Port F pins that are externally pulled low will source current if the pull-up resistors are activated. The Port F pins are tri-stated when a reset condition becomes active, even if the clock is not running.

Bits 2 and 3 are not present on the product pinout.

Port F also serves the functions of the JTAG interface. If the JTAG interface is enabled, the pull-up resistors on pins PF7(TDI), PF5(TMS), and PF4(TCK) will be activated even if a reset occurs.

2.2.8 D-

USB Full speed / Low Speed Negative Data Upstream Port. Should be connected to the USB D- connector pin with a serial 22 Ohms resistor.

2.2.9 D+

USB Full speed / Low Speed Positive Data Upstream Port. Should be connected to the USB D+ connector pin with a serial 22 Ohms resistor.

2.2.10 UGND

USB Pads Ground.

- 2.2.11 UVCC**
USB Pads Internal Regulator Input supply voltage.
- 2.2.12 UCAP**
USB Pads Internal Regulator Output supply voltage. Should be connected to an external capacitor (1 μ F).
- 2.2.13 VBUS**
USB VBUS monitor input.
- 2.2.14 $\overline{\text{RESET}}$**
Reset input. A low level on this pin for longer than the minimum pulse length will generate a reset, even if the clock is not running. The minimum pulse length is given in [Table 8-1 on page 49](#). Shorter pulses are not guaranteed to generate a reset.
- 2.2.15 XTAL1**
Input to the inverting Oscillator amplifier and input to the internal clock operating circuit.
- 2.2.16 XTAL2**
Output from the inverting Oscillator amplifier.
- 2.2.17 AVCC**
AVCC is the supply voltage pin (input) for all the A/D Converter channels. If the ADC is not used, it should be externally connected to V_{CC} . If the ADC is used, it should be connected to V_{CC} through a low-pass filter.
- 2.2.18 AREF**
This is the analog reference pin (input) for the A/D Converter.

3. About

3.1 Disclaimer

Typical values contained in this datasheet are based on simulations and characterization of other AVR microcontrollers manufactured on the same process technology. Min and Max values will be available after the device is characterized.

3.2 Resources

A comprehensive set of development tools, application notes and datasheets are available for download on <http://www.atmel.com/avr>.

3.3 Code Examples

This documentation contains simple code examples that briefly show how to use various parts of the device. Be aware that not all C compiler vendors include bit definitions in the header files and interrupt handling in C is compiler dependent. Please confirm with the C compiler documentation for more details.

These code examples assume that the part specific header file is included before compilation. For I/O registers located in extended I/O map, "IN", "OUT", "SBIS", "SBIC", "CBI", and "SBI" instructions must be replaced with instructions that allow access to extended I/O. Typically "LDS" and "STS" combined with "SBRS", "SBRC", "SBR", and "CBR".

3.4 Data Retention

Reliability Qualification results show that the projected data retention failure rate is much less than 1 PPM over 20 years at 85°C or 100 years at 25°C.

4. Register Summary

Address	Name	Bit 7	Bit 6	Bit 5	Bit 4	Bit 3	Bit 2	Bit 1	Bit 0	Page		
(0xFF)	Reserved	-	-	-	-	-	-	-	-			
(0xFE)	Reserved	-	-	-	-	-	-	-	-			
(0xFD)	Reserved	-	-	-	-	-	-	-	-			
(0xFC)	Reserved	-	-	-	-	-	-	-	-			
(0xFB)	Reserved	-	-	-	-	-	-	-	-			
(0xFA)	Reserved	-	-	-	-	-	-	-	-			
(0xF9)	Reserved	-	-	-	-	-	-	-	-			
(0xF8)	Reserved	-	-	-	-	-	-	-	-			
(0xF7)	Reserved	-	-	-	-	-	-	-	-			
(0xF6)	Reserved	-	-	-	-	-	-	-	-			
(0xF5)	Reserved	-	-	-	-	-	-	-	-			
(0xF4)	UEINT	-	EPINT6:0						-	-		
(0xF3)	UEBCHX	-	-	-	-	-	BYCT10:8					
(0xF2)	UEBCLX	BYCT7:0										
(0xF1)	UEDATX	DAT7:0										
(0xF0)	UEIENX	FLERRE	NAKINE	-	NAKOUTE	RXSTPE	RXOUTE	STALLEDE	TXINE			
(0xEF)	UESTA1X	-	-	-	-	-	CTRLDIR	CURRBK1:0				
(0xEE)	UESTA0X	CFGOK	OVERFI	UNDERFI	-	DTSEQ1:0		NBUSYBK1:0				
(0xED)	UECFG1X	EPSIZE2:0		EPBK1:0		ALLOC	-	-	-			
(0xEC)	UECFG0X	EPTYPE1:0		-	-	-	-	-	EPDIR			
(0xEB)	UECONX	-	-	STALLRQ	STALLRQC	RSTDT	-	-	EPEN			
(0xEA)	UERST	EPRST6:0										
(0xE9)	UENUM	-	-	-	-	-	EPNUM2:0					
(0xE8)	UEINTX	FIFOCON	NAKINI	RWAL	NAKOUTI	RXSTPI	RXOUTI	STALLEDI	TXINI			
(0xE7)	Reserved	-	-	-	-	-	-	-	-			
(0xE6)	UDMFN	-	-	-	FNCERR	-	-	-	-			
(0xE5)	UDFNUMH	-	-	-	-	-	FNUM10:8					
(0xE4)	UDFNUML	FNUM7:0										
(0xE3)	UDADDR	ADDEN	UADD6:0							-	-	
(0xE2)	UDIEN	-	UPRSME	EORSME	WAKEUPE	EORSTE	SOFE	MSOFE	SUSPE			
(0xE1)	UDINT	-	UPRSMI	EORSMI	WAKEUPI	EORSTI	SOFI	MSOFI	SUSPI			
(0xE0)	UDCON	-	-	-	-	RSTCPU	LSM	RMWKUP	DETACH			
(0xDF)	Reserved	-	-	-	-	-	-	-	-			
(0xDE)	Reserved	-	-	-	-	-	-	-	-			
(0xDD)	Reserved	-	-	-	-	-	-	-	-			
(0xDC)	Reserved	-	-	-	-	-	-	-	-			
(0xDB)	Reserved	-	-	-	-	-	-	-	-			
(0xDA)	USBINT	-	-	-	-	-	-	-	VBUSTI			
(0xD9)	USBSTA	-	-	-	-	-	-	ID	VBUS			
(0xD8)	USBCON	USBE	-	FRZCLK	OTGPADE	-	-	-	VBUSTE			
(0xD7)	UHWCON	-	-	-	-	-	-	-	UVREGE			
(0xD6)	Reserved	-	-	-	-	-	-	-	-			
(0xD5)	Reserved	-	-	-	-	-	-	-	-			
(0xD4)	DT4	DT4H3	DT4H2	DT4H1	DT4H0	DT4L3	DT4L2	DT4L1	DT4L0			
(0xD3)	Reserved	-	-	-	-	-	-	-	-			
(0xD2)	OCR4D	Timer/Counter4 - Output Compare Register D										
(0xD1)	OCR4C	Timer/Counter4 - Output Compare Register C										
(0xD0)	OCR4B	Timer/Counter4 - Output Compare Register B										
(0xCF)	OCR4A	Timer/Counter4 - Output Compare Register A										
(0xCE)	UDR1	USART1 I/O Data Register										
(0xCD)	UBRR1H	-	-	-	-	USART1 Baud Rate Register High Byte						
(0xCC)	UBRR1L	USART1 Baud Rate Register Low Byte										
(0xCB)	Reserved	-	-	-	-	-	-	-	-			
(0xCA)	UCSR1C	UMSEL11	UMSEL10	UPM11	UPM10	USBS1	UCSZ11	UCSZ10	UCPOL1			
(0xC9)	UCSR1B	RXCIE1	TXCIE1	UDRIE1	RXEN1	TXEN1	UCSZ12	RXB81	TXB81			
(0xC8)	UCSR1A	RXC1	TXC1	UDRE1	FE1	DOR1	PE1	U2X1	MPCM1			
(0xC7)	CLKSTA	-	-	-	-	-	-	RCON	EXTON			
(0xC6)	CLKSEL1	RCCKSEL3	RCCKSEL2	RCCKSEL1	RCCKSEL0	EXCKSEL3	EXCKSEL2	EXCKSEL1	EXCKSEL0			
(0xC5)	CLKSEL0	RCSUT1	RCSUT0	EXSUT1	EXSUT0	RCE	EXTE	-	CLKS			
(0xC4)	TCCR4E	TLOCK4	ENHC4	OC4OE5	OC4OE4	OC4OE3	OC4OE2	OC4OE1	OC4OE0			
(0xC3)	TCCR4D	FPIE4	FPEN4	FPNC4	FPES4	FPAC4	FPF4	WGM41	WGM40			
(0xC2)	TCCR4C	COM4A1S	COM4A0S	COM4B1S	COM4B0S	COM4D1S	COM4D0S	FOC4D	PWM4D			
(0xC1)	TCCR4B	PWM4X	PSR4	DTPS41	DTPS40	CS43	CS42	CS41	CS40			
(0xC0)	TCCR4A	COM4A1	COM4A0	COM4B1	COM4B0	FOC4A	FOC4B	PWM4A	PWM4B			
(0xBF)	TC4H	-	-	-	-	-	Timer/Counter4 High Byte					



Address	Name	Bit 7	Bit 6	Bit 5	Bit 4	Bit 3	Bit 2	Bit 1	Bit 0	Page
(0xBE)	TCNT4	Timer/Counter4 - Counter Register Low Byte								
(0xBD)	TWAMR	TWAM6	TWAM5	TWAM4	TWAM3	TWAM2	TWAM1	TWAM0	-	
(0xBC)	TWCR	TWINT	TWEA	TWSTA	TWSTO	TWWC	TWEN	-	TWIE	
(0xBB)	TWDR	2-wire Serial Interface Data Register								
(0xBA)	TWAR	TWA6	TWA5	TWA4	TWA3	TWA2	TWA1	TWA0	TWGCE	
(0xB9)	TWSR	TWS7	TWS6	TWS5	TWS4	TWS3	-	TWPS1	TWPS0	
(0xB8)	TWBR	2-wire Serial Interface Bit Rate Register								
(0xB7)	Reserved	-	-	-	-	-	-	-	-	
(0xB6)	Reserved	-	-	-	-	-	-	-	-	
(0xB5)	Reserved	-	-	-	-	-	-	-	-	
(0xB4)	Reserved	-	-	-	-	-	-	-	-	
(0xB3)	Reserved	-	-	-	-	-	-	-	-	
(0xB2)	Reserved	-	-	-	-	-	-	-	-	
(0xB1)	Reserved	-	-	-	-	-	-	-	-	
(0xB0)	Reserved	-	-	-	-	-	-	-	-	
(0xAF)	Reserved	-	-	-	-	-	-	-	-	
(0xAE)	Reserved	-	-	-	-	-	-	-	-	
(0xAD)	Reserved	-	-	-	-	-	-	-	-	
(0xAC)	Reserved	-	-	-	-	-	-	-	-	
(0xAB)	Reserved	-	-	-	-	-	-	-	-	
(0xAA)	Reserved	-	-	-	-	-	-	-	-	
(0xA9)	Reserved	-	-	-	-	-	-	-	-	
(0xA8)	Reserved	-	-	-	-	-	-	-	-	
(0xA7)	Reserved	-	-	-	-	-	-	-	-	
(0xA6)	Reserved	-	-	-	-	-	-	-	-	
(0xA5)	Reserved	-	-	-	-	-	-	-	-	
(0xA4)	Reserved	-	-	-	-	-	-	-	-	
(0xA3)	Reserved	-	-	-	-	-	-	-	-	
(0xA2)	Reserved	-	-	-	-	-	-	-	-	
(0xA1)	Reserved	-	-	-	-	-	-	-	-	
(0xA0)	Reserved	-	-	-	-	-	-	-	-	
(0x9F)	Reserved	-	-	-	-	-	-	-	-	
(0x9E)	Reserved	-	-	-	-	-	-	-	-	
(0x9D)	OCR3CH	Timer/Counter3 - Output Compare Register C High Byte								
(0x9C)	OCR3CL	Timer/Counter3 - Output Compare Register C Low Byte								
(0x9B)	OCR3BH	Timer/Counter3 - Output Compare Register B High Byte								
(0x9A)	OCR3BL	Timer/Counter3 - Output Compare Register B Low Byte								
(0x99)	OCR3AH	Timer/Counter3 - Output Compare Register A High Byte								
(0x98)	OCR3AL	Timer/Counter3 - Output Compare Register A Low Byte								
(0x97)	ICR3H	Timer/Counter3 - Input Capture Register High Byte								
(0x96)	ICR3L	Timer/Counter3 - Input Capture Register Low Byte								
(0x95)	TCNT3H	Timer/Counter3 - Counter Register High Byte								
(0x94)	TCNT3L	Timer/Counter3 - Counter Register Low Byte								
(0x93)	Reserved	-	-	-	-	-	-	-	-	
(0x92)	TCCR3C	FOC3A	-	-	-	-	-	-	-	
(0x91)	TCCR3B	ICNC3	ICES3	-	WGM33	WGM32	CS32	CS31	CS30	
(0x90)	TCCR3A	COM3A1	COM3A0	COM3B1	COM3B0	COM3C1	COM3C0	WGM31	WGM30	
(0x8F)	Reserved	-	-	-	-	-	-	-	-	
(0x8E)	Reserved	-	-	-	-	-	-	-	-	
(0x8D)	OCR1CH	Timer/Counter1 - Output Compare Register C High Byte								
(0x8C)	OCR1CL	Timer/Counter1 - Output Compare Register C Low Byte								
(0x8B)	OCR1BH	Timer/Counter1 - Output Compare Register B High Byte								
(0x8A)	OCR1BL	Timer/Counter1 - Output Compare Register B Low Byte								
(0x89)	OCR1AH	Timer/Counter1 - Output Compare Register A High Byte								
(0x88)	OCR1AL	Timer/Counter1 - Output Compare Register A Low Byte								
(0x87)	ICR1H	Timer/Counter1 - Input Capture Register High Byte								
(0x86)	ICR1L	Timer/Counter1 - Input Capture Register Low Byte								
(0x85)	TCNT1H	Timer/Counter1 - Counter Register High Byte								
(0x84)	TCNT1L	Timer/Counter1 - Counter Register Low Byte								
(0x83)	Reserved	-	-	-	-	-	-	-	-	
(0x82)	TCCR1C	FOC1A	FOC1B	FOC1C	-	-	-	-	-	
(0x81)	TCCR1B	ICNC1	ICES1	-	WGM13	WGM12	CS12	CS11	CS10	
(0x80)	TCCR1A	COM1A1	COM1A0	COM1B1	COM1B0	COM1C1	COM1C0	WGM11	WGM10	
(0x7F)	DIDR1	-	-	-	-	-	-	-	AIN0D	
(0x7E)	DIDR0	ADC7D	ADC6D	ADC5D	ADC4D	-	-	ADC1D	ADC0D	
(0x7D)	DIDR2	-	-	ADC13D	ADC12D	ADC11D	ADC10D	ADC9D	ADC8D	

Address	Name	Bit 7	Bit 6	Bit 5	Bit 4	Bit 3	Bit 2	Bit 1	Bit 0	Page
(0x7C)	ADMUX	REFS1	REFS0	ADLAR	MUX4	MUX3	MUX2	MUX1	MUX0	
(0x7B)	ADCSRB	ADHSM	ACME	MUX5	-	ADTS3	ADTS2	ADTS1	ADTS0	
(0x7A)	ADCSRA	ADEN	ADSC	ADATE	ADIF	ADIE	ADPS2	ADPS1	ADPS0	
(0x79)	ADCH	ADC Data Register High byte								
(0x78)	ADCL	ADC Data Register Low byte								
(0x77)	Reserved	-	-	-	-	-	-	-	-	
(0x76)	Reserved	-	-	-	-	-	-	-	-	
(0x75)	Reserved	-	-	-	-	-	-	-	-	
(0x74)	Reserved	-	-	-	-	-	-	-	-	
(0x73)	Reserved	-	-	-	-	-	-	-	-	
(0x72)	TIMSK4	OCIE4D	OCIE4A	OCIE4B	-	-	TOIE4	-	-	
(0x71)	TIMSK3	-	-	ICIE3	-	OCIE3C	OCIE3B	OCIE3A	TOIE3	
(0x70)	Reserved	-	-	-	-	-	-	-	-	
(0x6F)	TIMSK1	-	-	ICIE1	-	OCIE1C	OCIE1B	OCIE1A	TOIE1	
(0x6E)	TIMSK0	-	-	-	-	-	OCIE0B	OCIE0A	TOIE0	
(0x6D)	Reserved	-	-	-	-	-	-	-	-	
(0x6C)	Reserved	-	-	-	-	-	-	-	-	
(0x6B)	PCMSK0	PCINT7	PCINT6	PCINT5	PCINT4	PCINT3	PCINT2	PCINT1	PCINT0	
(0x6A)	EICRB	-	-	ISC61	ISC60	-	-	-	-	
(0x69)	EICRA	ISC31	ISC30	ISC21	ISC20	ISC11	ISC10	ISC01	ISC00	
(0x68)	PCICR	-	-	-	-	-	-	-	PCIE0	
(0x67)	RCCTRL	-	-	-	-	-	-	-	RCFREQ	
(0x66)	OSCCAL	RC Oscillator Calibration Register								
(0x65)	PRR1	PRUSB	-	-	PRTIM4	PRTIM3	-	-	PRUSART1	
(0x64)	PRR0	PRTWI	-	PRTIM0	-	PRTIM1	PRSPI	-	PRADC	
(0x63)	Reserved	-	-	-	-	-	-	-	-	
(0x62)	Reserved	-	-	-	-	-	-	-	-	
(0x61)	CLKPR	CLKPCE	-	-	-	CLKPS3	CLKPS2	CLKPS1	CLKPS0	
(0x60)	WDTCR	WDIF	WDIE	WDP3	WDCE	WDE	WDP2	WDP1	WDP0	
0x3F (0x5F)	SREG	I	T	H	S	V	N	Z	C	
0x3E (0x5E)	SPH	SP15	SP14	SP13	SP12	SP11	SP10	SP9	SP8	
0x3D (0x5D)	SPL	SP7	SP6	SP5	SP4	SP3	SP2	SP1	SP0	
0x3C (0x5C)	Reserved	-	-	-	-	-	-	-	-	
0x3B (0x5B)	RAMPZ	-	-	-	-	-	-	RAMPZ1	RAMPZ0	
0x3A (0x5A)	Reserved	-	-	-	-	-	-	-	-	
0x39 (0x59)	Reserved	-	-	-	-	-	-	-	-	
0x38 (0x58)	Reserved	-	-	-	-	-	-	-	-	
0x37 (0x57)	SPMCSR	SPMIE	RWWSB	SIGRD	RWWSRE	BLBSET	PGWRT	PGERS	SPMEN	
0x36 (0x56)	Reserved	-	-	-	-	-	-	-	-	
0x35 (0x55)	MCUCR	JTD	-	-	PUD	-	-	IVSEL	IVCE	
0x34 (0x54)	MCUSR	-	-	USBRF	JTRF	WDRF	BORF	EXTRF	PORF	
0x33 (0x53)	SMCR	-	-	-	-	SM2	SM1	SM0	SE	
0x32 (0x52)	PLLFREQ	PINMUX	PLLUSB	PLLTM1	PLLTM0	PDIV3	PDIV2	PDIV1	PDIV0	
0x31 (0x51)	OCDR/ MONDR	OCDR7	OCDR6	OCDR5	OCDR4	OCDR3	OCDR2	OCDR1	OCDR0	
0x30 (0x50)	ACSR	ACD	ACBG	ACO	ACI	ACIE	ACIC	ACIS1	ACIS0	
0x2F (0x4F)	Reserved	-	-	-	-	-	-	-	-	
0x2E (0x4E)	SPDR	SPI Data Register								
0x2D (0x4D)	SPSR	SPIF	WCOL	-	-	-	-	-	SPI2X	
0x2C (0x4C)	SPCR	SPIE	SPE	DORD	MSTR	CPOL	CPHA	SPR1	SPR0	
0x2B (0x4B)	GPIOR2	General Purpose I/O Register 2								
0x2A (0x4A)	GPIOR1	General Purpose I/O Register 1								
0x29 (0x49)	PLLCSR	-	-	-	PINDIV	-	-	PLLE	PLOCK	
0x28 (0x48)	OCR0B	Timer/Counter0 Output Compare Register B								
0x27 (0x47)	OCR0A	Timer/Counter0 Output Compare Register A								
0x26 (0x46)	TCNT0	Timer/Counter0 (8 Bit)								
0x25 (0x45)	TCCR0B	FOC0A	FOC0B	-	-	WGM02	CS02	CS01	CS00	
0x24 (0x44)	TCCR0A	COM0A1	COM0A0	COM0B1	COM0B0	-	-	WGM01	WGM00	
0x23 (0x43)	GTCCR	TSM	-	-	-	-	-	PSRASY	PSRSYNC	
0x22 (0x42)	EEARH	-	-	-	-	EEPROM Address Register High Byte				
0x21 (0x41)	EEARL	EEPROM Address Register Low Byte								
0x20 (0x40)	EEDR	EEPROM Data Register								
0x1F (0x3F)	EECR	-	-	EEMP1	EEMP0	EERIE	EEMPE	EEPE	EERE	
0x1E (0x3E)	GPIOR0	General Purpose I/O Register 0								
0x1D (0x3D)	EIMSK	-	INT6	-	-	INT3	INT2	INT1	INT0	
0x1C (0x3C)	EIFR	-	INTF6	-	-	INTF3	INTF2	INTF1	INTF0	

Address	Name	Bit 7	Bit 6	Bit 5	Bit 4	Bit 3	Bit 2	Bit 1	Bit 0	Page
0x1B (0x3B)	PCIFR	-	-	-	-	-	-	-	PCIF0	
0x1A (0x3A)	Reserved	-	-	-	-	-	-	-	-	
0x19 (0x39)	TIFR4	OCF4D	OCF4A	OCF4B	-	-	TOV4	-	-	
0x18 (0x38)	TIFR3	-	-	ICF3	-	OCF3C	OCF3B	OCF3A	TOV3	
0x17 (0x37)	Reserved	-	-	-	-	-	-	-	-	
0x16 (0x36)	TIFR1	-	-	ICF1	-	OCF1C	OCF1B	OCF1A	TOV1	
0x15 (0x35)	TIFR0	-	-	-	-	-	OCF0B	OCF0A	TOV0	
0x14 (0x34)	Reserved	-	-	-	-	-	-	-	-	
0x13 (0x33)	Reserved	-	-	-	-	-	-	-	-	
0x12 (0x32)	Reserved	-	-	-	-	-	-	-	-	
0x11 (0x31)	PORTF	PORTF7	PORTF6	PORTF5	PORTF4	-	-	PORTF1	PORTF0	
0x10 (0x30)	DDRF	DDF7	DDF6	DDF5	DDF4	-	-	DDF1	DDF0	
0x0F (0x2F)	PINF	PINF7	PINF6	PINF5	PINF4	-	-	PINF1	PINF0	
0x0E (0x2E)	PORTE	-	PORTE6	-	-	-	PORTE2	-	-	
0x0D (0x2D)	DDRE	-	DDE6	-	-	-	DDE2	-	-	
0x0C (0x2C)	PINE	-	PINE6	-	-	-	PINE2	-	-	
0x0B (0x2B)	PORTD	PORTD7	PORTD6	PORTD5	PORTD4	PORTD3	PORTD2	PORTD1	PORTD0	
0x0A (0x2A)	DDR	DDD7	DDD6	DDD5	DDD4	DDD3	DDD2	DDD1	DDD0	
0x09 (0x29)	PIND	PIND7	PIND6	PIND5	PIND4	PIND3	PIND2	PIND1	PIND0	
0x08 (0x28)	PORTC	PORTC7	PORTC6	-	-	-	-	-	-	
0x07 (0x27)	DDRC	DDC7	DDC6	-	-	-	-	-	-	
0x06 (0x26)	PINC	PINC7	PINC6	-	-	-	-	-	-	
0x05 (0x25)	PORTB	PORTB7	PORTB6	PORTB5	PORTB4	PORTB3	PORTB2	PORTB1	PORTB0	
0x04 (0x24)	DDRB	DDB7	DDB6	DDB5	DDB4	DDB3	DDB2	DDB1	DDB0	
0x03 (0x23)	PINB	PINB7	PINB6	PINB5	PINB4	PINB3	PINB2	PINB1	PINB0	
0x02 (0x22)	Reserved	-	-	-	-	-	-	-	-	
0x01 (0x21)	Reserved	-	-	-	-	-	-	-	-	
0x00 (0x20)	Reserved	-	-	-	-	-	-	-	-	

- Note:
1. For compatibility with future devices, reserved bits should be written to zero if accessed. Reserved I/O memory addresses should never be written.
 2. I/O registers within the address range \$00 - \$1F are directly bit-accessible using the SBI and CBI instructions. In these registers, the value of single bits can be checked by using the SBIS and SBIC instructions.
 3. Some of the status flags are cleared by writing a logical one to them. Note that the CBI and SBI instructions will operate on all bits in the I/O register, writing a one back into any flag read as set, thus clearing the flag. The CBI and SBI instructions work with registers 0x00 to 0x1F only.
 4. When using the I/O specific commands IN and OUT, the I/O addresses \$00 - \$3F must be used. When addressing I/O registers as data space using LD and ST instructions, \$20 must be added to these addresses. The ATmega16U4/ATmega32U4 is a complex microcontroller with more peripheral units than can be supported within the 64 location reserved in Opcode for the IN and OUT instructions. For the Extended I/O space from \$60 - \$1FF in SRAM, only the ST/STS/STD and LD/LDS/LDD instructions can be used.



5. Instruction Set Summary

Mnemonics	Operands	Description	Operation	Flags	#Clocks
ARITHMETIC AND LOGIC INSTRUCTIONS					
ADD	Rd, Rr	Add two Registers	$Rd \leftarrow Rd + Rr$	Z,C,N,V,H	1
ADC	Rd, Rr	Add with Carry two Registers	$Rd \leftarrow Rd + Rr + C$	Z,C,N,V,H	1
ADIW	RdI, K	Add Immediate to Word	$Rdh:Rdl \leftarrow Rdh:Rdl + K$	Z,C,N,V,S	2
SUB	Rd, Rr	Subtract two Registers	$Rd \leftarrow Rd - Rr$	Z,C,N,V,H	1
SUBI	Rd, K	Subtract Constant from Register	$Rd \leftarrow Rd - K$	Z,C,N,V,H	1
SBC	Rd, Rr	Subtract with Carry two Registers	$Rd \leftarrow Rd - Rr - C$	Z,C,N,V,H	1
SBCI	Rd, K	Subtract with Carry Constant from Reg.	$Rd \leftarrow Rd - K - C$	Z,C,N,V,H	1
SBIW	RdI, K	Subtract Immediate from Word	$Rdh:Rdl \leftarrow Rdh:Rdl - K$	Z,C,N,V,S	2
AND	Rd, Rr	Logical AND Registers	$Rd \leftarrow Rd \cdot Rr$	Z,N,V	1
ANDI	Rd, K	Logical AND Register and Constant	$Rd \leftarrow Rd \cdot K$	Z,N,V	1
OR	Rd, Rr	Logical OR Registers	$Rd \leftarrow Rd \vee Rr$	Z,N,V	1
ORI	Rd, K	Logical OR Register and Constant	$Rd \leftarrow Rd \vee K$	Z,N,V	1
EOR	Rd, Rr	Exclusive OR Registers	$Rd \leftarrow Rd \oplus Rr$	Z,N,V	1
COM	Rd	One's Complement	$Rd \leftarrow 0xFF - Rd$	Z,C,N,V	1
NEG	Rd	Two's Complement	$Rd \leftarrow 0x00 - Rd$	Z,C,N,V,H	1
SBR	Rd, K	Set Bit(s) in Register	$Rd \leftarrow Rd \vee K$	Z,N,V	1
CBR	Rd, K	Clear Bit(s) in Register	$Rd \leftarrow Rd \cdot (0xFF - K)$	Z,N,V	1
INC	Rd	Increment	$Rd \leftarrow Rd + 1$	Z,N,V	1
DEC	Rd	Decrement	$Rd \leftarrow Rd - 1$	Z,N,V	1
TST	Rd	Test for Zero or Minus	$Rd \leftarrow Rd \cdot Rd$	Z,N,V	1
CLR	Rd	Clear Register	$Rd \leftarrow Rd \oplus Rd$	Z,N,V	1
SER	Rd	Set Register	$Rd \leftarrow 0xFF$	None	1
MUL	Rd, Rr	Multiply Unsigned	$R1:R0 \leftarrow Rd \times Rr$	Z,C	2
MULS	Rd, Rr	Multiply Signed	$R1:R0 \leftarrow Rd \times Rr$	Z,C	2
MULSU	Rd, Rr	Multiply Signed with Unsigned	$R1:R0 \leftarrow Rd \times Rr$	Z,C	2
FMUL	Rd, Rr	Fractional Multiply Unsigned	$R1:R0 \leftarrow (Rd \times Rr) \ll 1$	Z,C	2
FMULS	Rd, Rr	Fractional Multiply Signed	$R1:R0 \leftarrow (Rd \times Rr) \ll 1$	Z,C	2
FMULSU	Rd, Rr	Fractional Multiply Signed with Unsigned	$R1:R0 \leftarrow (Rd \times Rr) \ll 1$	Z,C	2
BRANCH INSTRUCTIONS					
RJMP	k	Relative Jump	$PC \leftarrow PC + k + 1$	None	2
IJMP		Indirect Jump to (Z)	$PC \leftarrow Z$	None	2
EIJMP		Extended Indirect Jump to (Z)	$PC \leftarrow (EIND:Z)$	None	2
JMP	k	Direct Jump	$PC \leftarrow k$	None	3
RCALL	k	Relative Subroutine Call	$PC \leftarrow PC + k + 1$	None	4
ICALL		Indirect Call to (Z)	$PC \leftarrow Z$	None	4
EICALL		Extended Indirect Call to (Z)	$PC \leftarrow (EIND:Z)$	None	4
CALL	k	Direct Subroutine Call	$PC \leftarrow k$	None	5
RET		Subroutine Return	$PC \leftarrow STACK$	None	5
RETI		Interrupt Return	$PC \leftarrow STACK$	I	5
CPSE	Rd, Rr	Compare, Skip if Equal	if (Rd = Rr) $PC \leftarrow PC + 2$ or 3	None	1/2/3
CP	Rd, Rr	Compare	$Rd - Rr$	Z, N, V, C, H	1
CPC	Rd, Rr	Compare with Carry	$Rd - Rr - C$	Z, N, V, C, H	1
CPI	Rd, K	Compare Register with Immediate	$Rd - K$	Z, N, V, C, H	1
SBRC	Rr, b	Skip if Bit in Register Cleared	if (Rr(b)=0) $PC \leftarrow PC + 2$ or 3	None	1/2/3
SBRS	Rr, b	Skip if Bit in Register is Set	if (Rr(b)=1) $PC \leftarrow PC + 2$ or 3	None	1/2/3
SBIC	P, b	Skip if Bit in I/O Register Cleared	if (P(b)=0) $PC \leftarrow PC + 2$ or 3	None	1/2/3
SBIS	P, b	Skip if Bit in I/O Register is Set	if (P(b)=1) $PC \leftarrow PC + 2$ or 3	None	1/2/3
BRBS	s, k	Branch if Status Flag Set	if (SREG(s) = 1) then $PC \leftarrow PC + k + 1$	None	1/2
BRBC	s, k	Branch if Status Flag Cleared	if (SREG(s) = 0) then $PC \leftarrow PC + k + 1$	None	1/2
BREQ	k	Branch if Equal	if (Z = 1) then $PC \leftarrow PC + k + 1$	None	1/2
BRNE	k	Branch if Not Equal	if (Z = 0) then $PC \leftarrow PC + k + 1$	None	1/2
BRCS	k	Branch if Carry Set	if (C = 1) then $PC \leftarrow PC + k + 1$	None	1/2
BRCC	k	Branch if Carry Cleared	if (C = 0) then $PC \leftarrow PC + k + 1$	None	1/2
BRSH	k	Branch if Same or Higher	if (C = 0) then $PC \leftarrow PC + k + 1$	None	1/2
BRLO	k	Branch if Lower	if (C = 1) then $PC \leftarrow PC + k + 1$	None	1/2
BRMI	k	Branch if Minus	if (N = 1) then $PC \leftarrow PC + k + 1$	None	1/2
BRPL	k	Branch if Plus	if (N = 0) then $PC \leftarrow PC + k + 1$	None	1/2
BRGE	k	Branch if Greater or Equal, Signed	if (N ⊕ V = 0) then $PC \leftarrow PC + k + 1$	None	1/2
BRLT	k	Branch if Less Than Zero, Signed	if (N ⊕ V = 1) then $PC \leftarrow PC + k + 1$	None	1/2
BRHS	k	Branch if Half Carry Flag Set	if (H = 1) then $PC \leftarrow PC + k + 1$	None	1/2
BRHC	k	Branch if Half Carry Flag Cleared	if (H = 0) then $PC \leftarrow PC + k + 1$	None	1/2
BRTS	k	Branch if T Flag Set	if (T = 1) then $PC \leftarrow PC + k + 1$	None	1/2
BRTC	k	Branch if T Flag Cleared	if (T = 0) then $PC \leftarrow PC + k + 1$	None	1/2
BRVS	k	Branch if Overflow Flag is Set	if (V = 1) then $PC \leftarrow PC + k + 1$	None	1/2



Mnemonics	Operands	Description	Operation	Flags	#Clocks
BRVC	k	Branch if Overflow Flag is Cleared	if (V = 0) then PC ← PC + k + 1	None	1/2
BRIE	k	Branch if Interrupt Enabled	if (I = 1) then PC ← PC + k + 1	None	1/2
BRID	k	Branch if Interrupt Disabled	if (I = 0) then PC ← PC + k + 1	None	1/2
BIT AND BIT-TEST INSTRUCTIONS					
SBI	P,b	Set Bit in I/O Register	I/O(P,b) ← 1	None	2
CBI	P,b	Clear Bit in I/O Register	I/O(P,b) ← 0	None	2
LSL	Rd	Logical Shift Left	Rd(n+1) ← Rd(n), Rd(0) ← 0	Z,C,N,V	1
LSR	Rd	Logical Shift Right	Rd(n) ← Rd(n+1), Rd(7) ← 0	Z,C,N,V	1
ROL	Rd	Rotate Left Through Carry	Rd(0) ← C, Rd(n+1) ← Rd(n), C ← Rd(7)	Z,C,N,V	1
ROR	Rd	Rotate Right Through Carry	Rd(7) ← C, Rd(n) ← Rd(n+1), C ← Rd(0)	Z,C,N,V	1
ASR	Rd	Arithmetic Shift Right	Rd(n) ← Rd(n+1), n=0..6	Z,C,N,V	1
SWAP	Rd	Swap Nibbles	Rd(3..0) ← Rd(7..4), Rd(7..4) ← Rd(3..0)	None	1
BSET	s	Flag Set	SREG(s) ← 1	SREG(s)	1
BCLR	s	Flag Clear	SREG(s) ← 0	SREG(s)	1
BST	Rr, b	Bit Store from Register to T	T ← Rr(b)	T	1
BLD	Rd, b	Bit load from T to Register	Rd(b) ← T	None	1
SEC		Set Carry	C ← 1	C	1
CLC		Clear Carry	C ← 0	C	1
SEN		Set Negative Flag	N ← 1	N	1
CLN		Clear Negative Flag	N ← 0	N	1
SEZ		Set Zero Flag	Z ← 1	Z	1
CLZ		Clear Zero Flag	Z ← 0	Z	1
SEI		Global Interrupt Enable	I ← 1	I	1
CLI		Global Interrupt Disable	I ← 0	I	1
SES		Set Signed Test Flag	S ← 1	S	1
CLS		Clear Signed Test Flag	S ← 0	S	1
SEV		Set Twos Complement Overflow.	V ← 1	V	1
CLV		Clear Twos Complement Overflow	V ← 0	V	1
SET		Set T in SREG	T ← 1	T	1
CLT		Clear T in SREG	T ← 0	T	1
SEH		Set Half Carry Flag in SREG	H ← 1	H	1
CLH		Clear Half Carry Flag in SREG	H ← 0	H	1
DATA TRANSFER INSTRUCTIONS					
MOV	Rd, Rr	Move Between Registers	Rd ← Rr	None	1
MOVW	Rd, Rr	Copy Register Word	Rd+1:Rd ← Rr+1:Rr	None	1
LDI	Rd, K	Load Immediate	Rd ← K	None	1
LD	Rd, X	Load Indirect	Rd ← (X)	None	2
LD	Rd, X+	Load Indirect and Post-Inc.	Rd ← (X), X ← X + 1	None	2
LD	Rd, -X	Load Indirect and Pre-Dec.	X ← X - 1, Rd ← (X)	None	2
LD	Rd, Y	Load Indirect	Rd ← (Y)	None	2
LD	Rd, Y+	Load Indirect and Post-Inc.	Rd ← (Y), Y ← Y + 1	None	2
LD	Rd, -Y	Load Indirect and Pre-Dec.	Y ← Y - 1, Rd ← (Y)	None	2
LDD	Rd, Y+q	Load Indirect with Displacement	Rd ← (Y + q)	None	2
LD	Rd, Z	Load Indirect	Rd ← (Z)	None	2
LD	Rd, Z+	Load Indirect and Post-Inc.	Rd ← (Z), Z ← Z+1	None	2
LD	Rd, -Z	Load Indirect and Pre-Dec.	Z ← Z - 1, Rd ← (Z)	None	2
LDD	Rd, Z+q	Load Indirect with Displacement	Rd ← (Z + q)	None	2
LDS	Rd, k	Load Direct from SRAM	Rd ← (k)	None	2
ST	X, Rr	Store Indirect	(X) ← Rr	None	2
ST	X+, Rr	Store Indirect and Post-Inc.	(X) ← Rr, X ← X + 1	None	2
ST	-X, Rr	Store Indirect and Pre-Dec.	X ← X - 1, (X) ← Rr	None	2
ST	Y, Rr	Store Indirect	(Y) ← Rr	None	2
ST	Y+, Rr	Store Indirect and Post-Inc.	(Y) ← Rr, Y ← Y + 1	None	2
ST	-Y, Rr	Store Indirect and Pre-Dec.	Y ← Y - 1, (Y) ← Rr	None	2
STD	Y+q, Rr	Store Indirect with Displacement	(Y + q) ← Rr	None	2
ST	Z, Rr	Store Indirect	(Z) ← Rr	None	2
ST	Z+, Rr	Store Indirect and Post-Inc.	(Z) ← Rr, Z ← Z + 1	None	2
ST	-Z, Rr	Store Indirect and Pre-Dec.	Z ← Z - 1, (Z) ← Rr	None	2
STD	Z+q, Rr	Store Indirect with Displacement	(Z + q) ← Rr	None	2
STS	k, Rr	Store Direct to SRAM	(k) ← Rr	None	2
LPM		Load Program Memory	R0 ← (Z)	None	3
LPM	Rd, Z	Load Program Memory	Rd ← (Z)	None	3
LPM	Rd, Z+	Load Program Memory and Post-Inc	Rd ← (Z), Z ← Z+1	None	3
ELPM		Extended Load Program Memory	R0 ← (RAMPZ:Z)	None	3
ELPM	Rd, Z	Extended Load Program Memory	Rd ← (Z)	None	3
ELPM	Rd, Z+	Extended Load Program Memory	Rd ← (RAMPZ:Z), RAMPZ:Z ← RAMPZ:Z+1	None	3

Mnemonics	Operands	Description	Operation	Flags	#Clocks
SPM		Store Program Memory	(Z) ← R1:R0	None	-
IN	Rd, P	In Port	Rd ← P	None	1
OUT	P, Rr	Out Port	P ← Rr	None	1
PUSH	Rr	Push Register on Stack	STACK ← Rr	None	2
POP	Rd	Pop Register from Stack	Rd ← STACK	None	2
MCU CONTROL INSTRUCTIONS					
NOP		No Operation		None	1
SLEEP		Sleep	(see specific description for Sleep function)	None	1
WDR		Watchdog Reset	(see specific description for WDR/timer)	None	1
BREAK		Break	For On-chip Debug Only	None	N/A

6. Ordering Information

6.1 ATmega16U4

Speed (MHz)	Power Supply	Ordering Code	Package	Operation Range
16	2.7 - 5.5	ATmega16U4-AU	44ML	Industrial (-40° to +85°C)
		ATmega16U4-MU	44PW	

Package Type	
44ML	ML, 44 - Lead, 10 x 10 mm Body Size, 1.0 mm Body Thickness 0.8 mm Lead Pitch, Thin Profile Plastic Quad Flat Package (TQFP)
44PW	PW, 44 - Lead 7.0 x 7.0 mm Body, 0.50 mm Pitch Quad Flat No Lead Package (QFN)

6.2 ATmega32U4

Speed (MHz)	Power Supply	Ordering Code	Package	Operation Range
16	2.7 - 5.5	ATmega32U4-AU	44ML	Industrial (-40° to +85°C)
		ATmega32U4-MU	44PW	

Package Type	
44ML	ML, 44 - Lead, 10 x 10 mm Body Size, 1.0 mm Body Thickness 0.8 mm Lead Pitch, Thin Profile Plastic Quad Flat Package (TQFP)
44PW	PW, 44 - Lead 7.0 x 7.0 mm Body, 0.50 mm Pitch Quad Flat No Lead Package (QFN)

7. Packaging Information

7.1 TQFP44

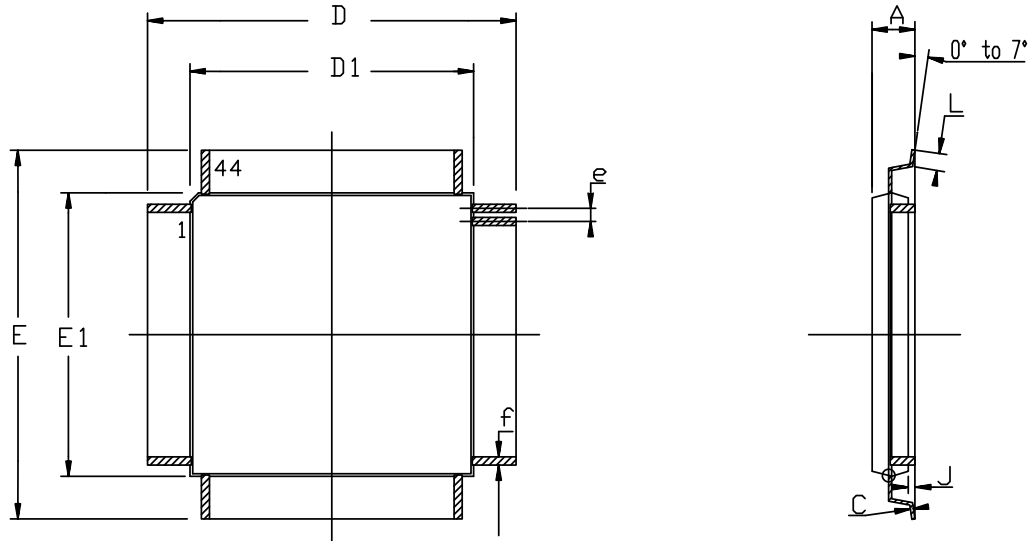

COMMON DIMENSIONS IN MM

SYMBOL	Min	Max	NOTES
A	----	1.20	
A1	0.95	1.05	
C	0.09	0.20	
D	12.00 BSC		
D1	10.00 BSC		
E	12.00 BSC		
E1	10.00 BSC		
J	0.05	0.15	
L	0.45	0.75	
e	0.80 BSC		
f	0.30	0.45	

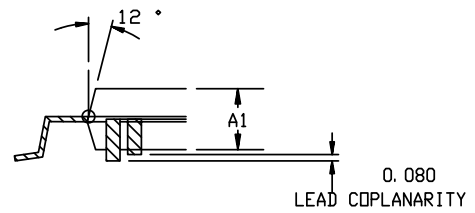

07/27/07

ATMEL Atmel Nantes S.A.
La Chantrerie - BP 70602
44306 Nantes Cedex 3 - France

TITLE
ML, 44 - Lead, 10x10 mm Body Size, 1.0 mm Body Thickness
0.8 mm Lead Pitch, Thin Profile Plastic Quad Flat Package (TQFP)

DRAWING No.
ML

REV.
G

7.2 QFN44

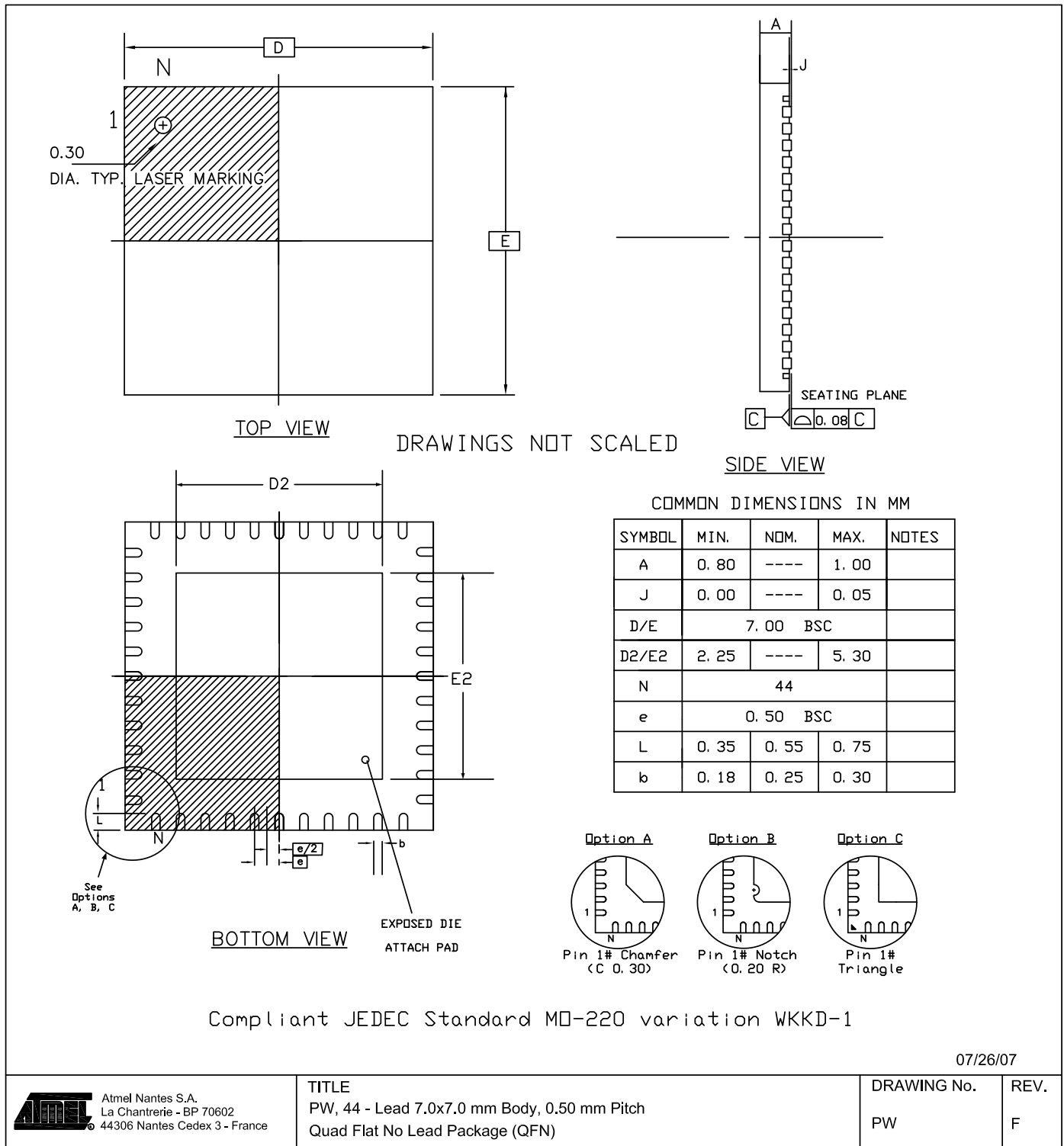

8. Errata

The revision letter in this section refers to the revision of the ATmega16U4/ATmega32U4 device.

8.1 ATmega16U4/ATmega32U4 Rev A

1. Spike on TWI pins when TWI is enabled

100 ns negative spike occurs on SDA and SCL pins when TWI is enabled.

Problem Fix/work around

No known work around, enable ATmega16U4/ATmega32U4 TWI first versus the others nodes of the TWI network.

2. High current consumption in sleep mode

If a pending interrupt cannot wake the part up from the selected mode, the current consumption will increase during sleep when executing the SLEEP instruction directly after a SEI instruction.

Problem Fix/work around

Before entering sleep, interrupts not used to wake up the part from the sleep mode should be disabled.

3. Extra power consumption

The typical power consumption is increased by about 30 μ A in power-down mode.

Problem Fix/work around

None.

4. Internal RC oscillator start up issue.

When the part is configured to start on internal RC, the oscillator may not start properly after power-on.

Problem Fix/work around

Do not configure the part to start with the internal oscillator (default part configuration is to start with the external crystal oscillator).

5. Internal RC oscillator calibration issue.

The default internal RC oscillator frequency may be lower than 8MHz.

Problem Fix/work around

Parts are configured so that the internal RC oscillator frequency is as close as possible to the 8MHz default target frequency.

9. Incorrect CPU behavior for VBUSTI interrupt routine

The CPU core may incorrectly execute the interrupt vector related to the VBUSTI interrupt flag.

Problem fix/workaround

Do not enable this interrupt, firmware must process this USB event by polling VBUSTI.

9. Datasheet Revision History for ATmega16U4/ATmega32U4

Please note that the referring page numbers in this section are referred to this document. The referring revision in this section are referring to the document revision.

9.1 Rev. 7766D – 01/09

1. Updated Memory section in [“Features” on page 1](#).
2. Added section [“Resources” on page 8](#).
3. Added section [“Data Retention” on page 8](#).
4. Updated [“Ordering Information” on page 16](#).

9.2 Rev. 7766C – 11/08

1. Updated Memory section in [“Features” on page 1](#).

9.3 Rev. 7766B – 11/08

1. Added ATmega16U4 device.
2. Created errata section and added ATmega16U4.
3. Updated High Speed Timer, asynchronous description [Section 15. on page 139](#)

9.4 Rev. 7766A – 07/08

1. Initial revision