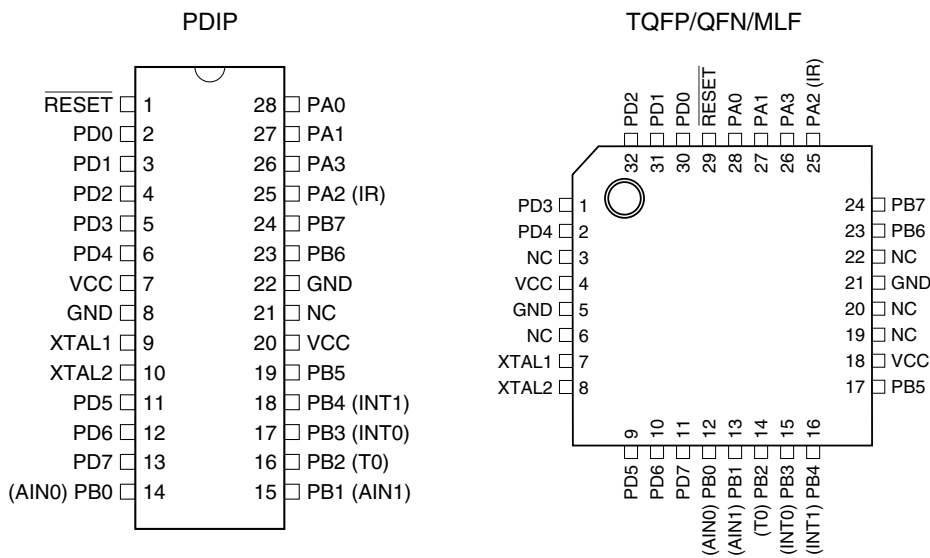


## Features

- Utilizes the AVR<sup>®</sup> RISC Architecture
- AVR – High-performance and Low-power RISC Architecture
  - 90 Powerful Instructions – Most Single Clock Cycle Execution
  - 32 x 8 General-purpose Working Registers
  - Up to 4 MIPS Throughput at 4 MHz
- Nonvolatile Program Memory
  - 2K Bytes of Flash Program Memory
  - Endurance: 1,000 Write/Erase Cycles
  - Programming Lock for Flash Program Data Security
- Peripheral Features
  - Interrupt and Wake-up on Low-level Input
  - One 8-bit Timer/Counter with Separate Prescaler
  - On-chip Analog Comparator
  - Programmable Watchdog Timer with On-chip Oscillator
  - Built-in High-current LED Driver with Programmable Modulation
- Special Microcontroller Features
  - Low-power Idle and Power-down Modes
  - External and Internal Interrupt Sources
  - Power-on Reset Circuit with Programmable Start-up Time
  - Internal Calibrated RC Oscillator
- Power Consumption at 1 MHz, 2V, 25°C
  - Active: 3.0 mA
  - Idle Mode: 1.2 mA
  - Power-down Mode: <1 μA
- I/O and Packages
  - 11 Programmable I/O Lines, 8 Input Lines and a High-current LED Driver
  - 28-lead PDIP, 32-lead TQFP, and 32-pad MLF
- Operating Voltages
  - V<sub>CC</sub>: 1.8V - 5.5V for the ATtiny28V
  - V<sub>CC</sub>: 2.7V - 5.5V for the ATtiny28L
- Speed Grades
  - 0 - 1.2 MHz for the ATtiny28V
  - 0 - 4 MHz For the ATtiny28L

## Pin Configurations



8-bit AVR<sup>®</sup>  
Microcontroller  
with 2K Bytes of  
Flash

ATtiny28L  
ATtiny28V

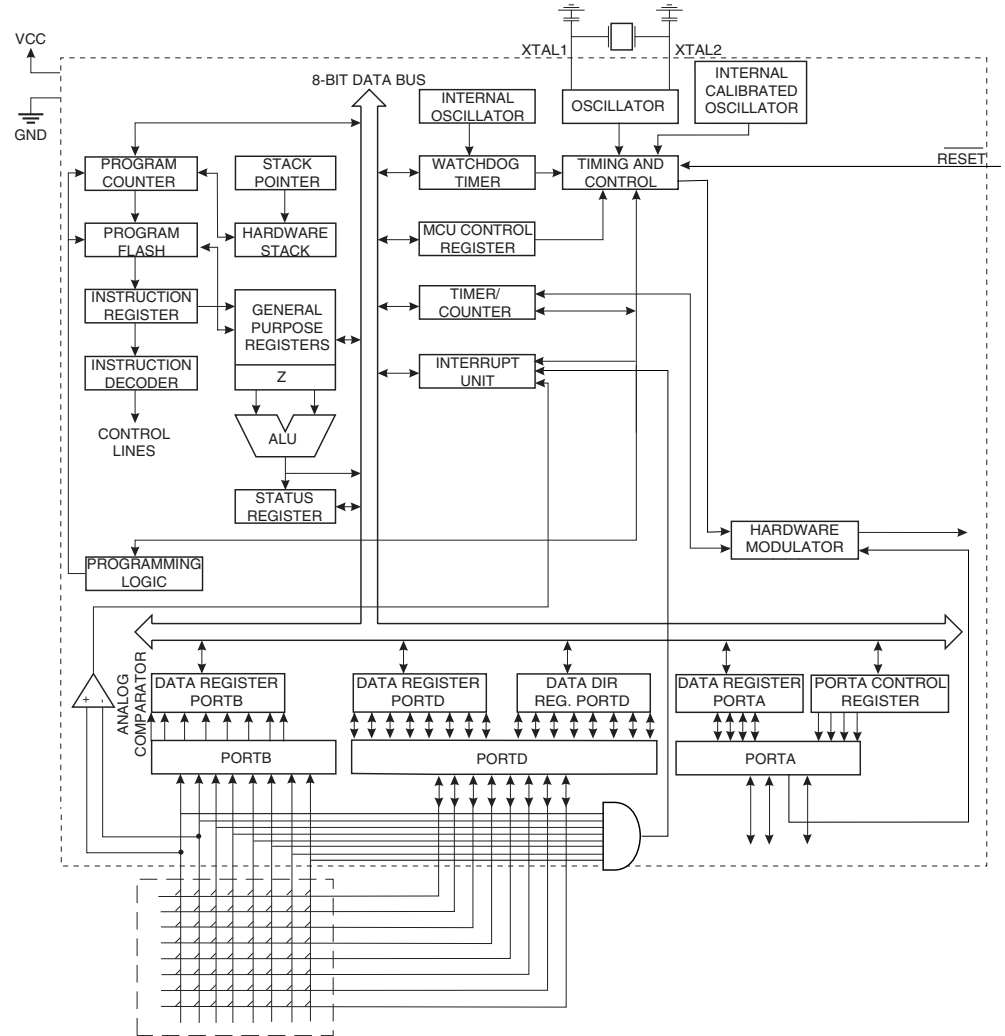


## Description

The ATtiny28 is a low-power CMOS 8-bit microcontroller based on the AVR RISC architecture. By executing powerful instructions in a single clock cycle, the ATtiny28 achieves throughputs approaching 1 MIPS per MHz, allowing the system designer to optimize power consumption versus processing speed. The AVR core combines a rich instruction set with 32 general-purpose working registers. All the 32 registers are directly connected to the Arithmetic Logic Unit (ALU), allowing two independent registers to be accessed in one single instruction executed in one clock cycle. The resulting architecture is more code efficient while achieving throughputs up to ten times faster than conventional CISC microcontrollers.

## Block Diagram

Figure 1. The ATtiny28 Block Diagram



The ATtiny28 provides the following features: 2K bytes of Flash, 11 general-purpose I/O lines, 8 input lines, a high-current LED driver, 32 general-purpose working registers, an 8-bit timer/counter, internal and external interrupts, programmable Watchdog Timer with internal oscillator and 2 software-selectable power-saving modes. The Idle Mode stops the CPU while allowing the timer/counter and interrupt system to continue functioning. The Power-down mode saves the register contents but freezes the oscillator, disabling all other chip functions until the next interrupt or hardware reset. The wake-up or inter-

rupt on low-level input feature enables the ATtiny28 to be highly responsive to external events, still featuring the lowest power consumption while in the power-down modes.

The device is manufactured using Atmel's high-density, nonvolatile memory technology. By combining an enhanced RISC 8-bit CPU with Flash on a monolithic chip, the Atmel ATtiny28 is a powerful microcontroller that provides a highly flexible and cost-effective solution to many embedded control applications. The ATtiny28 AVR is supported with a full suite of program and system development tools including: macro assemblers, program debugger/simulators, in-circuit emulators and evaluation kits.

## Pin Descriptions

<b>VCC</b>	Supply voltage pin.
<b>GND</b>	Ground pin.
<b>Port A (PA3..PA0)</b>	Port A is a 4-bit I/O port. PA2 is output-only and can be used as a high-current LED driver. At $V_{CC} = 2.0V$ , the PA2 output buffer can sink 25 mA. PA3, PA1 and PA0 are bi-directional I/O pins with internal pull-ups (selected for each bit). The port pins are tri-stated when a reset condition becomes active, even if the clock is not running.
<b>Port B (PB7..PB0)</b>	Port B is an 8-bit input port with internal pull-ups (selected for all Port B pins). Port B pins that are externally pulled low will source current if the pull-ups are activated.  Port B also serves the functions of various special features of the ATtiny28 as listed on page 27. If any of the special features are enabled, the pull-up(s) on the corresponding pin(s) is automatically disabled. The port pins are tri-stated when a reset condition becomes active, even if the clock is not running.
<b>Port D (PD7..PD0)</b>	Port D is an 8-bit I/O port. Port pins can provide internal pull-up resistors (selected for each bit). The port pins are tri-stated when a reset condition becomes active, even if the clock is not running.
<b>XTAL1</b>	Input to the inverting oscillator amplifier and input to the internal clock operating circuit.
<b>XTAL2</b>	Output from the inverting oscillator amplifier.
<b><math>\overline{\text{RESET}}</math></b>	Reset input. An external reset is generated by a low level on the $\overline{\text{RESET}}$ pin. Reset pulses longer than 50 ns will generate a reset, even if the clock is not running. Shorter pulses are not guaranteed to generate a reset.

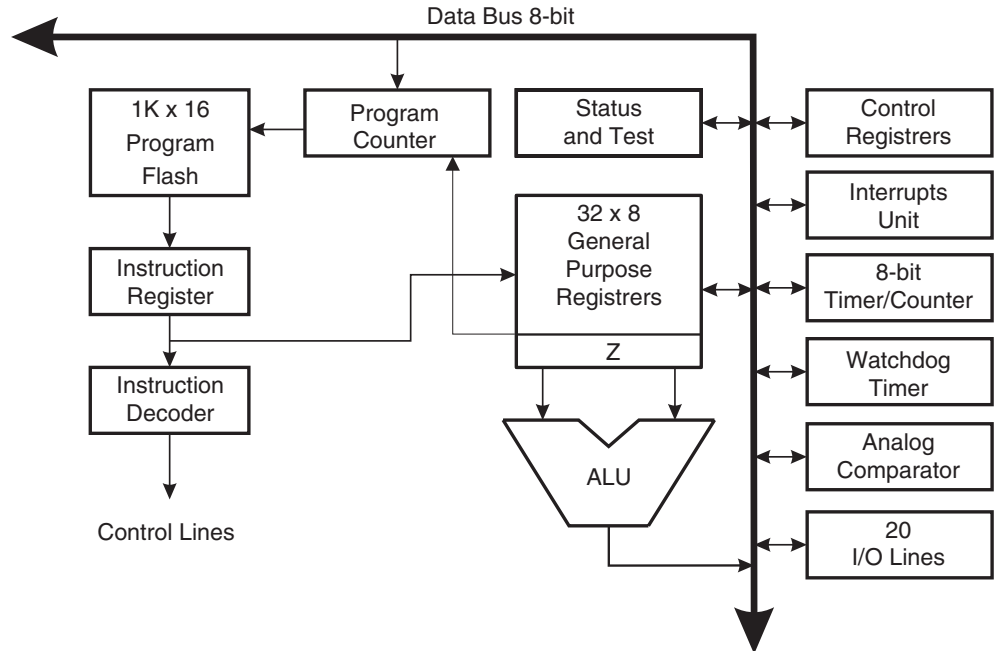
**Figure 2.**

## Architectural Overview

The fast-access register file concept contains 32 x 8-bit general-purpose working registers with a single clock cycle access time. This means that during one single clock cycle, one ALU (Arithmetic Logic Unit) operation is executed. Two operands are output from the register file, the operation is executed, and the result is stored back in the register file – in one clock cycle.

Two of the 32 registers can be used as a 16-bit pointer for indirect memory access. This pointer is called the Z-pointer and can address the register file and the Flash program memory.

**Figure 3.** The ATtiny28 AVR RISC Architecture



The ALU supports arithmetic and logic functions between registers or between a constant and a register. Single register operations are also executed in the ALU. Figure 3 shows the ATtiny28 AVR RISC microcontroller architecture. The AVR uses a Harvard architecture concept – with separate memories and buses for program and data memories. The program memory is accessed with a two-stage pipeline. While one instruction is being executed, the next instruction is pre-fetched from the program memory. This concept enables instructions to be executed every clock cycle. The program memory is reprogrammable Flash memory.

With the relative jump and relative call instructions, the whole 1K address space is directly accessed. All AVR instructions have a single 16-bit word format, meaning that every program memory address contains a single 16-bit instruction.

During interrupts and subroutine calls, the return address program counter (PC) is stored on the stack. The stack is a 3-level-deep hardware stack dedicated for subroutines and interrupts.

The I/O memory space contains 64 addresses for CPU peripheral functions such as Control Registers, Timer/Counters and other I/O functions. The memory spaces in the AVR architecture are all linear and regular memory maps.

A flexible interrupt module has its control registers in the I/O space with an additional global interrupt enable bit in the status register. All the different interrupts have a sepa-

rate interrupt vector in the interrupt vector table at the beginning of the program memory. The different interrupts have priority in accordance with their interrupt vector position. The lower the interrupt vector address, the higher the priority.

## ALU – Arithmetic Logic Unit

The high-performance AVR ALU operates in direct connection with all the 32 general-purpose working registers. Within a single clock cycle, ALU operations between registers in the register file are executed. The ALU operations are divided into three main categories – arithmetic, logic and bit functions. Some microcontrollers in the AVR product family feature a hardware multiplier in the arithmetic part of the ALU.

## Subroutine and Interrupt Hardware Stack

The ATtiny28 uses a 3-level-deep hardware stack for subroutines and interrupts. The hardware stack is 10 bits wide and stores the program counter (PC) return address while subroutines and interrupts are executed.

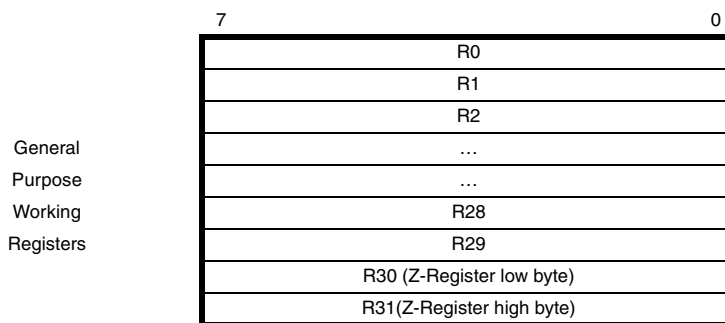
RCALL instructions and interrupts push the PC return address onto stack level 0, and the data in the other stack levels 1 - 2 are pushed one level deeper in the stack. When a RET or RETI instruction is executed the returning PC is fetched from stack level 0, and the data in the other stack levels 1 - 2 are popped one level in the stack.

If more than three subsequent subroutine calls or interrupts are executed, the first values written to the stack are overwritten.

## General-purpose Register File

Figure 4 shows the structure of the 32 general-purpose registers in the CPU.

**Figure 4.** AVR CPU General-purpose Working Registers



All the register operating instructions in the instruction set have direct and single cycle access to all registers. The only exception are the five constant arithmetic and logic instructions SBCI, SUBI, CPI, ANDI and ORI between a constant and a register and the LDI instruction for load immediate constant data. These instructions apply to the second half of the registers in the register file – R16..R31. The general SBC, SUB, CP, AND, OR and all other operations between two registers or on a single register apply to the entire register file.

Registers 30 and 31 form a 16-bit pointer (the Z-pointer), which is used for indirect Flash memory and register file access. When the register file is accessed, the contents of R31 are discarded by the CPU.

## Status Register

### Status Register – SREG

The AVR status register (SREG) at I/O space location \$3F is defined as:

Bit	7	6	5	4	3	2	1	0	
\$3F	I	T	H	S	V	N	Z	C	SREG
Read/Write	R/W	R/W	R/W	R/W	R/W	R/W	R/W	R/W	
Initial Value	0	0	0	0	0	0	0	0	

- **Bit 7 – I: Global Interrupt Enable**

The global interrupt enable bit must be set (one) for the interrupts to be enabled. The individual interrupt enable control is then performed in separate control registers. If the global interrupt enable register is cleared (zero), none of the interrupts are enabled independent of the individual interrupt enable settings. The I-bit is cleared by hardware after an interrupt has occurred, and is set by the RETI instruction to enable subsequent interrupts.

- **Bit 6 – T: Bit Copy Storage**

The bit copy instructions BLD (Bit Load) and BST (Bit Store) use the T-bit as source and destination for the operated bit. A bit from a register in the register file can be copied into T by the BST instruction, and a bit in T can be copied into a bit in a register in the register file by the BLD instruction.

- **Bit 5 – H: Half-carry Flag**

The half-carry flag H indicates a half-carry in some arithmetic operations. See the Instruction Set description for detailed information.

- **Bit 4 – S: Sign Bit,  $S = N \oplus V$**

The S-bit is always an exclusive or between the negative flag N and the two's complement overflow flag V. See the Instruction Set description for detailed information.

- **Bit 3 – V: Two's Complement Overflow Flag**

The two's complement overflow flag V supports two's complement arithmetic. See the Instruction Set description for detailed information.

- **Bit 2 – N: Negative Flag**

The negative flag N indicates a negative result from an arithmetical or logical operation. See the Instruction Set description for detailed information.

- **Bit 1 – Z: Zero Flag**

The zero flag Z indicates a zero result from an arithmetical or logical operation. See the Instruction Set description for detailed information.

- **Bit 0 – C: Carry Flag**

The carry flag C indicates a carry in an arithmetical or logical operation. See the Instruction Set description for detailed information.

Note that the status register is not automatically stored when entering an interrupt routine and restored when returning from an interrupt routine. This must be handled by software.

## System Clock and Clock Options

The device has the following clock source options, selectable by Flash Fuse bits as shown in Table 1.

**Table 1.** Device Clocking Option Select

Clock Option	CKSEL3..0
External Crystal/Ceramic Resonator	1111 - 1010
External Low-frequency Crystal	1001 - 1000
External RC Oscillator	0111 - 0101
Internal RC Oscillator	0100 - 0010
External Clock	0001 - 0000

Note: “1” means unprogrammed, “0” means programmed.

The various choices for each clocking option give different start-up times as shown in Table 5 on page 16.

## Internal RC Oscillator

The internal RC oscillator option is an on-chip calibrated oscillator running at a nominal frequency of 1.2 MHz. If selected, the device can operate with no external components. The device is shipped with this option selected.

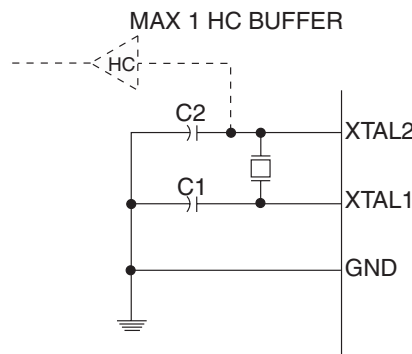
## Calibrated Internal RC Oscillator

The calibrated internal oscillator provides a fixed 1.2 MHz (nominal) clock at 3V and 25°C. This clock may be used as the system clock. This oscillator can be calibrated by writing the calibration byte to the OSCCAL register. When this oscillator is used as the chip clock, the Watchdog oscillator will still be used for the Watchdog Timer and for the reset time-out. For details on how to use the pre-programmed calibration value, see the section “Calibration Byte” on page 46.

## Crystal Oscillator

XTAL1 and XTAL2 are input and output, respectively, of an inverting amplifier, which can be configured for use as an on-chip oscillator, as shown in Figure 5. Either a quartz crystal or a ceramic resonator may be used. When the INTCAP fuse is programmed, internal load capacitors with typical values 50 pF are connected between XTAL1/XTAL2 and ground.

**Figure 5.** Oscillator Connections

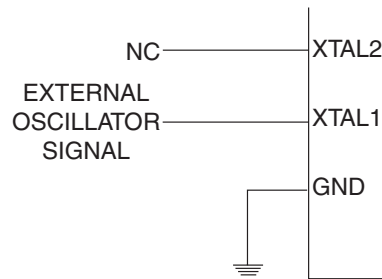


Note: 1. When using the MCU oscillator as a clock for an external device, an HC buffer should be connected as indicated in the figure.

## External Clock

To drive the device from an external clock source, XTAL2 should be left unconnected while XTAL1 is driven as shown in Figure 6.

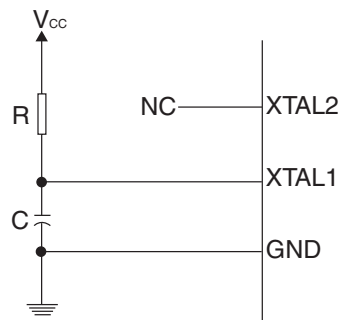
**Figure 6.** External Clock Drive Configuration



### External RC Oscillator

For timing insensitive applications, the external RC configuration shown in Figure 7 can be used. For details on how to choose R and C, see Table 25 on page 56.

**Figure 7.** External RC Configuration





## Register Description

### Oscillator Calibration Register – OSCCAL

Bit	7	6	5	4	3	2	1	0	
\$00	<b>CAL7</b>	<b>CAL6</b>	<b>CAL5</b>	<b>CAL4</b>	<b>CAL3</b>	<b>CAL2</b>	<b>CAL1</b>	<b>CAL0</b>	OSCCAL
Read/Write	R/W	R/W	R/W	R/W	R/W	R/W	R/W	R/W	
Initial Value	0	0	0	0	0	0	0	0	

- **Bits 7..0 – CAL7..CAL0: Oscillator Calibration Value**

Writing the calibration byte to this address will trim the internal oscillator to remove process variation from the oscillator frequency. When OSCCAL is zero, the lowest available frequency is chosen. Writing non-zero values to the register will increase the frequency to the internal oscillator. Writing \$FF to the register gives the highest available frequency. Table 2 shows the range for OSCCAL. Note that the oscillator is intended for calibration to 1.2 MHz, thus tuning to other values is not guaranteed. At 3V and 25°C, the pre-programmed calibration byte gives a frequency within  $\pm 1\%$  of the nominal frequency.

**Table 2.** Internal RC Oscillator Range

OSCCAL Value	Min Frequency	Max Frequency
0x00	0.6 MHz	1.2 MHz
0x7F	0.8 MHz	1.7 MHz
0xFF	1.2 MHz	2.5 MHz

## Memories

### I/O Memory

The I/O space definition of the ATtiny28 is shown in Table 3.

**Table 3.** ATtiny28 I/O Space

Address Hex	Name	Function
\$3F	SREG	Status Register
\$1B	PORTA	Data Register, Port A
\$1A	PACR	Port A Control Register
\$19	PINA	Input Pins, Port A
\$16	PINB	Input Pins, Port B
\$12	PORTD	Data Register, Port D
\$11	DDRD	Data Direction Register, Port D
\$10	PIND	Input Pins, Port D
\$08	ACSR	Analog Comparator Control and Status Register
\$07	MCUCS	MCU Control and Status Register
\$06	ICR	Interrupt Control Register
\$05	IFR	Interrupt Flag Register
\$04	TCCR0	Timer/Counter0 Control Register
\$03	TCNT0	Timer/Counter0 (8-bit)
\$02	MODCR	Modulation Control Register
\$01	WDTCR	Watchdog Timer Control Register
\$00	OSCCAL	Oscillator Calibration Register

Note: Reserved and unused locations are not shown in the table.

All ATtiny28 I/O and peripherals are placed in the I/O space. The I/O locations are accessed by the IN and OUT instructions transferring data between the 32 general-purpose working registers and the I/O space. I/O registers within the address range \$00 - \$1F are directly bit-accessible using the SBI and CBI instructions. In these registers, the value of single bits can be checked by using the SBIS and SBIC instructions. Refer to the Instruction Set section for more details.

For compatibility with future devices, reserved bits should be written to zero if accessed. Reserved I/O memory addresses should never be written.

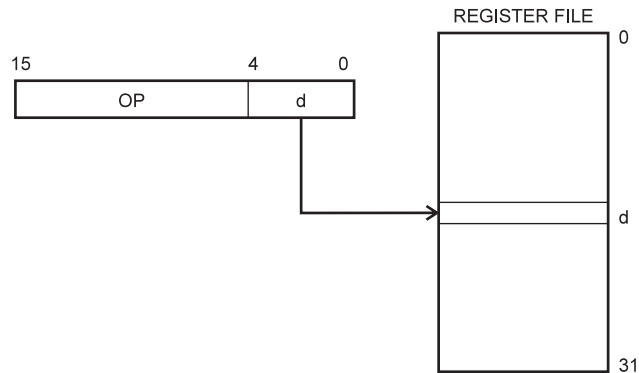
The I/O and peripherals control registers are explained in the following sections.

## Program and Data Addressing Modes

The ATtiny28 AVR RISC microcontroller supports powerful and efficient addressing modes. This section describes the different addressing modes supported in the ATtiny28. In the figures, OP means the operation code part of the instruction word. To simplify, not all figures show the exact location of the addressing bits.

### Register Direct, Single Register Rd

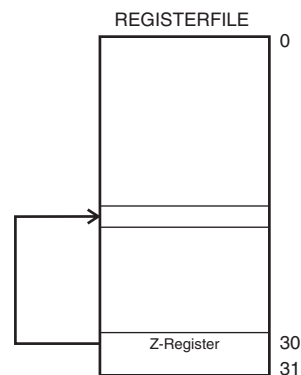
**Figure 8.** Direct Single Register Addressing



The operand is contained in register d (Rd).

### Register Indirect

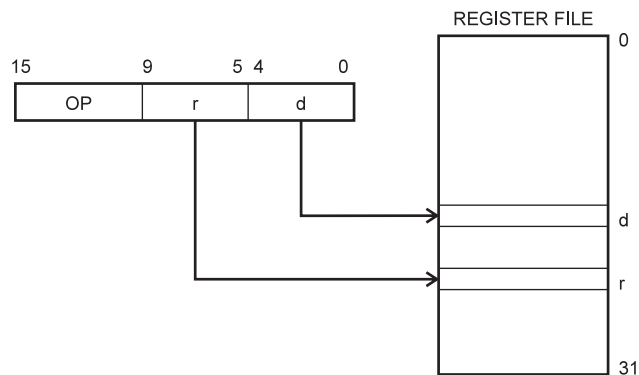
**Figure 9.** Indirect Register Addressing



The register accessed is the one pointed to by the Z-register (R31, R30).

### Register Direct, Two Registers Rd and Rr

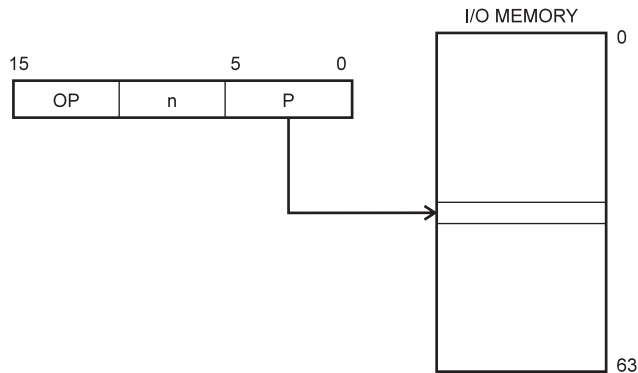
**Figure 10.** Direct Register Addressing, Two Registers



Operands are contained in register r (Rr) and d (Rd). The result is stored in register d (Rd).

**I/O Direct**

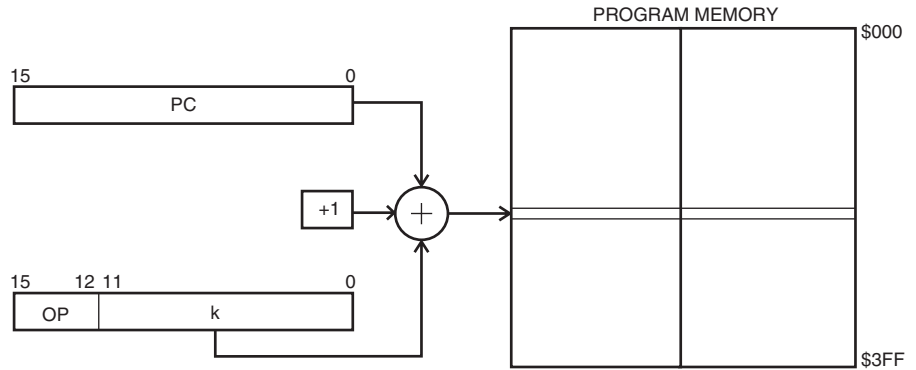
**Figure 11. I/O Direct Addressing**



Operand address is contained in six bits of the instruction word. n is the destination or source register address.

**Relative Program Addressing, RJMP and RCALL**

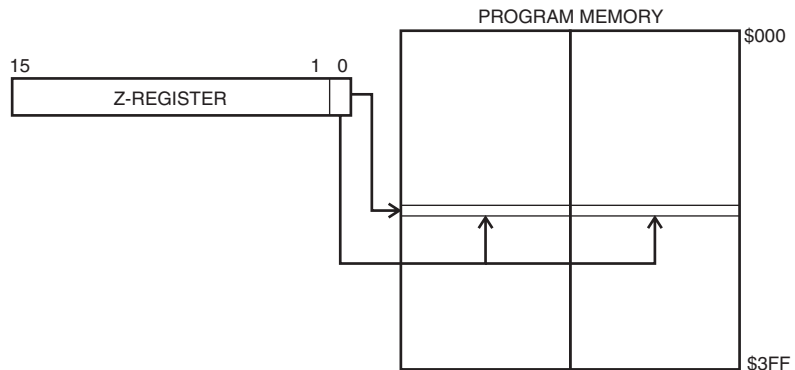
**Figure 12. Relative Program Memory Addressing**



Program execution continues at address  $PC + k + 1$ . The relative address k is -2048 to 2047.

**Constant Addressing Using the LPM Instruction**

**Figure 13. Code Memory Constant Addressing**



Constant byte address is specified by the Z-register contents. The 15 MSBs select word address (0 - 1K), and LSB selects low byte if cleared (LSB = 0) or high byte if set (LSB = 1).

## Memory Access and Instruction Execution Timing

This section describes the general access timing concepts for instruction execution and internal memory access.

The AVR CPU is driven by the System Clock, directly generated from the external clock crystal for the chip. No internal clock division is used.

Figure 14 shows the parallel instruction fetches and instruction executions enabled by the Harvard architecture and the fast-access register file concept. This is the basic pipelining concept to obtain up to 1 MIPS per MHz with the corresponding unique results for functions per cost, functions per clocks and functions per power unit.

**Figure 14.** The Parallel Instruction Fetches and Instruction Executions

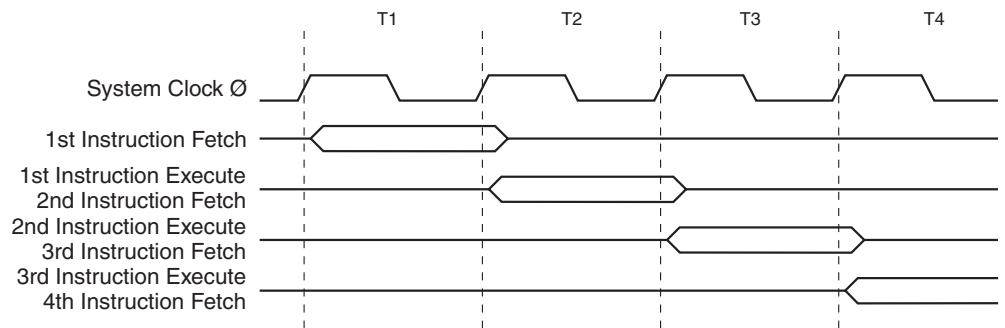
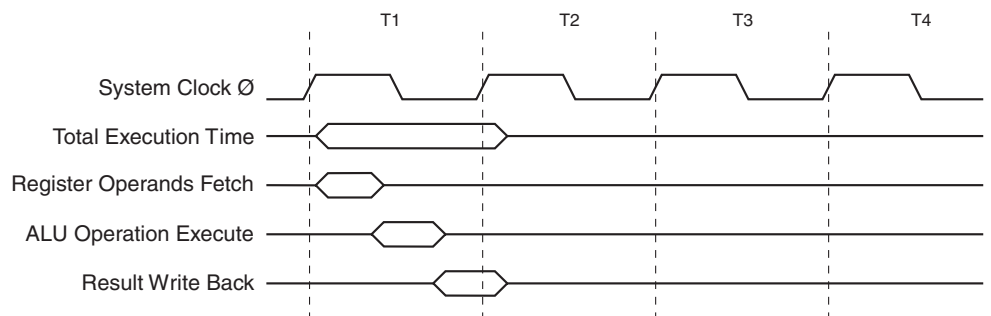


Figure 15 shows the internal timing concept for the register file. In a single clock cycle an ALU operation using two register operands is executed, and the result is stored back to the destination register.

**Figure 15.** Single Cycle ALU Operation



## Flash Program Memory

The ATtiny28 contains 2K bytes of on-chip Flash memory for program storage. Since all instructions are single 16-bit words, the Flash is organized as 1K x 16 words. The Flash memory has an endurance of at least 1,000 write/erase cycles.

The ATtiny28 program counter is 10 bits wide, thus addressing the 1K word Flash program memory. See "Programming the Flash" on page 47 for a detailed description of Flash data downloading.

## Sleep Modes

To enter the sleep modes, the SE bit in MCUCS must be set (one) and a SLEEP instruction must be executed. The SM bit in the MCUCS register selects which sleep mode (Idle or Power-down) will be activated by the SLEEP instruction. If an enabled interrupt occurs while the MCU is in a sleep mode, the MCU awakes. The CPU is then halted for four cycles. It executes the interrupt routine and resumes execution from the instruction following SLEEP. The contents of the register file and I/O memory are unaltered. If a reset occurs during sleep mode, the MCU wakes up and executes from the Reset vector.

### Idle Mode

When the SM bit is cleared (zero), the SLEEP instruction forces the MCU into the Idle Mode, stopping the CPU but allowing Timer/Counters, Watchdog and the interrupt system to continue operating. This enables the MCU to wake up from external triggered interrupts as well as internal ones like Timer Overflow interrupt and Watchdog reset. If wake-up from the Analog Comparator Interrupt is not required, the analog comparator can be powered down by setting the ACD bit in the Analog Comparator Control and Status register (ACSR). This will reduce power consumption in Idle Mode. Note that the ACD bit is set by default.

### Power-down Mode

When the SM bit is set (one), the SLEEP instruction forces the MCU into the Power-down mode. In this mode, the external oscillator is stopped, while the external interrupts and the Watchdog (if enabled) continue operating. Only an external reset, a Watchdog reset (if enabled), or an external level interrupt can wake up the MCU.

Note that if a level-triggered interrupt is used for wake-up from Power-down mode, the changed level must be held for some time to wake up the MCU. This makes the MCU less sensitive to noise. The wake-up period is equal to the clock-counting part of the reset period (see Table 5). The MCU will wake up from power-down if the input has the required level for two Watchdog oscillator cycles. If the wake-up period is shorter than two Watchdog oscillator cycles, the MCU will wake up if the input has the required level for the duration of the wake-up period. If the wake-up condition disappears before the wake-up period has expired, the MCU will wake up from power-down without executing the corresponding interrupt. The period of the Watchdog oscillator is 2.7  $\mu\text{s}$  (nominal) at 3.0V and 25°C. The frequency of the watchdog oscillator is voltage-dependent as shown in the section “Typical Characteristics” on page 57.

When waking up from the Power-down mode, there is a delay from the wake-up condition until the wake-up becomes effective. This allows the clock to restart and become stable after having been stopped.

## System Control and Reset

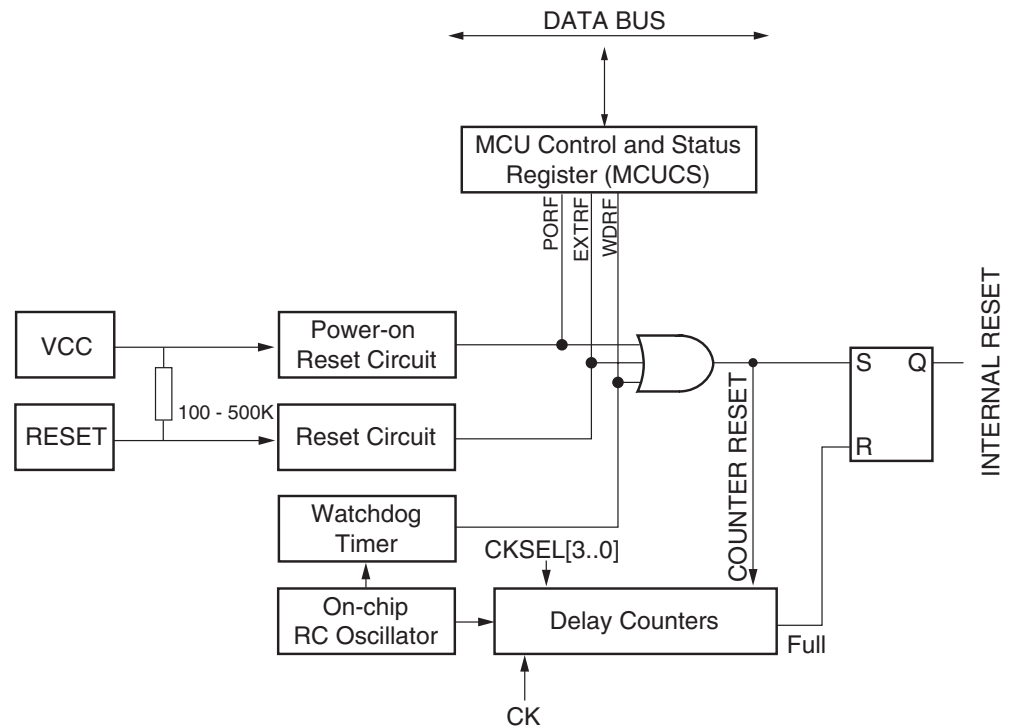
### Reset Sources

The ATTiny28 provides three sources of reset:

- Power-on Reset. The MCU is reset when the supply voltage is below the Power-on Reset threshold ( $V_{POT}$ ).
- External Reset. The MCU is reset when a low level is present on the  $\overline{RESET}$  pin for more than 50 ns.
- Watchdog Reset. The MCU is reset when the Watchdog Timer period expires and the Watchdog is enabled.

During reset, all I/O registers are then set to their initial values and the program starts execution from address \$000. The instruction placed in address \$000 must be an RJMP (relative jump) instruction to the reset handling routine. If the program never enables an interrupt source, the interrupt vectors are not used, and regular program code can be placed at these locations. The circuit diagram in Figure 16 shows the reset logic. Table 4 defines the timing and electrical parameters of the reset circuitry.

**Figure 16.** Reset Logic



**Table 4.** Reset Characteristics

Symbol	Parameter	Min	Typ	Max	Unit
$V_{POT}^{(1)}$	Power-on Reset Threshold Voltage (rising)	1.0	1.4	1.8	V
	Power-on Reset Threshold Voltage (falling)	0.4	0.6	0.8	V
$V_{RST}$	$\overline{RESET}$ Pin Threshold Voltage		$0.6 V_{CC}$		V

Note: 1. The Power-on Reset will not work unless the supply voltage has been below  $V_{POT}$  (falling).

**Table 5.** ATtiny28 Clock Options and Start-up Time

CKSEL3..0	Clock Source	Start-up Time at 2.7V
1111	External Crystal/Ceramic Resonator <sup>(1)</sup>	1K CK
1110	External Crystal/Ceramic Resonator <sup>(1)</sup>	4.2 ms + 1K CK
1101	External Crystal/Ceramic Resonator <sup>(1)</sup>	67 ms + 1K CK
1100	External Crystal/Ceramic Resonator	16K CK
1011	External Crystal/Ceramic Resonator	4.2 ms + 16K CK
1010	External Crystal/Ceramic Resonator	67 ms + 16K CK
1001	External Low-frequency Crystal	67 ms + 1K CK
1000	External Low-frequency Crystal	67 ms + 32K CK
0111	External RC Oscillator	6 CK
0110	External RC Oscillator	4.2 ms + 6 CK
0101	External RC Oscillator	67 ms + 6 CK
0100	Internal RC Oscillator	6 CK
0011	Internal RC Oscillator	4.2 ms + 6 CK
0010	Internal RC Oscillator	67 ms + 6 CK
0001	External Clock	6 CK
0000	External Clock	4.2 ms + 6 CK

Note: 1. Due to limited number of clock cycles in the start-up period, it is recommended that ceramic resonator be used.

This table shows the start-up times from reset. From Power-down mode, only the clock counting part of the start-up time is used. The Watchdog oscillator is used for timing the real-time part of the start-up time. The number WDT oscillator cycles used for each time-out is shown in Table 6.

**Table 6.** Number of Watchdog Oscillator Cycles

Time-out	Number of Cycles
4.2 ms	1K
67 ms	16K

The frequency of the Watchdog oscillator is voltage-dependent, as shown in the section “Typical Characteristics” on page 57.

The device is shipped with CKSEL = 0010.

## Power-on Reset

A Power-on Reset (POR) pulse is generated by an on-chip detection circuit. The detection level is nominally 1.4V. The POR is activated whenever  $V_{CC}$  is below the detection level. The POR circuit can be used to trigger the start-up reset, as well as detect a failure in supply voltage.

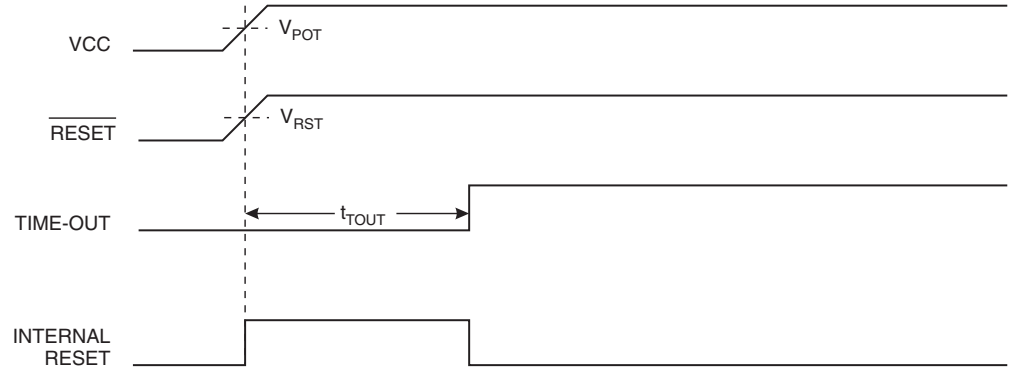
The Power-on Reset (POR) circuit ensures that the device is reset from power-on. Reaching the Power-on Reset threshold voltage invokes a delay counter, which determines the delay for which the device is kept in RESET after  $V_{CC}$  rise. The time-out period of the delay counter can be defined by the user through the CKSEL fuses. The different selections for the delay period are presented in Table 5. The RESET signal is



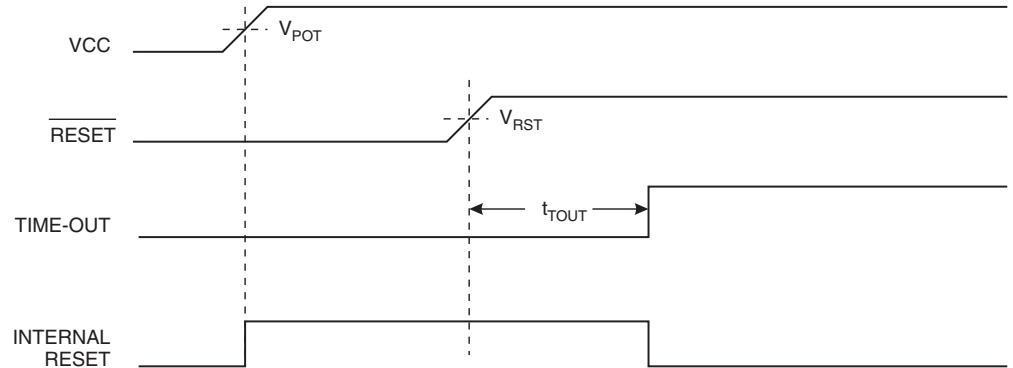
activated again, without any delay, when the  $V_{CC}$  decreases below detection level. See Figure 17.

If the built-in start-up delay is sufficient,  $\overline{\text{RESET}}$  can be connected to  $V_{CC}$  directly or via an external pull-up resistor. By holding the  $\overline{\text{RESET}}$  pin low for a period after  $V_{CC}$  has been applied, the Power-on Reset period can be extended. Refer to Figure 18 for a timing example of this.

**Figure 17.** MCU Start-up,  $\overline{\text{RESET}}$  Tied to  $V_{CC}$ .



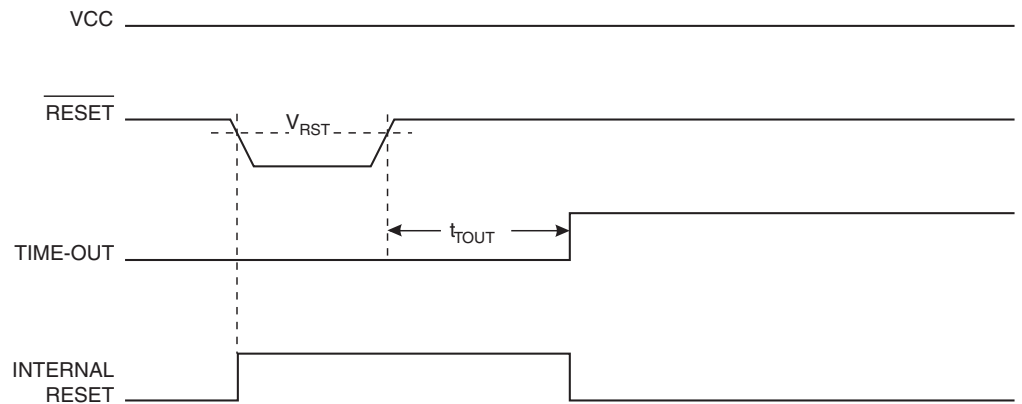
**Figure 18.** MCU Start-up,  $\overline{\text{RESET}}$  Controlled Externally



## External Reset

An external reset is generated by a low level on the  $\overline{\text{RESET}}$  pin. Reset pulses longer than 50 ns will generate a reset, even if the clock is not running. Shorter pulses are not guaranteed to generate a reset. When the applied voltage reaches the Reset Threshold Voltage ( $V_{RST}$ ) on its positive edge, the delay timer starts the MCU after the Time-out period ( $t_{TOUT}$ ) has expired.

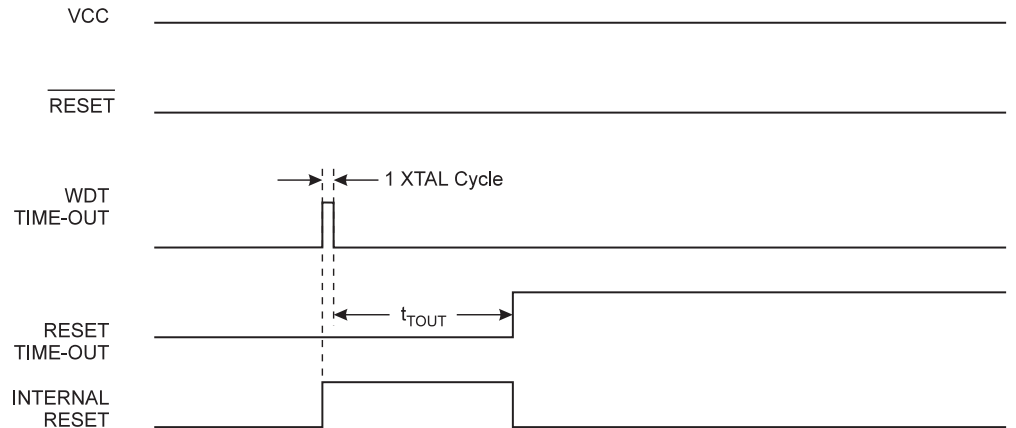
**Figure 19.** External Reset during Operation



**Watchdog Reset**

When the Watchdog times out, it will generate a short reset pulse of 1 XTAL cycle duration. On the falling edge of this pulse, the delay timer starts counting the Time-out period ( $t_{TOUT}$ ). Refer to page 37 for details on operation of the Watchdog.

**Figure 20.** Watchdog Reset during Operation



## Register Description

### MCU Control and Status Register – MCUCS

The MCU Control and Status Register contains control and status bits for general MCU functions.

Bit	7	6	5	4	3	2	1	0	
\$07	<b>PLUPB</b>	–	<b>SE</b>	<b>SM</b>	<b>WDRF</b>	–	<b>EXTRF</b>	<b>PORF</b>	MCUCS
Read/Write	R/W	R	R/W	R/W	R/W	R	R/W	R/W	
Initial Value	0	0	0	0	See Bit Desc.	0	See Bit Description		

- **Bit 7 – PLUPB: Pull-up Enable Port B**

When the PLUPB bit is set (one), pull-up resistors are enabled on all Port B input pins. When PLUPB is cleared, the pull-ups are disabled. If any of the special functions of Port B is enabled, the corresponding pull-up(s) is disabled, independent of the value of PLUPB.

- **Bit 6 – Res: Reserved Bit**

This bit is a reserved bit in the ATTiny28 and always reads as zero.

- **Bit 5 – SE: Sleep Enable**

The SE bit must be set (one) to make the MCU enter the sleep mode when the SLEEP instruction is executed. To avoid the MCU entering the sleep mode unless it is the programmer's purpose, it is recommended to set the Sleep Enable SE bit just before the execution of the SLEEP instruction.

- **Bit 4 – SM: Sleep Mode**

This bit selects between the two available sleep modes. When SM is cleared (zero), Idle Mode is selected as sleep mode. When SM is set (one), Power-down mode is selected as sleep mode. For details, refer to "Sleep Modes" below.

- **Bit 3 – WDRF: Watchdog Reset Flag**

This bit is set if a Watchdog reset occurs. The bit is cleared by a Power-on Reset, or by writing a logical "0" to the flag.

- **Bit 2 – Res: Reserved Bit**

This bit is a reserved bit in the ATTiny28 and always reads as zero.

- **Bit 1 – EXTRF: External Reset Flag**

This bit is set if an external reset occurs. The bit is cleared by a Power-on Reset, or by writing a logical "0" to the flag.

- **Bit 0 – PORF: Power-on Reset Flag**

This bit is set if a Power-on Reset occurs. The bit is cleared by writing a logical "0" to the flag.

To make use of the reset flags to identify a reset condition, the user should read and then clear the flag bits in MCUCS as early as possible in the program. If the register is cleared before another reset occurs, the source of the reset can be found by examining the reset flags.

## Interrupts

### Reset and Interrupt

The ATtiny28 provides five different interrupt sources. These interrupts and the reset vector each have a separate program vector in the program memory space. All the interrupts are assigned to individual enable bits. In order to enable the interrupt, both the individual enable bit and the I-bit in the status register (SREG) must be set to one.

The lowest addresses in the program memory space are automatically defined as the Reset and Interrupt vectors. The complete list of vectors is shown in Table 7. The list also determines the priority levels of the different interrupts. The lower the address, the higher the priority level. RESET has the highest priority, and next is INTO – the External Interrupt Request 0.

**Table 7.** Reset and Interrupt Vectors

Vector No.	Program Address	Source	Interrupt Definition
1	\$000	RESET	Hardware Pin, Power-on Reset and Watchdog Reset
2	\$001	INT0	External Interrupt Request 0
3	\$002	INT1	External Interrupt Request 1
4	\$003	Input Pins	Low-level Input on Port B
5	\$004	TIMER0, OVFO	Timer/Counter0 Overflow
6	\$005	ANA_COMP	Analog Comparator

The most typical and general program setup for the Reset and Interrupt vector addresses are:

```

Address  Labels  Code           Comments
$000          rjmp    RESET      ; Reset handler
$001          rjmp    EXT_INT0   ; IRQ0 handler
$002          rjmp    EXT_INT1   ; IRQ1 handler
$003          rjmp    LOW_LEVEL  ; Low level input handler
$004          rjmp    TIM0_OVF   ; Timer0 overflow handle
$005          rjmp    ANA_COMP   ; Analog Comparator handle
;
$006  MAIN:  <instr> xxx      ; Main program start
...      ...      ...      ...

```

### Interrupt Handling

The ATtiny28 has one 8-bit Interrupt Control Register (ICR).

When an interrupt occurs, the Global Interrupt Enable I-bit is cleared (zero) and all interrupts are disabled. The user software can set (one) the I-bit to enable nested interrupts. The I-bit is set (one) when a Return from Interrupt instruction (RETI) is executed.

When the program counter is vectored to the actual interrupt vector in order to execute the interrupt handling routine, hardware clears the corresponding flag that generated the interrupt. Some of the interrupt flags can also be cleared by writing a logical “1” to the flag bit position(s) to be cleared.

If an interrupt condition occurs when the corresponding interrupt enable bit is cleared (zero), the interrupt flag will be set and remembered until the interrupt is enabled or the flag is cleared by software.

If one or more interrupt conditions occur when the global interrupt enable bit is cleared (zero), the corresponding interrupt flag(s) will be set and remembered until the global interrupt enable bit is set (one), and will be executed by order of priority.

Note that external level interrupt does not have a flag and will only be remembered for as long as the interrupt condition is active.

Note that the status register is not automatically stored when entering an interrupt routine and restored when returning from an interrupt routine. This must be handled by software.

### **Interrupt Response Time**

The interrupt execution response for all the enabled AVR interrupts is four clock cycles minimum. After four clock cycles the program vector address for the actual interrupt handling routine is executed. During this 4-clock-cycle period, the program counter (10 bits) is pushed onto the stack. The vector is normally a relative jump to the interrupt routine, and this jump takes two clock cycles. If an interrupt occurs during execution of a multi-cycle instruction, this instruction is completed before the interrupt is served. If an interrupt occurs when the MCU is in sleep mode, the interrupt execution response time is increased by four clock cycles.

A return from an interrupt handling routine takes four clock cycles. During these four clock cycles, the program counter (10 bits) is popped back from the stack, and the I-flag in SREG is set. When AVR exits from an interrupt, it will always return to the main program and execute one more instruction before any pending interrupt is served.

### **External Interrupt**

The external interrupt is triggered by the INT pins. Observe that, if enabled, the interrupt will trigger even if the INT pin is configured as an output. This feature provides a way of generating a software interrupt. The external interrupt can be triggered by a falling or rising edge, a pin change or a low level. This is set up as indicated in the specification for the Interrupt Control Register (ICR). When the external interrupt is enabled and is configured as level-triggered, the interrupt will trigger as long as the pin is held low.

The external interrupt is set up as described in the specification for the Interrupt Control Register (ICR).

### **Low-level Input Interrupt**

The low-level interrupt is triggered by setting any of the Port B pins low. However, if any Port B pins are used for other special features, these pins will not trigger the interrupt. For example, if the analog comparator is enabled, a low level on PB0 or PB1 will not cause an interrupt. This is also the case for the special functions T0, INT0 and INT1. If low-level interrupt is selected, the low level must be held until the completion of the currently executing instruction to generate an interrupt. When this interrupt is enabled, the interrupt will trigger as long as any of the Port B pins are held low.

## Register Description

### Interrupt Control Register – ICR

Bit	7	6	5	4	3	2	1	0	
\$06	INT1	INT0	LLIE	TOIE0	ISC11	ISC10	ISC01	ISC00	ICR
Read/Write	R/W	R/W	R/W	R/W	R/W	R/W	R/W	R/W	
Initial Value	0	0	0	0	0	0	0	0	

- **Bit 7 – INT1: External Interrupt Request 1 Enable**

When the INT1 bit is set (one) and I-bit in the Status Register (SREG) is set (one), the external pin interrupt 1 is enabled. The interrupt Sense Control1 bits 1/0 (ISC11 and ISC10) define whether the external interrupt is activated on rising or falling edge, on pin change or low level of the INT1 pin. The corresponding interrupt of External Interrupt Request 1 is executed from program memory address \$002. See also “External Interrupt”.

- **Bit 6 – INT0: External Interrupt Request 0 Enable**

When the INT0 bit is set (one) and the I-bit in the Status Register (SREG) is set (one), the external pin interrupt 0 is enabled. The interrupt Sense Control0 bits 1/0 (ISC01 and ISC00) define whether the external interrupt is activated on rising or falling edge, on pin change or low level of the INT0 pin. The corresponding interrupt of External Interrupt Request 0 is executed from program memory address \$001. See also “External Interrupt”.

- **Bit 5 – LLIE: Low-level Input Interrupt Enable**

When the LLIE is set (one) and the I-bit in the status register (SREG) is set (one), the interrupt on low-level input is activated. Any of the Port B pins pulled low will then cause an interrupt. However, if any Port B pins are used for other special features, these pins will not trigger the interrupt. The corresponding interrupt of Low-level Input Interrupt Request is executed from program memory address \$003. See also “Low-level Input Interrupt”.

- **Bit 4 – TOIE0: Timer/Counter0 Overflow Interrupt Enable**

When the TOIE0 bit is set (one) and the I-bit in the Status Register is set (one), the Timer/Counter0 Overflow Interrupt is enabled. The corresponding interrupt (at vector \$004) is executed if an overflow in Timer/Counter0 occurs, i.e., when the TOV0 bit is set in the Interrupt Flag Register (IFR).

- **Bits 3, 2 – ISC11, ISC10: Interrupt Sense Control 1 Bit 1 and Bit 0**

The External Interrupt 1 is activated by the external pin INT1 if the SREG I-flag and the corresponding interrupt enable are set. The level and edges on the external INT1 pin that activate the interrupt are defined in Table 8.

**Table 8.** Interrupt 1 Sense Control

ISC11	ISC10	Description
0	0	The low level of INT1 generates an interrupt request.
0	1	Any change on INT1 generates an interrupt request.
1	0	The falling edge of INT1 generates an interrupt request.
1	1	The rising edge of INT1 generates an interrupt request.

Note: When changing the ISC11/ISC10 bits, INT1 must be disabled by clearing its Interrupt Enable bit. Otherwise, an interrupt can occur when the bits are changed.

• **Bits 1, 0 – ISC01, ISC00: Interrupt Sense Control 0 Bit 1 and Bit 0**

The External Interrupt 0 is activated by the external pin INT0 if the SREG I-flag and the corresponding interrupt enable are set. The level and edges on the external INT0 pin that activate the interrupt are defined in Table 9.

**Table 9.** Interrupt 0 Sense Control

ISC01	ISC00	Description
0	0	The low level of INT0 generates an interrupt request.
0	1	Any change on INT0 generates an interrupt request.
1	0	The falling edge of INT0 generates an interrupt request.
1	1	The rising edge of INT0 generates an interrupt request.

Note: When changing the ISC01/ISC00 bits, INT0 must be disabled by clearing its Interrupt Enable bit. Otherwise, an interrupt can occur when the bits are changed.

The value on the INT pins are sampled before detecting edges. If edge interrupt is selected, pulses that last longer than one CPU clock period will generate an interrupt. Shorter pulses are not guaranteed to generate an interrupt. If low-level interrupt is selected, the low level must be held until the completion of the currently executing instruction to generate an interrupt. If enabled, a level-triggered interrupt will generate an interrupt request as long as the pin is held low.

## Interrupt Flag Register – IFR

Bit	7	6	5	4	3	2	1	0	
\$05	<b>INTF1</b>	<b>INTF0</b>	–	<b>TOV0</b>	–	–	–	–	<b>IFR</b>
Read/Write	R/W	R/W	R	R/W	R	R	R	R	
Initial Value	0	0	0	0	0	0	0	0	

• **Bit 7 – INTF1: External Interrupt Flag1**

When an edge on the INT1 pin triggers an interrupt request, the corresponding interrupt flag, INTF1 becomes set (one). If the I-bit in SREG and the corresponding interrupt enable bit, INT1 in GIMSK is set (one), the MCU will jump to the interrupt vector. The flag is cleared when the interrupt routine is executed. Alternatively, the flag can be cleared by writing a logical “1” to it. This flag is always cleared when INT1 is configured as level interrupt.

• **Bit 6 – INTF0: External Interrupt Flag0**

When an edge on the INT0 pin triggers an interrupt request, the corresponding interrupt flag, INTF0 becomes set (one). If the I-bit in SREG and the corresponding interrupt

enable bit, INT0 in GIMSK is set (one), the MCU will jump to the interrupt vector. The flag is cleared when the interrupt routine is executed. Alternatively, the flag can be cleared by writing a logical “1” to it. This flag is always cleared when INT0 is configured as level interrupt.

- **Bit 5 – Res: Reserved Bit**

This bit is a reserved bit in the ATtiny28 and always reads as zero.

- **Bit 4 – TOV0: Timer/Counter0 Overflow Flag**

The bit TOV0 is set (one) when an overflow occurs in Timer/Counter0. TOV0 is cleared by hardware when executing the corresponding interrupt handling vector. TOV0 is cleared by writing a logical “1” to the flag. When the SREG I-bit, TOIE0 in ICR and TOV0 are set (one), the Timer/Counter0 Overflow interrupt is executed.

- **Bit 3..0 - Res: Reserved Bits**

These bits are reserved bits in the ATtiny28 and always read as zero.

Note: 1. One should not try to use the SBI (Set Bit in I/O Register) instruction to clear individual flags in the Register. This will result in clearing all the flags in the register, because the register is first read, then modified and finally written, thus writing ones to all set flags. Using the CBI (Clear Bit in I/O Register) instruction on IFR will result in clearing all bits apart from the specified bit.



## I/O Ports

All AVR ports have true read-modify-write functionality when used as general digital I/O ports. This means that the direction of one port pin can be changed without unintentionally changing the direction of any other pin with the SBI and CBI instructions. The same applies for changing drive value (if configured as output) or enabling/disabling of pull-up resistors (if configured as input).

## Port A

Port A is a 4-bit I/O port. PA3, PA1, and PA0 are bi-directional, while PA2 is output-only. Before entering Power-down, see “Sleep Modes” on page 14, PORTA2 bit in PORTA register should be set.

Three I/O memory address locations are allocated for Port A, one each for the Data Register – PORTA, \$1B, Port A Control Register – PACR, \$1A and the Port A Input Pins – PINA, \$19. The Port A Input Pins address is read-only, while the Data Register and the Control Register are read/write. Compared to other output ports, the Port A output is delayed one extra clock cycle.

Port pins PA0, PA1 and PA3 have individually selectable pull-up resistors. When pins PA0, PA1 or PA3 are used as inputs and are externally pulled low, they will source current if the internal pull-up resistors are activated. PA2 is output-only. The PA2 output buffer can sink 25 mA and thus drive a high-current LED directly. This output can also be modulated (see “Hardware Modulator” on page 39 for details).

## Port A as General Digital I/O

PA3, PA1 and PA0 are general I/O pins. The DDAn (n: 3,1,0) bits in PACR select the direction of these pins. If DDAn is set (one), PAn is configured as an output pin. If DDAn is cleared (zero), PAn is configured as an input pin. If PORTAn is set (one) when the pin is configured as an input pin, the MOS pull-up resistor is activated. To switch the pull-up resistor off, the PORTAn bit has to be cleared (zero) or the pin has to be configured as an output pin. The effects of the DDAn and PORTAn bits on PA3, PA1 and PA0 are shown in Table 10. The port pins are tri-stated when a reset condition becomes active, even if the clock is not running.

**Table 10.** DDAn Effects on Port A Pins

DDAn	PORTAn	I/O	Pull-up	Comment
0	0	Input	No	Tri-state (high-Z)
0	1	Input	Yes	PAn will source current if ext. pulled low.
1	0	Output	No	Push-pull Zero Output
1	1	Output	No	Push-pull One Output

Note: n: 3,1,0, pin number

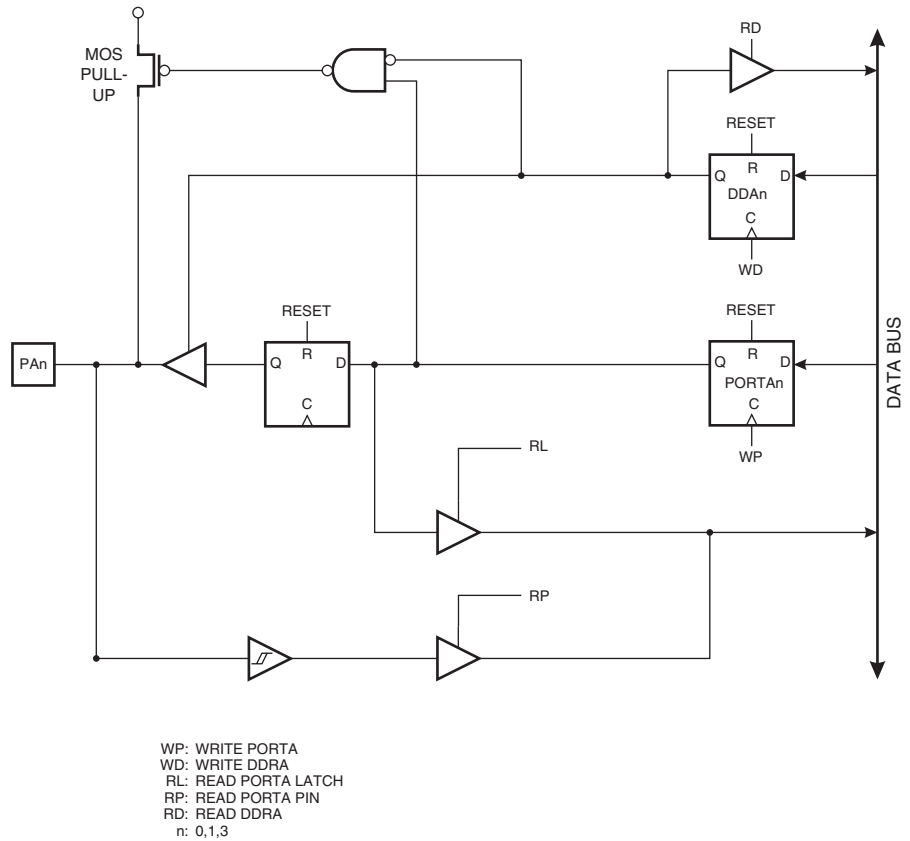
## Alternate Function of PA2

PA2 is the built-in, high-current LED driver and it is always an output pin. The output signal can be modulated with a software programmable frequency. See “Hardware Modulator” on page 39 for further details.

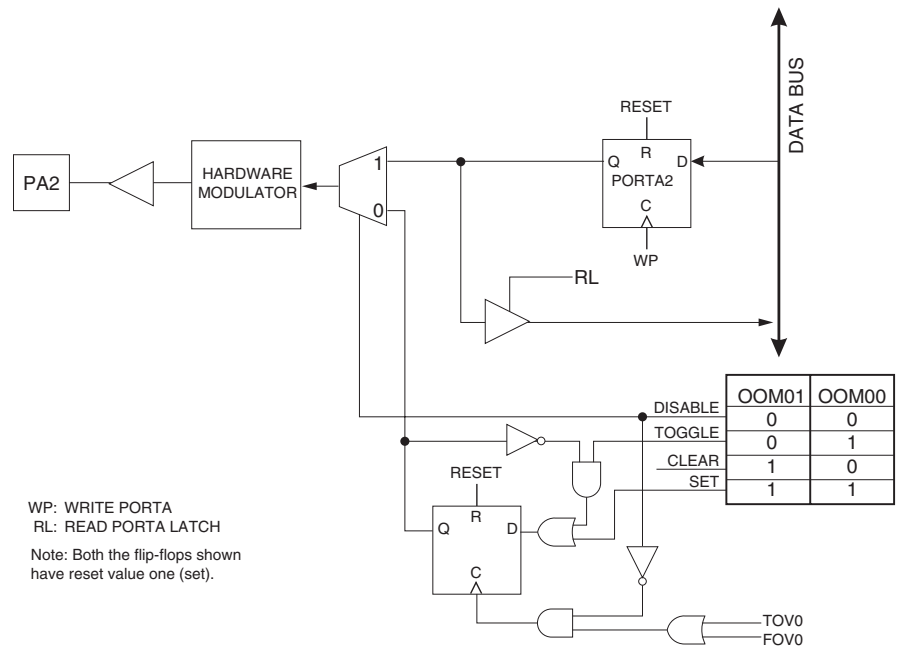
## Port A Schematics

Note that all port pins are synchronized. The synchronization latches are, however, not shown in the figures.

**Figure 21.** Port A Schematic Diagram (Pins PA0, PA1 and PA3)



**Figure 22.** Port A Schematic Diagram (Pin PA2)



## Port B

Port B is an 8-bit input port.

One I/O address location is allocated for the Port B Input Pins – PINB, \$16. The Port B Input Pins address is read-only.

All port pins have pull-ups that can be switched on for all Port B pins simultaneously. If any of the Port B special functions is enabled, the corresponding pull-up(s) is disabled. When pins PB0 to PB7 are externally pulled low, they will source current ( $I_{IL}$ ) if the internal pull-up resistors are activated.

The Port B pins with alternate functions are shown in Table 11.

**Table 11.** Port B Pin Alternate Functions

Port Pin	Alternate Functions
PB0	AIN0 (Analog Comparator Positive Input)
PB1	AIN1 (Analog Comparator Negative Input)
PB2	T0 (Timer/Counter 0 External Counter Input)
PB3	INT0 (External Interrupt 0 Input)
PB4	INT1 (External Interrupt 1 Input)

**Port B as General Digital Input** All eight pins in Port B have equal functionality when used as digital input pins.

PB<sub>n</sub>, general input pin: To switch the pull-up resistors on, the PLUPB bit in the MCUCS register must be set (one). This bit controls the pull-up on all Port B pins. To turn the pull-ups off, this bit has to be cleared (zero). Note that if any Port B pins are used for alternate functions, the pull-up on the corresponding pins are disabled. The port pins are tri-stated when a reset condition becomes active, even if the clock is not running.

## Alternate Functions of Port B

All Port B pins are connected to a low-level detector that can trigger the low-level input interrupt. See “Low-level Input Interrupt” on page 21 for details. In addition, Port B has the following alternate functions:

- **INT1 – Port B, Bit 4**

INT1, External Interrupt source 1. The PB4 pin can serve as an external interrupt source to the MCU. See the interrupt description for details on how to enable and configure this interrupt. If the interrupt is enabled, the pull-up resistor on PB4 is disabled and PB4 will not give low-level interrupts.

- **INT0 – Port B, Bit 3**

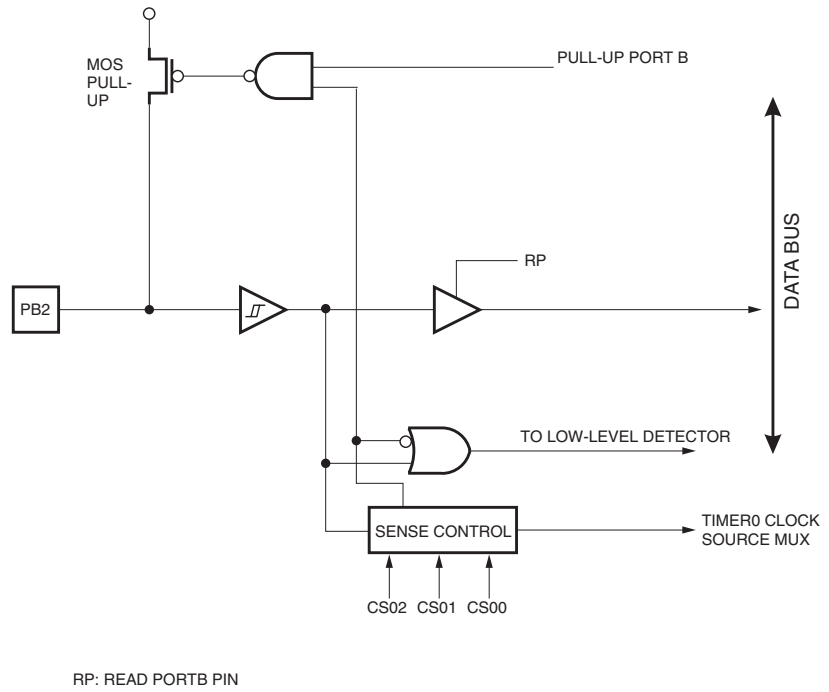
INT0, External Interrupt source 0. The PB3 pin can serve as an external interrupt source to the MCU. See the interrupt description for details on how to enable and configure this interrupt. If the interrupt is enabled, the pull-up resistor on PB3 is disabled and PB3 will not give low-level interrupts.

- **T0 – Port B, Bit 2**

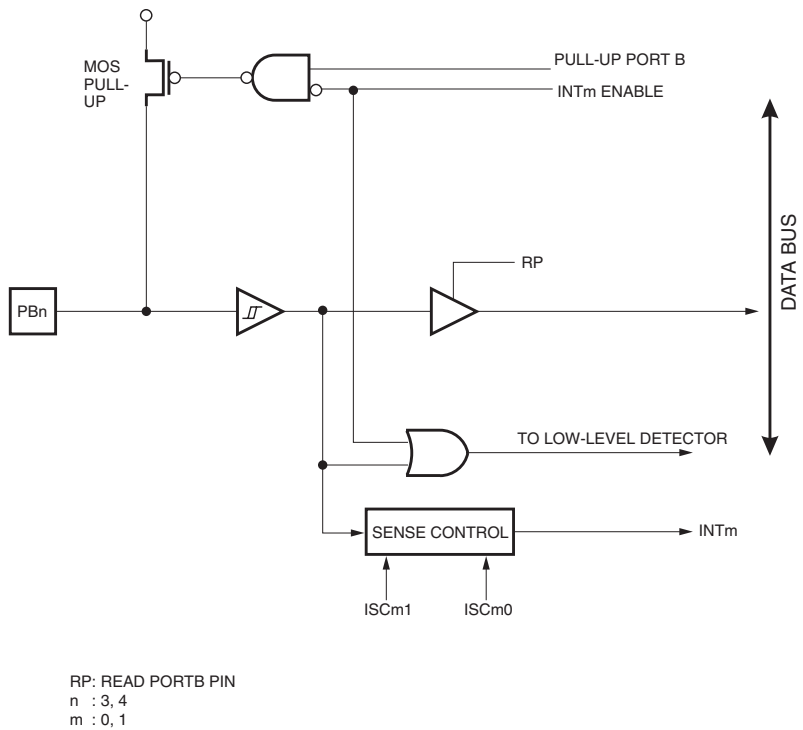
T0, Timer/Counter0 Counter source. See the timer description for further details. If T0 is used as the counter source, the pull-up resistor on PB2 is disabled and PB2 will not give low-level interrupts.



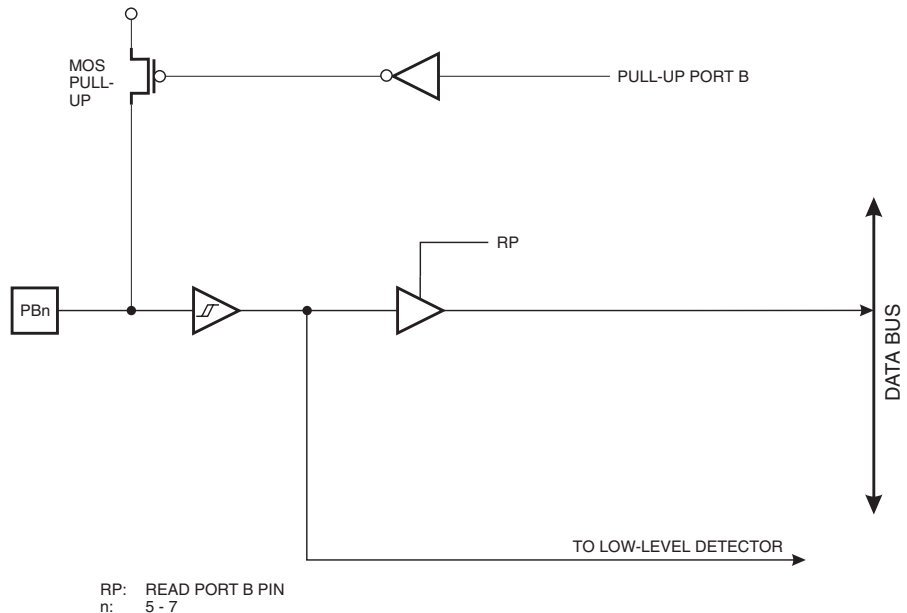
**Figure 24.** Port B Schematic Diagram (Pin PB2)



**Figure 25.** PORT B Schematic Diagram (Pins PB3 and PB4)



**Figure 26.** PORT B Schematic Diagram (Pins PB7 - PB5)



## Port D

Port D is an 8-bit bi-directional I/O port with internal pull-up resistors.

Three I/O memory address locations are allocated for Port D, one each for the Data Register – PORTD, \$12, Data Direction Register – DDRD, \$11 and the Port D Input Pins – PIND, \$10. The Port D Input Pins address is read-only, while the Data Register and the Data Direction Register are read/write.

The Port D output buffers can sink 10 mA. As inputs, Port D pins that are externally pulled low will source current if the pull-up resistors are activated.

## Port D as General Digital I/O

All eight pins in Port D have equal functionality when used as digital I/O pins.

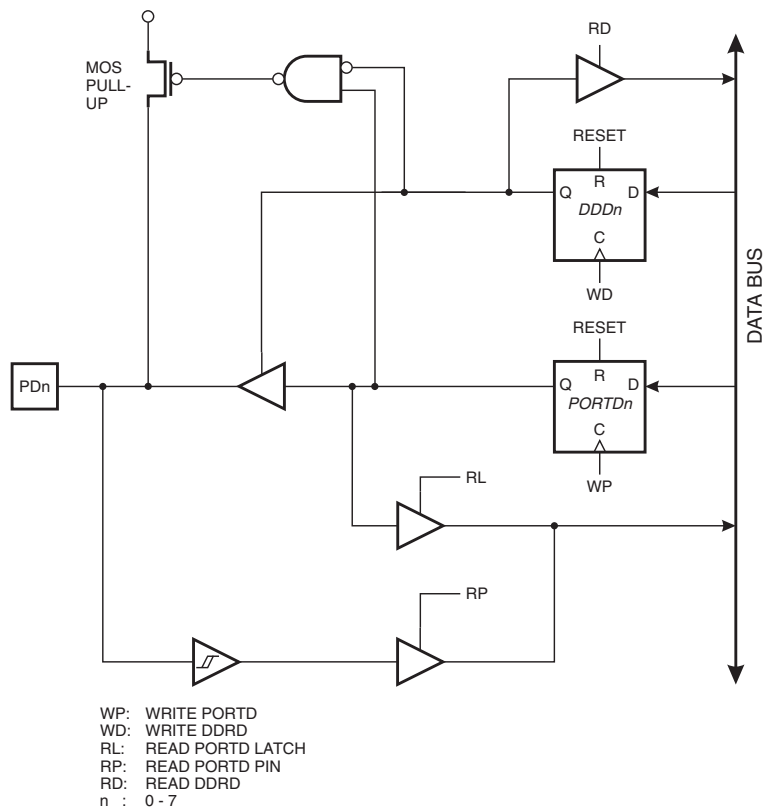
PD<sub>n</sub>, general I/O pin: The DDD<sub>n</sub> bit in the DDRD register selects the direction of this pin. If DDD<sub>n</sub> is set (one), PD<sub>n</sub> is configured as an output pin. If DDD<sub>n</sub> is cleared (zero), PD<sub>n</sub> is configured as an input pin. If PD<sub>n</sub> is set (one) when configured as an input pin, the MOS pull-up resistor is activated. To switch the pull-up resistor off, the PD<sub>n</sub> has to be cleared (zero), or the pin has to be configured as an output pin. The port pins are tri-stated when a reset condition becomes active, even if the clock is not running.

**Table 12.** DDD<sub>n</sub> Bits on Port D Pins

DDD <sub>n</sub>	PORTD <sub>n</sub>	I/O	Pull-up	Comment
0	0	Input	No	Tri-state (high-Z)
0	1	Input	Yes	PD <sub>n</sub> will source current if ext. pulled low
1	0	Output	No	Push-pull Zero Output
1	1	Output	NO	Push-pull One Output

Note: n: 7,6,...,0, pin number

**Figure 27.** Port D Schematic Diagram (Pins PD7 - PD0)



## Register Description

### Port A Data Register – PORTA

Bit	7	6	5	4	3	2	1	0	
\$1B	–	–	–	–	PORTA3	PORTA2	PORTA1	PORTA0	PORTA
Read/Write	R	R	R	R	R/W	R/W	R/W	R/W	
Initial Value	0	0	0	0	0	1	0	0	

### Port A Control Register – PACR

Bit	7	6	5	4	3	2	1	0	
\$1A	–	–	–	–	DDA3	PA2HC	DDA1	DDA0	PACR
Read/Write	R	R	R	R	R/W	R/W	R/W	R/W	
Initial Value	0	0	0	0	0	0	0	0	

- **Bits 7..4 – Res: Reserved Bits**

These bits are reserved bits in the ATtiny28 and always read as zero.

- **Bit 3 – DDA3: Data Direction PA3**

When DDA3 is set (one), the corresponding pin is an output pin. Otherwise, it is an input pin.

- **Bit 2 – PA2HC: PORTA2 High Current Enable**

When the PA2HC bit is set (one), an additional driver at the output pin PA2 is enabled. This makes it possible to sink 25 mA at  $V_{CC} = 1.8V$  ( $V_{OL} = 0.8V$ ). When the PA2HC bit is cleared (zero), PA2 can sink 15 mA at  $V_{CC} = 1.8V$  ( $V_{OL} = 0.8V$ ).

- **Bits 1, 0 – DDA1, DDA0: Data Direction PA1 and PA0**

When DDAn is set (one), the corresponding pin is an output pin. Otherwise, it is an input pin.

### Port A Input Pins Address – PINA

Bit	7	6	5	4	3	2	1	0	
\$19	–	–	–	–	PINA3	–	PINA1	PINA0	PINA
Read/Write	R	R	R	R	R	R	R	R	
Initial Value	0	0	0	0	N/A	0	N/A	N/A	

The Port A Input Pins address (PINA) is not a register; this address enables access to the physical value on each Port A pin. When reading PORTA, the Port A Data Latch is read and when reading PINA, the logical values present on the pins are read.

### Port B Input Pins Address – PINB

Bit	7	6	5	4	3	2	1	0	
\$16	PINB7	PINB6	PINB5	PINB4	PINB3	PINB2	PINB1	PINB0	PINB
Read/Write	R	R	R	R	R	R	R	R	
Initial Value	N/A	N/A	N/A	N/A	N/A	N/A	N/A	N/A	

The Port B Input Pins address (PINB) is not a register; this address enables access to the physical value on each Port B pin. When reading PINB, the logical values present on the pins are read.



## Port D Data Register – PORTD

Bit	7	6	5	4	3	2	1	0	
\$12	<b>PORTD7</b>	<b>PORTD6</b>	<b>PORTD5</b>	<b>PORTD4</b>	<b>PORTD3</b>	<b>PORTD2</b>	<b>PORTD1</b>	<b>PORTD0</b>	PORTD
Read/Write	R/W	R/W	R/W	R/W	R/W	R/W	R/W	R/W	
Initial Value	0	0	0	0	0	0	0	0	

## Port D Data Direction Register – DDRD

Bit	7	6	5	4	3	2	1	0	
\$11	<b>DDD7</b>	<b>DDD6</b>	<b>DDD5</b>	<b>DDD4</b>	<b>DDD3</b>	<b>DDD2</b>	<b>DDD1</b>	<b>DDD0</b>	DDRD
Read/Write	R/W	R/W	R/W	R/W	R/W	R/W	R/W	R/W	
Initial Value	0	0	0	0	0	0	0	0	

## Port D Input Pins Address – PIND

Bit	7	6	5	4	3	2	1	0	
\$10	<b>PIND7</b>	<b>PIND6</b>	<b>PIND5</b>	<b>PIND4</b>	<b>PIND3</b>	<b>PIND2</b>	<b>PIND1</b>	<b>PIND0</b>	PIND
Read/Write	R	R	R	R	R	R	R	R	
Initial Value	N/A	N/A	N/A	N/A	N/A	N/A	N/A	N/A	

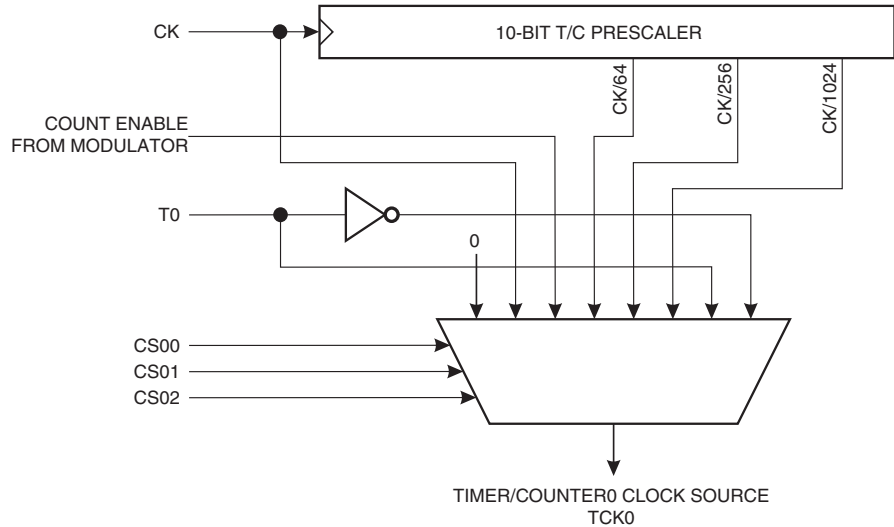
The Port D Input Pins Address (PIND) is not a register; this address enables access to the physical value on each Port D pin. When reading PORTD, the Port D Data Latch is read and when reading PIND, the logical values present on the pins are read.

## Timer/Counter0

The ATtiny28 provides one general-purpose 8-bit Timer/Counter – Timer/Counter0. Timer/Counter0 has prescaling selection from the 10-bit prescaling timer. The Timer/Counter0 can either be used as a timer with an internal clock time base or as a counter with an external pin connection that triggers the counting.

**Timer/Counter Prescaler** Figure 28 shows the Timer/Counter prescaler.

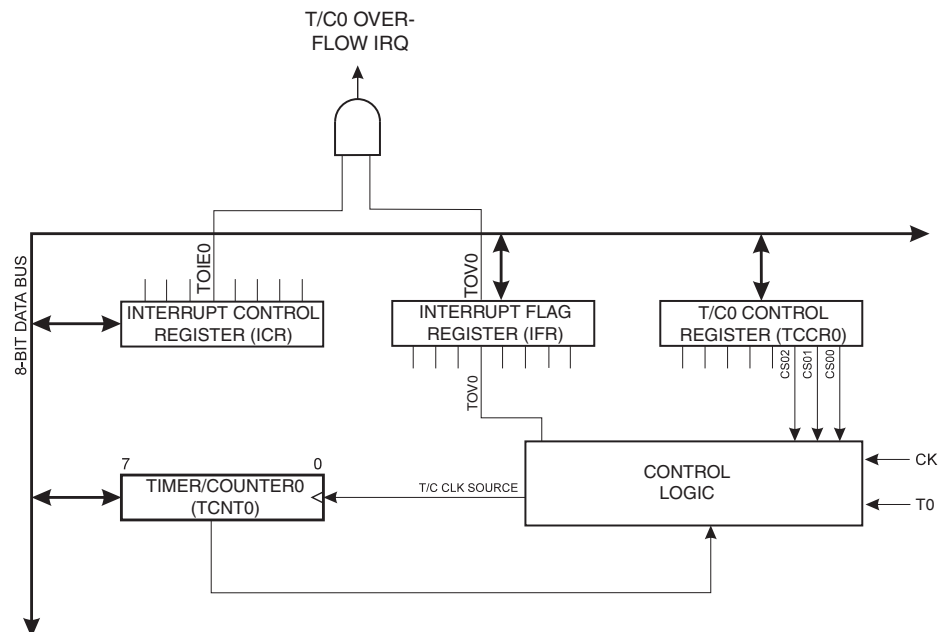
**Figure 28.** Timer/Counter0 Prescaler



The four different prescaled selections are: the hardware modulator period, CK/64, CK/256 and CK/1028, where CK is the oscillator clock. CK, external source and stop can also be selected as clock sources.

Figure 29 shows the block diagram for Timer/Counter0.

**Figure 29.** Timer/Counter0 Block Diagram



The 8-bit Timer/Counter0 can select clock source from CK, prescaled CK or an external pin. In addition, it can be stopped as described in the specification for the Timer/Counter0 Control Register (TCCR0). The overflow status flag is found in the Interrupt Flag Register (IFR). Control signals are found in the Timer/Counter0 Control Register (TCCR0). The interrupt enable/disable setting for Timer/Counter0 is found in the Interrupt Control Register (ICR).

When Timer/Counter0 is externally clocked, the external signal is synchronized with the oscillator frequency of the CPU. To ensure proper sampling of the external clock, the minimum time between two external clock transitions must be at least one internal CPU clock period. The external clock signal is sampled on the rising edge of the internal CPU clock.

The 8-bit Timer/Counter0 features both a high-resolution and a high-accuracy usage with the lower prescaling opportunities. Similarly, the high prescaling opportunities make the Timer/Counter0 useful for lower speed functions or exact timing functions with infrequent actions.

## Register Description

### Timer/Counter0 Control Register – TCCR0

Bit	7	6	5	4	3	2	1	0	
\$04	<b>FOV0</b>	–	–	<b>OOM01</b>	<b>OOM00</b>	<b>CS02</b>	<b>CS01</b>	<b>CS00</b>	TCCR0
Read/Write	R/W	R	R	R/W	R/W	R/W	R/W	R/W	
Initial Value	0	0	0	0	0	0	0	0	

- **Bit 7 – FOV0: Force Overflow**

Writing a logical “1” to this bit forces a change on the overflow output pin PA2 according to the values already set in OOM01 and OOM00. If the OOM01 and OOM00 bits are written in the same cycle as FOV0, the new settings will not take effect until the next overflow or forced overflow occurs. The Force Overflow bit can be used to change the output pin without waiting for an overflow in the timer. The automatic action programmed in OOM01 and OOM00 happens as if an overflow had occurred, but no interrupt is generated. The FOV0 bit will always read as zero, and writing a zero to this bit has no effect.

- **Bits 6, 5 – Res: Reserved Bits**

These bits are reserved bits in the ATtiny28 and always read as zero.

- **Bits 4, 3 – OOM01, OOM00: Overflow Output Mode, Bits 1 and 0**

The OOM01 and OOM00 control bits determine any output pin action following an overflow or a forced overflow in Timer/Counter0. Any output pin actions affect pin PA2. The control configuration is shown in Table 13.

**Table 13.** Overflow Output Mode Select

OOM01	OOM00	Description
0	0	Timer/Counter0 disconnected from output pin PA2
0	1	Toggle the PA2 output line.
1	0	Clear the PA2 output line to zero.
1	1	Set the PA2 output line to one.

• **Bits 2, 1, 0 – CS02, CS01, CS00: Clock Select0, Bits 2, 1 and 0**

The Clock Select0 bits 2, 1 and 0 define the prescaling source of Timer/Counter0.

**Table 14.** Clock 0 Prescale Select

CS02	CS01	CS00	Description
0	0	0	Stop, the Timer/Counter0 is stopped.
0	0	1	CK
0	1	0	Modulator Period
0	1	1	CK/64
1	0	0	CK/256
1	0	1	CK/1024
1	1	0	External Pin T0, falling edge
1	1	1	External Pin T0, rising edge

The Stop condition provides a Timer Enable/Disable function. The CK down divided modes are scaled directly from the CK oscillator clock. If the external pin modes are used for Timer/Counter0, transitions on PB2/(T0) will clock the counter even if the pin is configured as an output. This feature can give the user software control of the counting.

**Timer Counter 0 – TCNT0**

Bit	7	6	5	4	3	2	1	0		
\$03	<b>MSB</b>							<b>LSB</b>		TCNT0
Read/Write	R/W	R/W	R/W	R/W	R/W	R/W	R/W	R/W		
Initial Value	0	0	0	0	0	0	0	0		

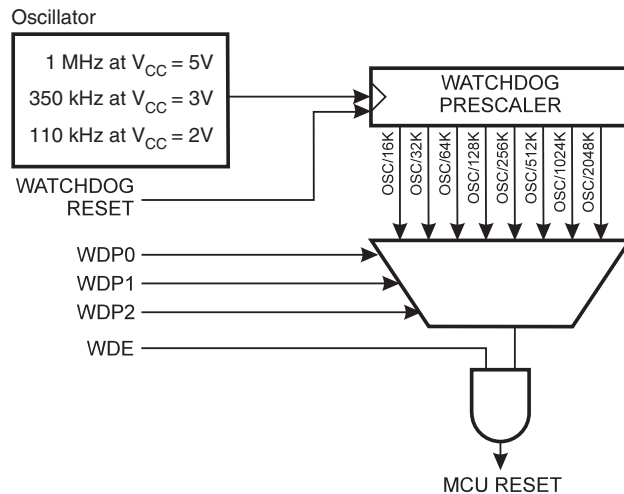
The Timer/Counter0 is realized as an up-counter with read and write access. If the Timer/Counter0 is written and a clock source is present, the Timer/Counter0 continues counting in the timer clock cycle following the write operation.

## Watchdog Timer

The Watchdog Timer is clocked from a separate on-chip oscillator. By controlling the Watchdog Timer prescaler, the Watchdog reset interval can be adjusted as shown in Table 15. See characterization data for typical values at other  $V_{CC}$  levels. The WDR (Watchdog Reset) instruction resets the Watchdog Timer. Eight different clock cycle periods can be selected to determine the reset period. If the reset period expires without another Watchdog reset, the ATtiny28 resets and executes from the reset vector. For timing details on the Watchdog reset, refer to page 18.

To prevent unintentional disabling of the Watchdog, a special turn-off sequence must be followed when the Watchdog is disabled. Refer to the description of the Watchdog Timer Control Register for details.

**Figure 30.** Watchdog Timer



## Register Description

### Watchdog Timer Control Register – WDTCR

Bit	7	6	5	4	3	2	1	0	
\$01	–	–	–	WDTOE	WDE	WDP2	WDP1	WDP0	WDTCR
Read/Write	R	R	R	R/W	R/W	R/W	R/W	R/W	
Initial Value	0	0	0	0	0	0	0	0	

- **Bits 7..5 - Res: Reserved Bits**

These bits are reserved bits in the ATtiny28 and will always read as zero.

- **Bit 4 – WDTOE: Watchdog Turn-off Enable**

This bit must be set (one) when the WDE bit is cleared. Otherwise, the Watchdog will not be disabled. Once set, hardware will clear this bit to zero after four clock cycles. Refer to the description of the WDE bit for a Watchdog disable procedure.

- **Bit 3 – WDE: Watchdog Enable**

When the WDE is set (one), the Watchdog Timer is enabled and if the WDE is cleared (zero), the Watchdog Timer function is disabled. WDE can only be cleared if the WDTOE bit is set (one). To disable an enabled Watchdog Timer, the following procedure must be followed:

1. In the same operation, write a logical “1” to WDTOE and WDE. A logical “1” must be written to WDE even though it is set to one before the disable operation starts.
2. Within the next four clock cycles, write a logical “0” to WDE. This disables the Watchdog.

• **Bits 2..0 – WDP2, WDP1, WDP0: Watchdog Timer Prescaler 2, 1 and 0**

The WDP2, WDP1 and WDP0 bits determine the Watchdog Timer prescaling when the Watchdog Timer is enabled. The different prescaling values and their corresponding time-out periods are shown in Table 15.

**Table 15.** Watchdog Timer Prescale Select

WDP2	WDP1	WDP0	Number of WDT Oscillator Cycles	Typical Time-out at $V_{CC} = 2.0V$	Typical Time-out at $V_{CC} = 3.0V$	Typical Time-out at $V_{CC} = 5.0V$
0	0	0	16K cycles	0.15 s	47 ms	15 ms
0	0	1	32K cycles	0.30 s	94 ms	30 ms
0	1	0	64K cycles	0.60 s	0.19 s	60 ms
0	1	1	128K cycles	1.2 s	0.38 s	0.12 s
1	0	0	256K cycles	2.4 s	0.75 s	0.24 s
1	0	1	512K cycles	4.8 s	1.5 s	0.49 s
1	1	0	1,024K cycles	9.6 s	3.0 s	0.97 s
1	1	1	2,048K cycles	19 s	6.0 s	1.9 s

Note: The frequency of the Watchdog oscillator is voltage-dependent, as shown in the section “Typical Characteristics” on page 57.

The WDR (Watchdog Reset) instruction should always be executed before the Watchdog Timer is enabled. This ensures that the reset period will be in accordance with the Watchdog Timer prescale settings. If the Watchdog Timer is enabled without reset, the Watchdog Timer may not start counting from zero.

## Hardware Modulator

ATtiny28 features a built-in hardware modulator connected to a high-current output pad, PA2. The hardware modulator generates a configurable pulse train. The on-time of a pulse can be set to a number of chip clock cycles. This is done by configuring the Modulation Control Register (MODCR).

PA2 is the built-in, high-current LED driver and it is always an output pin. The output buffer can sink 25 mA at  $V_{CC} = 2.0V$ . When MCONF is zero, modulation is switched off and the pin acts as a normal high-current output pin. The following truth table shows the effect of various PORTA2 and MCONF settings.

**Table 16.** PA2 Output

PORTA2	MCONF	PA2 Output
0	0	0
0	1 - 7	Modulated
1	X	1

The modulation period is available as a prescale to Timer/Counter0 and thus, this timer should be used to time the length of each burst. If the number of pulses to be sent is N, the number 255 - N should be loaded to the timer. When an overflow occurs, the transmission is complete. The OOM01 and OOM00 bits in TCCR0 can be configured to automatically change the value on PA2 when a Timer/Counter0 overflow occurs. See "Timer/Counter0" on page 34 for details on how to configure the OOM01 and OOM00 bits.

The modulation period is available as a prescale even when PORTA2 is high and modulation is stopped. Thus, this prescale can also be used to time the intervals between bursts.

To get a glitch-free output, the user should first configure the MODCR register to enable modulation. There are two ways to start the modulation:

1. Clear the PORTA2 bit in Port A Data Register (PORTA).
2. Configure OOM00 and OOM01 bits in the Timer/Counter0 Control Register (TCCR0) to clear PA2 on the next overflow. Either an overflow or a forced overflow can then be used to start modulation.

The PA2 output will then be set low at the start of the next cycle. To stop the modulated output, the user should set the PORTA2 bit or configure OOM00 and OOM01 to set PA2 on the next overflow. If the MODCR register is changed during modulation, the changed value will take effect at the start of the next cycle, producing a glitch-free output. See Figure 31 below and Figure 22 on page 26.

**Figure 31.** The Hardware Modulator

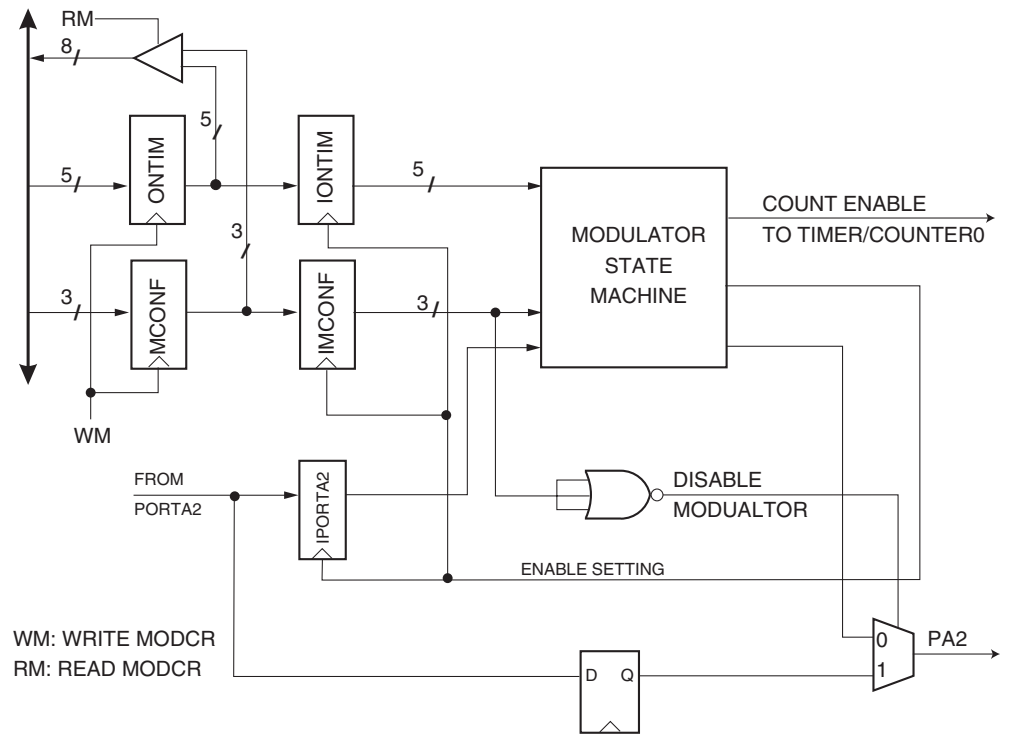
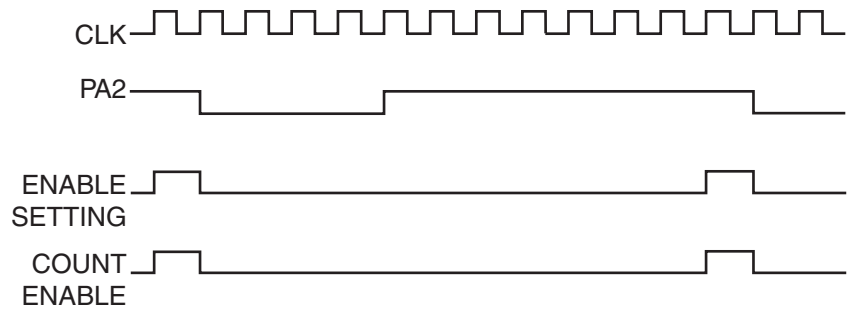


Figure 32 to Figure 35 show examples on output from the Modulator. Figure 32 also shows the timing for the enable setting signal and for the count enable signal to Timer/Counter0.

**Figure 32.** Modulation with  $ONTIM = 3$ ,  $MCONF = 010$ .



Note: 1. Clock frequency: 455 kHz; modulation frequency: 38 kHz; duty-cycle: 33%

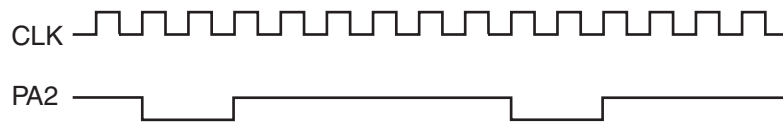
**Figure 33.** Modulation with  $ONTIM = 5$ ,  $MCONF = 001$



Note: Clock frequency: 455 kHz; modulation frequency: 38 kHz; duty-cycle: 50%

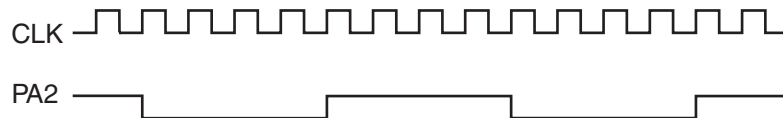


**Figure 34.** Modulation with ONTIM = 1, MCONF = 011



Note: Clock frequency: 3.64 MHz; modulation frequency: 455 kHz; duty-cycle: 25%

**Figure 35.** Modulation with ONTIM = 3, MCONF = 001



Note: Clock frequency: 3.64 MHz; modulation frequency: 455 kHz; duty-cycle: 50%

**Table 17.** Some Common Modulator Configurations

Crystal/Resonator Frequency	Carrier Frequency	% Error in Frequency	Duty-cycle	ONTIM Value	MCONF Value
455 kHz	38 kHz	0.2	25%	2	011
455 kHz	38 kHz	0.2	33%	3	010
455 kHz	38 kHz	0.2	50%	5	001
455 kHz	38 kHz	0.2	67%	3	100
455 kHz	38 kHz	0.2	75%	2	101
1 MHz	38 kHz	1.2	50%	12	001
1.8432 MHz	38 kHz	1.1	25%	11	011
1.8432 MHz	38 kHz	1.1	33%	15	010
1.8432 MHz	38 kHz	1.1	50%	23	001
2 MHz	38 kHz	1.2	25%	12	011
2 MHz	38 kHz	1.2	50%	25	001
2.4576 MHz	38 kHz	1.1	50%	31	001
3.2768 MHz	38 kHz	2.0	25%	21	011
4 MHz	38 kHz	1.2	25%	25	011
455 kHz	455 kHz	0.0	approx. 50%	X	111
1 MHz	455 kHz	9.9	50%	0	001
1.82 MHz	455 kHz	0.0	25%	0	011
1.82 MHz	455 kHz	0.0	50%	1	001
1.8432 MHz	455 kHz	1.3	25%	0	011
1.8432 MHz	455 kHz	1.3	50%	1	001
2 MHz	455 kHz	9.9	25%	0	011

**Table 17.** Some Common Modulator Configurations (Continued)

Crystal/Resonator Frequency	Carrier Frequency	% Error in Frequency	Duty-cycle	ONTIM Value	MCONF Value
2 MHz	455 kHz	9.9	50%	1	001
2.4576 MHz	455 kHz	10.0	33%	1	010
2.4576 MHz	455 kHz	10.0	50%	2	001
3.2768 MHz	455 kHz	10.0	25%	1	011
3.2768 MHz	455 kHz	10.0	50%	3	001
3.64 MHz	455 kHz	0.0	25%	1	011
3.64 MHz	455 kHz	0.0	50%	3	001
4 MHz	455 kHz	9.9	25%	1	011
4 MHz	455 kHz	9.9	50%	3	001

## Register Description

### Modulation Control Register – MODCR

Bit	7	6	5	4	3	2	1	0	
\$02	<b>ONTIM4 ONTIM3 ONTIM2 ONTIM1 ONTIM0 MCONF2 MCONF1 MCONF0</b>								MODCR
Read/Write	R/W	R/W	R/W	R/W	R/W	R/W	R/W	R/W	
Initial Value	0	0	0	0	0	0	0	0	

- Bits 7..3 – ONTIM4..0: Modulation On-time**

This 5-bit value +1 determines the number of clock cycles the output pin PA2 is active (low).

- Bits 2..0 – MCONF2..0: Modulation Configuration Bits 2, 1 and 0**

These three bits determine the relationship between the on- and off-times of the modulator, and thereby the duty-cycle. The various settings are shown in Table 18. The minimum and maximum modulation period is also shown in the table. The minimum modulation period is obtained by setting ONTIM to zero, while the maximum period is obtained by setting ONTIM to 31. The configuration values for some common oscillator and carrier frequencies are listed in Table 17. The relationship between oscillator frequency and carrier frequency is:

$$f_{carrier} = \frac{f_{osc}}{(On-time + Off-time)}$$

If the MCONF register is set to 111, the carrier frequency will be equal to the oscillator frequency.

**Table 18.** MCONF2..0 Effect on Duty-cycle and Modulation Period

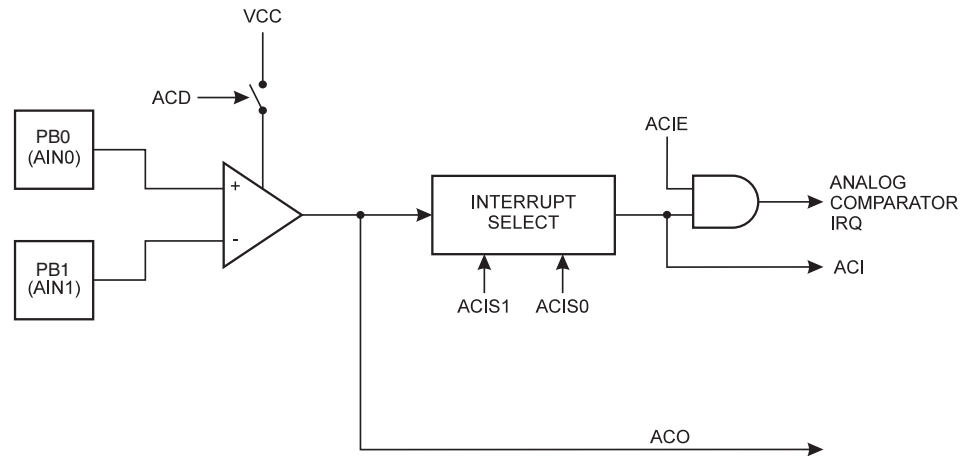
MCONF2..0	On-time	Off-time	Duty-cycle	Min Period	Max Period	Comment
000	X	X	100%	X	X	Unmodulated output
001	ONTIM+1	ONTIM+1	50%	2 CK	64 CK	
010	ONTIM+1	2 x (ONTIM+1)	33%	3 CK	96 CK	
011	ONTIM+1	3 x (ONTIM+1)	25%	4 CK	128 CK	
100	2 x (ONTIM+1)	ONTIM+1	67%	3 CK	96 CK	
101	3 x (ONTIM+1)	ONTIM+1	75%	4 CK	128 CK	
110	Reserved					
111	X	X	Note 1	1 CK	1 CK	High-frequency output

Note: In the high-frequency mode, the output is gated with the clock signal. Thus, the on- and off-times will be dependent on the clock input to the MCU. Also note that when changing from this mode directly to another modulation mode, the output will have a small glitch. Thus, PA2 should be set to stop the modulated output before changing from this mode.

## Analog Comparator

The analog comparator compares the input values on the positive input PB0 (AIN0) and negative input PB1 (AIN1). When the voltage on the positive input PB0 (AIN0) is higher than the voltage on the negative input PB1 (AIN1), the Analog Comparator Output (ACO) is set (one). The comparator can trigger a separate interrupt exclusive to the analog comparator. The user can select interrupt triggering on comparator output rise, fall or toggle. A block diagram of the comparator and its surrounding logic is shown in Figure 36.

**Figure 36.** Analog Comparator Block Diagram



## Register Description

### Analog Comparator Control and Status Register – ACSR

Bit	7	6	5	4	3	2	1	0	
\$08	<b>ACD</b>	–	<b>ACO</b>	<b>ACI</b>	<b>ACIE</b>	–	<b>ACIS1</b>	<b>ACIS0</b>	<b>ACSR</b>
Read/Write	R/W	R	R	R/W	R/W	R	R/W	R/W	
Initial Value	1	0	X	0	0	0	0	0	

- **Bit 7 – ACD: Analog Comparator Disable**

When this bit is set (one), the power to the analog comparator is switched off. This bit can be set at any time to turn off the analog comparator. When changing the ACD bit, the Analog Comparator Interrupt must be disabled by clearing the ACIE bit in ACSR. Otherwise, an interrupt can occur when the bit is changed. To use the analog comparator, the user must clear this bit.

- **Bit 6 – Res: Reserved Bit**

This bit is a reserved bit in the ATtiny28 and will always read as zero.

- **Bit 5 – ACO: Analog Comparator Output**

ACO is directly connected to the comparator output.

- **Bit 4 – ACI: Analog Comparator Interrupt Flag**

This bit is set (one) when a comparator output event triggers the interrupt mode defined by ACI1 and ACI0. The Analog Comparator Interrupt routine is executed if the ACIE bit is set (one) and the I-bit in SREG is set (one). ACI is cleared by hardware when execut-

ing the corresponding interrupt handling vector. Alternatively, ACI is cleared by writing a logical “1” to the flag.

- **Bit 3 – ACIE: Analog Comparator Interrupt Enable**

When the ACIE bit is set (one) and the I-bit in the Status Register is set (one), the analog comparator interrupt is activated. When cleared (zero), the interrupt is disabled.

- **Bit 2 – RES: Reserved Bit**

This bit is a reserved bit in the ATTiny28 and will always read as zero.

- **Bits 1, 0 - ACIS1, ACIS0: Analog Comparator Interrupt Mode Select**

These bits determine which comparator events trigger the Analog Comparator Interrupt. The different settings are shown in Table 19.

**Table 19.** ACIS1/ACIS0 Settings

ACIS1	ACIS0	Interrupt Mode
0	0	Comparator Interrupt on Output Toggle
0	1	Reserved
1	0	Comparator Interrupt on Falling Output Edge
1	1	Comparator Interrupt on Rising Output Edge

Note: When changing the ACIS1/ACIS0 bits, the Analog Comparator Interrupt must be disabled by clearing its Interrupt Enable bit in the ACSR register. Otherwise, an interrupt can occur when the bits are changed.

**Caution:** Using the SBI or CBI instruction on bits other than ACI in this register will write a one back into ACI if it is read as set, thus clearing the flag.

## Memory Programming

### Program Memory Lock Bits

The ATtiny28 MCU provides two Lock bits that can be left unprogrammed (“1”) or can be programmed (“0”) to obtain the additional features listed in Table 20. The Lock bits can only be erased with the Chip Erase command.

**Table 20.** Lock Bit Protection Modes

Memory Lock Bits			Protection Type
Mode	LB1	LB2	
1	1	1	No memory lock features enabled.
2	0	1	Further programming of the Flash is disabled. <sup>(1)</sup>
3	0	0	Same as mode 2, and verify is also disabled.

Note: 1. Further programming of the Fuse bits is also disabled. Program the Fuse bits before programming the Lock bits.

### Fuse Bits

The ATtiny28 has five Fuse bits, INTCAP and CKSEL3..0.

- When the INTCAP Fuse is programmed (“0”), internal load capacitors are connected between XTAL1/XTAL2 and GND, similar to C1 and C2 in Figure 5. See “Crystal Oscillator” on page 7. Default value is unprogrammed (“1”).
- CKSEL3..0 Fuses: See Table 1, “Device Clocking Option Select,” on page 7 and Table 5, “ATtiny28 Clock Options and Start-up Time,” on page 16, for which combination of CKSEL3..0 to use. Default value is “0010”, internal RC oscillator with long start-up time.

The status of the Fuse bits is not affected by Chip Erase.

### Signature Bytes

All Atmel microcontrollers have a 3-byte signature code that identifies the device. The three bytes reside in a separate address space.

For the ATtiny28, they are:

1. \$000: \$1E (indicates manufactured by Atmel)
2. \$001: \$91 (indicates 2 KB Flash memory)
3. \$002: \$07 (indicates ATtiny28 device when signature byte \$001 is \$91)

### Calibration Byte

The ATtiny28 has one byte calibration value for the internal RC oscillator. This byte resides in the high byte of address \$000 in the signature address space. During memory programming, the external programmer must read this location, and program it into a selected location in the the normal Flash program memory. At start-up, the user software must read this Flash location and write the value to the OSCCAL register.

## Programming the Flash

Atmel's ATtiny28 offers 2K bytes of Flash program memory.

The ATtiny28 is shipped with the on-chip Flash program memory array in the erased state (i.e., contents = \$FF) and ready to be programmed. This device supports a high-voltage (12V) parallel programming mode. Only minor currents (<1mA) are drawn from the +12V pin during programming.

The program memory array in the ATtiny28 is programmed byte-by-byte. During programming, the supply voltage must be in accordance with Table 21.

**Table 21.** Supply Voltage during Programming

Part	Serial Programming	Parallel Programming
ATtiny28	Not applicable	4.5 - 5.5V

## Parallel Programming

This section describes how to parallel program and verify Flash program memory, Lock bits and Fuse bits in the ATtiny28.

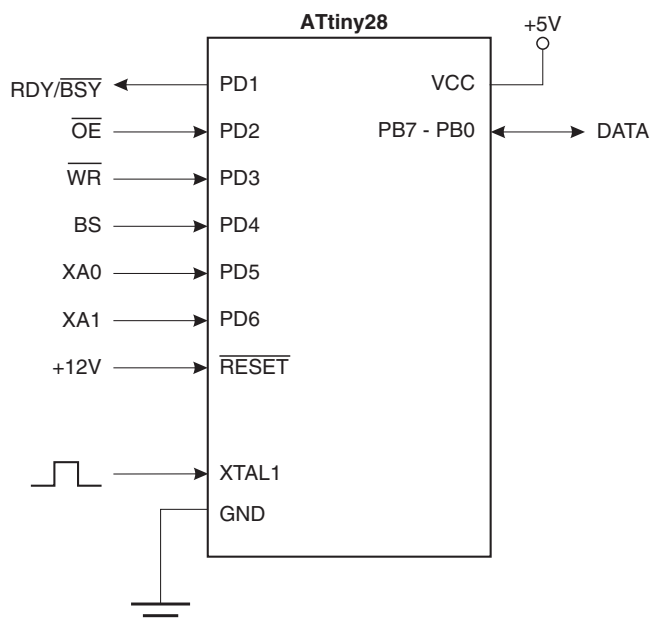
### Signal Names

In this section, some pins of the ATtiny28 are referenced by signal names describing their function during parallel programming. See Figure 37 and Table 22. Pins not described in Table 22 are referenced by pin name.

The XA1/XA0 pins determine the action executed when the XTAL1 pin is given a positive pulse. The coding is shown in Table 23.

When pulsing  $\overline{WR}$  or  $\overline{OE}$ , the command loaded determines the action executed. The command is a byte where the different bits are assigned functions, as shown in Table 24.

**Figure 37.** Parallel Programming



**Table 22.** Pin Name Mapping

Signal Name in Programming Mode	Pin Name	I/O	Function
RDY/ $\overline{\text{BSY}}$	PD1	O	"0": Device is busy programming, "1": Device is ready for new command
$\overline{\text{OE}}$	PD2	I	Output Enable (active low)
$\overline{\text{WR}}$	PD3	I	Write Pulse (active low)
BS	PD4	I	Byte Select ("0" selects low byte, "1" selects high byte)
XA0	PD5	I	XTAL1 Action Bit 0
XA1	PD6	I	XTAL1 Action Bit 1
DATA	PB7 - PB0	I/O	Bi-directional Data Bus (output when $\overline{\text{OE}}$ is low)

**Table 23.** XA1 and XA0 Coding

XA1	XA0	Action when XTAL1 is Pulsed
0	0	Load Flash/Signature byte Address (High or low address byte for Flash determined by BS)
0	1	Load Data (High or low data byte for Flash determined by BS)
1	0	Load Command
1	1	No Action, Idle

**Table 24.** Command Byte Coding

Command Byte	Command Executed
1000 0000	Chip Erase
0100 0000	Write Fuse Bits
0010 0000	Write Lock Bits
0001 0000	Write Flash
0000 1000	Read Signature Bytes and Calibration Byte
0000 0100	Read Fuse and Lock Bits
0000 0010	Read Flash

**Enter Programming Mode**

The following algorithm puts the device in parallel programming mode:

1. Apply 4.5 - 5.5V between VCC and GND.
2. Set  $\overline{\text{RESET}}$  and BS pins to "0" and wait at least 100 ns.
3. Apply 11.5 - 12.5V to  $\overline{\text{RESET}}$ . Any activity on BS within 100 ns after +12V has been applied to  $\overline{\text{RESET}}$  will cause the device to fail entering programming mode.



## Chip Erase

The Chip Erase command will erase the Flash memory and the Lock bits. The Lock bits are not reset until the Flash has been completely erased. The Fuse bits are not changed. Chip Erase must be performed before the Flash is reprogrammed.

Load Command "Chip Erase"

1. Set XA1, XA0 to "10". This enables command loading.
2. Set BS to "0".
3. Set DATA to "1000 0000". This is the command for Chip Erase.
4. Give XTAL1 a positive pulse. This loads the command.
5. Give  $\overline{WR}$  a negative pulse. This starts the Chip Erase. RDY/ $\overline{BSY}$  goes low.
6. Wait until RDY/ $\overline{BSY}$  goes high before loading a new command.

## Programming the Flash

A: Load Command "Write Flash"

1. Set XA1, XA0 to "10". This enables command loading.
2. Set BS to "0".
3. Set DATA to "0001 0000". This is the command for Write Flash.
4. Give XTAL1 a positive pulse. This loads the command.

B: Load Address High Byte

1. Set XA1, XA0 to "00". This enables address loading.
2. Set BS to "1". This selects high byte.
3. Set DATA = Address high byte (\$00 - \$03).
4. Give XTAL1 a positive pulse. This loads the address high byte.

C: Load Address Low Byte

1. Set XA1, XA0 to "00". This enables address loading.
2. Set BS to "0". This selects low byte.
3. Set DATA = Address low byte (\$00 - \$FF).
4. Give XTAL1 a positive pulse. This loads the address low byte.

D: Load Data Low Byte

1. Set XA1, XA0 to "01". This enables data loading.
2. Set DATA = Data low byte (\$00 - \$FF).
3. Give XTAL1 a positive pulse. This loads the data low byte.

E: Write Data Low Byte

1. Set BS to "0". This selects low data.
2. Give  $\overline{WR}$  a negative pulse. This starts programming of the data byte. RDY/ $\overline{BSY}$  goes low.
3. Wait until RDY/ $\overline{BSY}$  goes high to program the next byte.

(See Figure 38 for signal waveforms.)

F: Load Data High Byte

1. Set XA1, XA0 to "01". This enables data loading.
2. Set DATA = Data high byte (\$00 - \$FF).
3. Give XTAL1 a positive pulse. This loads the data high byte.

G: Write Data High Byte

1. Set BS to “1”. This selects high data.
2. Give  $\overline{WR}$  a negative pulse. This starts programming of the data byte.  $RDY/\overline{BSY}$  goes low.
3. Wait until  $RDY/\overline{BSY}$  goes high to program the next byte.

(See Figure 39 for signal waveforms.)

The loaded command and address are retained in the device during programming. For efficient programming, the following should be considered:

- The command needs to be loaded only once when writing or reading multiple memory locations.
- Address high byte only needs to be loaded before programming a new 256-word page in the Flash.
- Skip writing the data value \$FF, that is, the contents of the entire Flash after a Chip Erase.

These considerations also apply to Flash and signature bytes reading.

### Reading the Flash

The algorithm for reading the Flash memory is as follows (refer to “Programming the Flash” for details on command and address loading):

A: Load Command “0000 0010”.

B: Load Address High Byte (\$00 - \$03).

C: Load Address Low Byte (\$00 - \$FF).

1. Set  $\overline{OE}$  to “0”, and BS to “0”. The Flash word low byte can now be read at DATA.
2. Set BS to “1”. The Flash word high byte can now be read from DATA.
3. Set  $\overline{OE}$  to “1”.

### Programming the Fuse Bits

The algorithm for programming the Fuse bits is as follows (refer to “Programming the Flash” for details on command and data loading):

A: Load Command “0100 0000”.

D: Load Data Low Byte. Bit n = “0” programs and bit n = “1” erases the Fuse bit.

Bit 4 = INTCAP Fuse

Bit 3 = CKSEL3 Fuse

Bit 2 = CKSEL2 Fuse

Bit 1 = CKSEL1 Fuse

Bit 0 = CKSEL0 Fuse

Bits 7 - 5 = “1”. These bits are reserved and should be left unprogrammed (“1”).

E: Write Data Low Byte.

### Programming the Lock Bits

The algorithm for programming the Lock bits is as follows (refer to “Programming the Flash” for details on command and data loading):

A: Load Command “0010 0000”.

D: Load Data Low Byte. Bit n = “0” programs the Lock bit.

Bit 2 = Lock Bit2

Bit 1 = Lock Bit1

Bits 7 - 3,0 = “1”. These bits are reserved and should be left unprogrammed (“1”).

E: Write Data Low Byte.

The Lock bits can only be cleared by executing Chip Erase.

## Reading the Fuse and Lock Bits

The algorithm for reading the Fuse and Lock bits is as follows (refer to “Programming the Flash” for details on command loading):

A: Load Command “0000 0100”.

1. Set  $\overline{OE}$  to “0”, and BS to “0”. The status of the Fuse bits can now be read at DATA (“0” means programmed).

Bit 4 = INTCAP Fuse  
 Bit 3 = CKSEL3 Fuse  
 Bit 2 = CKSEL2 Fuse  
 Bit 1 = CKSEL1 Fuse  
 Bit 0 = CKSEL0 Fuse

2. Set BS to “1”. The status of the Lock bits can now be read at DATA (“0” means programmed).

Bit 2: Lock Bit2  
 Bit 1: Lock Bit1

3. Set  $\overline{OE}$  to “1”.

## Reading the Signature Bytes and Calibration Byte

The algorithm for reading the signature bytes and the calibration byte is as follows (refer to “Programming the Flash” for details on command and address loading):

A: Load Command “0000 1000”.

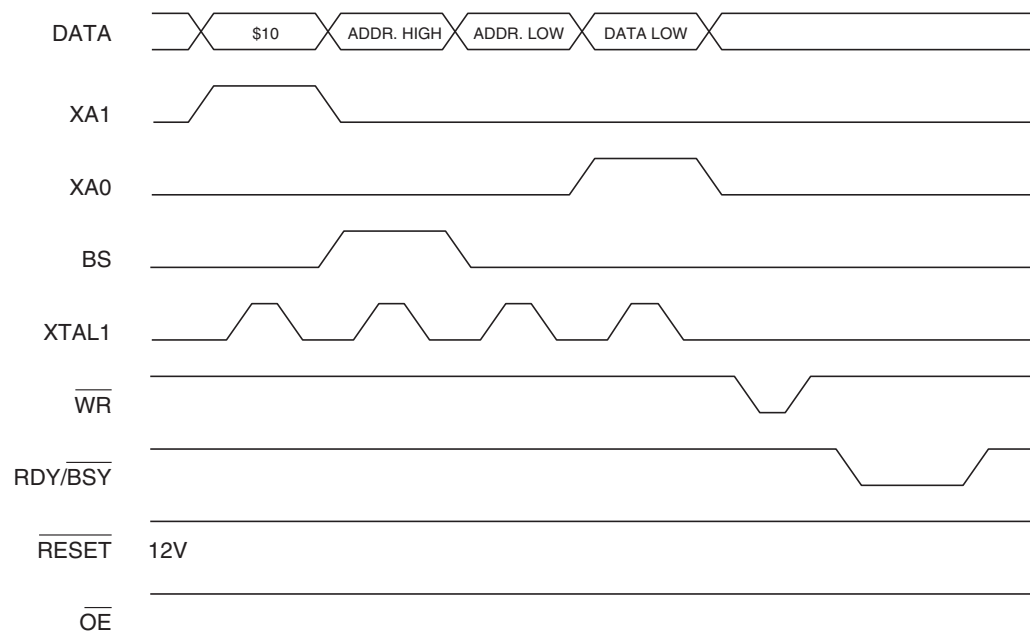
C: Load Address Low Byte (\$00 - \$02).

1. Set  $\overline{OE}$  to “0”, and BS to “0”. The selected signature byte can now be read at DATA.

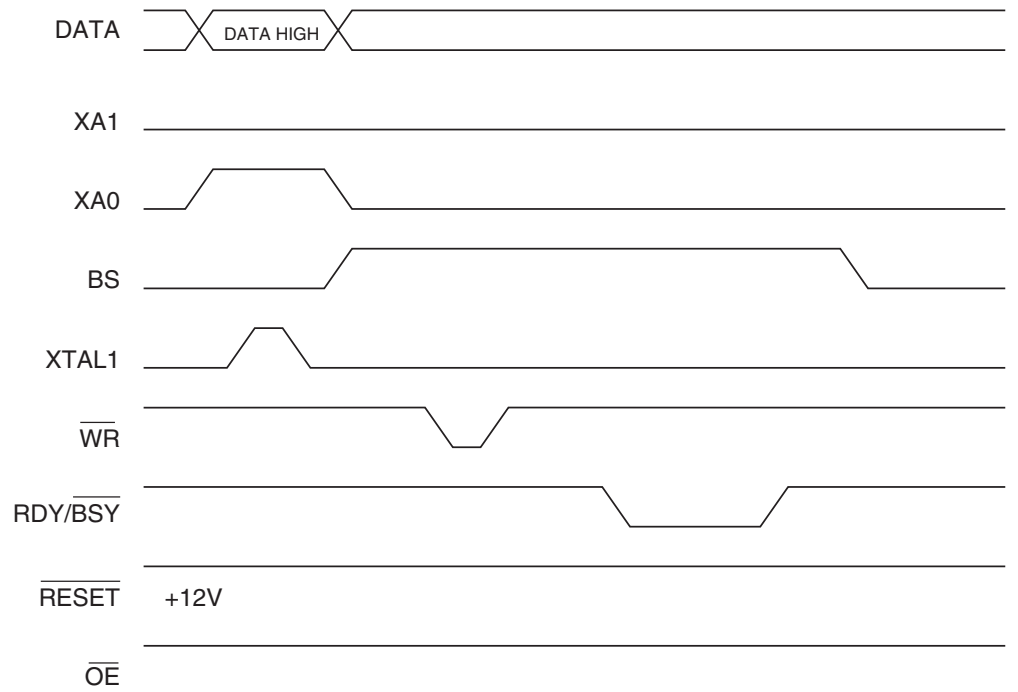
C: Load Address Low Byte (\$00).

1. Set  $\overline{OE}$  to “0”, and BS to “1”. The calibration byte can now be read at DATA.
2. Set  $\overline{OE}$  to “1”.

**Figure 38.** Programming the Flash Waveforms

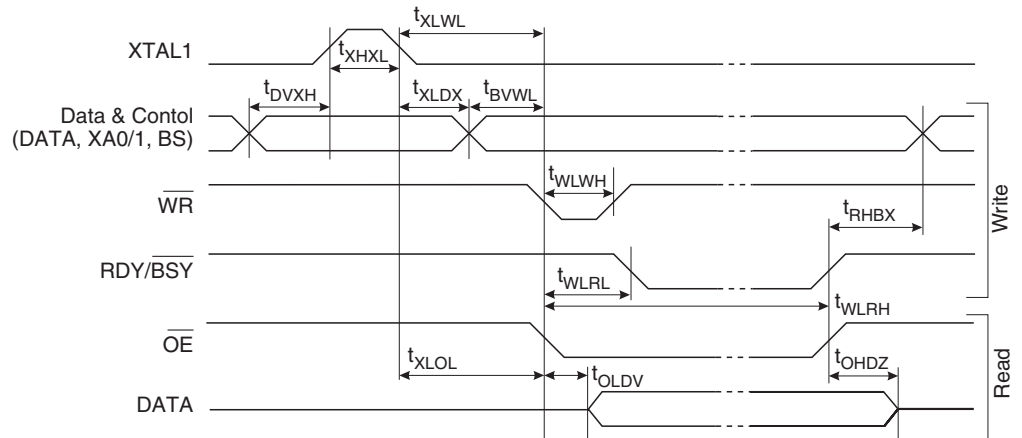


**Figure 39.** Programming the Flash Waveforms (Continued)



## Parallel Programming Characteristics

Figure 40. Parallel Programming Timing



$T_A = 25^\circ\text{C} \pm 10\%$ ,  $V_{CC} = 5\text{V} \pm 10\%$

Symbol	Parameter	Min	Typ	Max	Unit
$V_{PP}$	Programming Enable Voltage	11.5		12.5	V
$I_{PP}$	Programming Enable Current			250.0	$\mu\text{A}$
$t_{DVXH}$	Data & Control Valid before XTAL1 High	67.0			ns
$t_{XHL}$	XTAL1 Pulse Width High	67.0			ns
$t_{XLDX}$	Data & Control Hold after XTAL1 Low	67.0			ns
$t_{XLWL}$	XTAL1 Low to $\overline{WR}$ Low	67.0			ns
$t_{BVWL}$	BS Valid to $\overline{WR}$ Low	67.0			ns
$t_{RHBX}$	BS Hold after RDY/BSY High	67.0			ns
$t_{WLVH}$	$\overline{WR}$ Pulse Width Low	67.0			ns
$t_{WLRH}$	$\overline{WR}$ Low to RDY/BSY High	0.0		2.5	$\mu\text{s}$
$t_{WLRH}$	$\overline{WR}$ Low to RDY/BSY High	0.5	0.7	0.9	ms
$t_{XLOL}$	XTAL1 Low to $\overline{OE}$ Low	67.0			ns
$t_{OLDV}$	$\overline{OE}$ Low to DATA Valid		20.0		ns
$t_{OHDZ}$	$\overline{OE}$ High to DATA Tri-stated			20.0	ns



## Electrical Characteristics

### Absolute Maximum Ratings

Operating Temperature.....	-40°C to +85/105°C
Storage Temperature.....	-65°C to +150°C
Voltage on Any Pin except $\overline{\text{RESET}}$ with Respect to Ground.....	-1.0V to $V_{CC} + 0.5V$
Maximum Operating Voltage.....	6.0V
Voltage on $\overline{\text{RESET}}$ with Respect to Ground....	-1.0V to +13.0V
DC Current per I/O Pin, except PA2.....	40.0 mA
DC Current PA2.....	60.0 mA
DC Current VCC and GND Pin.....	300.0 mA

\*NOTICE: Stresses beyond those ratings listed under “Absolute Maximum Ratings” may cause permanent damage to the device. This is a stress rating only and functional operation of the device at these or other conditions beyond those indicated in the operational sections of this specification is not implied. Exposure to absolute maximum rating conditions for extended periods may affect device reliability.

### DC Characteristics

$T_A = -40^\circ\text{C}$  to  $85^\circ\text{C}$ ,  $V_{CC} = 1.8V$  to  $5.5V$  (unless otherwise noted)

Symbol	Parameter	Condition	Min	Typ	Max	Units
$V_{IL}$	Input Low Voltage	(Except XTAL)	-0.5		$0.3 V_{CC}^{(1)}$	V
$V_{IL1}$	Input Low Voltage	XTAL	-0.5		$0.1 V_{CC}^{(1)}$	V
$V_{IH}$	Input High Voltage	(Except XTAL, $\overline{\text{RESET}}$ )	$0.6 V_{CC}^{(2)}$		$V_{CC} + 0.5$	V
$V_{IH1}$	Input High Voltage	XTAL	$0.7 V_{CC}^{(2)}$		$V_{CC} + 0.5$	V
$V_{IH2}$	Input High Voltage	RESET	$0.85 V_{CC}^{(2)}$		$V_{CC} + 0.5$	V
$V_{OL}$	Output Low Voltage <sup>(3)</sup> Ports A, D	$I_{OL} = 20 \text{ mA}$ , $V_{CC} = 5V$			0.6	V
		$I_{OL} = 10 \text{ mA}$ , $V_{CC} = 3V$			0.5	V
$V_{OL}$	Output Low Voltage <sup>(3)</sup> Port A2	$I_{OL} = 25 \text{ mA}$ , $V_{CC} = 2.0V$			1.0	V V
$V_{OH}$	Output High Voltage <sup>(4)</sup> Ports A, D	$I_{OH} = -3 \text{ mA}$ , $V_{CC} = 5V$	4.3			V
		$I_{OH} = -1.5 \text{ mA}$ , $V_{CC} = 3V$	2.3			V
$I_{IL}$	Input Leakage Current I/O Pin	$V_{CC} = 5.5V$ , pin low (absolute value)			8.0	$\mu\text{A}$
$I_{IL}$	Input Leakage Current I/O Pin	$V_{CC} = 5.5V$ , pin high (absolute value)			8.0	$\mu\text{A}$
$R_{I/O}$	I/O Pin Pull-up		35.0		122.0	$k\Omega$
$I_{CC}$	Power Supply Current	Active Mode, $V_{CC} = 3V$ , 4 MHz			3.0	mA
		Idle Mode $V_{CC} = 3V$ , 4 MHz		1.0	1.2	mA
		Power-down <sup>(5)(6)</sup> , $V_{CC} = 3V$ WDT enabled		9.0	15.0	$\mu\text{A}$
		Power-down <sup>(5)(6)</sup> , $V_{CC} = 3V$ WDT disabled		<1.0	2.0	$\mu\text{A}$

## DC Characteristics (Continued)

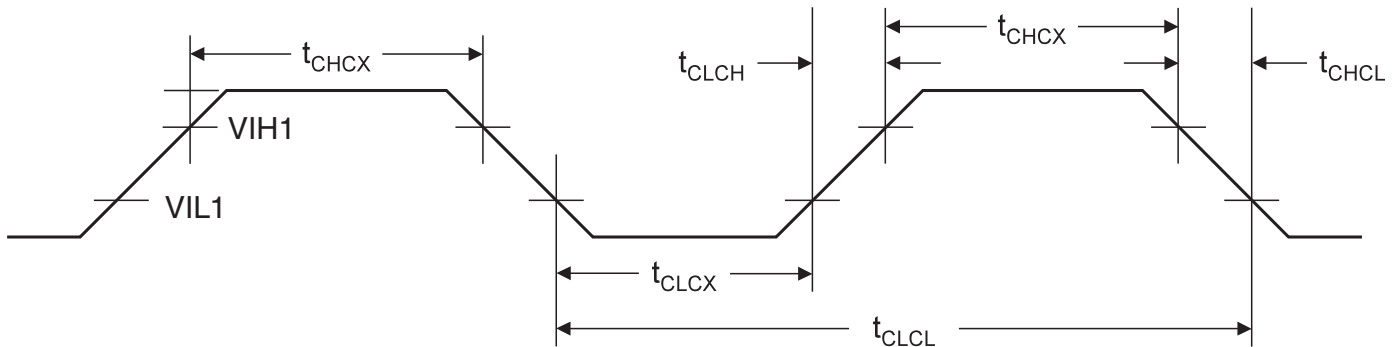
$T_A = -40^{\circ}\text{C}$  to  $85^{\circ}\text{C}$ ,  $V_{CC} = 1.8\text{V}$  to  $5.5\text{V}$  (unless otherwise noted)

Symbol	Parameter	Condition	Min	Typ	Max	Units
$V_{ACIO}$	Analog Comparator Input Offset Voltage	$V_{CC} = 5\text{V}$ $V_{IN} = V_{CC}/2$			40.0	mV
$I_{ACLK}$	Analog Comparator Input Leakage Current	$V_{CC} = 5\text{V}$ $V_{IN} = V_{CC}/2$	-50.0		50.0	nA
$T_{ACPD}$	Analog Comparator Propagation Delay	$V_{CC} = 2.7\text{V}$ $V_{CC} = 4.0\text{V}$		750.0 500.0		ns

- Notes:
1. "Max" means the highest value where the pin is guaranteed to be read as low.
  2. "Min" means the lowest value where the pin is guaranteed to be read as high.
  3. Although each I/O port can sink more than the test conditions (20 mA at  $V_{CC} = 5\text{V}$ , 10 mA at  $V_{CC} = 3\text{V}$ ) under steady-state conditions (non-transient), the following must be observed:
    - 1] The sum of all  $I_{OL}$  for all ports, should not exceed 300 mA.
    - 2] The sum of all  $I_{OL}$  for port D0 - D7 and XTAL2 should not exceed 100 mA.
 If  $I_{OL}$  exceeds the test condition,  $V_{OL}$  may exceed the related specification.  
 Pins are not guaranteed to sink current greater than the listed test conditions.
  4. Although each I/O port can source more than the test conditions (3 mA at  $V_{CC} = 5\text{V}$ , 1.5 mA at  $V_{CC} = 3\text{V}$ ) under steady-state conditions (non-transient), the following must be observed:
    - 1] The sum of all  $I_{OH}$  for all ports, should not exceed 300 mA.
    - 2] The sum of all  $I_{OH}$  for port D0 - D7 and XTAL2 should not exceed 100 mA.
 If  $I_{OH}$  exceeds the test condition,  $V_{OH}$  may exceed the related specification.  
 Pins are not guaranteed to source current greater than the listed test conditions.
  5. Minimum  $V_{CC}$  for power-down is 1.5V.
  6. When entering Power-down, PORTA2 bit in PORTA register should be set.

## External Clock Drive Waveforms

Figure 41. External Clock



## External Clock Drive

Symbol	Parameter	$V_{CC} = 1.8V \text{ to } 2.7V$		$V_{CC} = 2.7V \text{ to } 4.0V$		$V_{CC} = 4.0V \text{ to } 5.5V$		Units
		Min	Max	Min	Max	Min	Max	
$1/t_{CLCL}$	Oscillator Frequency	0.0	1.2	0.0	4.0	0.0	4.0	MHz
$t_{CLCL}$	Clock Period	833.0		250.0		250.0		ns
$t_{CHCX}$	High Time	333.0		100.0		100.0		ns
$t_{CLCX}$	Low Time	333.0		100.0		100.0		ns
$t_{CLCH}$	Rise Time		1.6		1.6		0.5	$\mu s$
$t_{CHCL}$	Fall Time		1.6		1.6		0.5	$\mu s$

Table 25. External RC Oscillator, Typical Frequencies

R [k $\Omega$ ]	C [pF]	f
100.0	70.0	100.0 kHz
31.5	20.0	1.0 MHz
6.5	20.0	4.0 MHz

Note: R should be in the range 3 - 100 k $\Omega$ , and C should be at least 20 pF.



## Typical Characteristics

The following charts show typical behavior. These figures are not tested during manufacturing. All current consumption measurements are performed with all I/O pins configured as inputs and with internal pull-ups enabled. A sine wave generator with rail-to-rail output is used as clock source.

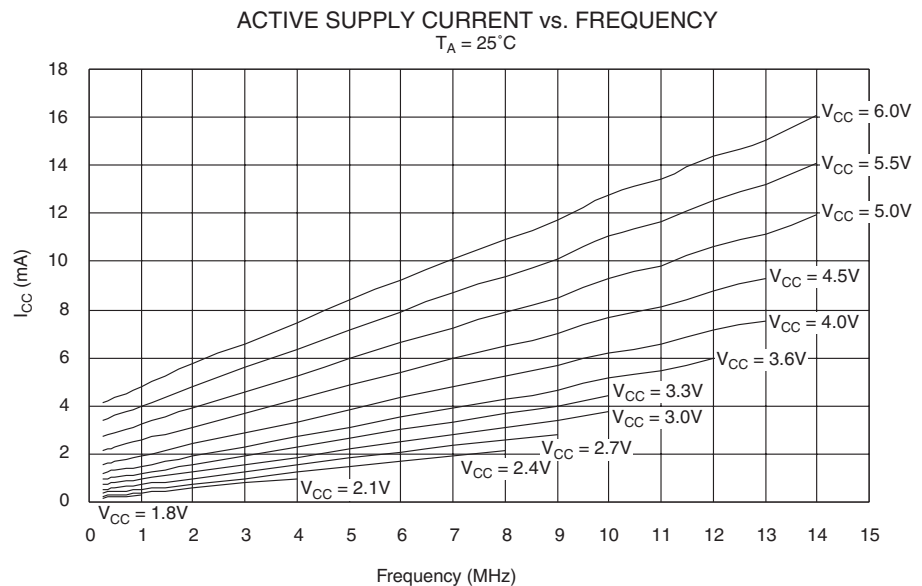
The power consumption in Power-down mode is independent of clock selection.

The current consumption is a function of several factors, such as: operating voltage, operating frequency, loading of I/O pins, switching rate of I/O pins, code executed and ambient temperature. The dominating factors are operating voltage and frequency. The current drawn from capacitive loaded pins may be estimated (for one pin) as  $C_L \cdot V_{CC} \cdot f$ , where  $C_L$  = Load Capacitance,  $V_{CC}$  = Operating Voltage and  $f$  = Average Switching Frequency of I/O pin.

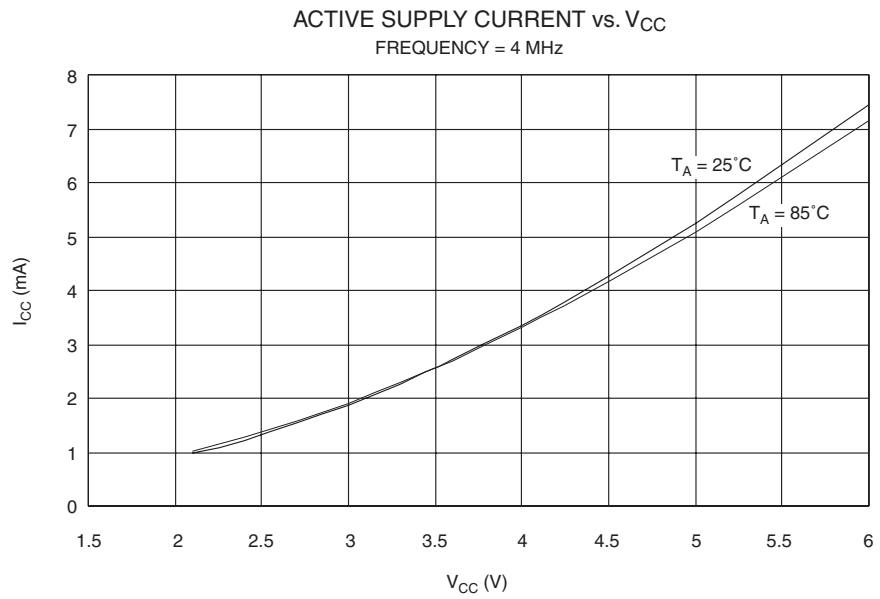
The parts are characterized at frequencies and voltages higher than test limits. Parts are not guaranteed to function properly at frequencies and voltages higher than the ordering code indicates.

The difference between current consumption in Power-down mode with Watchdog Timer enabled and Power-down mode with Watchdog Timer disabled represents the differential current drawn by the Watchdog Timer.

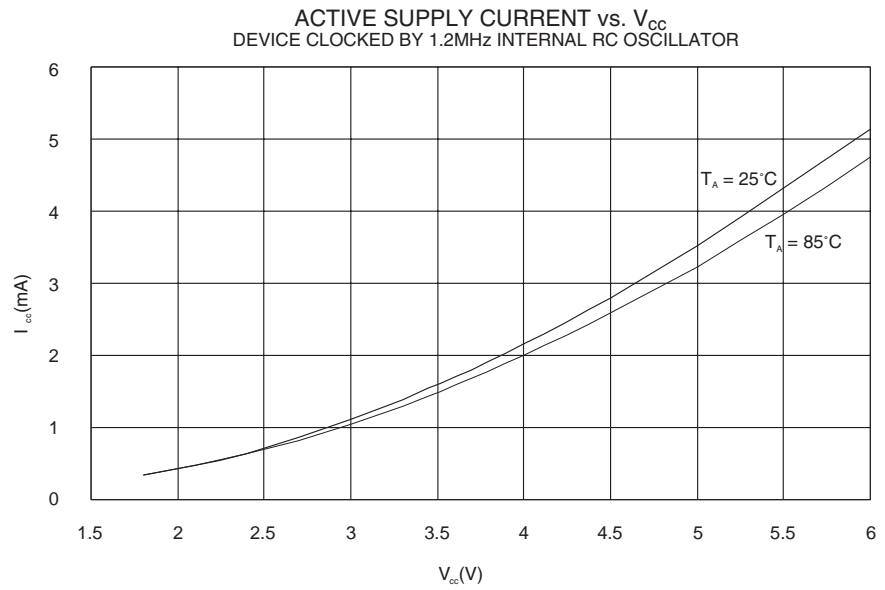
**Figure 42.** Active Supply Current vs. Frequency



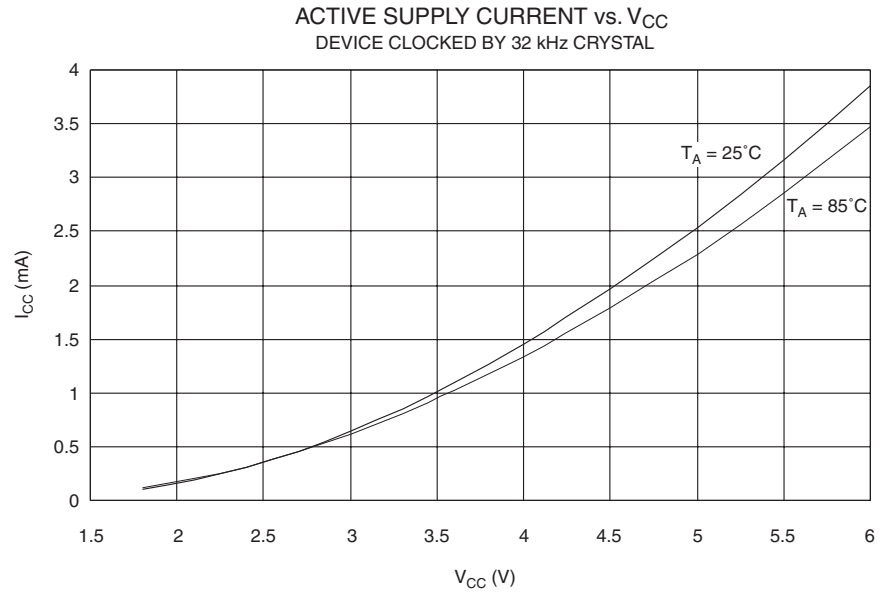
**Figure 43.** Active Supply Current vs.  $V_{CC}$



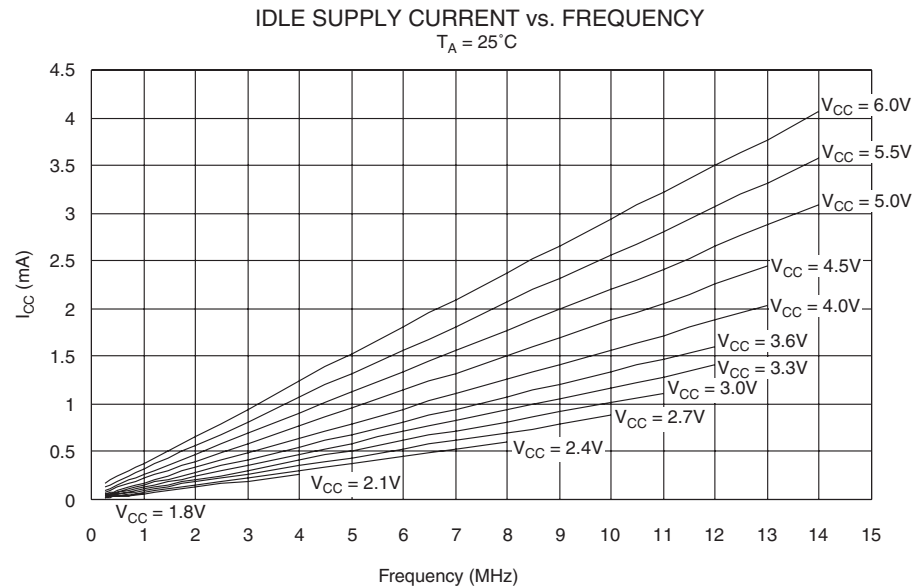
**Figure 44.** Active Supply Current vs.  $V_{CC}$ , Device Clocked by Internal Oscillator



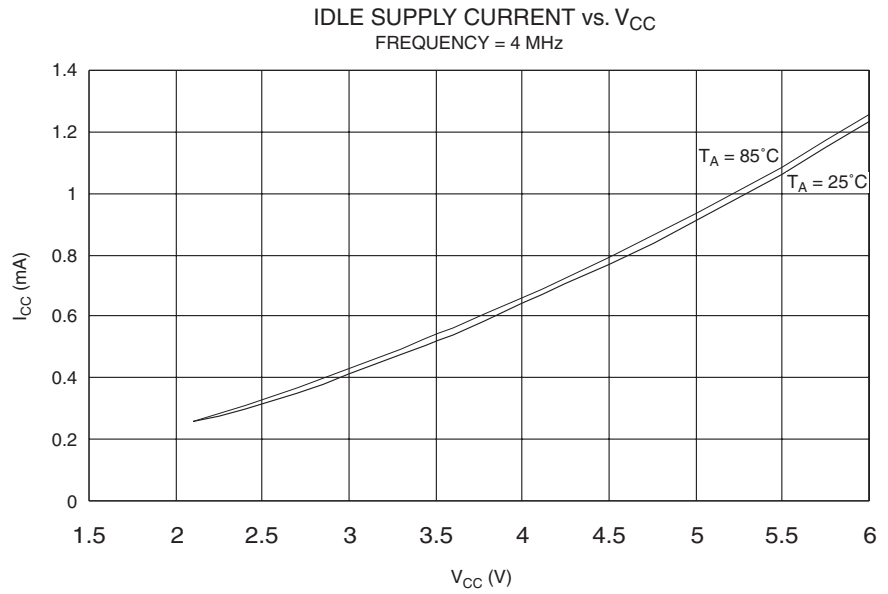
**Figure 45.** Active Supply Current vs.  $V_{CC}$ , Device Clocked by External 32 kHz Crystal



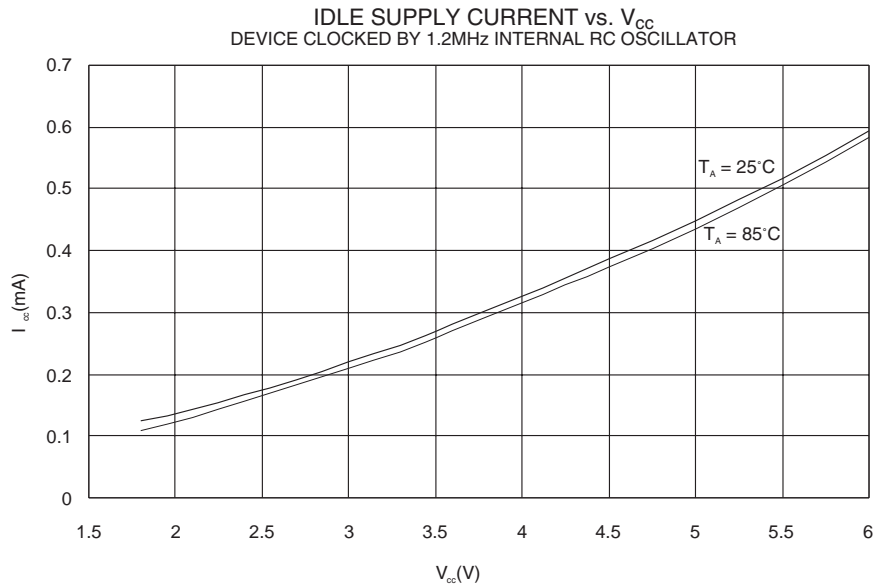
**Figure 46.** Idle Supply Current vs. Frequency



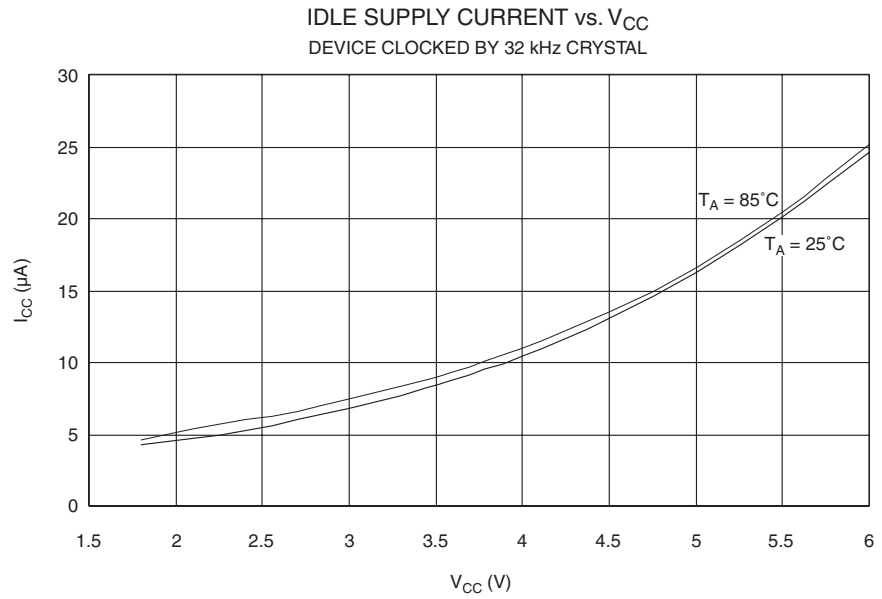
**Figure 47.** Idle Supply Current vs.  $V_{CC}$



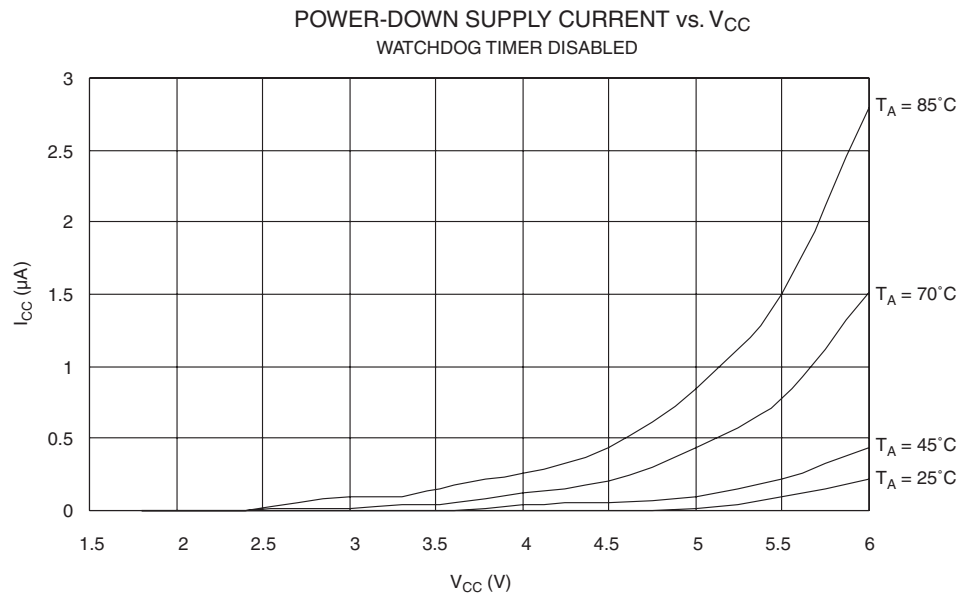
**Figure 48.** Idle Supply Current vs.  $V_{CC}$ , Device Clocked by Internal Oscillator



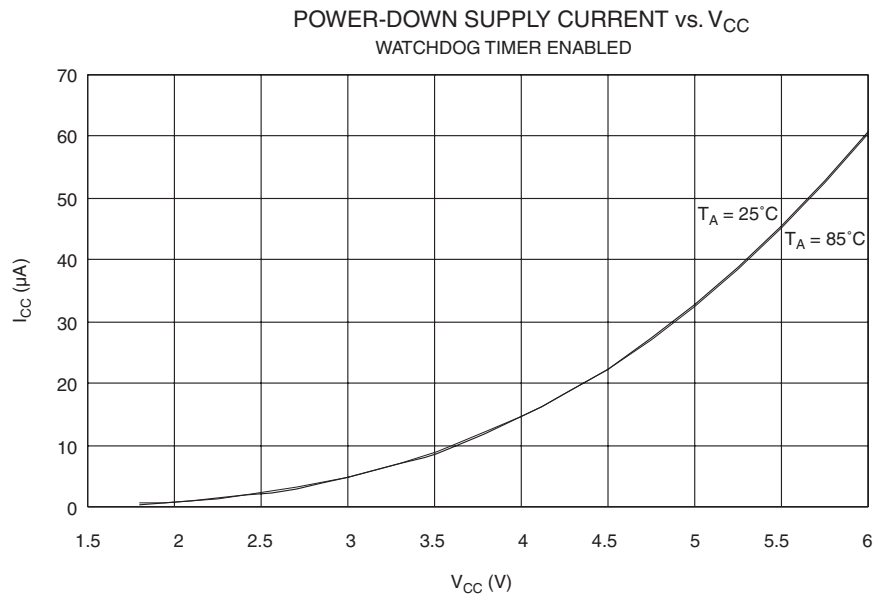
**Figure 49.** Idle Supply Current vs.  $V_{CC}$ , Device Clocked by External 32 kHz Crystal



**Figure 50.** Power-down Supply Current vs.  $V_{CC}$

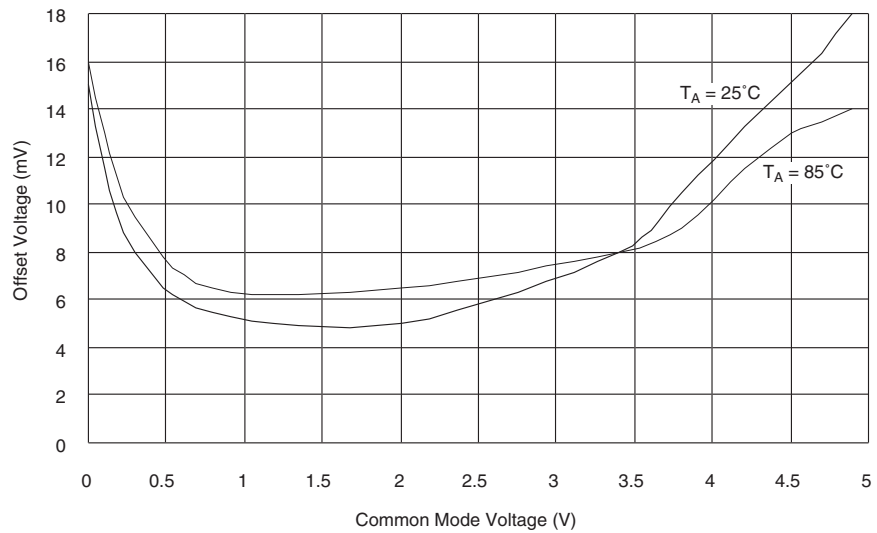


**Figure 51.** Power-down Supply Current vs.  $V_{CC}$

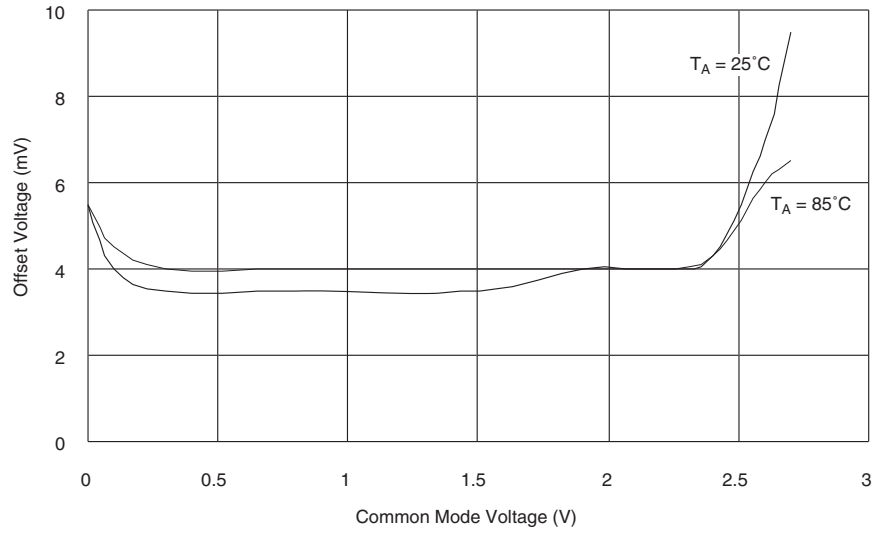


Analog comparator offset voltage is measured as absolute offset.

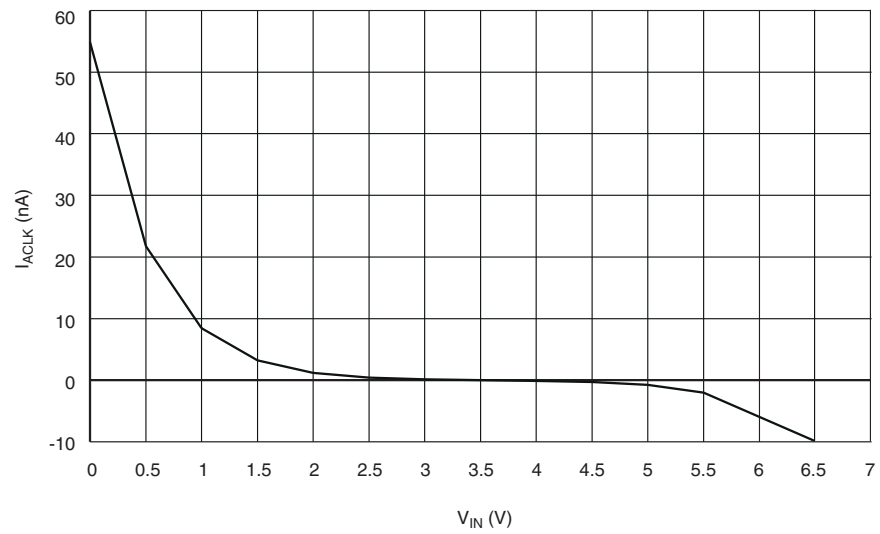
**Figure 52.** Analog Comparator Offset Voltage vs. Common Mode Voltage ( $V_{CC} = 5V$ )



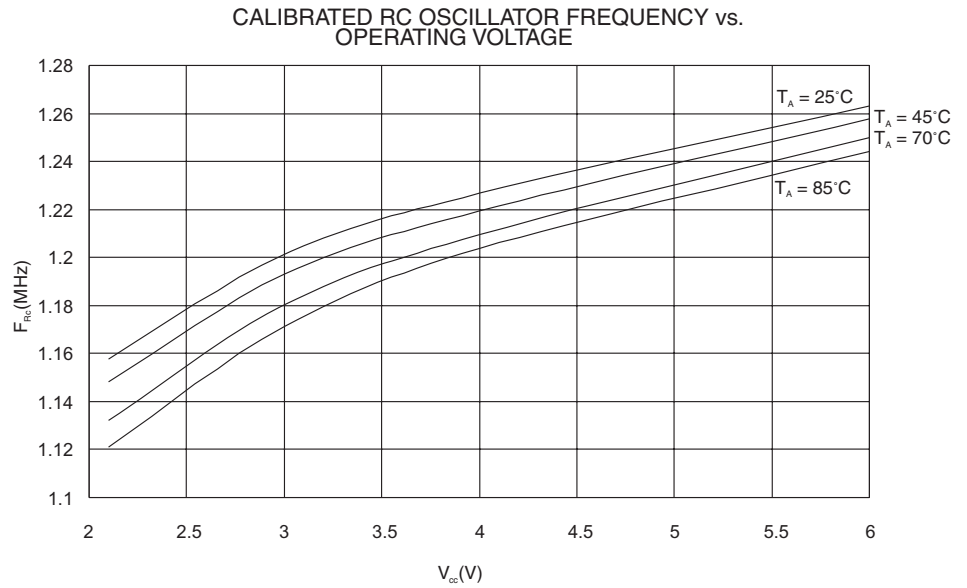
**Figure 53.** Analog Comparator Offset Voltage vs. Common Mode Voltage ( $V_{CC} = 2.7V$ )



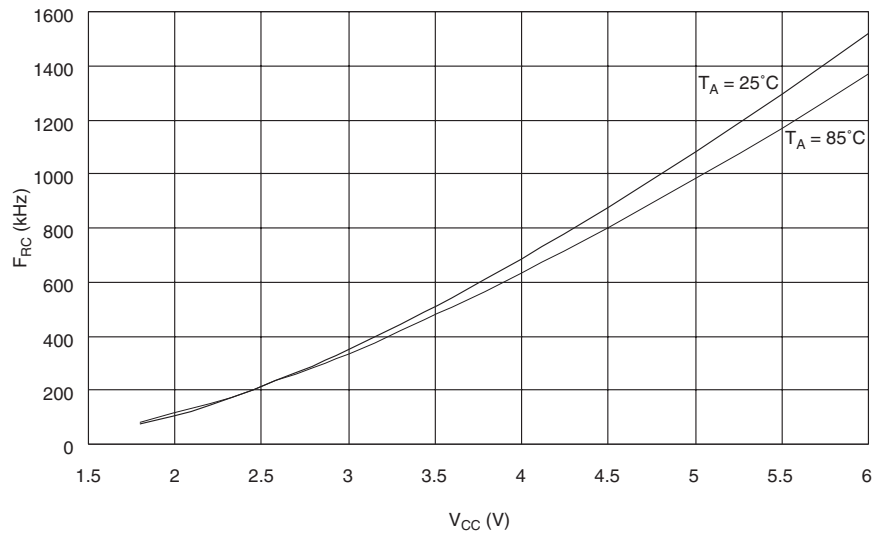
**Figure 54.** Analog Comparator Input Leakage Current ( $V_{CC} = 6V$ ;  $T_A = 25^\circ C$ )



**Figure 55.** Calibrated Internal RC Oscillator Frequency vs.  $V_{CC}$



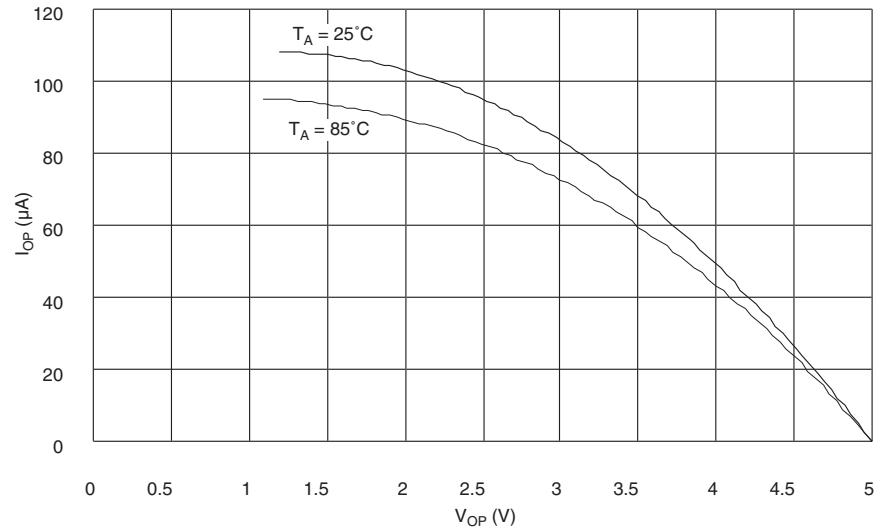
**Figure 56.** Watchdog Oscillator Frequency vs.  $V_{CC}$



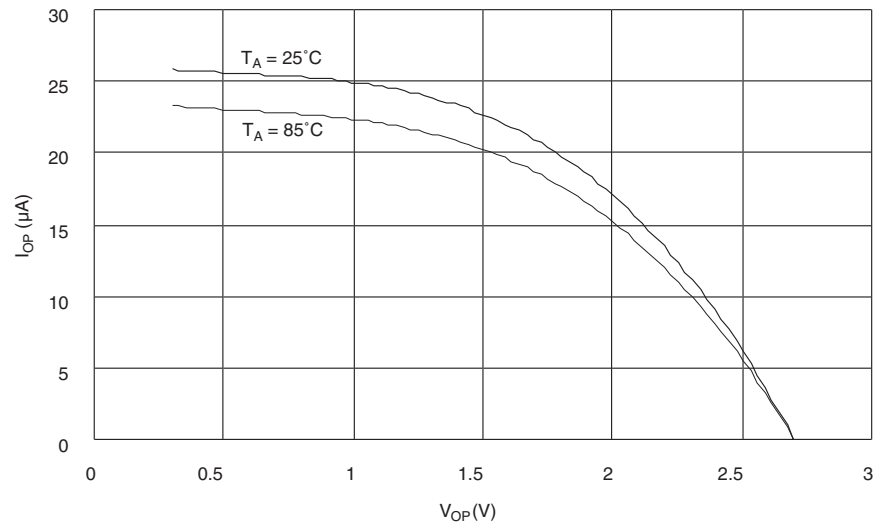


Sink and source capabilities of I/O ports are measured on one pin at a time.

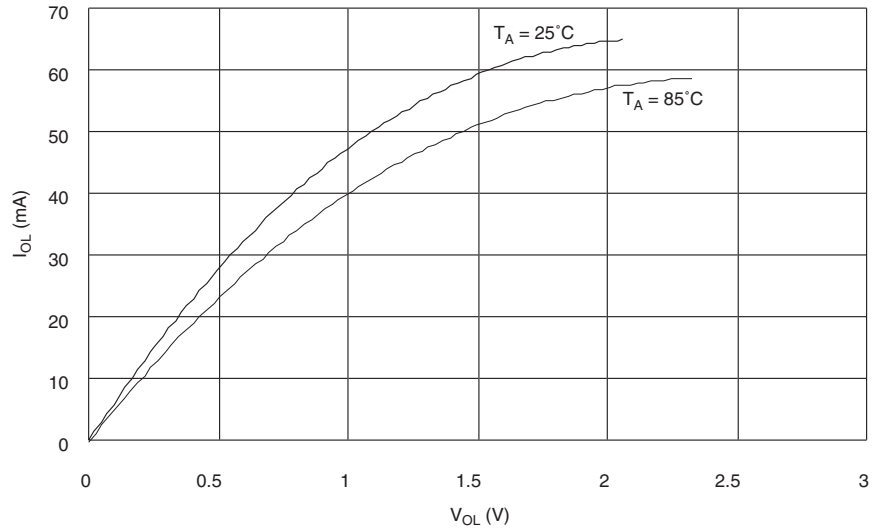
**Figure 57.** Pull-up Resistor Current vs. Input Voltage ( $V_{CC} = 5V$ )



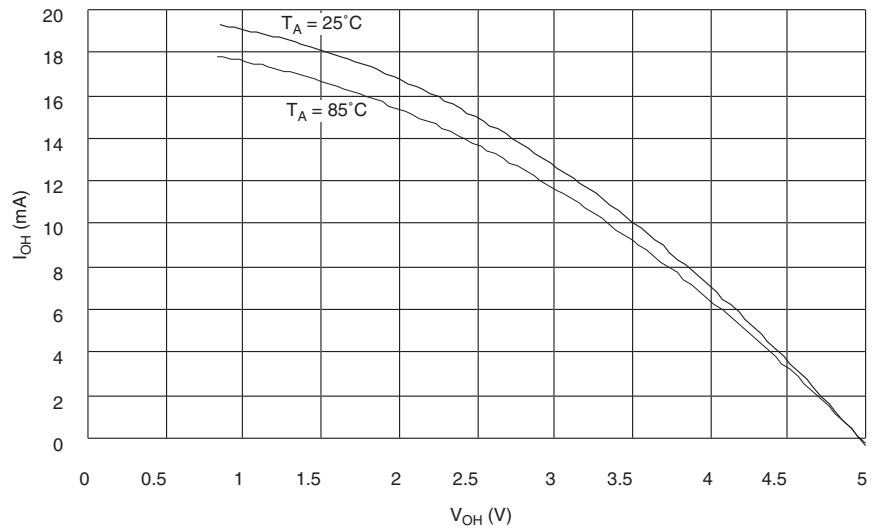
**Figure 58.** Pull-up Resistor Current vs. Input Voltage ( $V_{CC} = 2.7V$ )



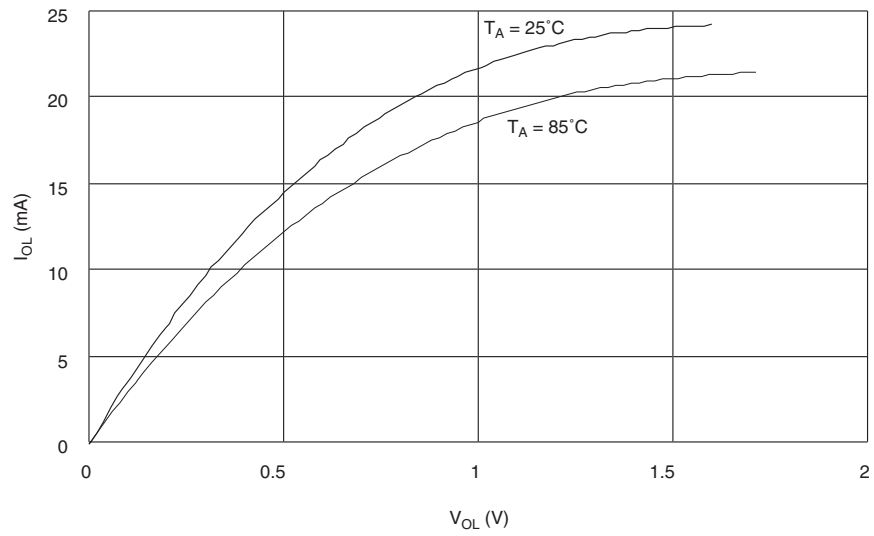
**Figure 59.** I/O Pin Sink Current vs. Output Voltage. All pins except PA2 ( $V_{CC} = 5V$ )



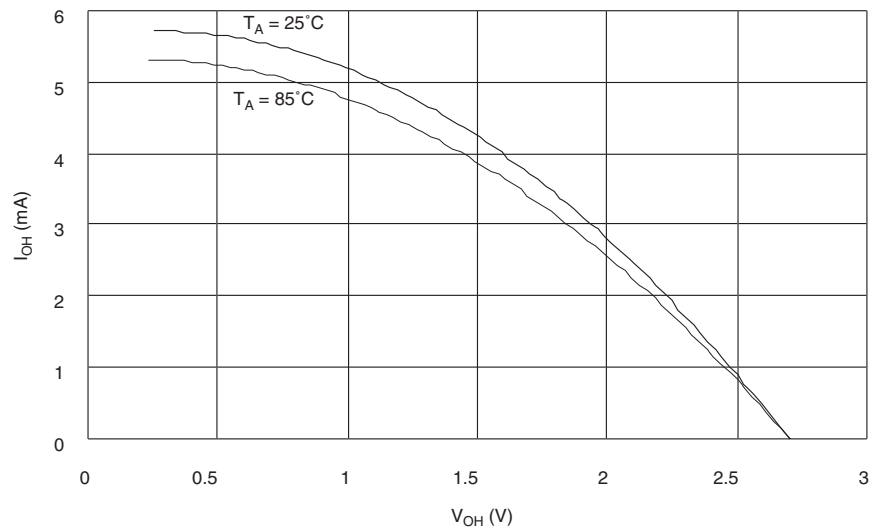
**Figure 60.** I/O Pin Source Current vs. Output voltage ( $V_{CC} = 5V$ )



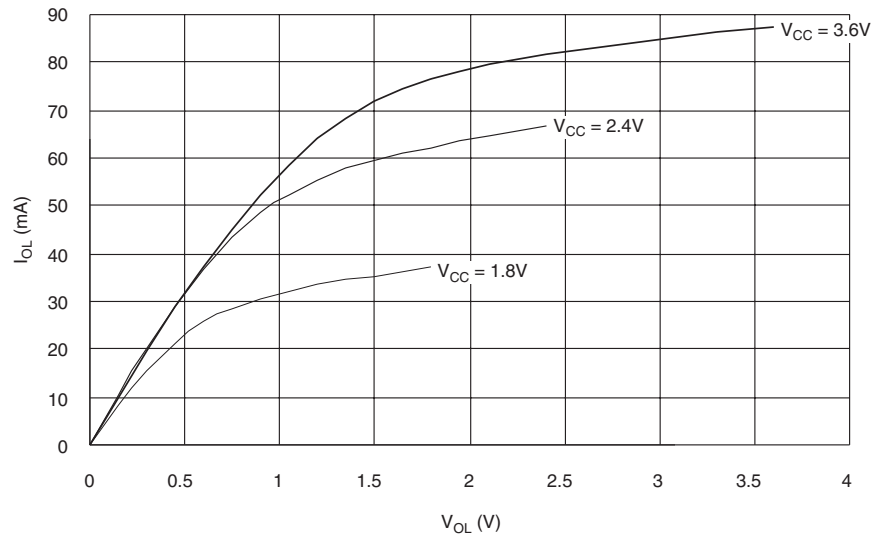
**Figure 61.** I/O Pin Sink Current vs. Output Voltage, All Pins Except PA2 ( $V_{CC} = 2.7V$ )



**Figure 62.** I/O Pin Source Current vs. Output Voltage ( $V_{CC} = 2.7V$ )



**Figure 63.** PA2 I/O Pin Sink Current vs. Output Voltage (High Current Pin PA2;  $T_A = 25^\circ\text{C}$ )



**Figure 64.** I/O Pin Input Threshold Voltage vs.  $V_{CC}$  ( $T_A = 25^\circ\text{C}$ )

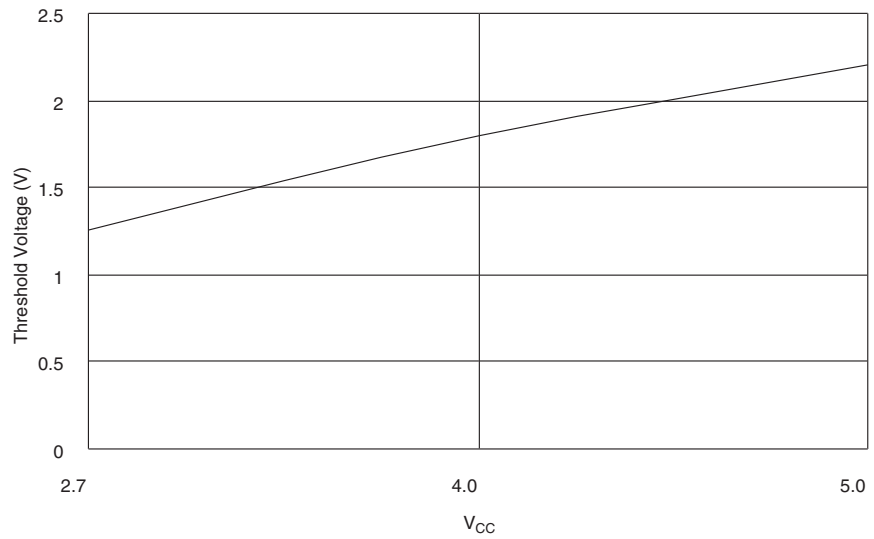
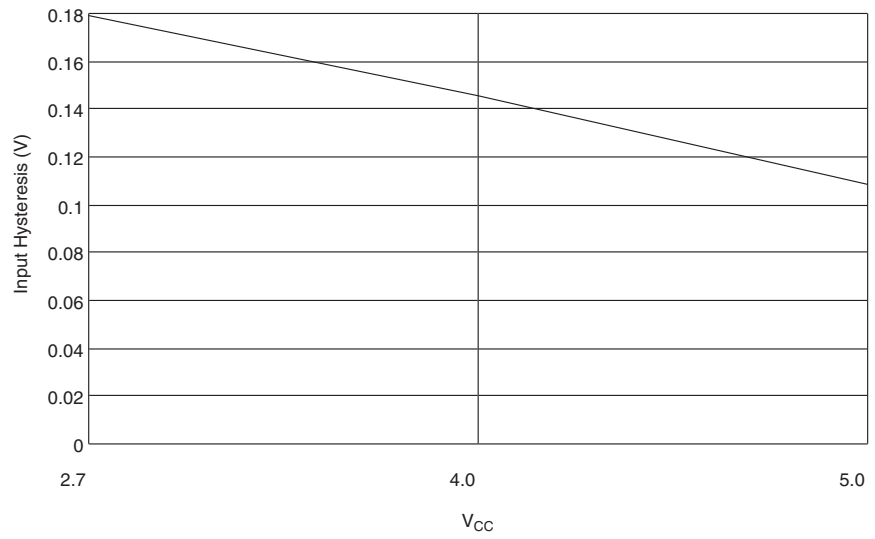


Figure 65. I/O Pin Input Hysteresis vs.  $V_{CC}$  ( $T_A = 25^\circ\text{C}$ )





## Register Summary

Address	Name	Bit 7	Bit 6	Bit 5	Bit 4	Bit 3	Bit 2	Bit 1	Bit 0	Page
\$3F	SREG	I	T	H	S	V	N	Z	C	page 6
\$3E	Reserved									
...	Reserved									
\$20	Reserved									
\$1F	Reserved									
\$1E	Reserved									
\$1D	Reserved									
\$1C	Reserved									
\$1B	PORTA	-	-	-	-	PORTA3	PORTA2	PORTA1	PORTA0	page 32
\$1A	PACR	-	-	-	-	DDA3	PA2HC	DDA1	DDA0	page 32
\$19	PINA	-	-	-	-	PINA3	-	PINA1	PINA0	page 32
\$18	Reserved									
\$17	Reserved									
\$16	PINB	PINB7	PINB6	PINB5	PINB4	PINB3	PINB2	PINB1	PINB0	page 32
\$15	Reserved									
\$14	Reserved									
\$13	Reserved									
\$12	PORTD	PORTD7	PORTD6	PORTD5	PORTD4	PORTD3	PORTD2	PORTD1	PORTD0	page 33
\$11	DDRD	DDD7	DDD6	DDD5	DDD4	DDD3	DDD2	DDD1	DDD0	page 33
\$10	PIND	PIND7	PIND6	PIND5	PIND4	PIND3	PIND2	PIND1	PIND0	page 33
\$0F	Reserved									
\$0E	Reserved									
\$0D	Reserved									
\$0C	Reserved									
\$0B	Reserved									
\$0A	Reserved									
\$09	Reserved									
\$08	ACSR	ACD	-	ACO	ACI	ACIE	-	ACIS1	ACIS0	page 44
\$07	MCUCS	PLUPB	-	SE	SM	WDRF	-	EXTRF	PORF	page 19
\$06	ICR	INT1	INT0	LLIE	TOIE0	ISC11	ISC10	ISC01	ISC00	page 22
\$05	IFR	INTF1	INTF0	-	TOV0	-	-	-	-	page 23
\$04	TCCR0	FOV0	-	-	OOM01	OOM00	CS02	CS01	CS00	page 35
\$03	TCNT0	Timer/Counter0 (8-bit)								page 36
\$02	MODCR	ONTIM4	ONTIM3	ONTIM2	ONTIM1	ONTIM0	MCONF2	MCONF1	MCONF0	page 43
\$01	WDTCSR	-	-	-	WDTOE	WDE	WDP2	WDP1	WDP0	page 37
\$00	OSCCAL	Oscillator Calibration Register								page 9

- Notes:
1. For compatibility with future devices, reserved bits should be written to zero if accessed. Reserved I/O memory addresses should never be written.
  2. Some of the status flags are cleared by writing a logical "1" to them. Note that the CBI and SBI instructions will operate on all bits in the I/O register, writing a one back into any flag read as set, thus clearing the flag. The CBI and SBI instructions work with registers \$00 to \$1F only.

## Instruction Set Summary

Mnemonic	Operands	Description	Operation	Flags	# Clocks
<b>ARITHMETIC AND LOGIC INSTRUCTIONS</b>					
ADD	Rd, Rr	Add Two Registers	$Rd \leftarrow Rd + Rr$	Z,C,N,V,H	1
ADC	Rd, Rr	Add with Carry Two Registers	$Rd \leftarrow Rd + Rr + C$	Z,C,N,V,H	1
SUB	Rd, Rr	Subtract Two Registers	$Rd \leftarrow Rd - Rr$	Z,C,N,V,H	1
SUBI	Rd, K	Subtract Constant from Register	$Rd \leftarrow Rd - K$	Z,C,N,V,H	1
SBC	Rd, Rr	Subtract with Carry Two Registers	$Rd \leftarrow Rd - Rr - C$	Z,C,N,V,H	1
SBCI	Rd, K	Subtract with Carry Constant from Reg.	$Rd \leftarrow Rd - K - C$	Z,C,N,V,H	1
AND	Rd, Rr	Logical AND Registers	$Rd \leftarrow Rd \cdot Rr$	Z,N,V	1
ANDI	Rd, K	Logical AND Register and Constant	$Rd \leftarrow Rd \cdot K$	Z,N,V	1
OR	Rd, Rr	Logical OR Registers	$Rd \leftarrow Rd \vee Rr$	Z,N,V	1
ORI	Rd, K	Logical OR Register and Constant	$Rd \leftarrow Rd \vee K$	Z,N,V	1
EOR	Rd, Rr	Exclusive OR Registers	$Rd \leftarrow Rd \oplus Rr$	Z,N,V	1
COM	Rd	One's Complement	$Rd \leftarrow \text{\$FF} - Rd$	Z,C,N,V	1
NEG	Rd	Two's Complement	$Rd \leftarrow \text{\$00} - Rd$	Z,C,N,V,H	1
SBR	Rd, K	Set Bit(s) in Register	$Rd \leftarrow Rd \vee K$	Z,N,V	1
CBR	Rd, K	Clear Bit(s) in Register	$Rd \leftarrow Rd \cdot (\text{\$FF} - K)$	Z,N,V	1
INC	Rd	Increment	$Rd \leftarrow Rd + 1$	Z,N,V	1
DEC	Rd	Decrement	$Rd \leftarrow Rd - 1$	Z,N,V	1
TST	Rd	Test for Zero or Minus	$Rd \leftarrow Rd \cdot Rd$	Z,N,V	1
CLR	Rd	Clear Register	$Rd \leftarrow Rd \oplus Rd$	Z,N,V	1
SER	Rd	Set Register	$Rd \leftarrow \text{\$FF}$	None	1
<b>BRANCH INSTRUCTIONS</b>					
RJMP	k	Relative Jump	$PC \leftarrow PC + k + 1$	None	2
RCALL	k	Relative Subroutine Call	$PC \leftarrow PC + k + 1$	None	3
RET		Subroutine Return	$PC \leftarrow \text{STACK}$	None	4
RETI		Interrupt Return	$PC \leftarrow \text{STACK}$	I	4
CPSE	Rd, Rr	Compare, Skip if Equal	if (Rd = Rr) $PC \leftarrow PC + 2$ or 3	None	1/2
CP	Rd, Rr	Compare	$Rd - Rr$	Z,N,V,C,H	1
CPC	Rd, Rr	Compare with Carry	$Rd - Rr - C$	Z,N,V,C,H	1
CPI	Rd, K	Compare Register with Immediate	$Rd - K$	Z,N,V,C,H	1
SBRC	Rr, b	Skip if Bit in Register Cleared	if (Rr(b) = 0) $PC \leftarrow PC + 2$ or 3	None	1/2
SBRS	Rr, b	Skip if Bit in Register is Set	if (Rr(b) = 1) $PC \leftarrow PC + 2$ or 3	None	1/2
SBIC	P, b	Skip if Bit in I/O Register Cleared	if (P(b) = 0) $PC \leftarrow PC + 2$ or 3	None	1/2
SBIS	P, b	Skip if Bit in I/O Register is Set	if (P(b) = 1) $PC \leftarrow PC + 2$ or 3	None	1/2
BRBS	s, k	Branch if Status Flag Set	if (SREG(s) = 1) then $PC \leftarrow PC + k + 1$	None	1/2
BRBC	s, k	Branch if Status Flag Cleared	if (SREG(s) = 0) then $PC \leftarrow PC + k + 1$	None	1/2
BREQ	k	Branch if Equal	if (Z = 1) then $PC \leftarrow PC + k + 1$	None	1/2
BRNE	k	Branch if Not Equal	if (Z = 0) then $PC \leftarrow PC + k + 1$	None	1/2
BRCS	k	Branch if Carry Set	if (C = 1) then $PC \leftarrow PC + k + 1$	None	1/2
BRCC	k	Branch if Carry Cleared	if (C = 0) then $PC \leftarrow PC + k + 1$	None	1/2
BRSH	k	Branch if Same or Higher	if (C = 0) then $PC \leftarrow PC + k + 1$	None	1/2
BRLO	k	Branch if Lower	if (C = 1) then $PC \leftarrow PC + k + 1$	None	1/2
BRMI	k	Branch if Minus	if (N = 1) then $PC \leftarrow PC + k + 1$	None	1/2
BRPL	k	Branch if Plus	if (N = 0) then $PC \leftarrow PC + k + 1$	None	1/2
BRGE	k	Branch if Greater or Equal, Signed	if (N $\oplus$ V = 0) then $PC \leftarrow PC + k + 1$	None	1/2
BRLT	k	Branch if Less than Zero, Signed	if (N $\oplus$ V = 1) then $PC \leftarrow PC + k + 1$	None	1/2
BRHS	k	Branch if Half-carry Flag Set	if (H = 1) then $PC \leftarrow PC + k + 1$	None	1/2
BRHC	k	Branch if Half-carry Flag Cleared	if (H = 0) then $PC \leftarrow PC + k + 1$	None	1/2
BRTS	k	Branch if T-flag Set	if (T = 1) then $PC \leftarrow PC + k + 1$	None	1/2
BRTC	k	Branch if T-flag Cleared	if (T = 0) then $PC \leftarrow PC + k + 1$	None	1/2
BRVS	k	Branch if Overflow Flag is Set	if (V = 1) then $PC \leftarrow PC + k + 1$	None	1/2
BRVC	k	Branch if Overflow Flag is Cleared	if (V = 0) then $PC \leftarrow PC + k + 1$	None	1/2
BRIE	k	Branch if Interrupt Enabled	if (I = 1) then $PC \leftarrow PC + k + 1$	None	1/2
BRID	k	Branch if Interrupt Disabled	if (I = 0) then $PC \leftarrow PC + k + 1$	None	1/2



## Instruction Set Summary (Continued)

Mnemonic	Operands	Description	Operation	Flags	# Clocks
<b>DATA TRANSFER INSTRUCTIONS</b>					
LD	Rd, Z	Load Register Indirect	$Rd \leftarrow (Z)$	None	2
ST	Z, Rr	Store Register Indirect	$(Z) \leftarrow Rr$	None	2
MOV	Rd, Rr	Move between Registers	$Rd \leftarrow Rr$	None	1
LDI	Rd, K	Load Immediate	$Rd \leftarrow K$	None	1
IN	Rd, P	In Port	$Rd \leftarrow P$	None	1
OUT	P, Rr	Out Port	$P \leftarrow Rr$	None	1
LPM		Load Program Memory	$R0 \leftarrow (Z)$	None	3
<b>BIT AND BIT-TEST INSTRUCTIONS</b>					
SBI	P, b	Set Bit in I/O Register	$I/O(P,b) \leftarrow 1$	None	2
CBI	P, b	Clear Bit in I/O Register	$I/O(P,b) \leftarrow 0$	None	2
LSL	Rd	Logical Shift Left	$Rd(n+1) \leftarrow Rd(n), Rd(0) \leftarrow 0$	Z,C,N,V	1
LSR	Rd	Logical Shift Right	$Rd(n) \leftarrow Rd(n+1), Rd(7) \leftarrow 0$	Z,C,N,V	1
ROL	Rd	Rotate Left through Carry	$Rd(0) \leftarrow C, Rd(n+1) \leftarrow Rd(n), C \leftarrow Rd(7)$	Z,C,N,V	1
ROR	Rd	Rotate Right through Carry	$Rd(7) \leftarrow C, Rd(n) \leftarrow Rd(n+1), C \leftarrow Rd(0)$	Z,C,N,V	1
ASR	Rd	Arithmetic Shift Right	$Rd(n) \leftarrow Rd(n+1), n = 0..6$	Z,C,N,V	1
SWAP	Rd	Swap Nibbles	$Rd(3..0) \leftarrow Rd(7..4), Rd(7..4) \leftarrow Rd(3..0)$	None	1
BSET	s	Flag Set	$SREG(s) \leftarrow 1$	SREG(s)	1
BCLR	s	Flag Clear	$SREG(s) \leftarrow 0$	SREG(s)	1
BST	Rr, b	Bit Store from Register to T	$T \leftarrow Rr(b)$	T	1
BLD	Rd, b	Bit Load from T to Register	$Rd(b) \leftarrow T$	None	1
SEC		Set Carry	$C \leftarrow 1$	C	1
CLC		Clear Carry	$C \leftarrow 0$	C	1
SEN		Set Negative Flag	$N \leftarrow 1$	N	1
CLN		Clear Negative Flag	$N \leftarrow 0$	N	1
SEZ		Set Zero Flag	$Z \leftarrow 1$	Z	1
CLZ		Clear Zero Flag	$Z \leftarrow 0$	Z	1
SEI		Global Interrupt Enable	$I \leftarrow 1$	I	1
CLI		Global Interrupt Disable	$I \leftarrow 0$	I	1
SES		Set Signed Test Flag	$S \leftarrow 1$	S	1
CLS		Clear Signed Test Flag	$S \leftarrow 0$	S	1
SEV		Set Two's Complement Overflow	$V \leftarrow 1$	V	1
CLV		Clear Two's Complement Overflow	$V \leftarrow 0$	V	1
SET		Set T in SREG	$T \leftarrow 1$	T	1
CLT		Clear T in SREG	$T \leftarrow 0$	T	1
SEH		Set Half-carry Flag in SREG	$H \leftarrow 1$	H	1
CLH		Clear Half-carry Flag in SREG	$H \leftarrow 0$	H	1
NOP		No Operation		None	1
SLEEP		Sleep	(see specific descr. for Sleep function)	None	1
WDR		Watchdog Reset	(see specific descr. for WDR/timer)	None	1



## Ordering Information

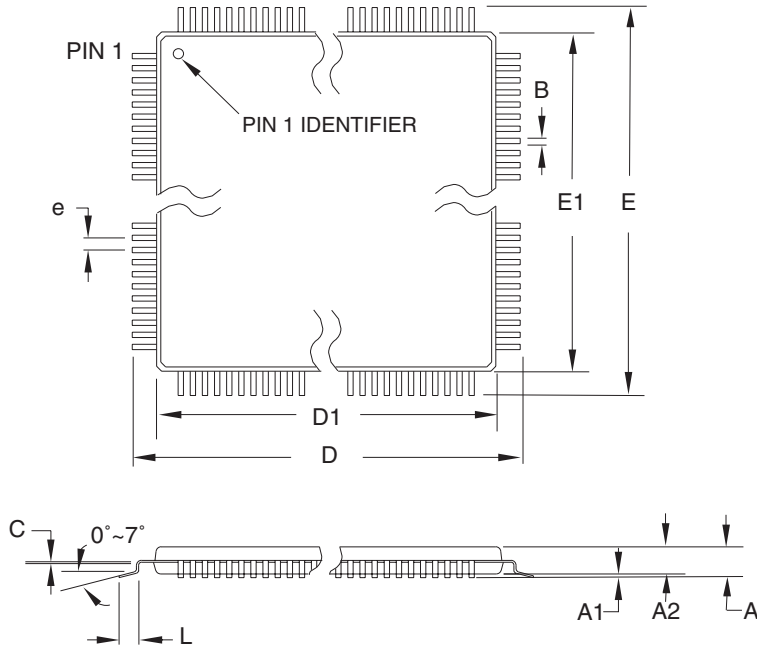
Speed (MHz)	Power Supply (Volts)	Ordering Code	Package <sup>(1)</sup>	Operation Range
4	2.7 - 5.5	ATtiny28L-4AC	32A	Commercial (0°C to 70°C)
		ATtiny28L-4PC	28P3	
		ATtiny28L-4MC	32M1-A	
		ATtiny28L-4AI	32A	Industrial (-40°C to 85°C)
		ATtiny28L-4AU <sup>(2)</sup>	32A	
		ATtiny28L-4PI	28P3	
ATtiny28L-4PU <sup>(2)</sup>	28P3			
ATtiny28L-4MI	32M1-A			
ATtiny28L-4MU <sup>(2)</sup>	32M1-A			
1.2	1.8 - 5.5	ATtiny28V-1AC	32A	Commercial (0°C to 70°C)
		ATtiny28V-1PC	28P3	
		ATtiny28V-1MC	32M1-A	
		ATtiny28V-1AI	32A	Industrial (-40°C to 85°C)
		ATtiny28V-1AU <sup>(2)</sup>	32A	
		ATtiny28V-1PI	28P3	
ATtiny28V-1PU <sup>(2)</sup>	28P3			
ATtiny28V-1MI	32M1-A			
ATtiny28V-1MU <sup>(2)</sup>	32M1-A			

- Notes:
1. This device can also be supplied in wafer form. Please contact your local Atmel sales office for detailed ordering information and minimum quantities.
  2. Pb-free packaging alternative, complies to the European Directive for Restriction of Hazardous Substances (RoHS directive). Also Halide free and fully Green.

Package Type	
<b>32A</b>	32-lead, Thin (1.0 mm) Plastic Quad Flat Package (TQFP)
<b>28P3</b>	28-lead, 0.300" Wide, Plastic Dual Inline Package (PDIP)
<b>32M1-A</b>	32-pad, 5x5x1.0 body, Lead Pitch 0.50mm, Quad Flat No-lead/Micro Lead Frame Package (QFN/MLF)

# Packaging Information

32A



**COMMON DIMENSIONS**  
(Unit of Measure = mm)

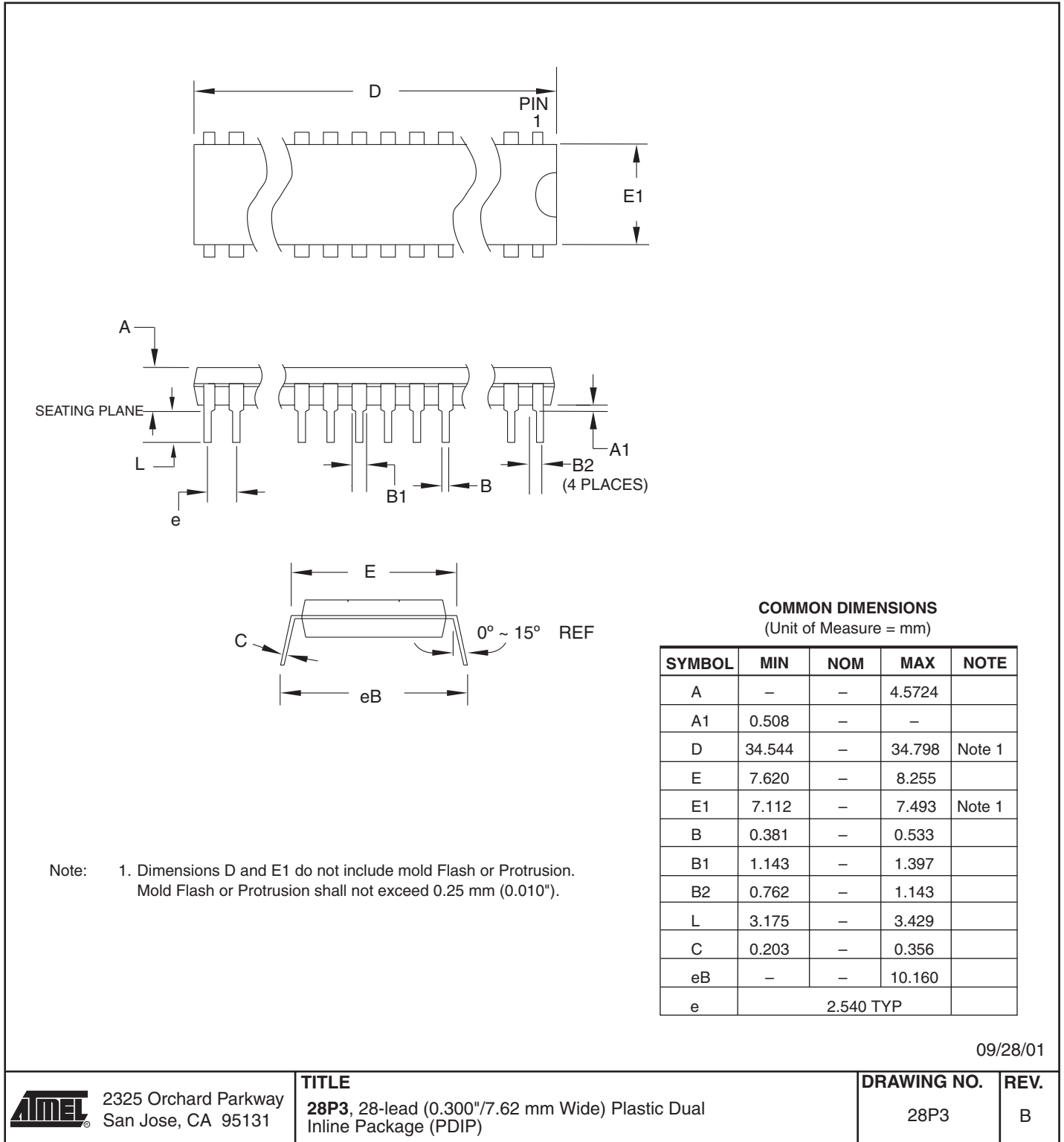
SYMBOL	MIN	NOM	MAX	NOTE
A	–	–	1.20	
A1	0.05	–	0.15	
A2	0.95	1.00	1.05	
D	8.75	9.00	9.25	
D1	6.90	7.00	7.10	Note 2
E	8.75	9.00	9.25	
E1	6.90	7.00	7.10	Note 2
B	0.30	–	0.45	
C	0.09	–	0.20	
L	0.45	–	0.75	
e	0.80 TYP			

- Notes:
1. This package conforms to JEDEC reference MS-026, Variation ABA.
  2. Dimensions D1 and E1 do not include mold protrusion. Allowable protrusion is 0.25 mm per side. Dimensions D1 and E1 are maximum plastic body size dimensions including mold mismatch.
  3. Lead coplanarity is 0.10 mm maximum.

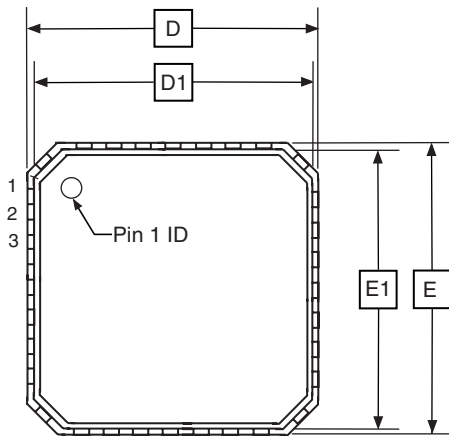
10/5/2001

2325 Orchard Parkway San Jose, CA 95131	<b>TITLE</b>	<b>DRAWING NO.</b>	<b>REV.</b>
	<b>32A</b> , 32-lead, 7 x 7 mm Body Size, 1.0 mm Body Thickness, 0.8 mm Lead Pitch, Thin Profile Plastic Quad Flat Package (TQFP)	32A	B

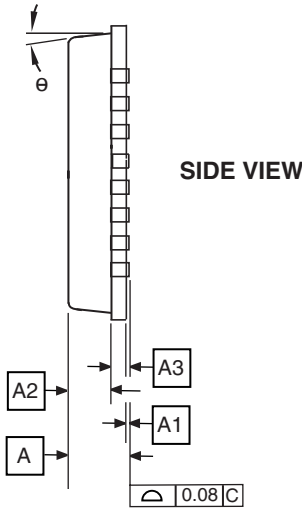
## 28P3



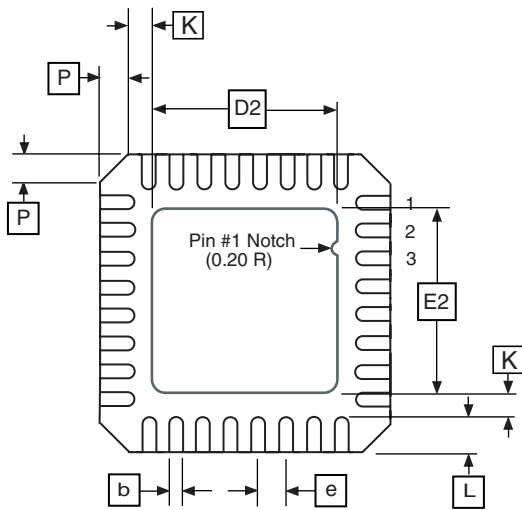
# 32M1-A



**TOP VIEW**



**SIDE VIEW**



**BOTTOM VIEW**

**COMMON DIMENSIONS**  
(Unit of Measure = mm)

SYMBOL	MIN	NOM	MAX	NOTE
A	0.80	0.90	1.00	
A1	-	0.02	0.05	
A2	-	0.65	1.00	
A3	0.20 REF			
b	0.18	0.23	0.30	
D	4.90	5.00	5.10	
D1	4.70	4.75	4.80	
D2	2.95	3.10	3.25	
E	4.90	5.00	5.10	
E1	4.70	4.75	4.80	
E2	2.95	3.10	3.25	
e	0.50 BSC			
L	0.30	0.40	0.50	
P	-	-	0.60	
$\theta$	-	-	12°	
K	0.20	-	-	

Note: JEDEC Standard MO-220, Fig. 2 (Anvil Singulation), VHHD-2.

5/25/06



2325 Orchard Parkway  
San Jose, CA 95131

**TITLE**

**32M1-A**, 32-pad, 5 x 5 x 1.0 mm Body, Lead Pitch 0.50 mm,  
3.10 mm Exposed Pad, Micro Lead Frame Package (MLF)

**DRAWING NO.**

32M1-A

**REV.**

E

## **Errata**

### **All revisions**

No known errata.

## Datasheet Revision History

Please note that the referring page numbers in this section are referred to this document. The referring revision in this section are referring to the document revision.

### Rev – 01/06G

1. Updated chapter layout.
2. Updated “Ordering Information” on page 73.

### Rev – 01/06G

1. Updated description for “Port A” on page 25.
2. Added note 6 in “DC Characteristics” on page 54.
3. Updated “Ordering Information” on page 73.
4. Added “Errata” on page 77.

### Rev – 03/05F

1. Updated “Electrical Characteristics” on page 54.
2. MLF-package alternative changed to “Quad Flat No-Lead/Micro Lead Frame Package QFN/MLF”.
3. Updated “Ordering Information” on page 73.

<b>Table of Contents</b>	<b>Features.....</b>	<b>1</b>
	<b>Pin Configurations.....</b>	<b>1</b>
	<b>Description .....</b>	<b>2</b>
	Block Diagram .....	2
	Pin Descriptions.....	3
	Clock Options .....	4
	<b>Architectural Overview.....</b>	<b>6</b>
	General-purpose Register File.....	7
	ALU – Arithmetic Logic Unit.....	7
	Downloadable Flash Program Memory .....	7
	Program and Data Addressing Modes.....	7
	Subroutine and Interrupt Hardware Stack .....	10
	Memory Access and Instruction Execution Timing.....	10
	I/O Memory .....	11
	Reset and Interrupt Handling.....	12
	Sleep Modes.....	21
	<b>Timer/Counter0 .....</b>	<b>24</b>
	Timer/Counter Prescaler.....	24
	<b>Watchdog Timer.....</b>	<b>27</b>
	<b>Calibrated Internal RC Oscillator .....</b>	<b>29</b>
	<b>Hardware Modulator .....</b>	<b>30</b>
	<b>Analog Comparator .....</b>	<b>35</b>
	<b>I/O Ports.....</b>	<b>37</b>
	Port A.....	37
	Port B.....	40
	Port D.....	43
	<b>Memory Programming.....</b>	<b>45</b>
	Program Memory Lock Bits .....	45
	Fuse Bits.....	45
	Signature Bytes .....	45
	Calibration Byte .....	45
	Programming the Flash .....	45
	Parallel Programming .....	46
	<b>Parallel Programming Characteristics.....</b>	<b>52</b>



<b>Electrical Characteristics</b> .....	<b>53</b>
Absolute Maximum Ratings .....	53
DC Characteristics .....	53
External Clock Drive Waveforms .....	55
External Clock Drive .....	55
<b>Typical Characteristics</b> .....	<b>56</b>
<b>Register Summary</b> .....	<b>69</b>
<b>Instruction Set Summary</b> .....	<b>70</b>
<b>Ordering Information</b> .....	<b>72</b>
<b>Packaging Information</b> .....	<b>74</b>
32A .....	74
28P3 .....	75
32M1-A .....	76
<b>Errata</b> .....	<b>77</b>
All revisions.....	77
<b>Datasheet Revision History</b> .....	<b>78</b>
Rev – 01/06G.....	78
Rev – 03/05F .....	78
<b>Table of Contents</b> .....	<b>i</b>





## Atmel Corporation

2325 Orchard Parkway  
San Jose, CA 95131, USA  
Tel: 1(408) 441-0311  
Fax: 1(408) 487-2600

## Regional Headquarters

### Europe

Atmel Sarl  
Route des Arsenalux 41  
Case Postale 80  
CH-1705 Fribourg  
Switzerland  
Tel: (41) 26-426-5555  
Fax: (41) 26-426-5500

### Asia

Room 1219  
Chinachem Golden Plaza  
77 Mody Road Tsimshatsui  
East Kowloon  
Hong Kong  
Tel: (852) 2721-9778  
Fax: (852) 2722-1369

### Japan

9F, Tonetsu Shinkawa Bldg.  
1-24-8 Shinkawa  
Chuo-ku, Tokyo 104-0033  
Japan  
Tel: (81) 3-3523-3551  
Fax: (81) 3-3523-7581

## Atmel Operations

### Memory

2325 Orchard Parkway  
San Jose, CA 95131, USA  
Tel: 1(408) 441-0311  
Fax: 1(408) 436-4314

### Microcontrollers

2325 Orchard Parkway  
San Jose, CA 95131, USA  
Tel: 1(408) 441-0311  
Fax: 1(408) 436-4314

La Chantrerie  
BP 70602  
44306 Nantes Cedex 3, France  
Tel: (33) 2-40-18-18-18  
Fax: (33) 2-40-18-19-60

### ASIC/ASSP/Smart Cards

Zone Industrielle  
13106 Rousset Cedex, France  
Tel: (33) 4-42-53-60-00  
Fax: (33) 4-42-53-60-01

1150 East Cheyenne Mtn. Blvd.  
Colorado Springs, CO 80906, USA  
Tel: 1(719) 576-3300  
Fax: 1(719) 540-1759

Scottish Enterprise Technology Park  
Maxwell Building  
East Kilbride G75 0QR, Scotland  
Tel: (44) 1355-803-000  
Fax: (44) 1355-242-743

### RF/Automotive

Theresienstrasse 2  
Postfach 3535  
74025 Heilbronn, Germany  
Tel: (49) 71-31-67-0  
Fax: (49) 71-31-67-2340

1150 East Cheyenne Mtn. Blvd.  
Colorado Springs, CO 80906, USA  
Tel: 1(719) 576-3300  
Fax: 1(719) 540-1759

### Biometrics/Imaging/Hi-Rel MPU/ High Speed Converters/RF Datacom

Avenue de Rochepleine  
BP 123  
38521 Saint-Egreve Cedex, France  
Tel: (33) 4-76-58-30-00  
Fax: (33) 4-76-58-34-80

---

## Literature Requests

[www.atmel.com/literature](http://www.atmel.com/literature)

**Disclaimer:** The information in this document is provided in connection with Atmel products. No license, express or implied, by estoppel or otherwise, to any intellectual property right is granted by this document or in connection with the sale of Atmel products. **EXCEPT AS SET FORTH IN ATMEL'S TERMS AND CONDITIONS OF SALE LOCATED ON ATMEL'S WEB SITE, ATMEL ASSUMES NO LIABILITY WHATSOEVER AND DISCLAIMS ANY EXPRESS, IMPLIED OR STATUTORY WARRANTY RELATING TO ITS PRODUCTS INCLUDING, BUT NOT LIMITED TO, THE IMPLIED WARRANTY OF MERCHANTABILITY, FITNESS FOR A PARTICULAR PURPOSE, OR NON-INFRINGEMENT. IN NO EVENT SHALL ATMEL BE LIABLE FOR ANY DIRECT, INDIRECT, CONSEQUENTIAL, PUNITIVE, SPECIAL OR INCIDENTAL DAMAGES (INCLUDING, WITHOUT LIMITATION, DAMAGES FOR LOSS OF PROFITS, BUSINESS INTERRUPTION, OR LOSS OF INFORMATION) ARISING OUT OF THE USE OR INABILITY TO USE THIS DOCUMENT, EVEN IF ATMEL HAS BEEN ADVISED OF THE POSSIBILITY OF SUCH DAMAGES.** Atmel makes no representations or warranties with respect to the accuracy or completeness of the contents of this document and reserves the right to make changes to specifications and product descriptions at any time without notice. Atmel does not make any commitment to update the information contained herein. Unless specifically provided otherwise, Atmel products are not suitable for, and shall not be used in, automotive applications. Atmel's products are not intended, authorized, or warranted for use as components in applications intended to support or sustain life.

© Atmel Corporation 2006. All rights reserved. Atmel®, logo and combinations thereof, Everywhere You Are®, AVR®, AVR Studio®, and others, are registered trademarks or trademarks of Atmel Corporation or its subsidiaries. Other terms and product names may be trademarks of others.



Printed on recycled paper.

1062F-AVR-07/06