

150mA Low-Noise LDO in SOT23-5

DESCRIPTION

The EUP7915 is an efficient, CMOS voltage regulator optimized for ultra-low-noise applications. It offers high output accuracy, extremely low dropout voltage, low ground current and fast start-up time. The EUP7915 provides a very low noise output, ideal for RF applications where a clean voltage source is required. A noise bypass pin is also available for further reduction of output noise.

Designed specifically for handheld and battery-powered devices, the EUP7915 provides a TTL-logic-compatible enable pin. When disabled, power consumption drops nearly to zero.

The EUP7915 also works with low-ESR ceramic capacitors, reducing the amount of board space necessary for power applications, critical in handheld wireless devices.

Available in the SOT23-5 package, the EUP7915 offers a wide range of output voltages. Key features include current limit, thermal shutdown and faster transient response.

FEATURES

- 5-pin SOT23-5 Package
- 2.5V to 5.5V Input Voltage Range
- 50 μ V(rms) Output Noise
- 140mV Dropout @ 150mA
- 75dB PSRR at 1kHz
- Low 70 μ A Ground Current
- 150mA Output Current
- Stability with 1 μ F Ceramic Output Capacitors
- Excellent Load/Line Transient
- Thermal Shutdown and Current Limit Protection
- Available in 1.2V, 1.5V, 1.8V, 2.5V, 2.8V, 2.85V, 2.9V, 3.0V, 3.3V, 4.8V and Adjustable Voltages
- RoHS Compliant and 100% Lead (Pb)-Free

APPLICATIONS

- Cellular Phones
- Bluetooth Portable Radios and Accessories
- PDA and Palmtop Computers
- Consumer/Personal Electronics

Block Diagram

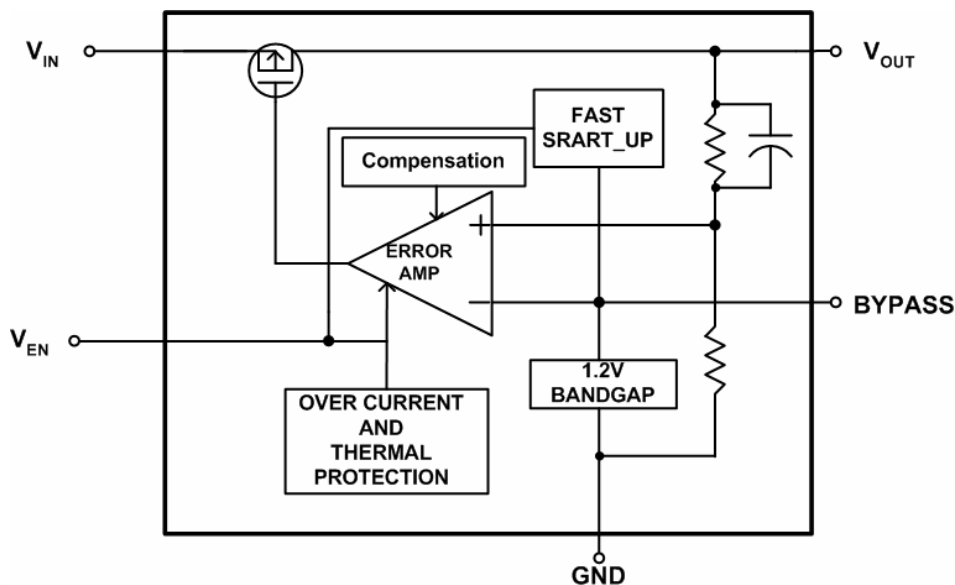

Figure 1. Fixed-Voltage

Block Diagram (Continued)

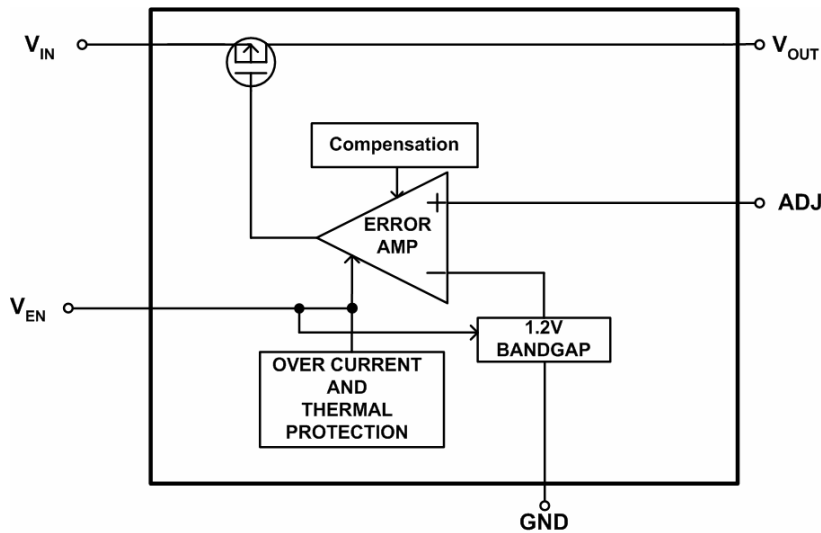

Figure 2. Adjustable Voltage

Typical Application Circuit

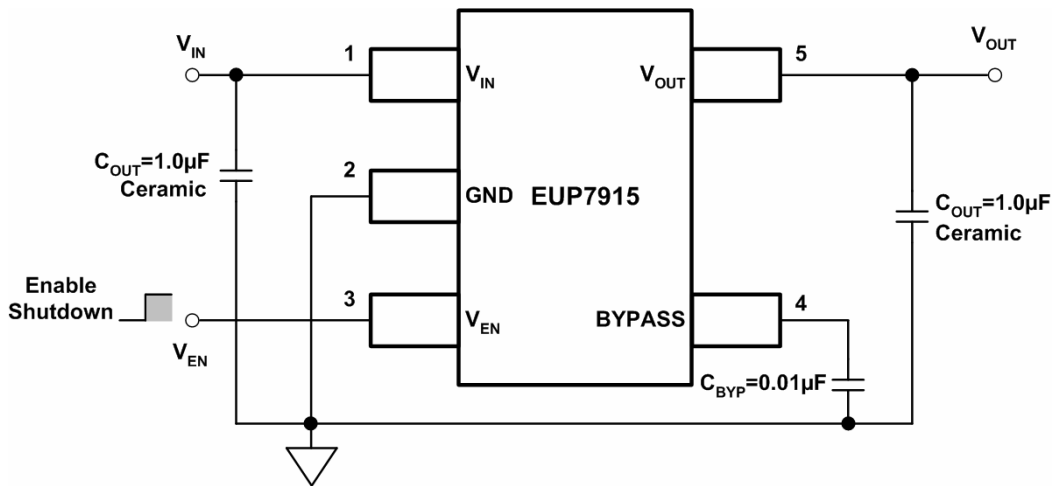

Figure 3. Fixed Output Voltage Regulator

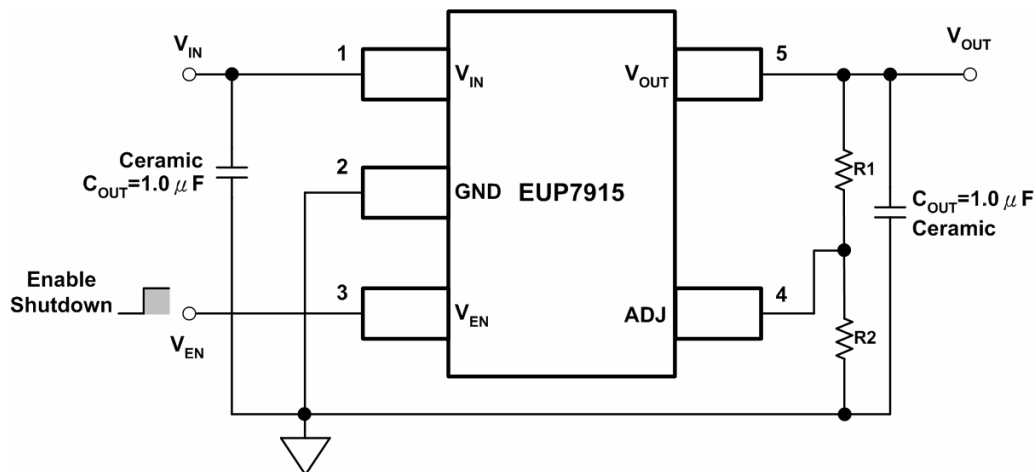
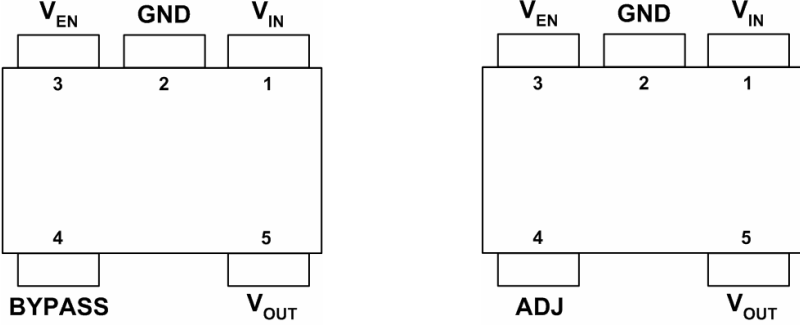

Figure 4. Adjustable Voltage Regulator

Pin Configurations

Package Type	Pin Configurations
SOT23-5	 <p>Fixed-Voltage</p> <p>Adjustable Voltage</p>

Pin Description

PIN	PIN	DESCRIPTION
V_{IN}	1	Input voltage of the LDO
GND	2	Common ground
V_{EN}	3	Enable input logic, enable high
BYPASS	4	Optional bypass capacitor for noise reduction
ADJ		Adjustable regulator feedback input. Connect to resistor divider.
V_{OUT}	5	Output voltage of the LDO

Ordering Information

Order Number	Package Type	Marking	Operating Temperature Range
EUP7915-12VIR1	SOT23-5	ZT	-40 °C to 125°C
EUP7915-15VIR1	SOT23-5	ZC	-40 °C to 125°C
EUP7915-18VIR1	SOT23-5	ZD	-40 °C to 125°C
EUP7915-25VIR1	SOT23-5	ZB	-40 °C to 125°C
EUP7915-28VIR1	SOT23-5	ZE	-40 °C to 125°C
EUP7915-285VIR1	SOT23-5	ZF	-40 °C to 125°C
EUP7915-29VIR1	SOT23-5	ZW	-40 °C to 125°C
EUP7915-30VIR1	SOT23-5	ZG	-40 °C to 125°C
EUP7915-33VIR1	SOT23-5	ZH	-40 °C to 125°C
EUP7915-48VIR1	SOT23-5	ZK	-40 °C to 125°C
EUP7915VIR1	SOT23-5	ZA	-40 °C to 125°C

EUP7915-

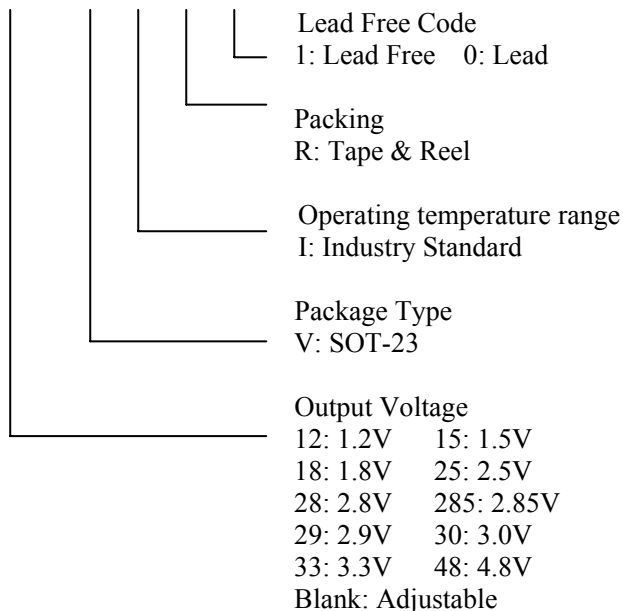

Absolute Maximum Ratings

- V_{IN}, V_{EN} ----- -0.3 to 6V
- V_{OUT} ----- -0.3 to $(V_{IN}+0.3) \leq 6V$
- Junction Temperature ----- 150°C
- Storage Temperature Range ----- -65°C to +150°C
- Lead Temperature ----- 260°C
- Maximum Power Dissipation ----- 0.3W
- Thermal Resistance θ_{JA} ----- 320°C/W
- ESD Rating
Human Body Model ----- 2kV

Operating Ratings

- V_{IN} ----- 2.5 to 5.5V
- V_{EN} ----- 0 to $(V_{IN}+0.3) \leq 5.5V$
- Operating Temperature Range ----- -40°C to +125°C

Electrical Characteristics

Conditions: $V_{IN}=V_{OUT}+0.2V$ if $V_{OUT} \geq 2.5V$, $V_{IN}=2.5V$ if $V_{OUT}<2.5V$, $V_{EN}=V_{IN}$, $C_{IN}=1\mu F$, $C_{OUT}=1\mu F$, $T_A=-40\sim 85$
 Unless otherwise specified. Typical values are at 25 °C.

Symbol	Parameter	Conditions	EUP7915			Unit
			Min	Typ	Max.	
	Input Voltage		2.5		5.5	V
ΔV_{OUT}	Output Voltage Accuracy	$I_{OUT}=1mA, T_A=25$	-2		2	%
		$I_{OUT}=1mA, T_A=-40 \text{ to } 85$	-3		3	%
I_{OUTMAX}	Maximum Output Current	$T_A>0, V_{IN}=V_{OUT} + 0.2V$ for $V_{OUT} > 3.3V$ or $V_{IN}=V_{OUT}+0.5V$	150			mA
I_{LIMIT}	Current Limit	$V_{OUT}=V_{OUT(nom)} \times 90\%, T_A>0$	160	220	400	mA
V_{DROP}	Dropout Voltage (Note1)	$I_{OUT}=150mA, V_{OUT}<3.3V$		140	240	mV
		$I_{OUT}=100mA, V_{OUT}>3.3V$		60	100	
I_Q	Quiescent Current	$I_{OUT}=1mA$		70	160	μA
V_{LNR}	Line Regulation	$V_{IN}=(V_{OUT}+0.2V)$ to 5.5V, $I_{OUT}=1mA$		0.02	0.25	%/V
V_{LDR}	Load Regulation	$1mA \leq I_{OUT} \leq 100mA$ ($V_{IN}=V_{OUT} + 0.2V$)		0.002	0.013	%/mA
		$1mA \leq I_{OUT} \leq 150mA$ ($V_{IN}=V_{OUT} + 0.5V$)				
I_{SHDN}	Shutdown Supply Current	$V_{EN}=0, T_A=25$			1	μA
PSRR	Power Supply Ripple Rejection	$V_{IN}=(V_{OUT}+1V)DC+0.5V_{P-P}$ $f=1kHz$, $I_{LOAD}=10mA$		75		dB
	Output Noise Voltage (Bypass)	$f=10Hz\sim 100kHz, I_{LOAD}=10mA$		50		μV
	Output Noise Voltage (ADJ)	$f=10Hz\sim 100kHz, I_{LOAD}=10mA$		239		μV
	Turn-on Time (Note2)	$R_{LOAD}=50\Omega, T_A=25$			200	μs
V_{ENL}	VENL (Maximum Low Level Input Voltage at EN)	$V_{IN}=2.5V$ to 5.5V			0.4	V
V_{ENH}	VENH (Minimum high Level Input Voltage at EN)	$V_{IN}=2.5V$ to 5.5V	1.5			V
	VEN Input Bias Current	$V_{IN}=5.5V, V_{EN}=0$ or 5.5V		1		nA
	FB Input Bias Current (ADJ Version)	$V_{IN}=5.5V, V_{FB}=1.3V$		1		nA
V_{FB}	FB Pin Voltage (ADJ Version)	$T_A=25$	1.176	1.2	1.224	V
T_{SD}	Thermal Shutdown Temperature			155		
ΔT_{SD}	Thermal Shutdown Hysteresis			15		

Note 1: The dropout voltage is defined as $V_{IN}-V_{OUT}$ when V_{OUT} is 100mV below the nominal value of V_{OUT} .

Note 2: Test time needed for V_{OUT} to reach 90% of final value.

Typical Operating Characteristics

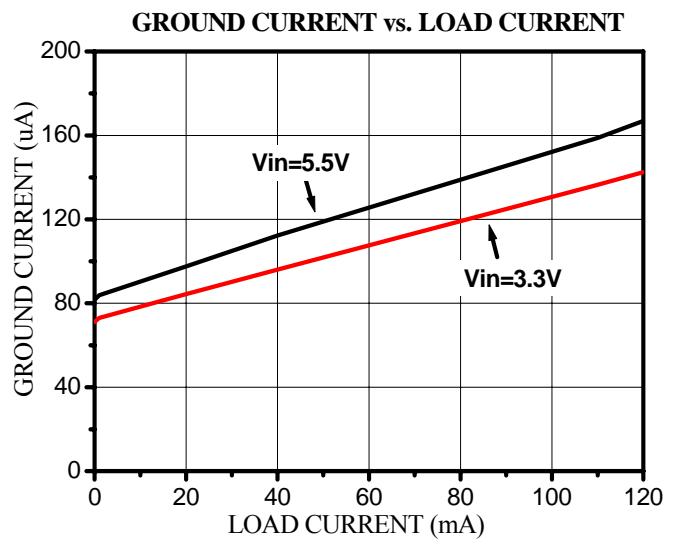
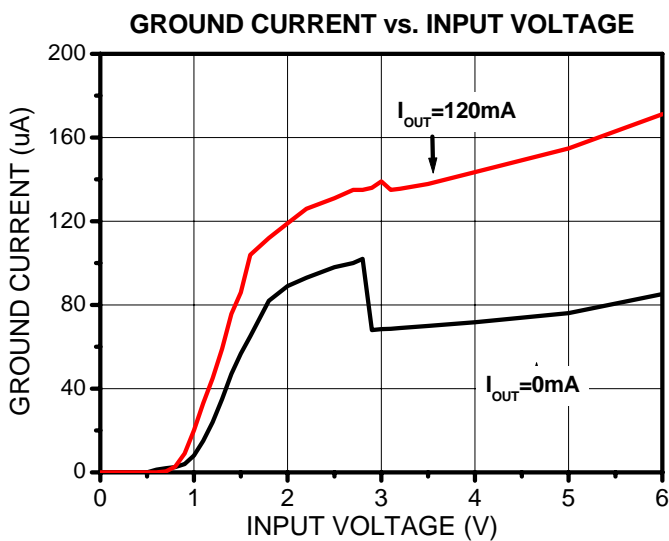
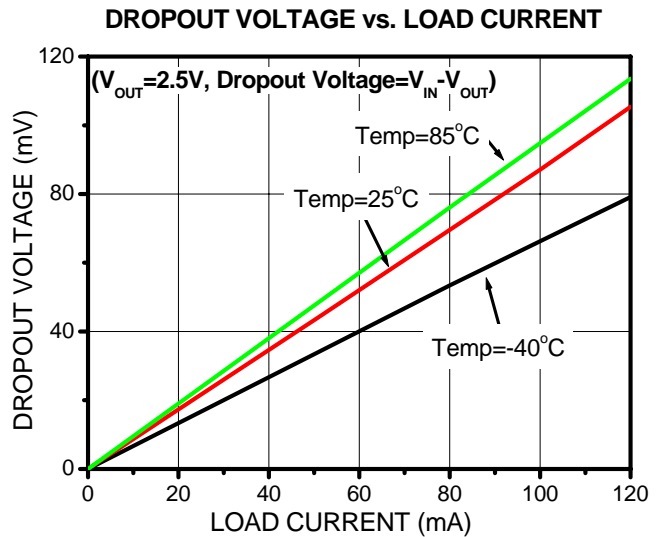
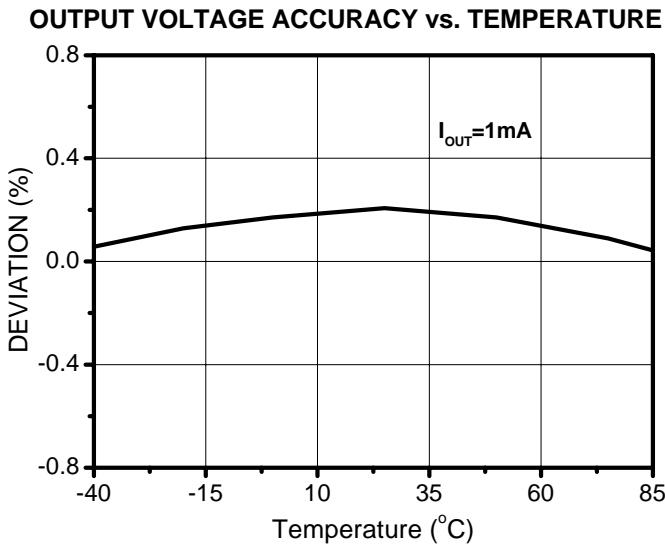
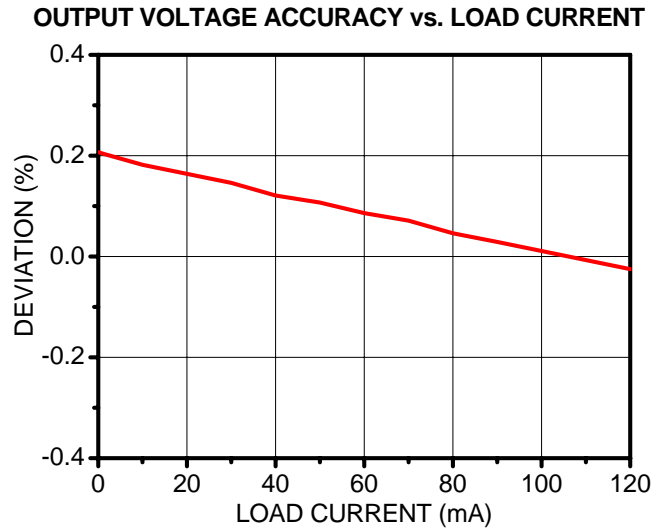
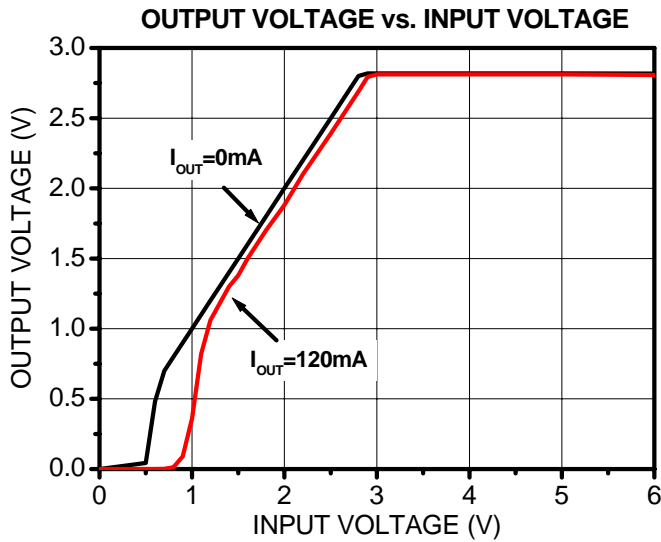

GROUND CURRENT vs. TEMPERATURE

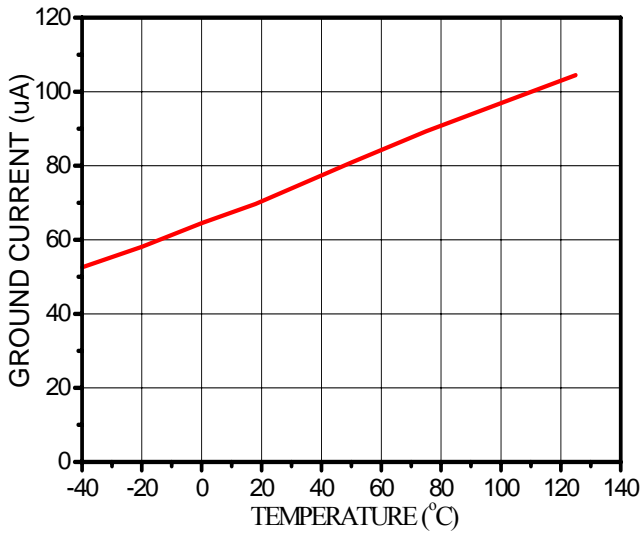

PSRR

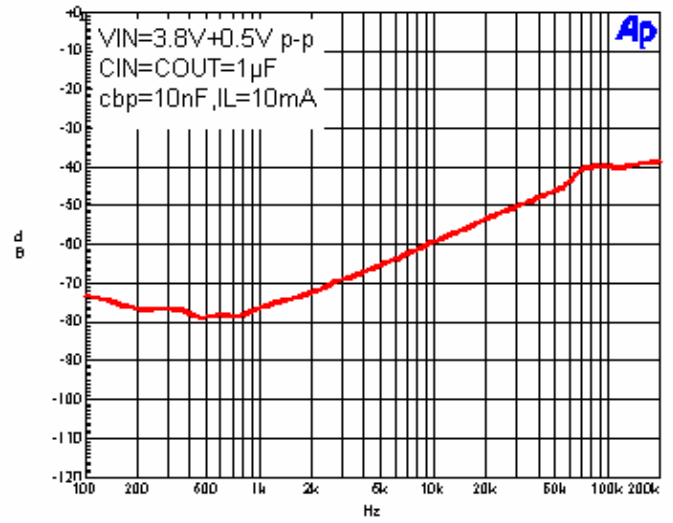

Noise

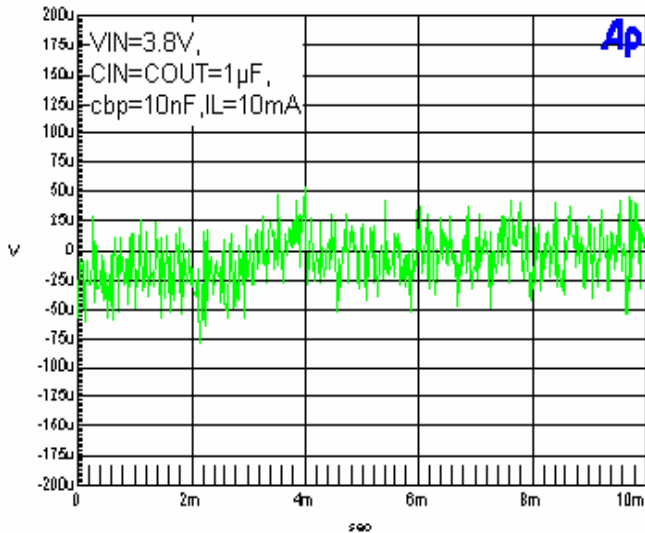

LOAD TRANSIENT RESPONSE

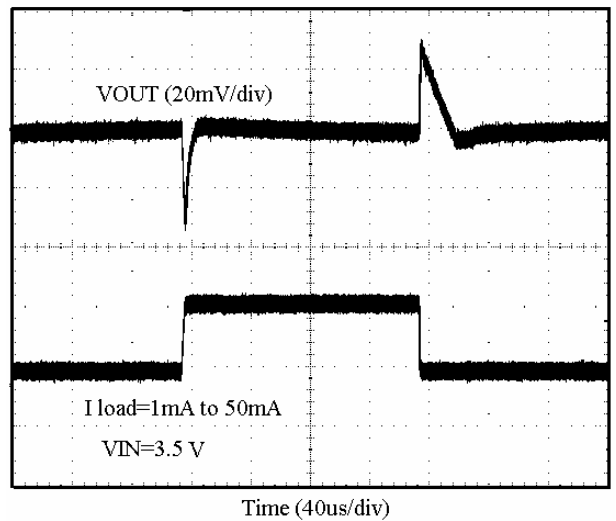

LOAD TRANSIENT RESPONSE NEAR DROPOUT

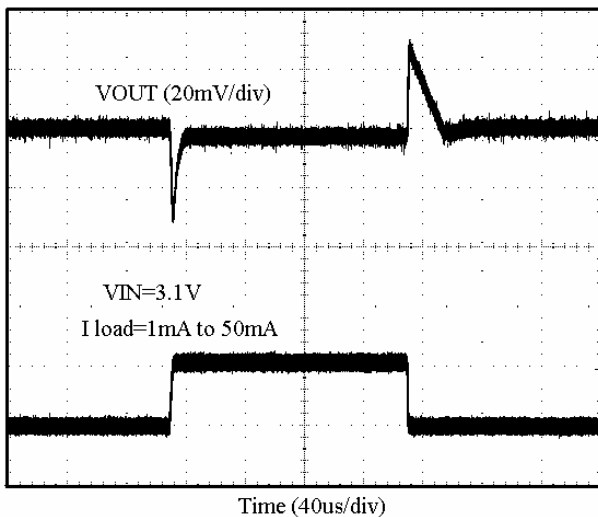

LOAD TRANSIENT RESPONSE

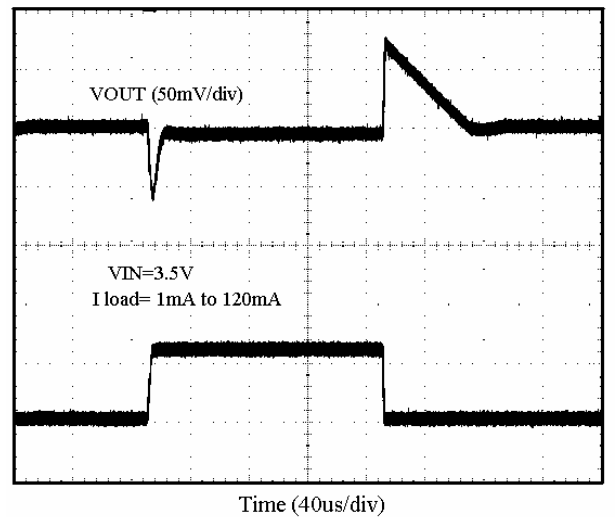

LINE TRANSIENT RESPONSE

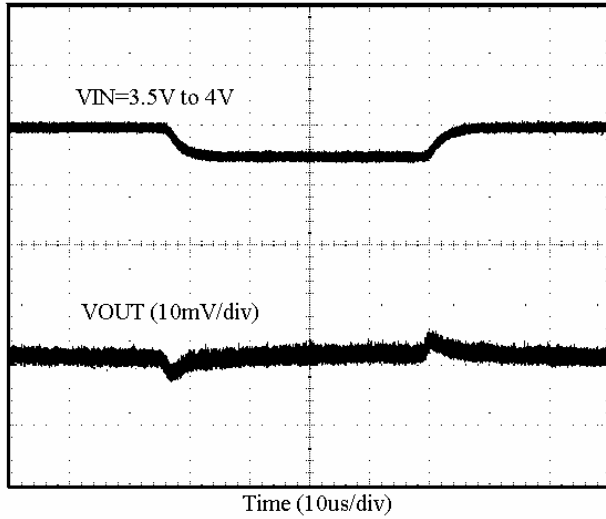

EXITING SHUTDOWN WAVEFORM

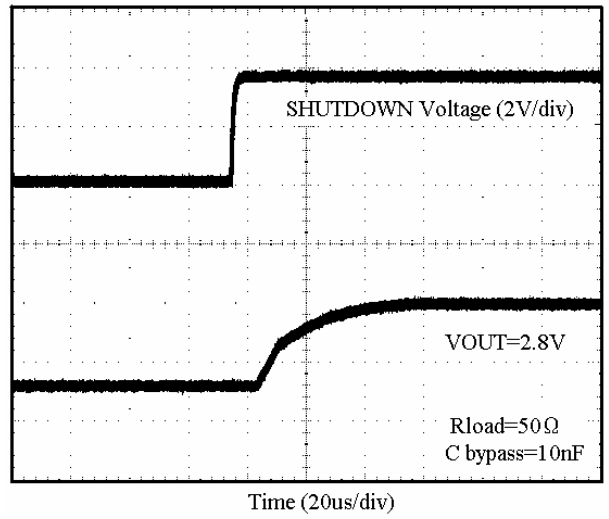

ENTERING SHUTDOWN WAVEFORM

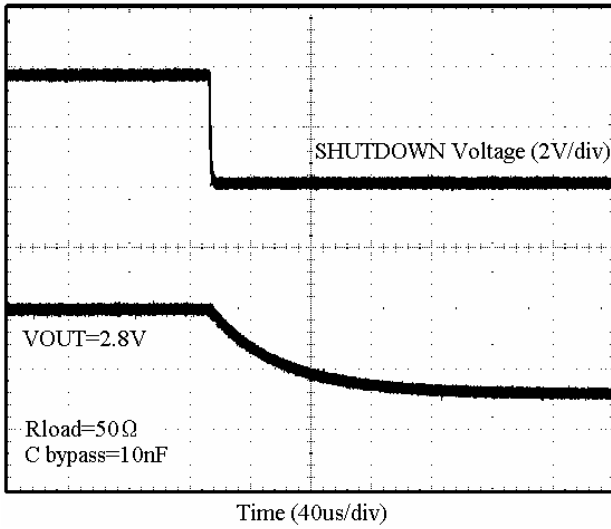

SHUTDOWN RESPONSE WAVEFORM
(CBP=100nF)

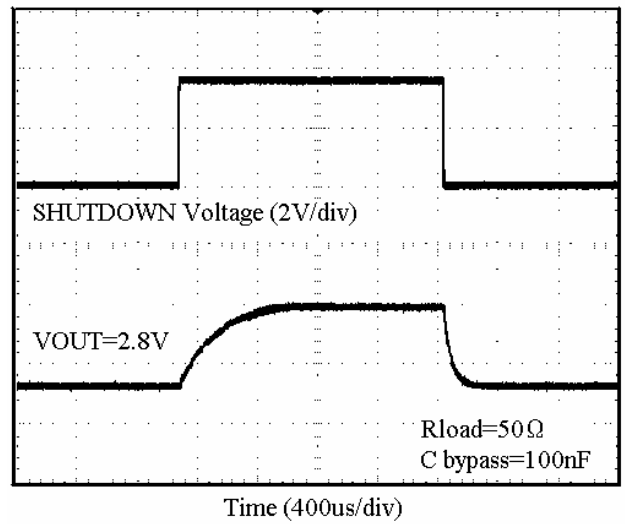

Application Note

External Capacitors

Like any low-dropout regulator, the EUP7915 requires external capacitors for regulator stability. The EUP7915 is specifically designed for portable applications requiring minimum board space and smallest components. These capacitors must be correctly selected for good performance.

Input Capacitor

An input capacitance of 1 μ F is required between the EUP7915 input pin and ground (the amount of the capacitance may be increased without limit).

This capacitor must be located a distance of not more than 1cm from the input pin and returned to a clean analog ground. Any good quality ceramic, tantalum, or film capacitor may be used at the input.

If a tantalum capacitor is used at the input, it must be guaranteed by the manufacturer to have a surge current rating sufficient for the application.

There are no requirements for the ESR on the input capacitor, but tolerance and temperature coefficient must be considered when selecting the capacitor to ensure the capacitance will be 1 μ F over the entire operating temperature range.

Output Capacitor

The EUP7915 is designed specifically to work with very small ceramic output capacitors. A ceramic capacitor (temperature characteristics X7R, X5R, Z5U, or Y5V) in 1 to 22 μ F range with 5m Ω to 500m Ω ESR range is suitable in the EUP7915 application circuit.

The output capacitor must meet the requirement for minimum amount of capacitance and also have an ESR (Equivalent Series Resistance) value which is within a stable range (5m Ω to 500m Ω)

No-Load Stability

The EUP7915 will remain stable and in regulation with no external load. This is specially important in CMOS RAM keep-alive applications.

Capacitor Characteristics

The EUP7915 is designed to work with ceramic capacitors on the output to take advantage of the benefits they offer: for capacitance values in the range of 1 μ F to 4.7 μ F range, ceramic capacitors are the smallest, least expensive and have the lowest ESR values (which makes them best for eliminating high frequency noise). The ESR of a typical 1 μ F ceramic capacitor is in the range of 20m Ω to 40m Ω , which easily meets the ESR requirement for stability by the EUP7915.

The ceramic capacitor's capacitance can vary with temperature. The capacitor type X7R, which operates over a temperature range of -55 $^{\circ}$ C to +125 $^{\circ}$ C, will only vary the capacitance to within \pm 15%. Most large value ceramic capacitors (\approx 2.2 μ F) are manufactured with Z5U or Y5V temperature characteristics. Their

capacitance can drop by more than 50% as the temperature goes from 25 $^{\circ}$ C to 85 $^{\circ}$ C. Therefore, X7R is recommended over Z5U and Y5V in applications where the ambient temperature will change significantly above or below 25 $^{\circ}$ C.

Noise Bypass Capacitor

Connecting a 0.01 μ F capacitor between the C_{BYPASS} pin and ground significantly reduces noise on the regulator output. This cap is connected directly to a high impedance node in the bandgap reference circuit. Any significant loading on this node will cause a change on the regulated output voltage. For this reason, DC leakage current through this pin must be kept as low as possible for best output voltage accuracy. The types of capacitors best suited for the noise bypass capacitor are ceramic and film.

Unlike many other LDO's, addition of a noise reduction capacitor does not effect the load transient response of the device.

Adjustable Operation

The adjustable version of the EUP7915 has an output voltage range of 1.2V to 5.3V. The output voltage of the EUP7915 adjustable regulator is programmed using an external resistor divider as shown in Figure 5. The output voltage is calculated using:

$$V_O = V_{ref} \times \left(1 + \frac{R_1}{R_2}\right)$$

Where:

V_{ref}= 1.2V typ. (the internal reference voltage)

Utilize the following equation for adjusting the output to a particular voltage:

$$R_1 = R_2 \left[\frac{V_O}{1.2V} - 1 \right]$$

Choose R₂=50k to optimize accuracy, power supply rejection, noise and power consumption.

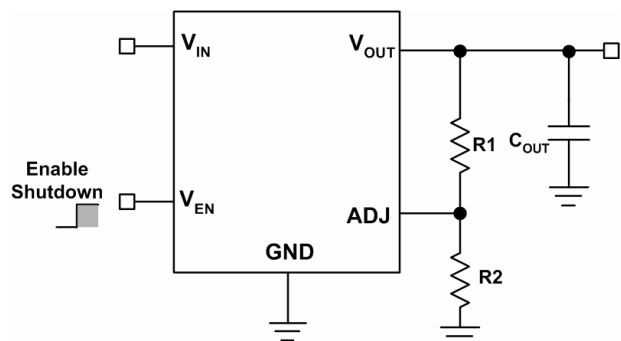

$$V_{OUT} = 1.2V(1 + R1/R2)$$

Figure5. Adjustable Regulator with Resistors

On/Off Input Operation

The EUP7915 is turned off by pulling the V_{EN} pin low, and turned on by pulling it high. If this feature is not used, the V_{EN} pin should be tied to V_{IN} to keep the regulator output on at all time. To assure proper operation, the signal source used to drive the V_{EN} input must be able to swing above and below the specified turn-on/off voltage thresholds listed in the Electrical Characteristics section under V_{IL} and V_{IH} .

Fast Start up

The EUP7915 output starts up after V_{ref} voltage reaches its final value (1.2V nominal). The start-up time is determined by the time constant of the bypass capacitor. The smaller the capacitor value, the shorter the start-up time, but less noise gets reduced. As a result, start-up time and noise reduction need to be taken into design consideration when choosing the value of the bypass capacitor.

Packaging Information

SOT23-5

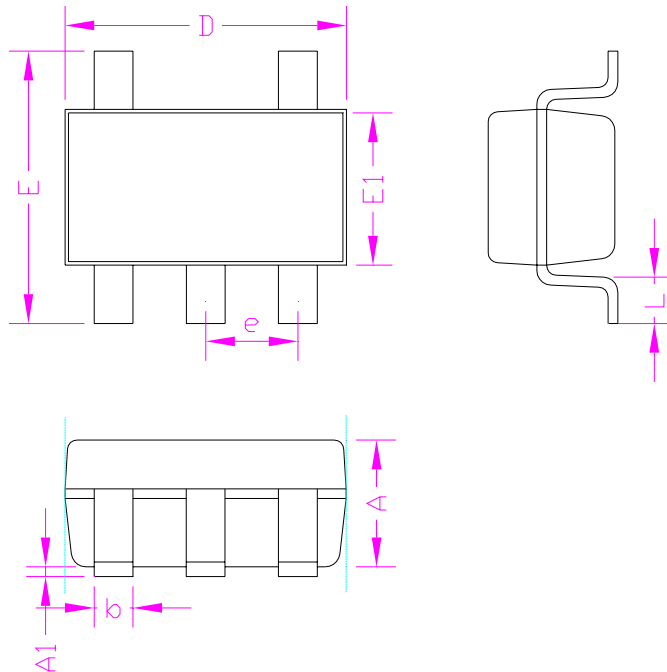

SYMBOLS	MILLIMETERS		INCHES	
	MIN.	MAX.	MIN.	MAX.
A	-	1.30	-	0.052
A1	0.00	0.15	0.000	0.006
D	2.90		0.114	
E1	1.60		0.063	
E	2.60	3.00	0.102	0.118
L	0.30	0.60	0.012	0.024
b	0.30	0.50	0.012	0.020
e	0.95		0.037	