

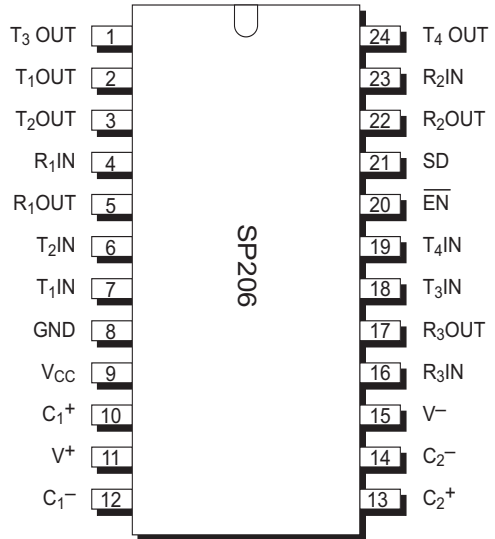

+5V RS-232 Serial Transceivers

FEATURES

- 0.1µF External Charge Pump Capacitors
- 120kbps Data Rate
- Standard SOIC and SSOP Packaging
- Multiple Drivers and Receivers
- Single 5V Supply Operation
- 1.0µA Shutdown Mode
- Tri-State Receiver Outputs
- Meets all RS-232F and V.28 Specifications
- Improved Driver Output Capacity for Mouse Applications
- +/-10kV ESD Protection*



Now Available in Lead Free Packaging

Note: See page 4 for other pinouts

DESCRIPTION

The SP206, SP207, SP208 and SP211 are multi-channel RS-232 line transceivers in a variety of configurations to fit most communication needs. All models in this series feature low-power CMOS construction and Exar Patented (5,306,954) on-board charge pump circuitry to generate the +/-10V RS-232 voltage levels, using 0.1µF charge pump capacitors to save board space and reduce circuit cost. The SP206 and SP211 models feature a low-power shutdown mode which reduces power supply drain to 1 µA.

Model	Number of RS-232		No. of RX active in Shutdown	No. of External 0.1µF Capacitors	Shutdown	WakeUp	TTL Tri-State
	Drivers	Receivers					
SP206	4	3	0	4	Yes	No	Yes
SP207	5	3	0	4	No	No	No
SP208	4	4	0	4	No	No	No
SP211	4	5	0	4	Yes	No	Yes

Table 1. Mode Selection Table

* All Driver Outputs and Receiver Input characterized per MIL-STD-883C Method 3015.
 Exar Corporation 18120 Kato Road, Fremont CA, 94538 • (415) 670-7000 • Fax: (510) 668-7717 • www.exar.com SP206, 207, 208, 211 101_060111

ABSOLUTE MAXIMUM RATINGS

These are stress ratings only and functional operation of the device at these ratings or any other above those indicated in the operation sections of the specifications below are not implied. Exposure to absolute maximum ratings conditions for extended periods of time may affect reliability.

Supply Voltage (V_{CC})..... + 6V
 $V+$ ($V_{CC}-0.3V$) to +13.2V
 $V-$ -13.2V
 Input Voltages
 T_{in} -0.3V to ($V_{CC} + 0.3V$)
 R_{in} +/-20V
 Output Voltages
 T_{out} ($V+$, +0.3V) to ($V-$, -0.3V)
 R_{out} -0.3V to ($V_{CC} + 0.3V$)
 Short Circuit duration on T_{out} Continuous

Package Power Dissipation:

24-pin SSOP
 (derate 11.2mW/°C above +70°C.....900mW
 24-pin WSOIC
 (derate 12.5mW/°C above +70°C.....1000mW
 28-pin SSOP
 (derate 11.2mW/°C above +70°C.....900mW
 28-pin WSOIC
 (derate 12.7mW/°C above +70°C.....1000mW

Storage Temperature.....-65°C to +150°C
 Lead Temperature (soldering, 10s)..... +300°C

ELECTRICAL CHARACTERISTICS

$V_{CC} = 5V$, $C1$ to $C4 = 0.1\mu F$, T_{MIN} to T_{MAX} , unless otherwise noted.

PARAMETER	TEST CONDITIONS	MIN	TYP	MAX	UNIT
TTL INPUT					
Logic Threshold LOW, V_{IL}	$T_{IN}, \overline{EN}, SD$			0.8	Volts
Logic Threshold HIGH, V_{IH}	$T_{IN}, \overline{EN}, SD$	2.0			Volts
Logic Pull-Up Current	$T_{IN} = 0V$		15	200	μA
Maximum Data Rate	$C_L = 2500pF, R_L = 3k\Omega$	120			kbps
TTL OUTPUT					
Output Voltage LOW, V_{OL}	$I_{OUT} = 3.2mA; V_{CC} = +5V$			0.4	Volts
Output Voltage HIGH, V_{OH}	$I_{OUT} = -1.0mA$	3.5			Volts
Leakage Current	$\overline{EN} = V_{CC}, 0V \leq V_{OUT} \leq V_{CC}$ $T_A = 25^\circ C$		0.05	+/-10	μA
RS-232 OUTPUT					
Output Voltage Swing	All Transmitter outputs loaded with 3k ohms to GND	+/-5.0	+/-7		Volts
Output Resistance	$V_{CC} = 0V, V_{out} = +/-2V$	300			Ohms
Output Short Circuit Current	Infinite Duration		+/-25		mA
RS-232 INPUT					
Voltage Range		-15		+15	Volts
Voltage Threshold LOW	$V_{CC} = 5V, T_A = 25^\circ C$	0.8	1.2		Volts
Voltage Threshold HIGH	$V_{CC} = 5V, T_A = 25^\circ C$		1.7	2.4	Volts
Hysteresis	$V_{CC} = 5V$	0.2	0.5	1.0	Volts
Resistance	$T_A = 25^\circ C, -15V \leq V_{IN} \leq +15V$	3	5	7	k Ω

ELECTRICAL CHARACTERISTICS

V_{CC} = 5.0V, C₁ to C₄ = 0.1μF, T_{MIN} to T_{MAX}, unless otherwise noted.

Parameter	TEST CONDITIONS	MIN	TYP	MAX	Unit
DYNAMIC CHARACTERISTICS					
Receiver Propagation Delay	RS-232 to TTL,		1.5		μs
Instantaneous Slew Rate	C _L = 50pF, R _L = 3-7kΩ, T _A =25°C			30	V/ μs
Transition Region Slew Rate	C _L = 2500pF, R _L = 3kΩ; Measured from +3V to -3V or -3V to +3V		5		V/ μs
Output Enable Time			400		ns
Output Disable Time			250		ns
POWER REQUIREMENTS					
V _{CC} (SP207)		4.75	5.00	5.25	Volts
V _{CC} (SP206, SP208 and SP211)		4.50	5.00	5.5	Volts
V _{CC} Power Supply Current	No Load, V _{CC} = +/-10%, T _A =25°C		4	10	mA
V _{CC} Power Supply Current, Loaded	All Transmitters R _L = 3kΩ, T _A =25°C		20		mA
Shutdown Supply Current	T _A =25°C		1	10	μA
ENVIRONMENTAL AND MECHANICAL					
Operating Temperature, Commercial, _C		0		+70	°C
Operating Temperature, Extended, _E		-40		+85	°C
Storage Temperature		-65		+150	°C
Package _A	Shrink (SSOP) small outline				
Package _T	Wide (SOIC) small outline				

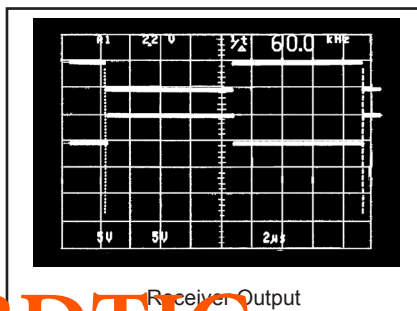
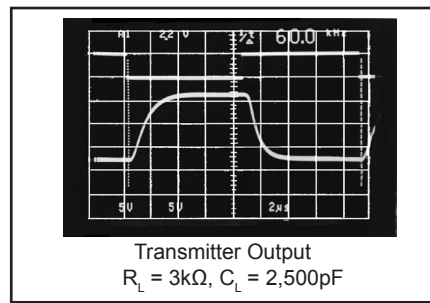
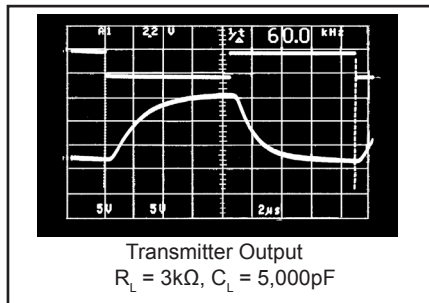

PACKAGE PINOUTS

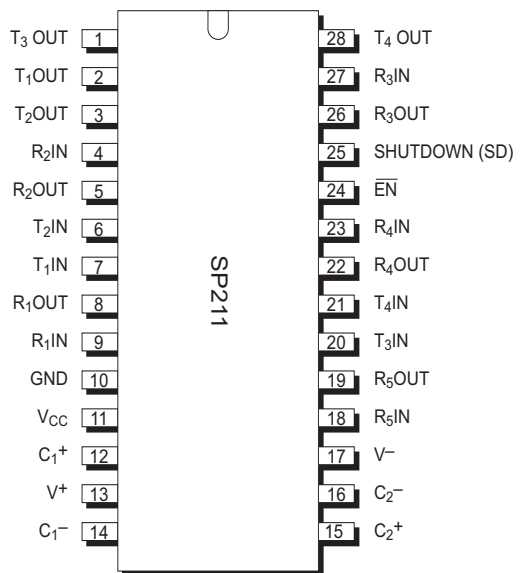
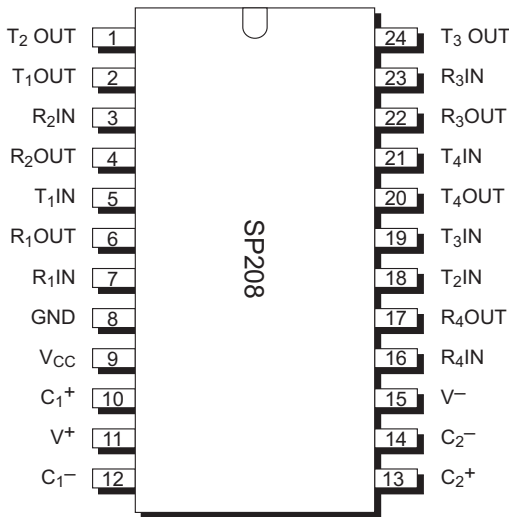
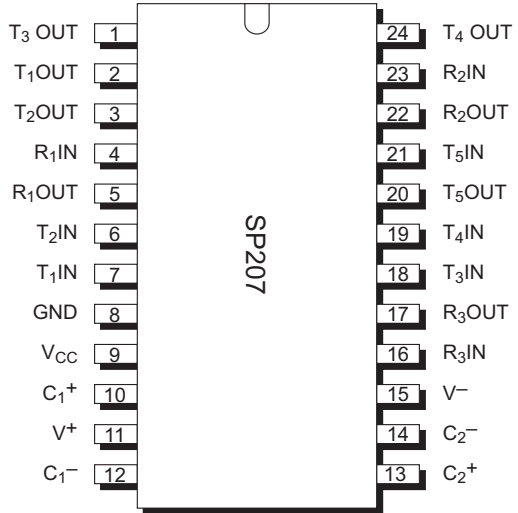
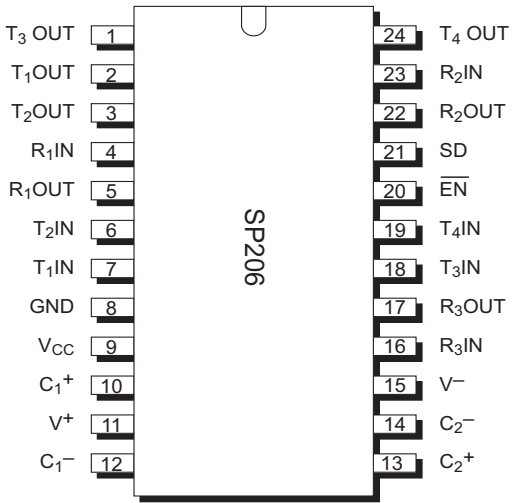

FEATURES

The SP206/207/208/211 multi-channel RS-232 line transceivers provide a variety of configurations to fit most communication needs, especially those applications where +/-12V is not available. All models in this series feature low-power CMOS construction and Exar's proprietary on-board charge pump circuitry to generate the +/-10V RS-232 voltage levels. The ability to use 0.1 μ F charge pump capacitors saves board space and reduces circuit cost. Different models within the series provide different driver/receiver combinations to match any application requirement.

The SP206 and SP211 models feature a low-power shutdown mode that reduces power supply drain to 1 μ A.

The models in this series are available in 24-pin and 28-pin SO (wide) and SSOP (shrink) small outline packages. Devices can be specified for commercial (0°C to +70°C) or industrial/extended (-40°C to +85°C) operating temperatures.

THEORY OF OPERATION**CHARGE PUMP**

The charge pump is an Exar patented design and uses a unique approach compared to older less-efficient designs. The charge pump still requires four external capacitors, but uses a four phase voltage shifting technique to attain symmetrical +/-10V power supplies. Figure 1a shows the waveform found on the positive side of capacitor C2 and Figure 3b shows the negative side of capacitor C2. There is a free-running oscillator that controls the four phases of the voltage shifting. A description of each phase follows:

PHASE 1

Vss charge storage - During this phase of the clock cycle, the positive side of capacitors C1 and C2 are initially charged to +5V. C1+ is then switched to ground and the charge in C1- is transferred to C2-. Since C2+ is connected to +5V, the voltage potential across capacitor C2 is now 10V.

PHASE 2

Vss transfer: Phase two of the clock connects the negative terminal of C2 to the Vss storage capacitor and the positive terminal of C2 to ground, and transfers the generated -10V to C3. Simultaneously, the positive side of capacitor C1 is switched to +5V and the negative side is connected to ground.

PHASE 3

Vdd charge storage: The third phase of the clock is identical to the first phase. The charge transferred in C1 produces -5V in the negative terminal of C1, which is applied to the negative side of C2. Since C2+ is at +5V, the voltage potential across C2 is 10V.

PHASE 4

Vdd transfer: The fourth phase of the clock connects the negative terminal of C2 to ground, and transfers the generated 10V across C2 to C4, the Vdd storage capacitor. Again, simultaneously with this, the positive side of capacitor C1 is switched to +5V and the negative side is connected to ground, and the cycle begins again.

Since both V+ and V- are separately generated from Vcc; in a no-load condition V+ and V- will be symmetrical. Older charge pump approaches that generate V- from V+ will show a decrease in magnitude of V- compared to V+ due to the inherent inefficiencies in the design.

The clock rate for the charge pump typically operates at greater than 15kHz allowing the pump to run efficiently with small 0.1 μ F capacitors with a 16V breakdown voltage rating.

The SP206/207/208/211 devices are made up of three basic circuit blocks - 1) transmitter/driver, 2) receiver and 3) charge pump. Each model within the series incorporates variations of these circuit to achieve the desired configuration and performance.

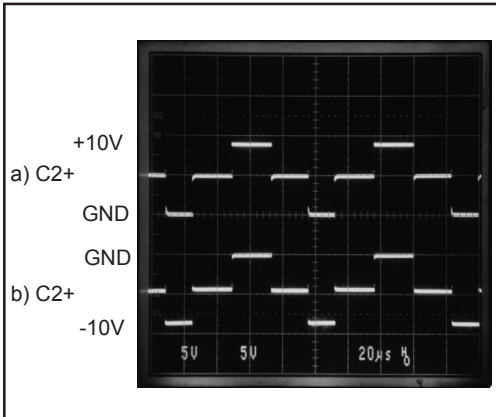

Figure 1. Charge Pump Waveforms

TRANSMITTER/DRIVER

The drivers are inverting transmitters, which accept either TTL or CMOS inputs and output the RS-232 output signals with an inverted sense relative to the input logic levels. Typically, the RS-232 output voltage swing is +/-9V with no load, and +/-5V minimum with full load. The transmitter outputs are protected against infinite short-circuits to ground without degradation in reliability. The drivers of the SP206 and SP211 can be tri-stated by using the SHUTDOWN function.

In the "power off" state, the output impedance will remain greater than 300 Ohms, again satisfying the RS-232 specifications. Should the input of the driver be left open, an internal 400kOhm pull-up resistor to V_{CC} forces the input high, thus committing the output to a low state. The slew rate of the transmitter output is internally limited to a maximum of $30V/\mu s$ in order to meet the EIA standards (EIA RS-232D 2,1,7, Paragraph 5). The transition of the loaded output from high to low also meets the monotonicity requirements of the standard.

RECEIVERS

The receivers convert RS-232 input signals to inverted TTL signals. Since the input is usually from a transmission line where long cable length and system interference can degrade the signal, the inputs have a typical hysteresis margin of 500mV. This ensures that the receiver is virtually immune to noisy transmission lines. Should an input be left unconnected, an internal 5kohm pull-down resistor to ground will commit the output of the receiver to a HIGH state.

SHUTDOWN MODE

The SP206 and SP211 feature a control input (SD) which will disable the device and reduce the power supply current to less than $10\mu A$, making the parts ideal for battery-powered systems. In the "shutdown" mode the receivers and transmitters will both be tri-stated. The $V+$ output of the charge pump will discharge to V_{CC} and the $V-$ output will discharge to ground.

ENABLE (\overline{EN})

The SP206 and SP211 feature an enable input which allows the receiver outputs to be either tri-stated or enabled. This can be especially useful when the receiver is tied directly to a microprocessor data bus. The enable pin is active high.

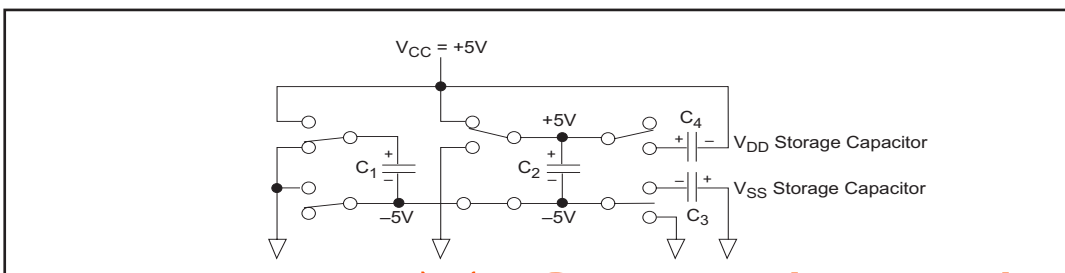

Figure 2. Charge pump - Phase 1

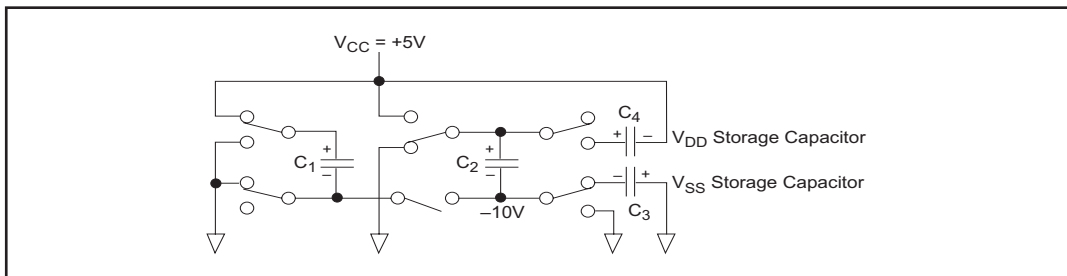

Figure 3, Charge pump - Phase 2

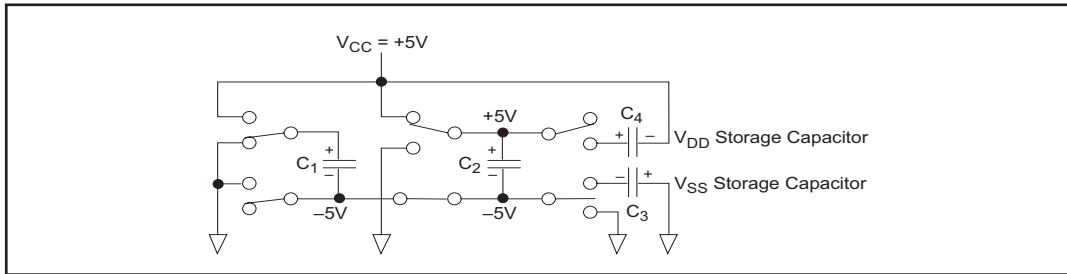

Figure 4, Charge pump - Phase 3

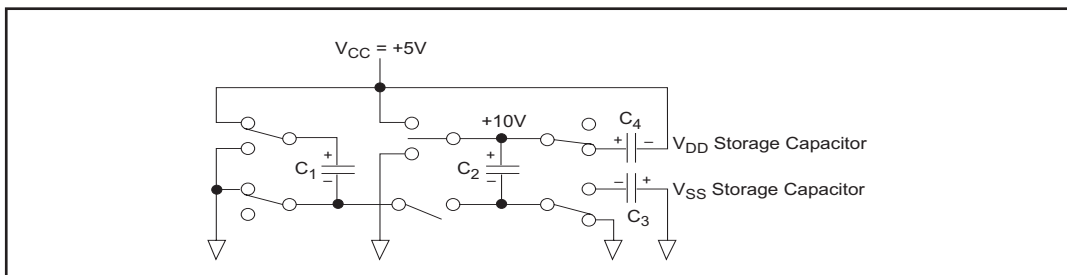

Figure 5, Charge pump - Phase 4

EIA STANDARDS

The Electronic Industry Association (EIA) developed several standards of data transmission which are revised and updated in order to meet the requirements of the industry. In data processing, there are two basic means of communicating between systems and components. The RS-232 standard was first introduced in 1962 and, since that time, has become an industry standard.

The RS-232 is a relatively slow data exchange protocol, with a maximum baud rate of only 20kbaud, which can be transmitted over a maximum copper wire cable length of 50 feet. The SP206 through SP211 series of data communications interface products have been designed to meet both the EIA protocol standards, and the needs of the industry.

+/-10kV ESD PROTECTION

The SP206/207/208/211 are equipped with Exar proprietary ESD protection circuitry on all RS-232 inputs and outputs. This series has been characterized using MIL-STD-883C Method 3015.7 Human Body Model. Each device in the family can withstand up to +/- 10kV of static discharge on all RS-232 inputs and outputs. All other pins of each device will maintain \geq +/-2kV of ESD protection.

TYPICAL APPLICATION CIRCUITS

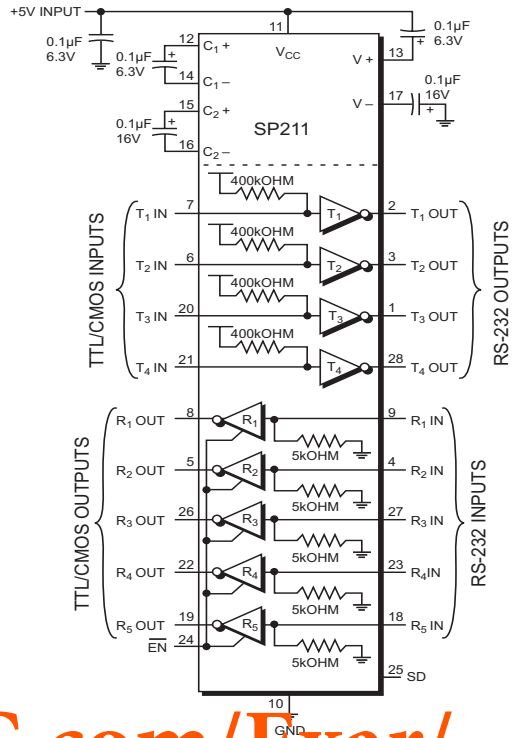
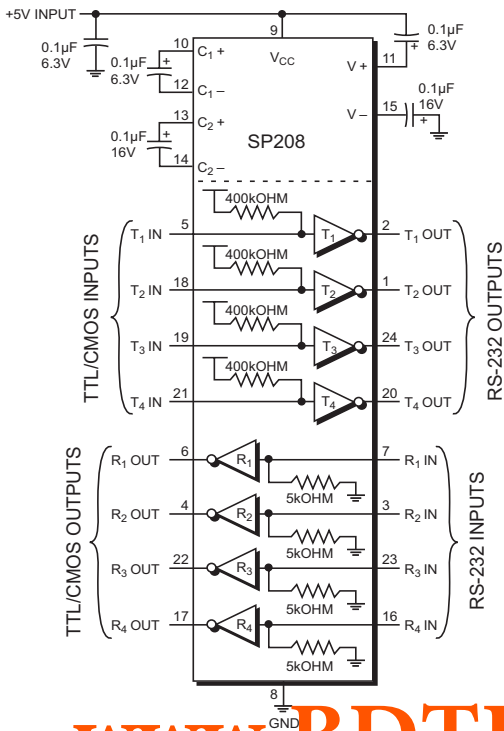
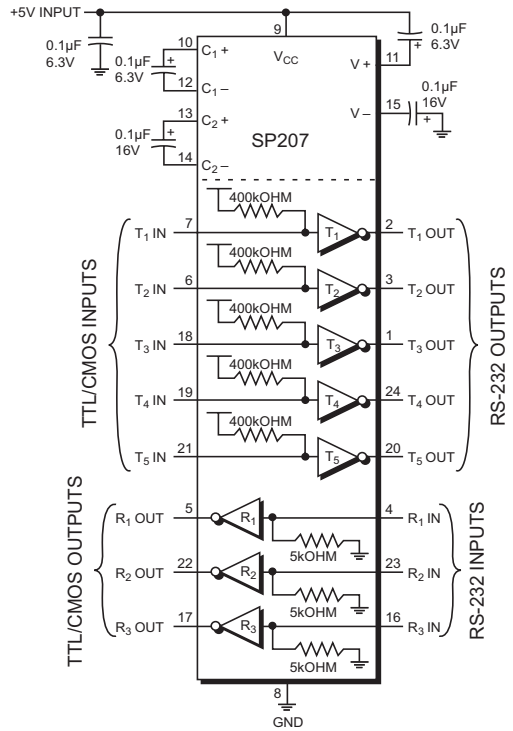
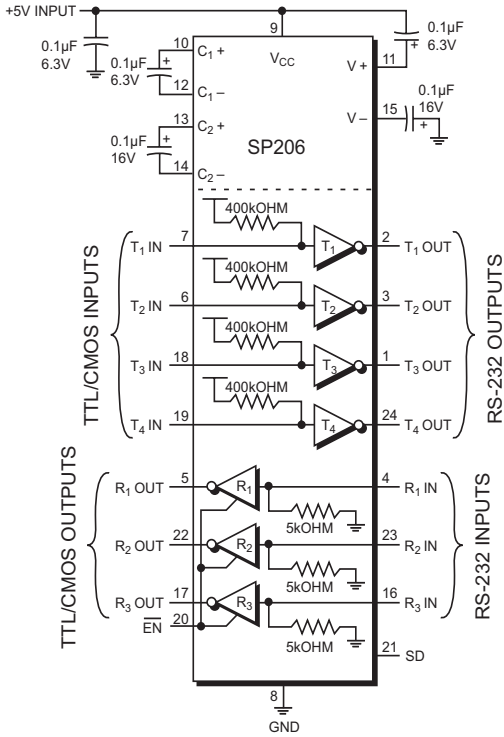

Top View

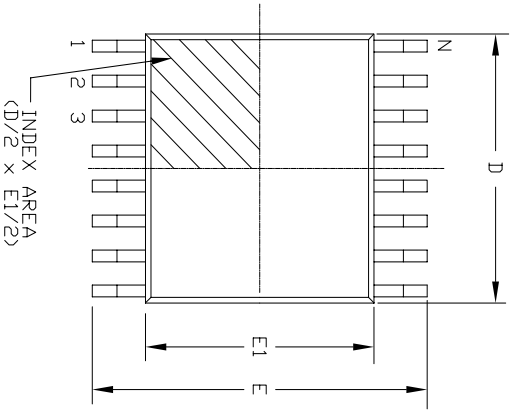

Side View

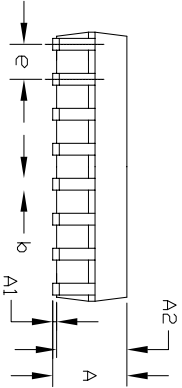

Front View

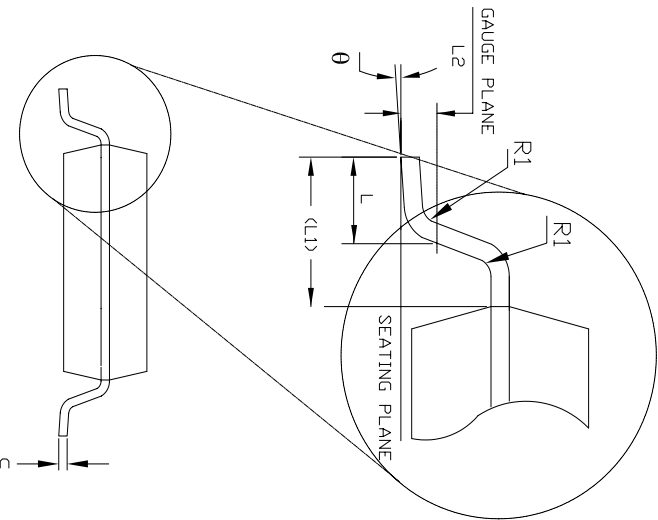

REVISION HISTORY			
REV.	DESCRIPTION	DATE	APP'D.
A	DRAWING ORIENTATION	04/24/06	JL
B	CHANGE DRAWING LOGO AND COMPANY NAME	11/28/07	JL

24 Pin SSOP JEDEC MO-150 Variation AG							
SYMBOLS	DIMENSIONS IN MM (Control Unit)			DIMENSIONS IN INCH (Reference Unit)			
	MIN	NOM	MAX	MIN	NOM	MAX	MAX
A	—	—	2.00	—	—	—	0.079
A1	0.05	—	—	0.002	—	—	—
A2	1.65	1.75	1.85	0.065	0.069	0.073	—
b	0.22	—	0.38	0.009	—	0.015	—
c	0.09	—	0.25	0.004	—	0.010	—
E	7.40	7.80	8.20	0.291	0.307	0.323	—
E1	5.00	5.30	5.60	0.197	0.209	0.220	—
e	0.65 BSC			0.026 BSC			
L	0.55	0.75	0.95	0.022	0.030	0.037	—
L1	1.25 REF			0.049 REF			
L2	0.25 BSC			0.010 BSC			
R1	0.09	—	—	0.004	—	—	—
theta	0°	4°	8°	0°	4°	8°	—
D	7.90	8.20	8.50	0.311	0.323	0.335	—
N	24			24			

		EXAR CORPORATION	
Packaging Approval:		24 PIN SSOP PACKAGE OUTLINE	
By: JL	Date: 11/28/07	Drawing No: B	24-PIN SSOP
		Revision: 1	Sheet: 1 OF 1

REVISION HISTORY				
REV.	DESCRIPTION	DATE	APP'D	
A	DRAWING ORIGINATOR	04/24/06	JL	
B	CHANGE DRAWING LOGO AND COMPANY NAME	11/28/07	JL	

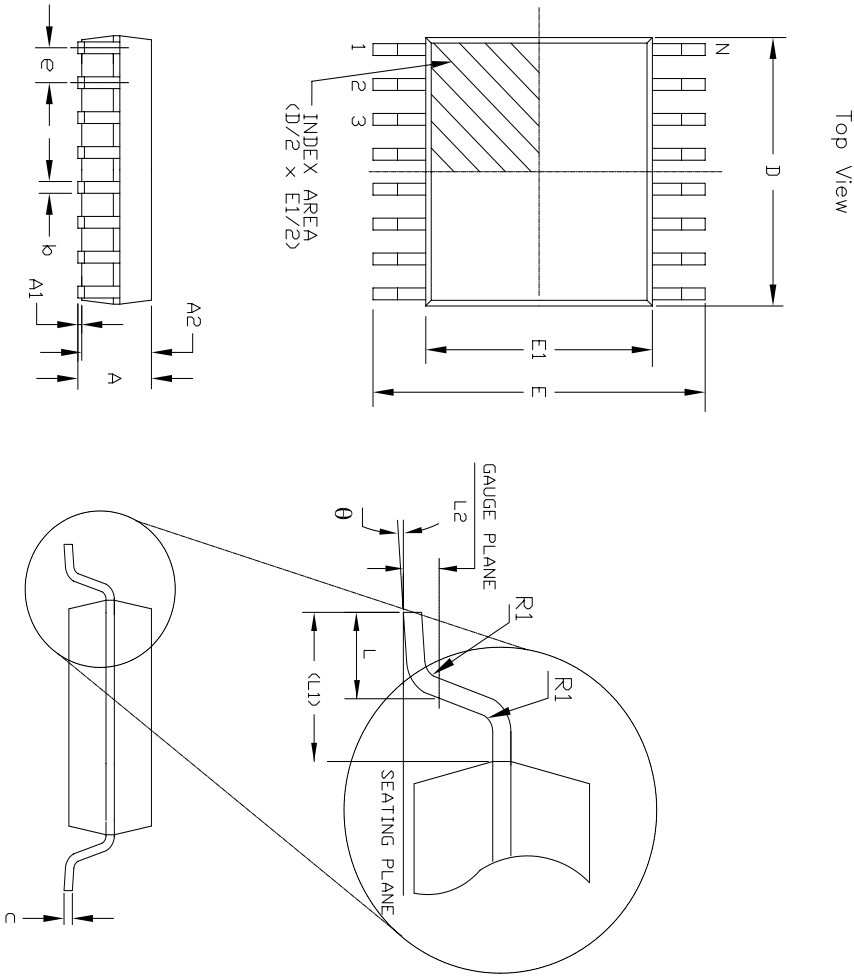

28 Pin SSOP JEDEC MO-150 Variation AH						
SYMBOLS	DIMENSIONS IN MM (Control Unit)			DIMENSIONS IN INCH (Reference Unit)		
	MIN	NOM	MAX	MIN	NOM	MAX
A	0.05	—	2.00	—	—	0.079
A1	0.05	—	0.002	—	—	—
A2	1.65	1.75	1.85	0.065	0.069	0.073
b	0.22	—	0.38	0.009	—	0.015
c	0.09	—	0.25	0.004	—	0.010
E	7.40	7.80	8.20	0.291	0.307	0.323
E1	5.00	5.30	5.60	0.197	0.209	0.220
e	0.65 BSC			0.026 BSC		
L	0.55	0.75	0.95	0.022	0.030	0.037
L1	1.25 REF			0.049 REF		
L2	0.25 BSC			0.010 BSC		
R1	0.09	—	—	0.004	—	—
θ	0°	4°	8°	0°	4°	8°
D	9.90	10.20	10.50	0.390	0.402	0.413
N	28			28		

		EXAR CORPORATION Packaging Approval:		Drawing No.: 28-PIN SSOP OUTLINE	
				Revision: B	
By: JL	Date: 11/28/07	Drawing No.: 28-PIN SSOP		Sheet: 1 OF 1	

REVISION HISTORY			
REV.	DESCRIPTION	DATE	APP'D
A	DRAWING ORIGINATOR	04/24/06	JL
B	CHANGE DRAWING LOGO AND COMPANY NAME	11/29/07	JL

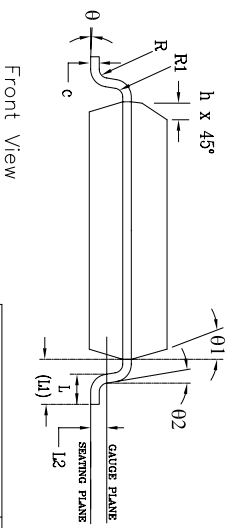
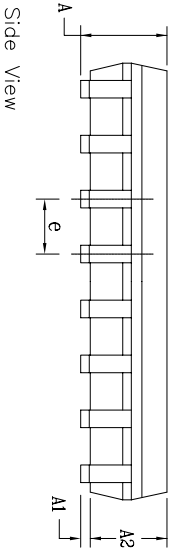
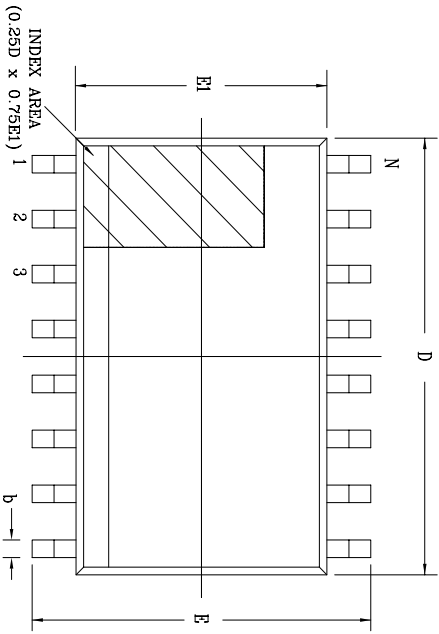

24 Pin SOICW		JEDEC MS-013		Variation AD		
SYMBOLS	DIMENSIONS IN MM (Control Unit)			DIMENSIONS IN INCH (Reference Unit)		
	MIN	NOM	MAX	MIN	NOM	MAX
A	2.35	—	2.65	0.093	—	0.104
A1	0.10	—	0.30	0.004	—	0.012
A2	2.05	—	2.55	0.081	—	0.100
b	0.31	—	0.51	0.012	—	0.020
c	0.20	—	0.33	0.008	—	0.013
E	10.30 BSC			0.406 BSC		
E1	7.50 BSC			0.295 BSC		
e	1.27 BSC			0.050 BSC		
h	0.25	—	0.75	0.010	—	0.030
L	0.40	—	1.27	0.016	—	0.050
L1	1.40 REF			0.055 REF		
L2	0.25 BSC			0.010 BSC		
R	0.07	—	—	0.003	—	—
R1	0.07	—	—	0.003	—	—
θ	0°	—	8°	0°	—	8°
θ1	5°	—	15°	5°	—	15°
θ2	0°	—	—	0°	—	—
D	15.40 BSC			0.606 BSC		
N	24			24		

		EXAR CORPORATION <small>EXAR CORPORATION</small>	
		24 PIN SOICW PACKAGE OUTLINE	
Packaging Approval:		Drawing No: 24-PIN SOICW	
By: JL	Date: 11/29/07	Revision: B	Sheet: 1 OF 1

REVISION HISTORY			
REV.	DESCRIPTION	DATE	APP'D
A	DRAWING ORIGINATOR	04/24/06	JL
B	CHANGE DRAWING LOGO AND COMPANY NAME	11/28/07	JL

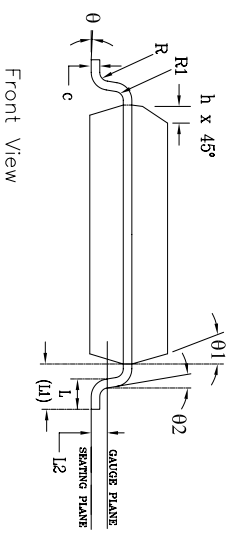
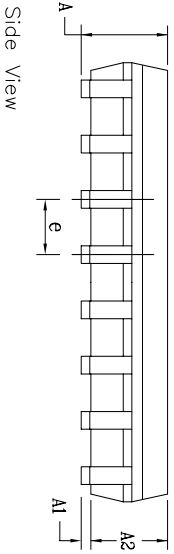
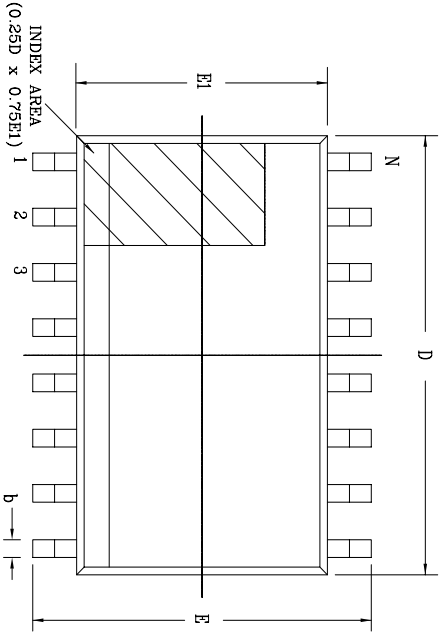

28 Pin SOICW		JEDEC MS-013 Variation AE			
SYMBOLS	DIMENSIONS IN MM		DIMENSIONS IN INCH		
	(Control Unit)		(Reference Unit)		
	MIN	NOM	MAX		
A	2.35	—	2.65	0.093	
A1	0.10	—	0.30	0.004	
A2	2.05	—	2.55	0.081	
b	0.31	—	0.51	0.012	
c	0.20	—	0.33	0.008	
E	—	10.30 BSC	—	0.406 BSC	
E1	—	7.50 BSC	—	0.295 BSC	
e	—	1.27 BSC	—	0.050 BSC	
h	0.25	—	0.75	0.010	
L	0.40	—	1.27	0.016	
L1	—	1.40 REF	—	0.055 REF	
L2	—	0.25 BSC	—	0.010 BSC	
R	0.07	—	0.003	—	
R1	0.07	—	0.003	—	
θ	0°	—	8°	—	
$\theta 1$	5°	—	15°	—	
$\theta 2$	0°	—	0°	—	
D	—	17.90 BSC	—	0.705 BSC	
N	—	28	—	28	

		EXAR CORPORATION	
		28 PIN SOICW PACKAGE OUTLINE	
Packaging Approval:	By: JL	Date: 11/28/07	Revision: B
Drawing No:	28-PIN SOICW		Sheet: 1 OF 1

Part number	Drivers	Receivers	Temperature range	Package Type
SP206CA-L	4	3	0 to +70°C	24 pin SSOP
SP206CA-L/TR	4	3	0 to +70°C	24 pin SSOP
SP206CT-L	4	3	0 to +70°C	24 pin WSOIC
SP206CT-L/TR	4	3	0 to +70°C	24 pin WSOIC
SP206EA-L	4	3	-40 to +85°C	24 pin SSOP
SP206EA-L/TR	4	3	-40 to +85°C	24 pin SSOP
SP206ET-L	4	3	-40 to +85°C	24 pin WSOIC
SP206ET-L/TR	4	3	-40 to +85°C	24 pin WSOIC
SP207CT-L	5	3	0 to +70°C	24 pin WSOIC
SP207CT-L/TR	5	3	0 to +70°C	24 pin WSOIC
SP207ET-L	5	3	-40 to +85°C	24 pin WSOIC
SP207ET-L/TR	5	3	-40 to +85°C	24 pin WSOIC
SP208CA-L	4	4	0 to +70°C	24 pin SSOP
SP208CA-L/TR	4	4	0 to +70°C	24 pin SSOP
SP208CT-L	4	4	0 to +70°C	24 pin WSOIC
SP208CT-L/TR	4	4	0 to +70°C	24 pin WSOIC
SP208EA-L	4	4	-40 to +85°C	24 pin SSOP
SP208EA-L/TR	4	4	-40 to +85°C	24 pin SSOP
SP208ET-L	4	4	-40 to +85°C	24 pin WSOIC
SP208ET-L/TR	4	4	-40 to +85°C	24 pin WSOIC
SP211CA-L	4	5	0 to +70°C	28 pin SSOP
SP211CA-L/TR	4	5	0 to +70°C	28 pin SSOP
SP211CT-L	4	5	0 to +70°C	28 pin WSOIC
SP211CT-L/TR	4	5	0 to +70°C	28 pin WSOIC
SP211EA-L	4	5	-40 to +85°C	28 pin SSOP
SP211EA-L/TR	4	5	-40 to +85°C	28 pin SSOP
SP211ET-L	4	5	-40 to +85°C	28 pin WSOIC
SP211ET-L/TR	4	5	-40 to +85°C	28 pin WSOIC

REVISION HISTORY		
Date	Revision	Description
5-26-05	Rev B	Original SP200/204/206/207/208/211/213 Sipex Data sheet
7-16-10	1.0.0	Change revision to 1.0.0 and convert to Exar format. Remove EOL part numbers and associated verbiage. Update ordering information.
June 2011	1.0.1	SP207CA-L and SP207EA-L options removed per PDN 110510-01

Notice

EXAR Corporation reserves the right to make changes to any products contained in this publication in order to improve design, performance or reliability. EXAR Corporation assumes no representation that the circuits are free of patent infringement. Charts and schedules contained herein are only for illustration purposes and may vary depending upon a user's specific application. While the information in this publication has been carefully checked; no responsibility, however, is assumed for inaccuracies.

EXAR Corporation does not recommend the use of any of its products in life support applications where the failure or malfunction of the product can reasonably be expected to cause failure of the life support system or to significantly affect its safety or effectiveness. Products are not authorized for use in such applications unless EXAR Corporation receives, in writing, assurances to its satisfaction that: (a) the risk of injury or damage has been minimized ; (b) the user assumes all such risks; (c) potential liability of EXAR Corporation is adequately protected under the circumstances.

Copyright 2011 EXAR Corporation

Datasheet June 2011

Send your Serial Transceiver technical inquiry with technical details to: serialtechsupport@exar.com

Reproduction, in part or whole, without the prior written consent of EXAR Corporation is prohibited.

www.BDTIC.com/Exar/