



SP3490/SP3491

+3.3V Low Power Full Duplex RS-485 Transceivers with 10Mbps Data Rate

- Full Duplex RS-485 and RS-422 Transceivers
- Operates from a single +3.3V supply
- Interoperable with +5.0V logic
- Driver/Receiver Tri-state Enable Lines (**SP3491**)
- -7V to +12V Common-Mode Input Voltage Range
- $\pm 200\text{mV}$ Receiver Input Sensitivity
- Allows up to 32 transceivers on the serial bus
- Compatibility with LTC490 and SN75179 (**SP3490**)
- Compatibility with LTC491 and SN75180 (**SP3491**)



Now Available in Lead Free Packaging

DESCRIPTION

The **SP3490** and the **SP3491** are +3.3V low power full duplex transceivers that meet the specifications of the RS-485 and RS-422 serial protocols. These devices are pin-to-pin compatible with the **Sipex** SP490 and SP491 devices as well as popular industry standards. The **SP3490** and the **SP3491** feature **Sipex's** BiCMOS process, allowing low power operation without sacrificing performance. The **SP3490** and **SP3491** meet the electrical specifications of RS-485 and RS-422 serial protocols up to 10Mbps under load. The **SP3491** is identical to the **SP3490** with the addition of driver and receiver tri-state enable lines.

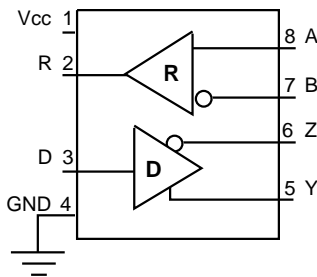

SP3490

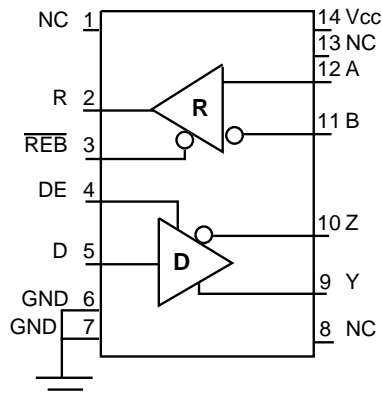

SP3491

ABSOLUTE MAXIMUM RATINGS

These are stress ratings only and functional operation of the device at these ratings or any other above those indicated in the operation sections of the specifications below is not implied. Exposure to absolute maximum rating conditions for extended periods of time may affect reliability.

V _{CC}	+6.0V
Input Voltages	
Drivers	-0.3V to +6.0V
Receivers	±14V
Output Voltages	
Drivers	±14V
Receivers	-0.3V to +6.0V
Storage Temperature	-65°C to +150°C
Power Dissipation per Package	
8-pin NSOIC (derate 6.90mW/°C above +70°C)	600mW
8-pin PDIP (derate 11.8mW/°C above +70°C)	1000mW
14-pin NSOIC (derate 8.33mW/°C above +70°C)	700mW
14-pin PDIP (derate 14.3mW/°C above +70°C)	1200mW

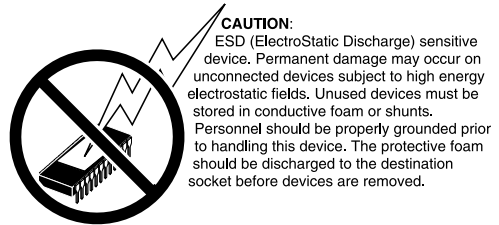

SPECIFICATIONS

T_{AMB} = T_{MIN} to T_{MAX} and V_{CC} = 3.3V ± 5% unless otherwise noted.

PARAMETERS	MIN.	TYP.	MAX.	UNITS	CONDITIONS
SP3490 DRIVER					
DC Characteristics					
Differential Output Voltage	GND		V _{CC}	Volts	Unloaded; R = ∞ Ω; <i>Figure 1</i>
Differential Output Voltage	2		V _{CC}	Volts	With Load; R = 50Ω; (RS-422); <i>Figure 1</i>
Differential Output Voltage Change in Magnitude of Driver	1.5		V _{CC}	Volts	With Load; R = 27Ω; (RS-485); <i>Figure 1</i>
Differential Output Voltage for Complimentary States			0.2	Volts	R = 27Ω or R = 50Ω; <i>Figure 1</i>
Driver Common-Mode Output Voltage			3	Volts	R = 27Ω or R = 50Ω; <i>Figure 1</i>
Input High Voltage	2.0			Volts	
Input Low Voltage			0.8	Volts	
Input Current			±10	µA	
Driver Short-Circuit Current			±250	mA	-7V ≤ V _O ≤ +12V
V _{OUT} = HIGH			±250	mA	-7V ≤ V _O ≤ +12V
V _{OUT} = LOW					
SP3490 DRIVER					
AC Characteristics					
Maximum Data Rate	10			Mbps	
Driver Input to Output, t _{PLH}	20	40	60	ns	R=27Ω, <i>Figures 2 and 8</i>
Driver Input to Output, t _{PHL}	20	40	60	ns	R=27Ω, <i>Figures 2 and 8</i>
Differential Driver Skew		2		ns	t _{PHL} (Y) - t _{PLH} (Y) , t _{PHL} (Z) - t _{PLH} (Z) , <i>Figures 2 and 8</i>
Driver Rise or Fall Time		5	20	ns	From 10% to 90%; <i>Figures 3 and 9</i>
SP3490 RECEIVER					
DC Characteristics					
Differential Input Threshold	0.2		+0.2	Volts	-7V ≤ V _{CM} ≤ 12V
Input Hysteresis		25		mV	V _{CM} = 0V
Output Voltage High	V _{CC} -0.4			Volts	I _O = -1.5mA, V _{ID} = +200mV
Output Voltage Low			0.4	Volts	I _O = +2.5mA, V _{ID} = -200mV
Input Resistance	12	15		kΩ	-7V ≤ V _{CM} ≤ 12V
Input Current (A, B); V _{IN} = 12V			1.0	mA	V _{IN} = 12V
Input Current (A, B); V _{IN} = -7V			-0.8	mA	V _{IN} = -7V
Short-Circuit Current			60	mA	0V ≤ V _O ≤ V _{CC}

SPECIFICATIONS (continued)

$T_{AMB} = T_{MIN}$ to T_{MAX} and $V_{CC} = 3.3V \pm 5\%$ unless otherwise noted.

PARAMETERS	MIN.	TYP.	MAX.	UNITS	CONDITIONS
SP3490 RECEIVER					
AC Characteristics					
Maximum Data Rate	10	70	120	Mbps	<i>Figures 6 and 11</i> $T_{AMB} = 25^{\circ}C, V_{CC} = 3.3V, \text{Figures 6 and 11}$
Receiver Input to Output, t_{PLH}	40	70	85	ns	
Receiver Input to Output, t_{PHL}	40	70	120	ns	<i>Figures 6 and 11</i> $T_{AMB} = 25^{\circ}C, V_{CC} = 3.3V, \text{Figures 6 and 11}$
Receiver Input to Output, t_{PHL}	40	70	85	ns	
Differential Receiver Skew		4		ns	$ t_{PHL}(A) - t_{PLH}(A) , t_{PHL}(B) - t_{PLH}(B) $, <i>Figures 6 and 11</i>
POWER REQUIREMENTS					
Supply Voltage	+3.0		+3.6	Volts	$DE = V_{CC}$ $DE = 0$
Supply Current		1000 800	2000 1500	μA	

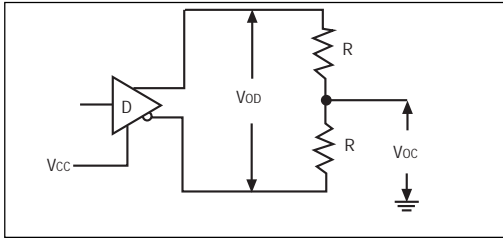

Figure 1. Driver DC Test Load Circuit

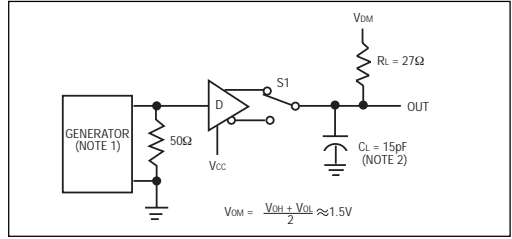

Figure 2. Driver Propagation Delay Test Circuit

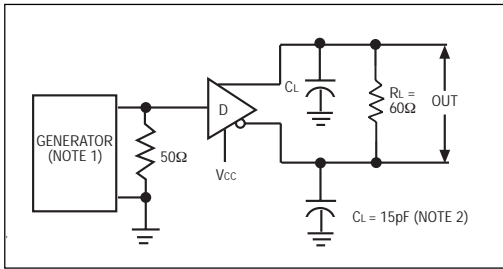

Figure 3. Driver Differential Output Delay and Transition Time Circuit

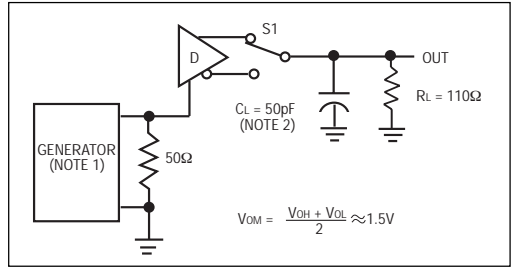

Figure 4. Driver Enable and Disable Timing Circuit, Output HIGH

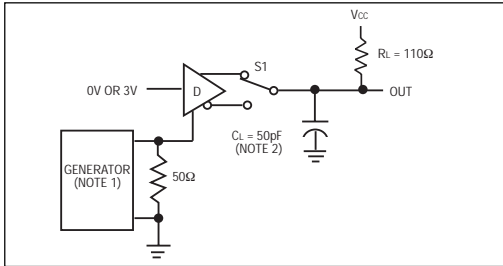

Figure 5. Driver Enable and Disable Timing Circuit, Output LOW

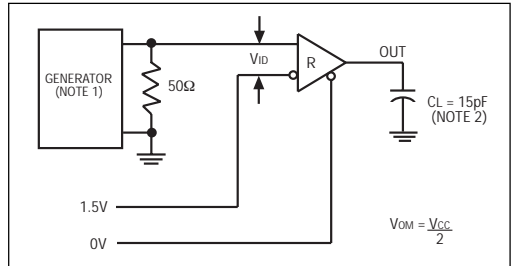

Figure 6. Receiver Propagation Delay Test Circuit

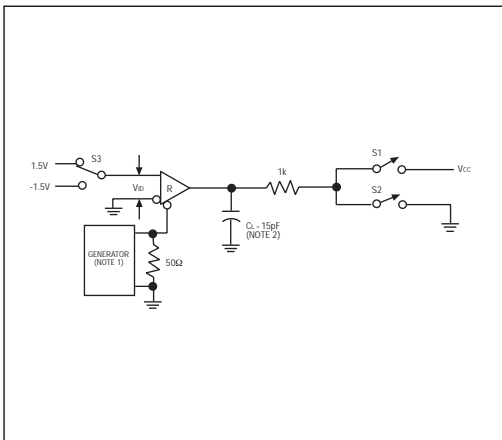

Figure 7. Receiver Enable and Disable Timing Circuit

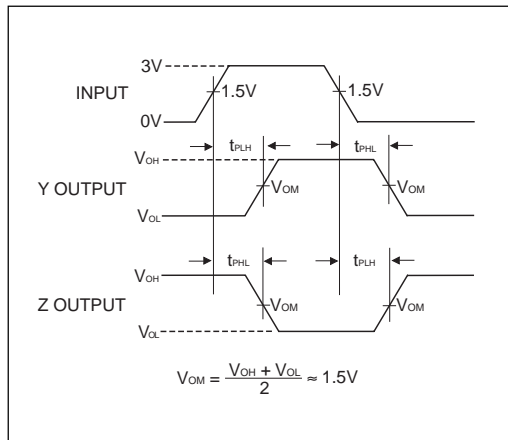

Figure 8. Driver Propagation Delay Waveforms

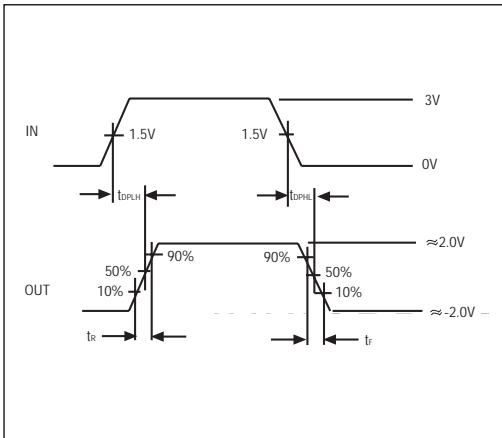

Figure 9. Driver Differential Output Delay and Transition Time Waveforms

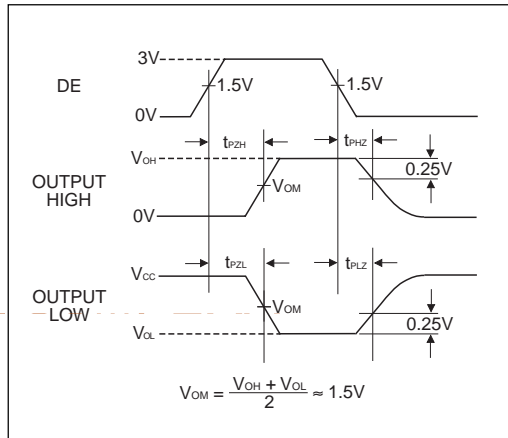

Figure 10. Driver Enable and Disable Timing Waveforms

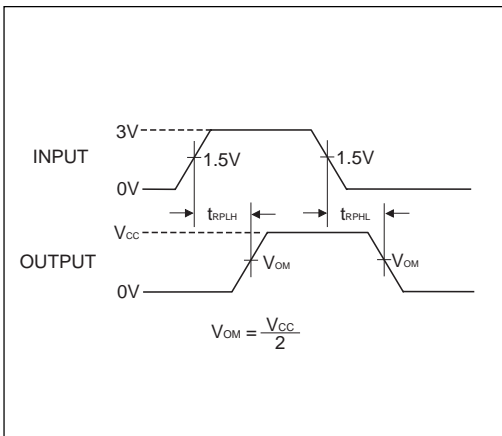

Figure 11. Receiver Propagation Delay Waveforms

SPECIFICATIONS

$T_{AMB} = T_{MIN}$ to T_{MAX} and $V_{CC} = +3.3V \pm 5\%$ unless otherwise noted.

PARAMETERS	MIN.	TYP.	MAX.	UNITS	CONDITIONS
SP3491 DRIVER					
DC Characteristics					
Differential Output Voltage	GND		V_{CC}	Volts	Unloaded; $R = \infty$; <i>Figure 1</i>
Differential Output Voltage	2		V_{CC}	Volts	With Load; $R = 50\Omega$; (RS-422); <i>Figure 1</i>
Differential Output Voltage Change in Magnitude of Driver Differential Output Voltage for Complimentary States	1.5		V_{CC}	Volts	With Load; $R = 27\Omega$; (RS-485); <i>Figure 1</i>
Driver Common-Mode Output Voltage			0.2	Volts	$R = 27\Omega$ or $R = 50\Omega$; <i>Figure 1</i>
Input HIGH Voltage	2.0		3	Volts	$R = 27\Omega$ or $R = 50\Omega$; <i>Figure 1</i>
Input LOW Voltage			0.8	Volts	Applies to D, REB, DE
Input Current			± 10	μA	Applies to D, REB, DE
Driver Short-Circuit Current			± 250	mA	$-7V \leq V_O \leq +12V$
$V_{OUT} = HIGH$			± 250	mA	$-7V \leq V_O \leq +12V$
$V_{OUT} = LOW$					
SP3491 DRIVER					
AC Characteristics					
Maximum Data Rate	10			Mbps	
Driver Input to Output, t_{PLH}	20	40	60	ns	<i>Figures 2 and 8</i>
Driver Input to Output, t_{PHL}	20	40	60	ns	<i>Figures 2 and 8</i>
Differential Driver Skew		2		ns	$ t_{PHL}(Y) - t_{PLH}(Y) , t_{PHL}(Z) - t_{PLH}(Z) $, <i>Figures 2 and 8</i>
Driver Rise or Fall Time		5	20	ns	From 10% to 90%; <i>Figures 3 and 9</i>
Driver Enable to Output HIGH		52	120	ns	<i>Figures 4 and 10</i>
Driver Enable to Output LOW		60	120	ns	<i>Figures 5 and 10</i>
Driver Disable from LOW		40	120	ns	<i>Figures 5 and 10</i>
Driver Disable from HIGH		60	120	ns	<i>Figures 4 and 10</i>

NOTE 1: The input pulse is supplied by a generator with the following characteristics:

PRR=250KHz, 50% duty cycle, $t_r \leq 6.0ns$, $Z_0=50\Omega$.

NOTE 2: C_L includes probe and stray capacitance.

SPECIFICATIONS (continued)

$T_{AMB} = T_{MIN}$ to T_{MAX} and $V_{CC} = +3.3V \pm 5\%$ unless otherwise noted.

PARAMETERS	MIN.	TYP.	MAX.	UNITS	CONDITIONS
SP3491 RECEIVER					
DC Characteristics					
Differential Input Threshold	-0.2		+0.2	Volts	$-7V \leq V_{CM} \leq 12V$
Input Hysteresis		25		mV	$V_{CM} = 0V$
Output Voltage HIGH	$V_{CC}-0.4$			Volts	$I_O = -1.5mA, V_{ID} = +200mV$
Output Voltage LOW			0.4	Volts	$I_O = +2.5mA, V_{ID} = -200mV$
Three State (high impedance)					
Output Current			± 1	μA	$0V \leq V_O \leq V_{CC}; \overline{REB} = V_{CC}$
Input Resistance	12	15		k Ω	$-7V \leq V_{CM} \leq 12V$
Input Current (A, B); $V_{IN} = 12V$			1.0	mA	$DE = 0V, V_{CC} = 0V$ or $+3.6V, V_{IN} = 12V$
Input Current (A, B); $V_{IN} = -7V$			-0.8	mA	$DE = 0V, V_{CC} = 0V$ or $+3.6V, V_{IN} = -7V$
Short-Circuit Current			60	mA	$0V \leq V_O \leq V_{CC}$
SP3491 RECEIVER					
AC Characteristics					
Maximum Data Rate	10			Mbps	$\overline{REB} = 0V, DE = V_{CC}$
Receiver Input to Output, t_{PLH}	40	70	120	ns	Figures 6 & 11
			85	ns	$T_{AMB} = +25^\circ C, V_{CC} = +3.3V,$ Figures 6 and 11
Receiver Input to Output, t_{PHL}	40	70	120	ns	Figures 6 & 11
			85	ns	$T_{AMB} = +25^\circ C, V_{CC} = +3.3V,$ Figures 6 and 11
Differential Receiver Skew		4		ns	$ t_{PHL}(A) - t_{PLH}(A) , t_{PHL}(B) - t_{PLH}(B) ,$ Figures 6 & 11
Receiver Enable to Output LOW		65	150	ns	Figures 7 and 12; S_1 closed, S_2 open
Receiver Enable to Output HIGH		65	150	ns	Figures 7 and 12; S_2 closed, S_1 open
Receiver Disable from LOW		65	200	ns	Figures 7 and 12; S_1 closed, S_2 open
Receiver Disable from HIGH		65	200	ns	Figures 7 and 12; S_2 closed, S_1 open
POWER REQUIREMENTS					
Supply Voltage	+3.0		+3.6	Volts	$\overline{REB}, D = 0V$ or $V_{CC}; DE = V_{CC}$
Supply Current		1000	2000	μA	
		800	1500	μA	$DE=0V$

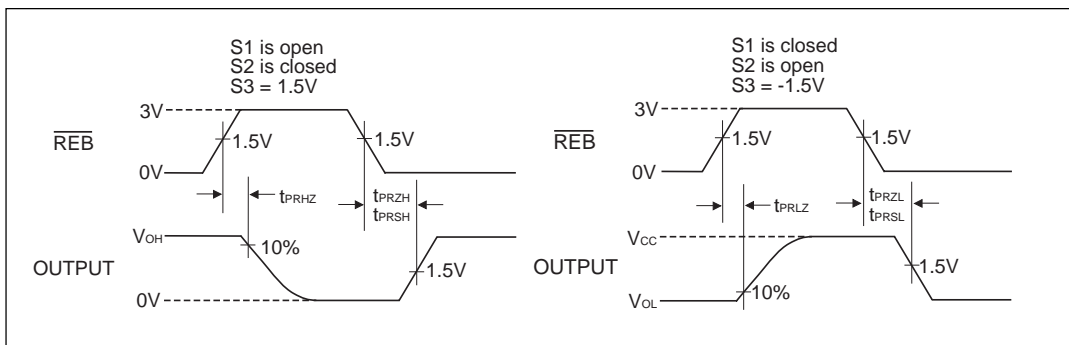

Figure 12. Receiver Enable and Disable Waveforms

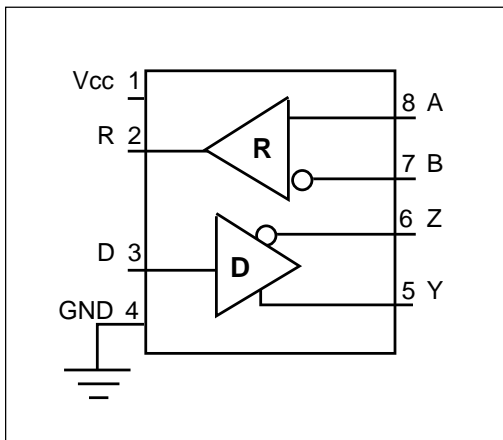

Figure 13. Pinout for the SP3490

PIN FUNCTION - SP3490

- Pin 1 - V_{CC} - Positive supply $+3.00 < V_{CC} < +3.60$
- Pin 2 - R - Receiver output.
- Pin 3 - D - Driver input.
- Pin 4 - GND - Ground connection.
- Pin 5 - Y - Non-inverting driver output.
- Pin 6 - Z - Inverting driver output.
- Pin 7 - B - Inverting receiver input.
- Pin 8 - A - Non-inverting receiver input.

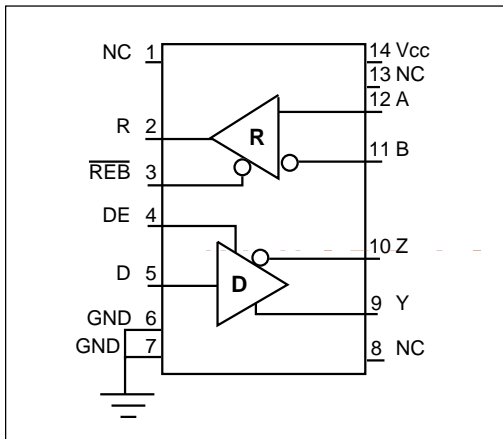

Figure 14. Pinout for the SP3491

PIN FUNCTION - SP3491

- Pin 1 - NC - No connect.
- Pin 2 - R - Receiver output.
- Pin 3 - REB - Receiver output enable active LOW.
- Pin 4 - DE - Driver output enable active HIGH.
- Pin 5 - D - Driver input.
- Pin 6 - GND - Ground connection.
- Pin 7 - GND - Ground connection.
- Pin 8 - NC - No connect.
- Pin 9 - Y - Non-inverting driver output.
- Pin 10 - Z - Inverting driver output.
- Pin 11 - B - Inverting receiver input.
- Pin 12 - A - Non-inverting receiver input.
- Pin 13 - NC - No connect.
- Pin 14 - V_{CC} - Positive supply $+3.00 < V_{CC} < +3.60$

DESCRIPTION

The **SP3490** and the **SP3491** are two members in the family of +3.3V low power full duplex transceivers that meet the electrical specifications of the RS-485 and RS-422 serial protocols. These devices are pin-to-pin compatible with the **Sipex SP490** and the **SP491** devices as well as popular industry standards. The **SP3490** and the **SP3491** feature **Sipex's** BiCMOS process allowing low power operation without sacrificing performance.

Driver

The drivers for both the **SP3490** and **SP3491** have differential outputs. The typical voltage output swing with no load will be 0 volts to V_{CC} . With a load of 54Ω across the differential outputs, the driver maintains greater than 1.5V voltage levels.

The driver of the **SP3491** has a driver enable control line which is active high. A logic high on DE (pin 4) of the **SP3491** will enable the differential driver outputs. A logic low on DE (pin 4) of the **SP3491** will tri-state the driver outputs. The **SP3490** does not have a driver enable.

Receiver

The receivers for the **SP3490** and **SP3491** have differential inputs with an input sensitivity as low as $\pm 100\text{mV}$. Input impedance of the receivers is typically $15\text{k}\Omega$ ($12\text{k}\Omega$ minimum). A wide common mode range of -7V to $+12\text{V}$ allows for large ground potential differences between systems. The receivers for both the **SP3490** and **SP3491** are equipped with a fail-safe feature that guarantees the receiver output will be in a high state when the input is left unconnected.

The receiver of the **SP3491** has a receiver enable control line which is active low. A logic low on REB (pin 3) of the **SP3491** will enable the differential receiver. A logic high on REB (pin 3) of the **SP3491** will tri-state the receiver.

**PACKAGE: PLASTIC
DUAL-IN-LINE
(NARROW)**

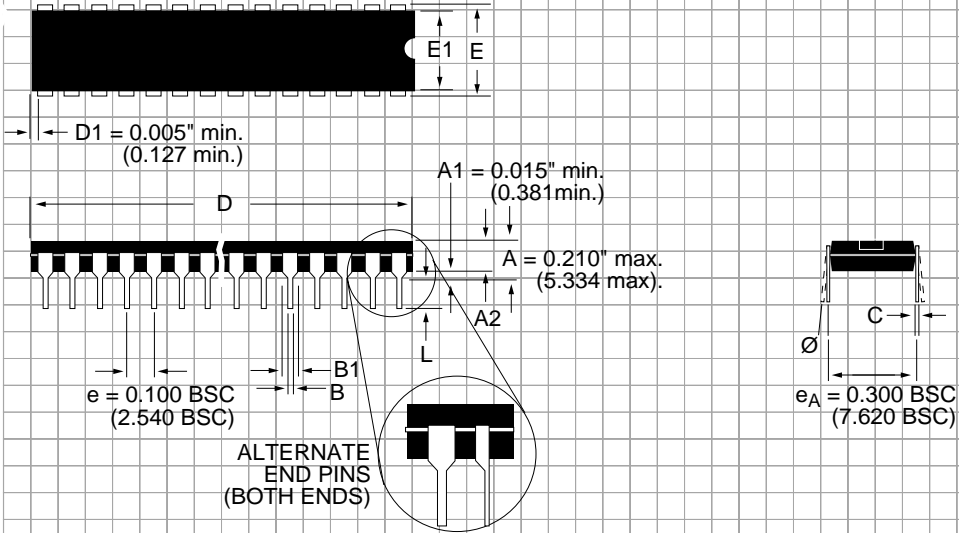

DIMENSIONS (Inches) Minimum/Maximum (mm)	8-PIN	14-PIN
A2	0.115/0.195 (2.921/4.953)	0.115/0.195 (2.921/4.953)
B	0.014/0.022 (0.356/0.559)	0.014/0.022 (0.356/0.559)
B1	0.045/0.070 (1.143/1.778)	0.045/0.070 (1.143/1.778)
C	0.008/0.014 (0.203/0.356)	0.008/0.014 (0.203/0.356)
D	0.355/0.400 (9.017/10.160)	0.735/0.775 (18.669/19.685)
E	0.300/0.325 (7.620/8.255)	0.300/0.325 (7.620/8.255)
E1	0.240/0.280 (6.096/7.112)	0.240/0.280 (6.096/7.112)
L	0.115/0.150 (2.921/3.810)	0.115/0.150 (2.921/3.810)
\emptyset	0°/ 15° (0°/15°)	0°/ 15° (0°/15°)

**PACKAGE: PLASTIC
SMALL OUTLINE (SOIC)
(NARROW)**

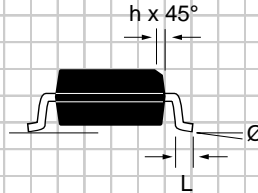
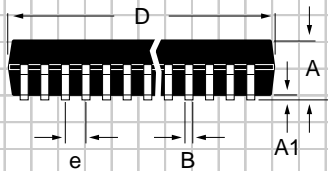
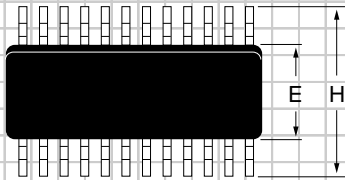

DIMENSIONS (Inches) Minimum/Maximum (mm)	8-PIN	14-PIN
A	0.053/0.069 (1.346/1.748)	0.053/0.069 (1.346/1.748)
A1	0.004/0.010 (0.102/0.249)	0.004/0.010 (0.102/0.249)
B	0.014/0.019 (0.35/0.49)	0.013/0.020 (0.330/0.508)
D	0.189/0.197 (4.80/5.00)	0.337/0.344 (8.552/8.748)
E	0.150/0.157 (3.802/3.988)	0.150/0.157 (3.802/3.988)
e	0.050 BSC (1.270 BSC)	0.050 BSC (1.270 BSC)
H	0.228/0.244 (5.801/6.198)	0.228/0.244 (5.801/6.198)
h	0.010/0.020 (0.254/0.498)	0.010/0.020 (0.254/0.498)
L	0.016/0.050 (0.406/1.270)	0.016/0.050 (0.406/1.270)
Ø	0°/8° (0°/8°)	0°/8° (0°/8°)

ORDERING INFORMATION

Model	Temperature Range	Package
SP3490CN	0°C to +70°C8-Pin NSOIC
SP3490CP	0°C to +70°C8-Pin DIP
SP3490EN	-40°C to +85°C8-Pin NSOIC
SP3490EP	-40°C to +85°C8-Pin DIP
SP3491CN	0°C to +70°C14-Pin NSOIC
SP3491CP	0°C to +70°C14-Pin DIP
SP3491EN	-40°C to +85°C14-Pin NSOIC
SP3491EP	-40°C to +85°C14-Pin DIP

Please consult the factory for pricing and availability on a Tape-On-Reel option.

Available in lead free packaging. To order, add "-L" suffix to the part number.
 Example: SP3490CN = standard; SP3490CN -L = lead free.



Sipex Corporation

Headquarters and Sales Office
 233 South Hillview Drive
 Milpitas, CA 95035
 TEL: (408) 934-7500
 FAX: (408) 935-7600

Sales Office
 22 Linnell Circle
 Billerica, MA 01821
 TEL: (978) 667-8700
 FAX: (978) 670-9001
 e-mail: sales@sipex.com

Sipex Corporation reserves the right to make changes to any products described herein. Sipex does not assume any liability arising out of the application or use of any product or circuit described herein, whether does it convey any license under its patent rights nor the rights of others.

www.BDTIC.com/Exar/