

## High-Voltage, Step Down Controller in TSOT6

**FEATURES**

- Wide 4.5V – 29V Input Voltage Range
- Internal Compensation
- Built-in High Current PMOS Driver
- Adjustable Overcurrent Protection
- Internal soft-start
- 600kHz Constant Frequency Operation
- 0.6V Reference Voltage
- 1% output setpoint accuracy
- Lead Free, RoHS Compliant Package: Small 6-Pin TSOT

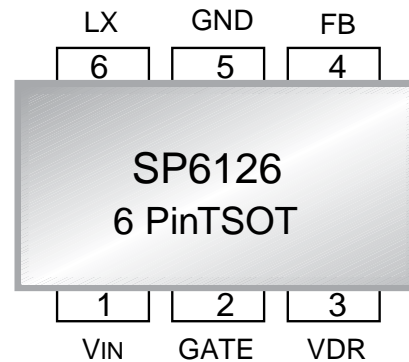

**DESCRIPTION**

The SP6126 is a PWM controlled step down (buck) voltage mode regulator with  $V_{IN}$  feedforward and internal Type-II compensation. It operates from 4.5V to 29V making it suitable for 5V, 12V, and 24V applications. By using a PMOS driver, this device is capable of operating at 100% duty cycle. The high side driver is designed to drive the gate 5V below  $V_{IN}$ . The programmable overcurrent protection is based on high-side MOSFET's ON resistance sensing and allows setting the overcurrent protection value up to 300mV threshold (measured from  $V_{IN}$ -LX). The SP6126 is available in a space-saving 6-pin TSOT package making it the smallest controller available capable of operating from 24VDC supplies.

**TYPICAL APPLICATION CIRCUIT**

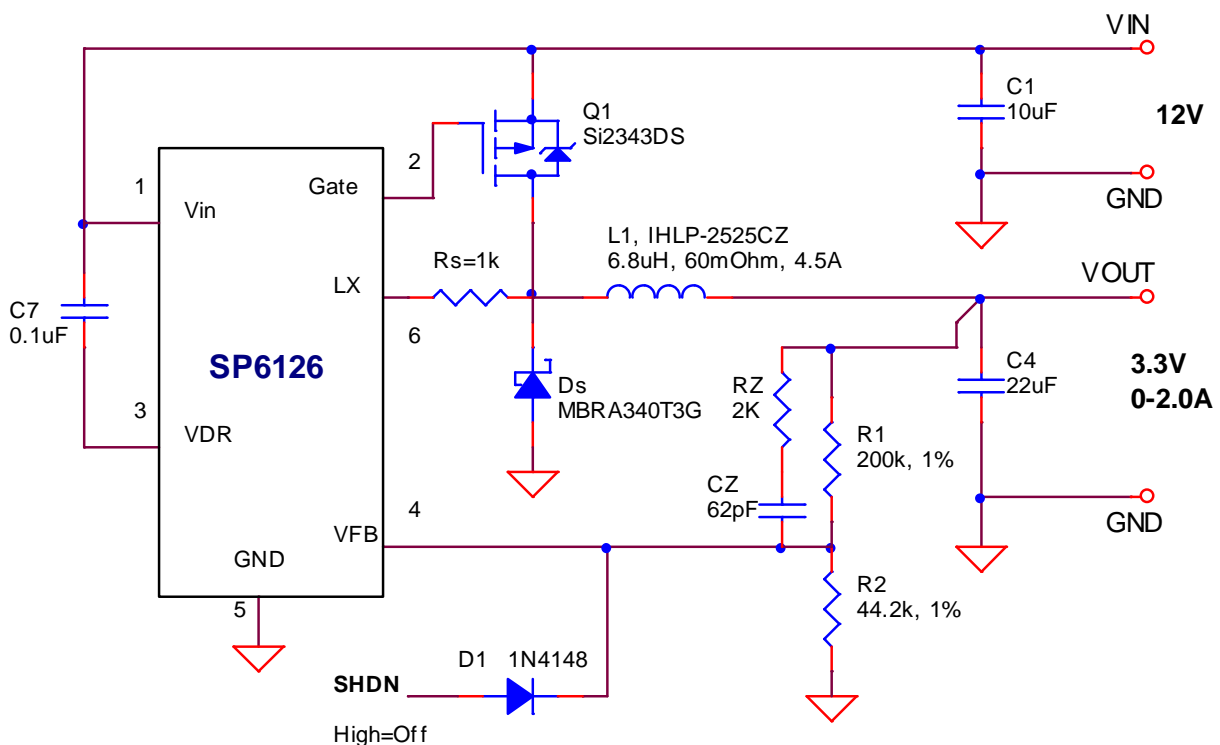



## ABSOLUTE MAXIMUM RATINGS

These are stress ratings only, and functional operation of the device at these ratings or any other above those indicated in the operation sections of the specifications below is not implied. Exposure to absolute maximum rating conditions for extended periods of time may affect reliability.

Input Voltage.....	-0.3V to 30V
LX.....	-2V to 30V
FB.....	-0.3V to 5.5V
Storage Temperature.....	-65 °C to 150 °C
Junction Temperature.....	-40°C to 125°C
Lead Temperature (Soldering, 10 sec).....	300 °C
ESD Rating.....	1kV LX, 2kV all other nodes, HBM

## ELECTRICAL SPECIFICATIONS

Specifications are for  $T_{AMB}=T_J=25^{\circ}\text{C}$ , and those denoted by  $\blacklozenge$  apply over the full operating range,  $-40^{\circ}\text{C} < T_J < 125^{\circ}\text{C}$ . Unless otherwise specified:  $V_{IN}=4.5\text{V}$  to  $29\text{V}$ ,  $C_{IN}=4.7\mu\text{F}$ .

PARAMETER	MIN	TYP	MAX	UNITS	◆	CONDITIONS
UVLO Turn-On Threshold	4.2	4.35	4.5	V		$0^{\circ}\text{C} < T_J < 125^{\circ}\text{C}$
UVLO Turn-Off Threshold	4.0	4.2	4.4	V		$0^{\circ}\text{C} < T_J < 125^{\circ}\text{C}$
UVLO Hysteresis		0.2		V		
Operating Input Voltage Range	4.5		29	V		$0^{\circ}\text{C} < T_J < 125^{\circ}\text{C}$
Operating Input Voltage Range	7		29	V	◆	
Operating VCC Current		0.3	3	mA		$V_{FB}=1.2\text{V}$
Reference Voltage Accuracy		0.5		%		
Reference Voltage Accuracy		0.5	2	%	◆	
Reference Voltage		0.6		V		
Reference Voltage	0.588	0.6	0.612	V	◆	
Switching Frequency	510	600	690	kHz		
Peak-to-peak ramp Modulator		$V_{IN}/5$		V		
Minimum ON-Time Duration		40	100	ns	◆	
Minimum Duty Cycle			0	%		
Maximum Duty Cycle	100			%		
Gate Driver Turn-Off Resistance		50	60	k $\Omega$		Internal resistor between GATE and $V_{IN}$
Gate Driver Pull-Down Resistance		4	8	$\Omega$		$V_{IN}=12\text{V}$ , $V_{FB}=0.5\text{V}$ , Measure resistance between GATE and VDR
Gate Driver Pull-up Resistance		3	6	$\Omega$		$V_{IN}=12\text{V}$ , $V_{FB}=0.7\text{V}$ , Measure resistance between GATE and $V_{IN}$
$V_{IN}$ - VDR voltage difference	4.5		5.5	V	◆	Measure $V_{IN}$ - VDR, $V_{IN}>7\text{V}$
Overcurrent Threshold	270	300	330	mV		Measure $V_{IN}$ - LX
LX pin Input Current	25	30	35	$\mu\text{A}$		$V_{LX} = V_{IN}$
OFF interval during hiccup		100		ms		
Soft start time	3	5	9	ms		$V_{FB}=0.58\text{V}$ , measure between $V_{IN}=4.5\text{V}$ and first GATE pulse
SHDN Threshold	0.9	1.0	1.1	V	◆	Apply voltage to FB
SHDN Threshold Hysteresis		100		mV		



## PIN DESCRIPTION

PIN #	PIN NAME	DESCRIPTION
1	VIN	Input power supply for the controller. Place input decoupling capacitor as close as possible to this pin.
2	GATE	Connect to the gate terminal of the external P-channel MOSFET.
3	VDR	Power supply for the internal driver. This voltage is internally regulated to about 5V below VIN. Place a 0.1uF decoupling capacitor between VDR and VIN as close as possible to the IC.
4	FB	Regulator feedback input. Connect to a resistive voltage-divider network to set the output voltage. This pin can be also used for ON/OFF control. If this pin is pulled above 1V the P-channel driver is disabled and controller resets internal soft start circuit.
5	GND	Ground pin.
6	LX	This pin is used as a current limit input for the internal current limit comparator. Connect to the drain pin of the external MOSFET through an optional resistor. Internal threshold is pre-set to 300mV nominal and can be decreased by changing the external resistor based on the following formula: $V_{TRSHLD} = 300\text{mV} - 30\mu\text{A} * R$

## BLOCK DIAGRAM

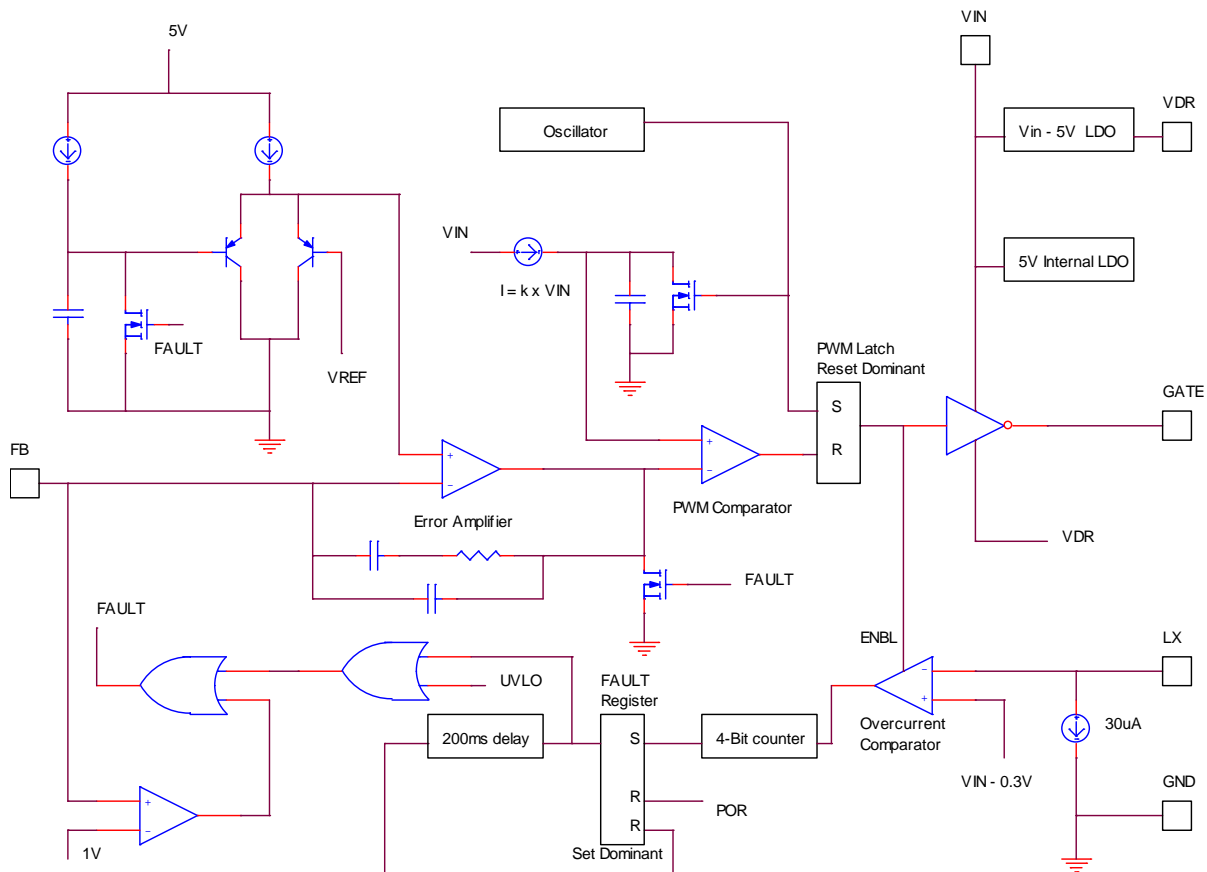

The SP6126 is a fixed frequency, voltage-mode, non-synchronous PWM controller optimized for minimum component, small form factor and cost effectiveness. It has been designed for single-supply operation ranging from 4.5V to 29V. SP6126 has Type-II internal compensation for use with Electrolytic/Tantalum output capacitors. For ceramic capacitors Type-III compensation can be implemented by simply adding an R and C between output and Feedback. A precision 0.6V reference, present on the positive terminal of the Error Amplifier, permits programming of the output voltage down to 0.6V via the FB pin. The output of the Error Amplifier is internally compared to a feed-forward (VIN/5 peak-to-peak) ramp and generates the PWM control. Timing is governed by an internal oscillator that sets the PWM frequency at 600kHz.

SP6126 contains useful protection features. Over-current protection is based on high-side MOSFET's Rds(on) and is programmable via a resistor placed at LX node. Under-Voltage Lock-Out (UVLO) ensures that the controller starts functioning only when sufficient voltage exists for powering IC's internal circuitry.

**SP6126 Loop Compensation**

The SP6126 includes Type-II internal compensation components for loop compensation. External compensation components are not required for systems with tantalum or aluminum electrolytic output capacitors with sufficiently high ESR. Use the condition below as a guideline to determine whether or not the internal compensation is sufficient for your design.

Type-II internal compensation is sufficient if the following condition is met:

$$f_{ESRZERO} < f_{DBPOLE} \dots\dots\dots (1)$$

where:

$$f_{ESRZERO} = \frac{1}{2\pi \cdot R_{ESR} \cdot C_{OUT}} \dots\dots\dots (2)$$

$$f_{DBPOLE} = \frac{1}{2\pi \cdot \sqrt{L} \cdot C_{OUT}} \dots\dots\dots (3)$$

**Creating a Type-III compensation Network**

The above condition requires the ESR zero to be at a lower frequency than the double-pole from the LC filter. If this condition is not met, Type-III compensation should be used and can be accomplished by placing a series RC combination in parallel with R1 as shown below. The value of CZ can be calculated as follows and RZ selected from table 1.

$$CZ = \frac{\sqrt{L \cdot C}}{R1} \dots\dots\dots (4)$$

$f_{ESRZERO} \div f_{DBPOLE}$	RZ
1X	50KΩ
2X	40KΩ
3X	30KΩ
5X	10KΩ
>= 10X	2KΩ

**Table1- Selection of RZ**

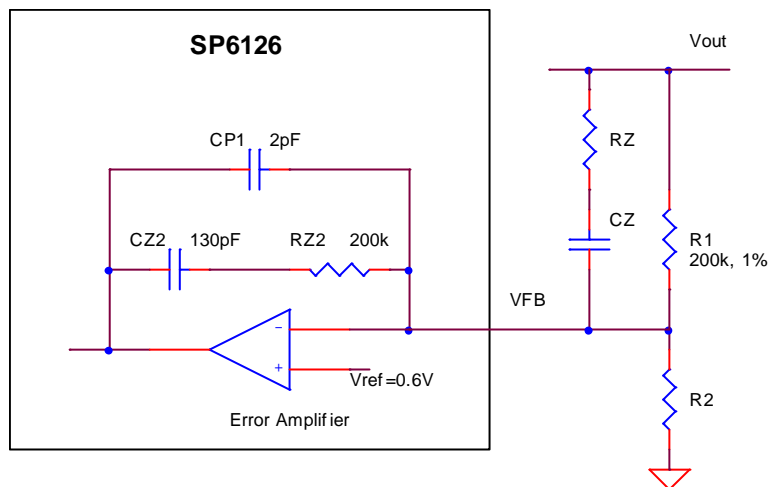

**Figure 1- RZ and CZ in conjunction with internal compensation components form a Type-III compensation**

Loop Compensation Example 1- A converter utilizing a SP6126 has a 6.8uH inductor and a 22uF/5mΩ ceramic capacitor. Determine whether Type-III compensation is needed.

From equation (2)  $f_{ESRZERO} = 1.45\text{MHz}$ . From equation (3)  $f_{DBPOLE} = 13\text{ kHz}$ . Since the condition specified in (1) is not met, Type-III compensation has to be used by adding external components RZ and CZ. Using equation (4) CZ is calculated 61.2pF (use 62 pF). Following the guideline given in table 1, a 2kΩ RZ should be used.

The steps followed in example 1 were used to compensate the typical application circuit shown on page 1. Satisfactory frequency response of the circuit, seen in figure 2, validates the above procedure.

Loop Compensation Example 2- A converter utilizing a SP6126 has a 6.8uH inductor and a 150uF, 82mΩ Aluminum Electrolytic capacitor. Determine whether Type-III compensation is needed.

From equation (2)  $f_{ESRZERO} = 13\text{kHz}$ . From equation (3)  $f_{DBPOLE} = 5\text{ kHz}$ . Since the condition specified in (1) is not met, Type-III compensation has to be used by adding external components RZ and CZ. Using equation (4) CZ is calculated 160pF (use 150 pF). Since  $f_{ESRZERO} \div f_{DBPOLE}$  is approximately 3, RZ has to be set at 30kΩ.

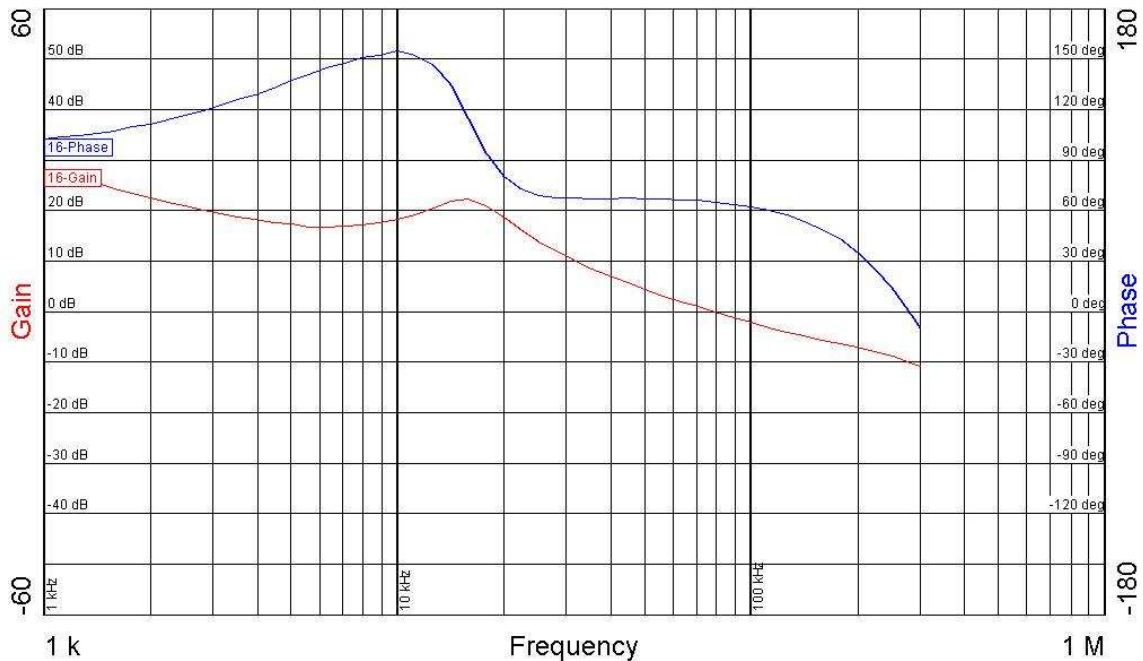

Figure 2- Satisfactory frequency response of typical application circuit shown on page 1. Crossover frequency  $f_c$  is 80kHz with a corresponding phase margin of 65 degrees.

**Overcurrent Protection**

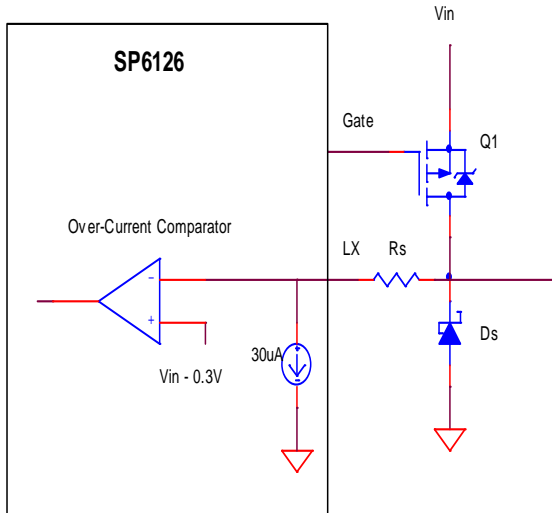

Figure 3- Overcurrent protection circuit

The overcurrent protection circuit functions by monitoring the voltage across the high-side FET Q1. When this voltage exceeds 0.3V, the overcurrent comparator triggers and the controller enters hiccup mode. For example if Q1 has  $R_{ds(on)}=0.1\Omega$ , then the overcurrent will trigger at  $I = 0.3V/0.1\Omega=3A$ . To program a lower overcurrent use a resistor  $R_s$  as shown in figure 1. Calculate  $R_s$  from:

$$R_s = \frac{0.3 - (1.15 \times I_{out} \times R_{ds(on)})}{30\mu A} \dots\dots\dots (5)$$

The overcurrent circuit triggers at peak current through Q1 which is usually about 15% higher than average output current. Hence the multiplier 1.15 is used in (5).

Example: A switching MOSFET used with SP6126 has  $R_{ds(on)}$  of  $0.1\Omega$ . Program the over-current circuit so that maximum output is 2A.

$$R_s = \frac{0.3 - (1.15 \times 1A \times 0.1\Omega)}{30\mu A}$$

$R_s = 2333\Omega$

Using the above equation there is good agreement between calculated and test results when an  $R_s$  in the range of 0.5k to 3k is used. For  $R_s$  larger than 3k test results are lower than those predicted by (5), due to circuit parasitics.

**Using the ON/OFF Function**

Feedback pin serves a dual role of ON/OFF control. The MOSFET driver is disabled when a voltage greater than 1V is applied at FB pin. Maximum voltage rating of this pin is 5.5V. The controlling signal should be applied through a small signal diode as shown on page 1. *Please note that an optional 10kΩ bleeding resistor across the output helps keep the output capacitor discharged under no load condition.*

**Programming the Output Voltage**

To program the output voltage, calculate  $R_2$  using the following equation:

$$R_2 = \frac{R_1}{\left(\frac{V_{out}}{V_{ref}} - 1\right)}$$

Where:  $V_{ref}=0.6$  is the reference voltage of the SP6126

$R_1=200k\Omega$  is a fixed-value resistor that, in addition to being a voltage divider, it is part of the compensation network. In order to simplify compensation calculations,  $R_1$  is fixed at  $200k\Omega$ .

**Soft Start**

Soft Start is preset internally to 5ms (nominal). Internal Soft Start eliminates the need for the external capacitor CSS that is commonly used to program this function.

**MOSFET Gate Drive**

P-channel drive is derived through an internal regulator that generates  $V_{IN-5V}$ . This pin (VDR) has to be connected to  $V_{IN}$  with a  $0.1\mu F$  decoupling capacitor. The gate drive circuit swings between  $V_{IN}$  and  $V_{IN-5}$  and employs powerful drivers for efficient switching of the P-channel MOSFET.

**Power MOSFET Selection**

Select the Power MOSFET for Voltage rating  $BV_{DSS}$ , On resistance  $R_{DS(ON)}$ , and thermal resistance  $R_{thja}$ .  $BV_{DSS}$  should be about twice as high as  $V_{IN}$  in order to guard against switching transients. Recommended MOSFET voltage rating for  $V_{IN}$  of 5V, 12V and 24V is 12V, 30V and 40V respectively.  $R_{DS(ON)}$  has to be selected such that when operating at peak current and junction temperature the Overcurrent threshold of the SP6126 is not exceeded. Allowing 50% for temperature coefficient of  $R_{DS(ON)}$  and 15% for inductor current ripple, the following expression can be used:

$$R_{DS(ON)} \leq \left( \frac{300mV}{1.5 \times 1.15 \times I_{out}} \right)$$

Within this constraint, selecting MOSFETs with lower  $R_{DS(ON)}$  will reduce conduction losses at the expense of increased switching losses. As a rule of thumb select the highest  $R_{DS(ON)}$  MOSFET that meets the above criteria. Switching losses can be assumed to roughly equal the conduction losses. A simplified expression for conduction losses is given by:

$$P_{cond} = I_{out} \times R_{DS(ON)} \times \left( \frac{V_{out}}{V_{in}} \right)$$

MOSFET's junction temperature can be estimated from:

$$T = (2 \times P_c \times R_{thja}) + T_{ambient}$$

**Schottky Rectifier selection**

Select the Schottky for Voltage rating  $V_R$ , Forward voltage  $V_f$ , and thermal resistance  $R_{thja}$ . Voltage rating should be selected using the same guidelines outlined for MOSFET voltage selection. For a low duty cycle application such as the circuit shown on first page, the Schottky is conducting most of the time and its conduction losses are the largest component of losses in the converter. Conduction losses can be estimated from:

$$P_c = V_f \times I_{out} \times \left( 1 - \frac{V_{out}}{V_{in}} \right)$$

where:

$V_f$  is diode forward voltage at  $I_{OUT}$

Schottky's AC losses due to its switching capacitance are negligible.

**Inductor Selection**

Select the Inductor for inductance  $L$  and saturation current  $I_{SAT}$ . Select an inductor with  $I_{SAT}$  higher than the programmed overcurrent. Calculate inductance from:

$$L = (V_{in} - V_{out}) \times \left( \frac{V_{out}}{V_{in}} \right) \times \left( \frac{1}{f} \right) \times \left( \frac{1}{I_{rip}} \right)$$

where:

$V_{IN}$  is converter input voltage

$V_{OUT}$  is converter output voltage

$f$  is switching frequency

$I_{RIP}$  is inductor peak-to-peak current ripple (nominally set to 30% of  $I_{OUT}$ )

Keep in mind that a higher  $I_{RIP}$  results in a smaller inductor which has the advantages of small size, low DC equivalent resistance DCR, high saturation current  $I_{SAT}$  and allows the use of a lower output capacitance to meet a given step load transient. A higher  $I_{RIP}$ , however, increases the output voltage ripple and increases the current at which converter enters Discontinuous Conduction Mode. The output current at which converter enters DCM is  $\frac{1}{2}$  of  $I_{RIP}$ . Note that a negative current step load that drives the converter into DCM will result in a large output voltage transient. Therefore the lowest current for a step load should be larger than  $\frac{1}{2}$  of  $I_{RIP}$ .

**Output Capacitor Selection**

Select the output capacitor for voltage rating, capacitance and Equivalent Series Resistance (ESR). Nominally the voltage rating is selected to be twice as large as the output voltage. Select the capacitance to satisfy the specification for output voltage overshoot/undershoot caused by current step load. A steady-state output current  $I_{OUT}$  corresponds to inductor stored energy of  $\frac{1}{2} L I_{OUT}^2$ .

A sudden decrease in I<sub>OUT</sub> forces the energy surplus in L to be absorbed by C<sub>OUT</sub>. This causes an overshoot in output voltage that is corrected by power switch reduced duty cycle. Use the following equation to calculate C<sub>OUT</sub>:

$$C_{out} = L \times \left( \frac{I_2^2 - I_1^2}{V_{os}^2 - V_{out}^2} \right)$$

Where:

L is the output inductance  
 I<sub>2</sub> is the step load high current  
 I<sub>1</sub> is the step load low current  
 V<sub>os</sub> is output voltage including overshoot  
 V<sub>OUT</sub> is steady state output voltage

Output voltage undershoot calculation is more complicated. Test results for SP6126 buck circuits show that undershoot is approximately equal to overshoot. Therefore above equation provides a satisfactory method for calculating C<sub>OUT</sub>.

Select ESR such that output voltage ripple (VRIP) specification is met. There are two components to VRIP: First component arises from charge transferred to and from C<sub>OUT</sub> during each cycle. The second component of VRIP is due to inductor ripple current flowing through output capacitor's ESR. It can be calculated from:

$$V_{rip} = I_{rip} \times \sqrt{ESR^2 + \left( \frac{1}{8 \times C_{out} \times f_s} \right)^2}$$

Where:

I<sub>RIP</sub> is inductor ripple current  
 f<sub>s</sub> is switching frequency  
 C<sub>OUT</sub> is output capacitor calculated above

Note that a smaller inductor results in a higher I<sub>RIP</sub>, therefore requiring a larger C<sub>OUT</sub> and/or lower ESR in order to meet VRIP.

### Input Capacitor Selection

Select the input capacitor for Voltage, Capacitance, ripple current, ESR and ESL. Voltage rating is nominally selected to be twice the input voltage. The RMS value of input capacitor current, assuming a low inductor ripple current (I<sub>RIP</sub>), can be calculated from:

$$I_{cin} = I_{out} \times \sqrt{D(1-D)}$$

In general total input voltage ripple should be kept below 1.5% of V<sub>IN</sub> (not to exceed 180mV). Input voltage ripple has three components: ESR and ESL cause a step voltage drop upon turn on of the MOSFET. During on time capacitor discharges linearly as it supplies I<sub>OUT</sub>-lin. The contribution to Input voltage ripple by each term can be calculated from:

$$\Delta V, C_{in} = \frac{I_{out} \times V_{out} \times (V_{in} - V_{out})}{f_s \times C_{in} \times V_{in}^2}$$

$$\Delta V, ESR = ESR(I_{out} - 0.5I_{rip})$$

$$\Delta V, ESL = ESL \frac{(I_{out} - 0.5I_{rip})}{Trise}$$

Where Trise is the rise time of current through capacitor

Total input voltage ripple is sum of the above:

$$\Delta V, Tot = \Delta V, C_{in} + \Delta V, ESR + \Delta V, ESL$$



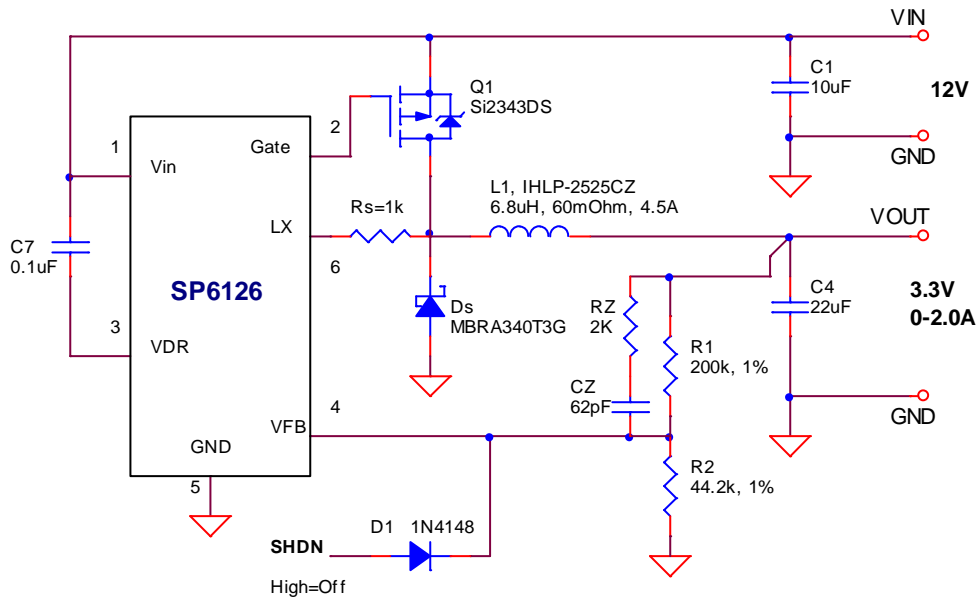

Figure 4- Application circuit for VIN=12V

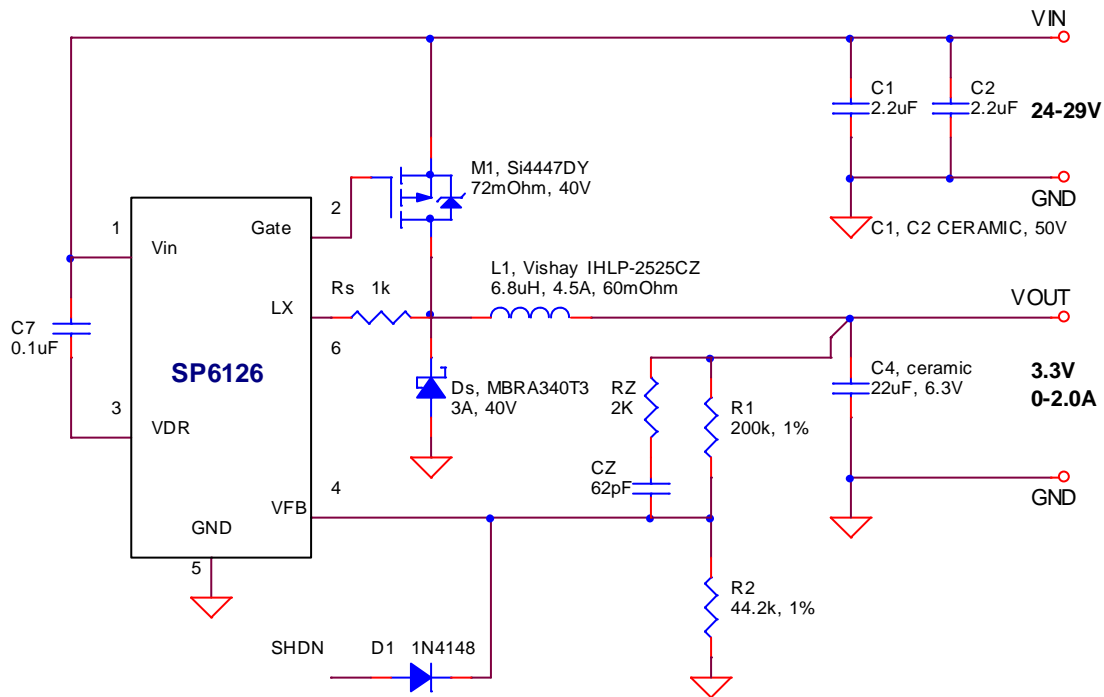

Figure 5- Application circuit for VIN = 24-29V

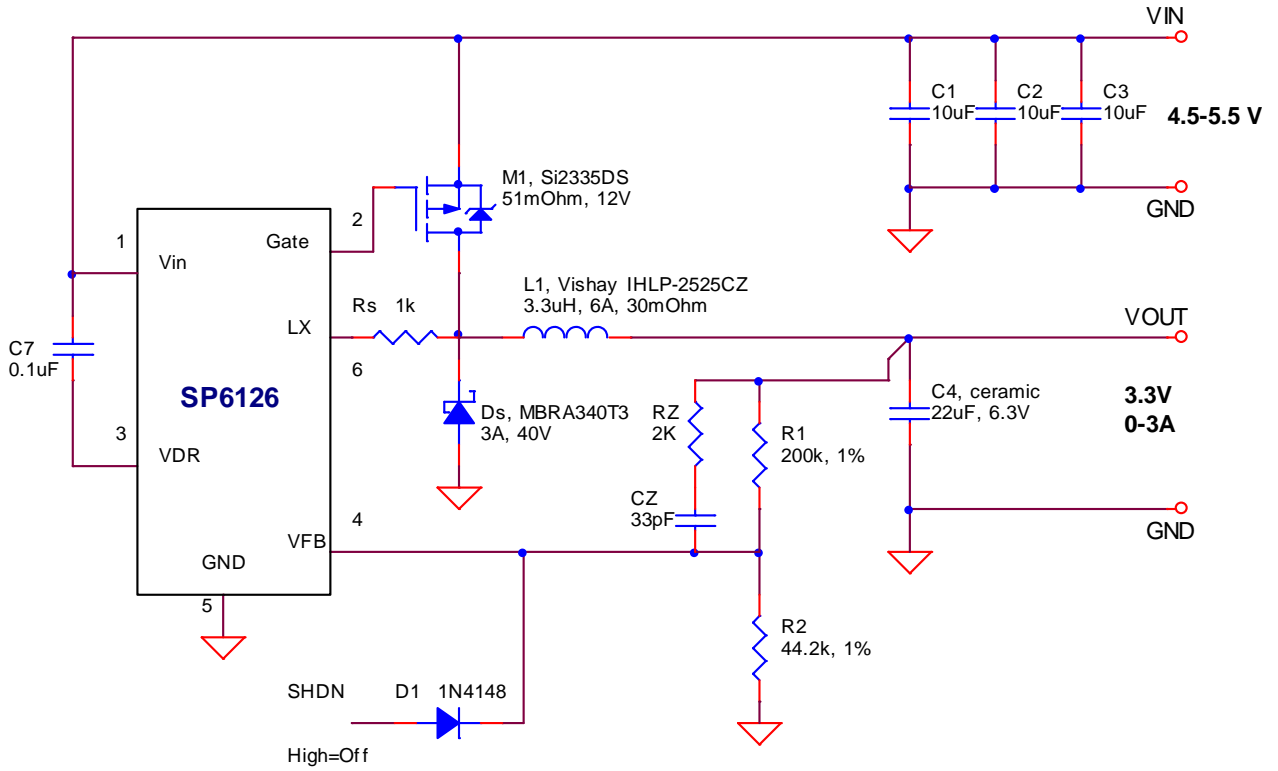

Figure 6- Application circuit for  $V_{OUT} = 4.5-5.5\text{ V}$

TYPICAL PERFORMANCE CHARACTERISTICS

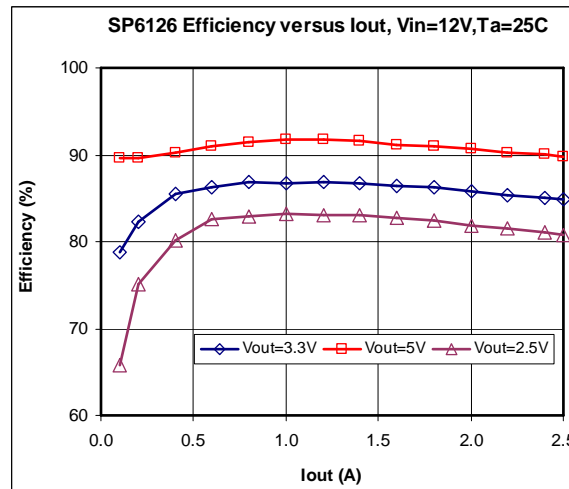

Figure 7- Efficiency at  $V_{IN} = 12\text{ V}$



## TYPICAL PERFORMANCE CHARACTERISTICS

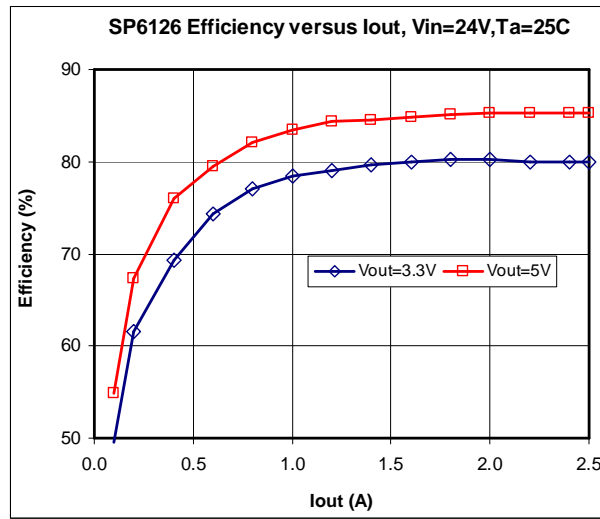

Figure 8- Efficiency at VIN = 24 V

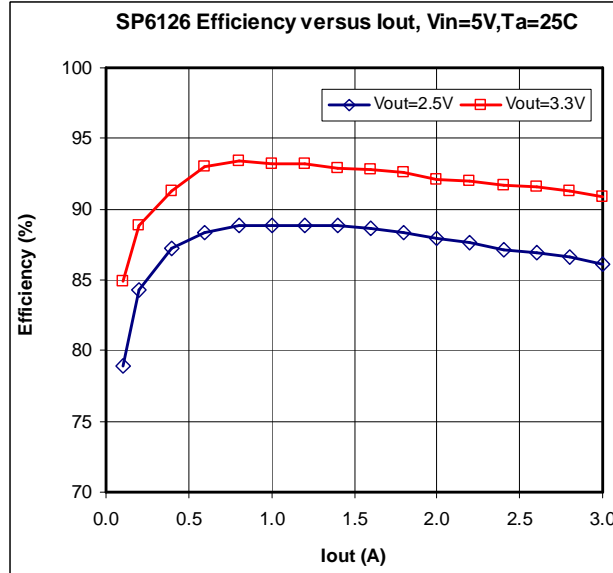
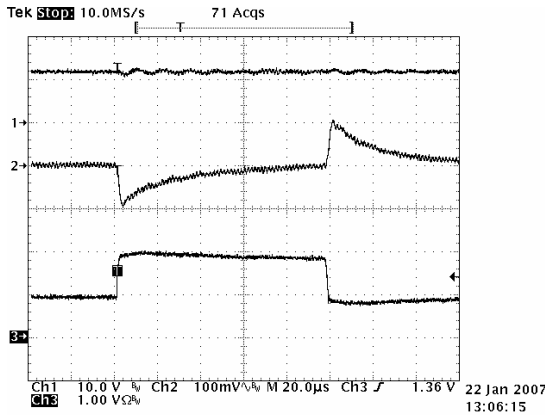

Figure 9- Efficiency at VIN = 5 V



## TYPICAL PERFORMANCE CHARACTERISTICS



**Figure 10- Step load 1-2A,  
ch1: VIN; ch2: VOUT; ch3: IOUT**

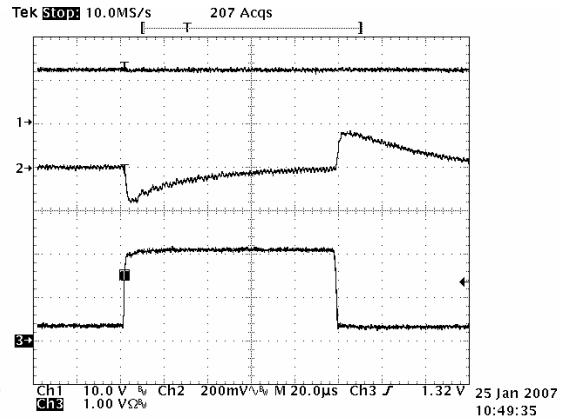

**Figure 11- Step load 0.3-2A,  
ch1: VIN; ch2: VOUT; ch3: IOUT**

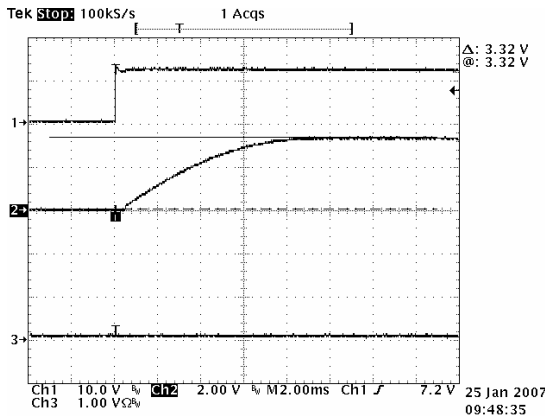

**Figure 12- Startup no load,  
ch1: VIN ch2: VOUT, ch3: IOUT**

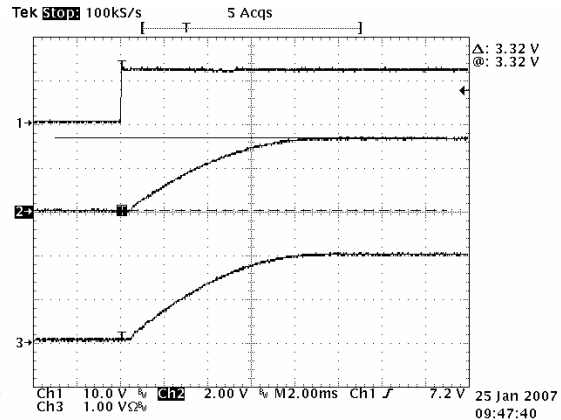

**Figure 13- Start up 2A,  
ch1: VIN; ch2: VOUT; ch3: IOUT**

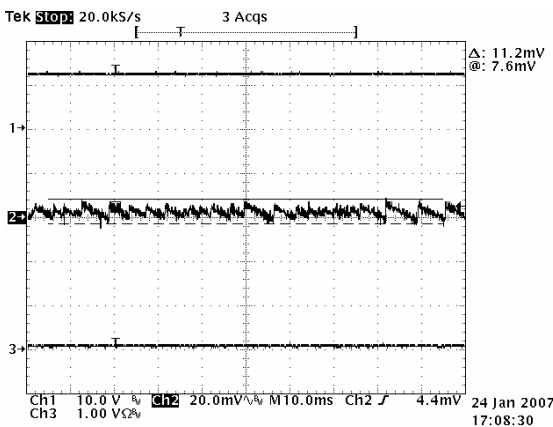

**Figure 14- Output ripple at 0A is 11mV,  
ch1: VIN; ch2: VOUT; ch3: IOUT**

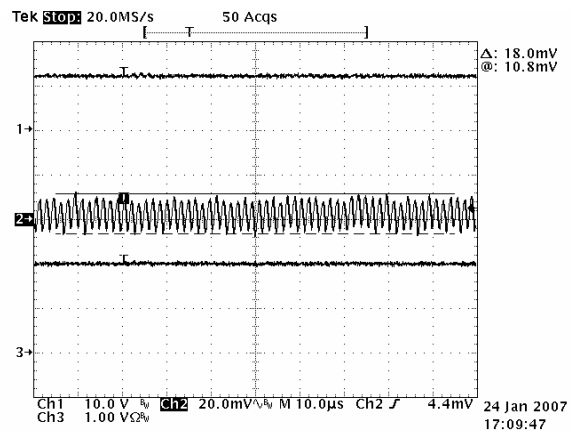

**Figure 15- Output ripple at 2A is 18mV,  
ch1: VIN; ch2: VOUT; ch3: IOUT**

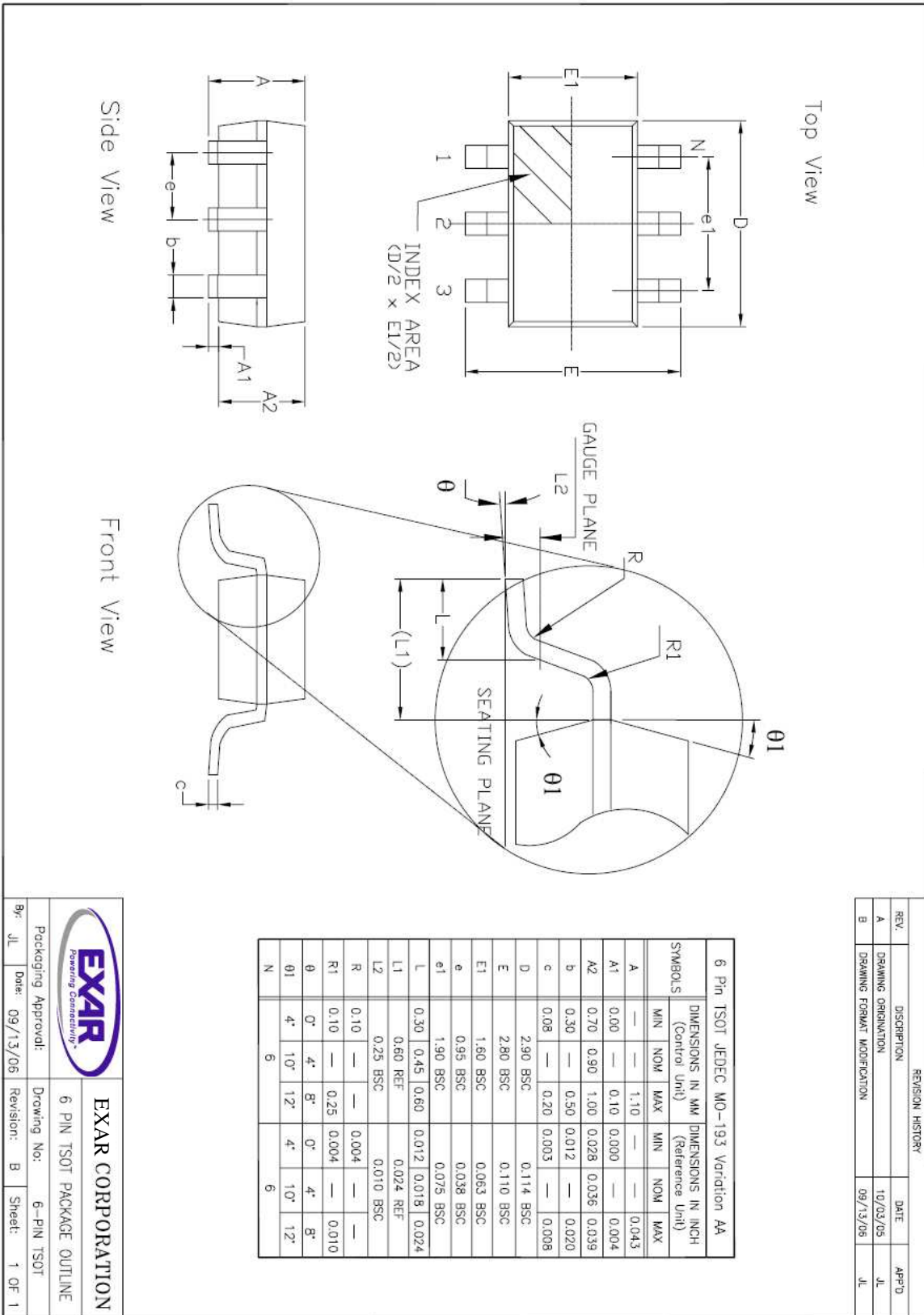

REVISION HISTORY			
REV	DESCRIPTION	DATE	APP'D
A	DRAWING ORIGINATOR	10/03/05	JL
B	DRAWING FORMAT MODIFICATION	09/13/06	JL

**EXAR CORPORATION**  
 Packaging Approval: 6 PIN TSOT PACKAGE OUTLINE  
 Drawing No: 6-PIN TSOT  
 Revision: B Sheet: 1 OF 1  
 Date: 09/13/06



**ORDERING INFORMATION**

<b>Part Number</b>	<b>Temperature Range</b>	<b>Package</b>
SP6126EK1-L.....	-40°C to +125°C.....	(Lead Free) 6 Pin TSOT
SP6126EK1-L/TR.....	-40°C to +125°C.....	(Lead Free) 6 Pin TSOT

/TR = Tape and Reel  
Pack Quantity for Tape and Reel is 2500

For further assistance:

Email: [customersupport@exar.com](mailto:customersupport@exar.com)  
EXAR Technical Documentation: <http://www.exar.com/TechDoc/default.aspx?>



**Exar Corporation  
Headquarters and  
Sales Office**  
48720 Kato Road  
Fremont, CA 94538  
main: 510-668-7000  
fax: 510-668-7030

EXAR Corporation reserves the right to make changes to the products contained in this publication in order to improve design, performance or reliability. EXAR Corporation assumes no responsibility for the use of any circuits described herein, conveys no license under any patent or other right, and makes no representation that the circuits are free of patent infringement. Charts and schedules contained here in are only for illustration purposes and may vary depending upon a user's specific application. While the information in this publication has been carefully checked; no responsibility, however, is assumed for inaccuracies.

EXAR Corporation does not recommend the use of any of its products in life support applications where the failure or malfunction of the product can reasonably be expected to cause failure of the life support system or to significantly affect its safety or effectiveness. Products are not authorized for use in such applications unless EXAR Corporation receives, in writing, assurances to its satisfaction that: (a) the risk of injury or damage has been minimized; (b) the user assumes all such risks; (c) potential liability of EXAR Corporation is adequately protected under the circumstances.