

# 600mA Low Dropout Voltage Regulator

## FEATURES

- Guaranteed 600mA Output
- Three Terminal Adjustable or Fixed 2.5V, 3V and 3.3V
- Low Quiescent Current
- Low Dropout Voltage of 1.1V at Full Load
- 0.2% Line and 0.3% Load Regulation
- Voltage Temperature Stability 0.05%
- Overcurrent and Thermal Protection
- Available Packages: SOT-223, TO-252, TO-220, and TO-263

## APPLICATIONS

- SCSI-II Active Terminator
- Portable/ Palm Top / Notebook Computers
- Battery Chargers
- Disk Drives
- Available Consumer Equipment Packaging
- Portable Instrumentation
- SMPS Post-Regulator

*Now Available in Lead Free Packaging*

Refer to page 6 for pinouts.

## DESCRIPTION

The SPX1202 is a low power positive-voltage regulator designed to satisfy moderate power requirements with a cost effective, small footprint solution. This device is an excellent choice for use in battery-powered applications and portable computers. The SPX1202 features very low quiescent current and a low dropout voltage of 1.1V at a full load. As output current decreases, quiescent current flows into the load, increasing efficiency. SPX1202 is available in adjustable or fixed 2.5V, 3V and 3.3V output voltages.

The SPX1202 is offered in several 3-pin surface mount packages: SOT-223, TO-252, TO-220 and TO-263. An output capacitor of 10 $\mu$ F provides unconditional stability while a smaller 2.2 $\mu$ F capacitor is sufficient for most applications.

## BLOCK DIAGRAM

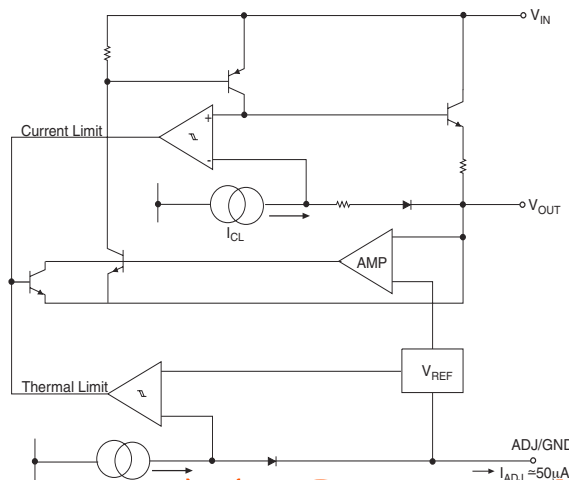

## ABSOLUTE MAXIMUM RATINGS

Power Dissipation ..... Internally Limited  
 Lead Temperature (soldering, 5 seconds) ..... 260°C  
 Storage Temperature Range ..... -65°C to +150°C

Operating Junction Temperature Range ..... -40°C to +125°C  
 Input Supply Voltage ..... +20V  
 ESD Rating ..... 2kV min

## ELECTRICAL CHARACTERISTICS

at  $V_{IN} = V_{OUT} + 1.5V$ ,  $T_A = 25^\circ C$ ,  $C_{IN} = C_{OUT} = 10\mu F$ , unless otherwise specified. Limits in **Boldface** applies over the full operating temperature range.

PARAMETER	CONDITIONS	TYP	MIN	MAX	UNITS
<b>2.5V Version</b>					
Output Voltage	$I_{OUT} = 10mA, V_{IN} = 5.00V$ $0 \leq I_{OUT} \leq 600mA, 4.50V \leq V_{IN} \leq 10V$	2.475 <b>2.450</b>	2.500	2.525 <b>2.550</b>	V
<b>3.0V Version</b>					
Output Voltage	$I_{OUT} = 10mA, V_{IN} = 5.00V$ $0 \leq I_{OUT} \leq 600mA, 4.50V \leq V_{IN} \leq 10V$	2.970 <b>2.940</b>	3.000	3.030 <b>3.060</b>	V
<b>3.3V Version</b>					
Output Voltage	$I_{OUT} = 10mA, V_{IN} = 5.00V$ $0 \leq I_{OUT} \leq 600mA, 4.50V \leq V_{IN} \leq 10V$	3.267 <b>3.234</b>	3.300	3.333 <b>3.366</b>	V
<b>All Output Options</b>					
Reference Voltage	$I_{OUT} = 10mA, (V_{IN} - V_{OUT}) = 2V$ $10 \leq I_{OUT} \leq 600mA, 1.4V \leq (V_{IN} - V_{OUT}) \leq 10V$	1.238 <b>1.225</b>	1.250	1.262 <b>1.270</b>	V
Output Voltage Temperature Stability	(Note 1)			<b>0.05</b>	%
Line Regulation	$4.50V \leq V_{IN} \leq 12V, V_{OUT} = 3.00, I_{OUT} = 0$ $4.80V \leq V_{IN} \leq 12V, V_{OUT} = 3.30, I_{OUT} = 0$ $6.50V \leq V_{IN} \leq 12V, V_{OUT} = 5.00, I_{OUT} = 0$		1.00 1.00 1.00	7.00 7.00 10.00	mV
Load Regulation	$0 \leq I_{OUT} \leq 600mA, V_{IN} = 4.50V, V_{OUT} = 3.00$ $0 \leq I_{OUT} \leq 600mA, V_{IN} = 4.80V, V_{OUT} = 3.30$ $0 \leq I_{OUT} \leq 600mA, V_{IN} = 6.50V, V_{OUT} = 5.0$		1.00 1.00 1.00	12.00 12.00 15.00	mV
Dropout Voltage (Note 2)	$I_L = 100mA$ $I_L = 600mA$		1.00 1.05	1.10 1.15	V
Quiescent Current	$4.25V \leq V_{IN} \leq 6.5V$		5.00	10.00	mA
Adjust Pin Current			50		$\mu A$
Current Limit	$(V_{IN} - V_{OUT}) = 5V$		.850	1.0	A
Thermal Regulation	25°C, 30mS Pulse		0.01	0.1	%/W
Ripple Rejection	$f_{RIPPLE} = 120Hz, (V_{IN} - V_{OUT}) = 3V,$ $V_{RIPPLE} = 1V_{PP}$		60	75	dB
Long Term Stability	125°C, 1000Hrs			0.03	%
RMS Output Noise	% of $V_{OUT}$ , 10Hz $\leq f \leq$ 10kHz			0.003	%
Thermal Resistance	Junction to Case, at tab			15	$^\circ C/W$

### NOTES:

Note 1: Output temperature coefficient is defined as the worst case voltage change divided by the total temperature range.

Note 2: Dropout voltage is defined as the input to output differential at which the output voltage drops 100mV below its nominal value measured at 1V differential at very low values of programmed output voltage, the minimum input supply voltage of 2V (2.3V over temperature) must be taken into account.

Note 3: Thermal regulation is defined as the change in input voltage  $\Delta V_{IN}$  at a change in power dissipation is applied excluding load or line regulation effects.

[www.BDTC.com/Exar/](http://www.BDTC.com/Exar/)

# TYPICAL PERFORMANCE CHARACTERISTICS

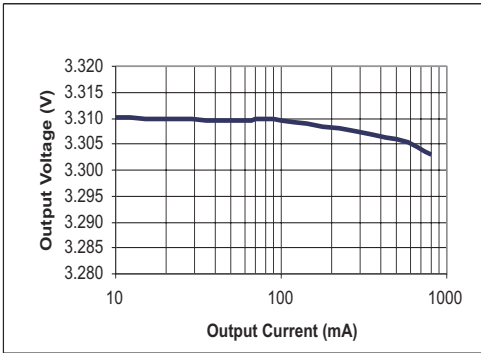

Figure 1. Load Regulation for SPX1202M3-3.3;  
 $V_{IN}=4.8V$ ,  $C_{OUT}=2.2\mu F$

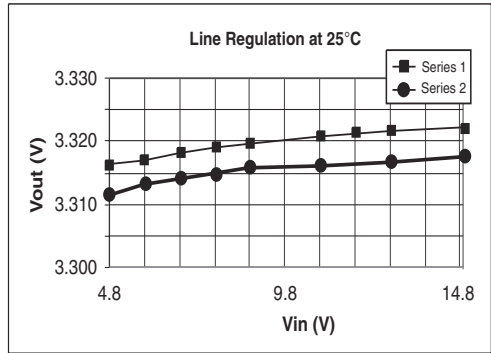

Figure 2. Line Regulation for SPX1202M3-3.3;  
 $V_{IN}=4.8V$  to  $16V$ ,  $C_{OUT}=2.2\mu F$

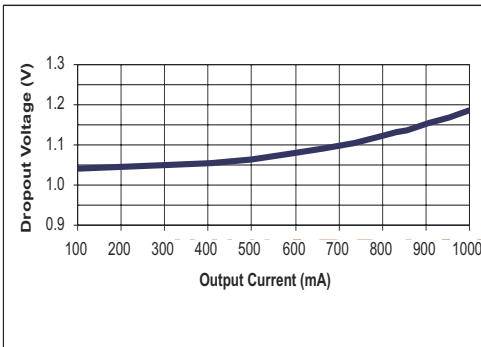

Figure 3. Dropout Voltage vs Output Current for SPX1202M3-3.3;  $V_{IN}=4.89V$ ,  $C_{OUT}=2.2\mu F$

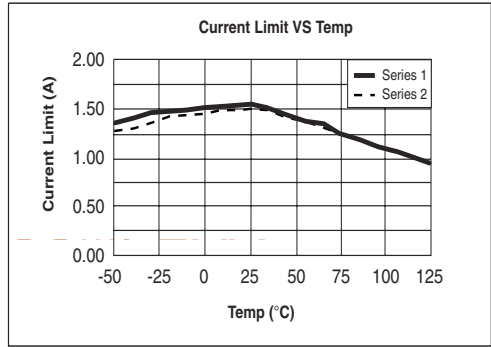

Figure 4. Current Limit for SPX1202M3-3.3;  $V_{IN}=4.8V$ ,  
 $C_{IN}=C_{OUT}=1.0\mu F$ ,  $I_{OUT}$  pulsed from 10mA to Current Limit

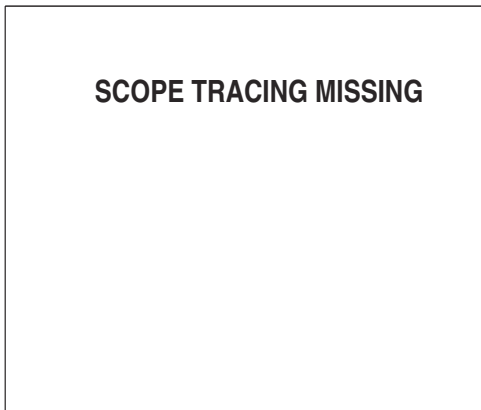

Figure 5. Current Limit for SPX1202M3-3.3, Output Voltage Deviation with  $I_{OUT}=10mA$  to 1A Step.

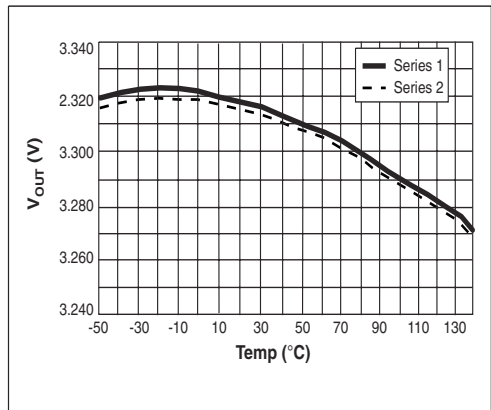

Figure 6.  $V_{OUT}$  vs Temperature  $I_{OUT}$  pulsed from 10mA to Current Limit

## APPLICATION INFORMATION

### Output Capacitor

To ensure the stability of the SPX1202, an output capacitor of at least 10 $\mu$ F (tantalum or ceramic) or 50 $\mu$ F (aluminum) is required. The value may change based on the application requirements of the output load or temperature range. The value of ESR can vary based on the type of capacitor used in the applications. The recommended value for ESR is 0.5 $\Omega$  or less. A larger value of output capacitance (up to 100 $\mu$ F) can improve the load transient response.

### SOLDERING METHODS

The SPX1202 SOT-223 package is designed to be compatible with infrared reflow or vapor-phase reflow soldering techniques. During soldering, the non-active or mildly active fluxes may be used. The SPX1202 die is attached to the heatsink lead which exits opposite the input, output, and ground pins.

Hand soldering and wave soldering should be avoided since these methods can cause damage to the device with excessive thermal gradients on the package. The SOT-223 recommended soldering method are as follows: vapor phase reflow and infrared reflow with the component preheated to within 65 $^{\circ}$ C of the soldering temperature range

### THERMAL CHARACTERISTICS

The thermal resistance of SPX1202 depends on the type of package and PC board layout as shown in Table 1. The SPX1202 features the internal thermal limiting to protect the device during overload conditions. Special care needs to be taken during continuous load conditions such that the maximum junction temperature does not exceed 125 $^{\circ}$ C. Thermal protection is activated at >144 $^{\circ}$ C and deactivated at <137 $^{\circ}$ C.

Taking the FR-4 printed circuit board and 1/16 thick with 1 ounce copper foil as an experiment, the PCB material is effective at transmitting heat with the tab attached to the pad area and a ground plane layer on the backside of the substrate. Refer to table 1 for the results of the experiment.

The thermal interaction from other components

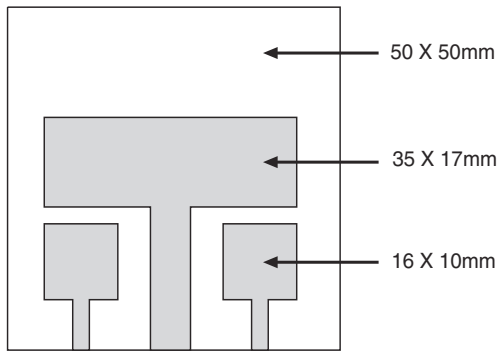

Figure 7. Substrate Layout for SOT-223

in the application can effect the thermal resistance of the SPX1202. The actual thermal resistance can be determined with experimentation.

SPX1202 power dissipation is calculated as follows:

$$P_D = (V_{IN} - V_{OUT})(I_{OUT})$$

Maximum Junction Temperature range:

$$T_J = T_{AMBIENT}(\max) + P_D * (\text{Thermal Resistance})$$

(Junction-to-ambient)

Maximum junction temperature must not exceed the 125 $^{\circ}$ C.

### Ripple Rejection

Ripple rejection can be improved by adding a capacitor between the ADJ pin and ground as shown in Figure 7. When ADJ pin bypassing is used, the value of the output capacitor required increases to its maximum. If the ADJ pin is not bypassed, the value of the output capacitor can be lowered to 10 $\mu$ F for an electrolytic aluminum capacitor or 2.2 $\mu$ F for a solid tantalum capacitor (Fig 10).

However the value of the ADJ-bypass capacitor should be chosen with respect to the following equation:

$$C = 1 / ( 6.28 * F_R * R_1 )$$

Where C = value of the capacitor in Farads (select an equal or larger standard value),

$F_R$  = ripple frequency in Hz,

$R_1$  = value of resistor  $R_1$  in Ohms.

If an ADJ-bypass capacitor is used, the ampli-

tude of the output ripple will be independent of the output voltage. If an ADJ-bypass capacitor is not used, the output ripple will be proportional to the ratio of the output voltage to the reference voltage:

$$M = V_{OUT} / V_{REF}$$

Where M = multiplier for the ripple seen when the ADJ pin is optimally bypassed.

$$V_{REF} = 1.25V$$

## Output Voltage

The output of the adjustable regulator can be set to any voltage between 1.25V and 15V. The value of  $V_{OUT}$  can be quickly approximated using the formula. (Figure 9)

$$V_{OUT} = 1.25 * (R_1 + R_2) / R_1$$

A small correction to this formula is required depending on the values of resistors R1 and R2, since adjustable pin current (approx 50µA) flows through R2. When  $I_{ADJ}$  is taken into account, the formula becomes

$$V_{OUT} = V_{REF} (1 + (R_2/R_1)) + I_{ADJ} * R_2,$$

where  $V_{REF} = 1.25V$ .

PC BOARD AREA mm <sup>2</sup>	TOPSIDE COPPER AREA mm <sup>2</sup>	BACKSIDE COPPER AREA mm <sup>2</sup>	THERMAL RESISTANCE JUNCTION TO AMBIENT °C/W
2500	2500	2500	46
2500	1250	2500	47
2500	950	2500	49
2500	2500	0	51
2500	1800	0	53
1600	600	1600	55
2500	1250	0	58
2500	915	0	59
1600	600	0	67
900	240	900	72
900	240	0	85

Table 1

## TYPICAL APPLICATIONS

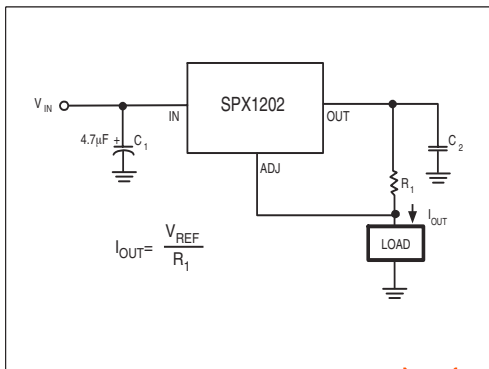

Figure 8 600 mA Current Source

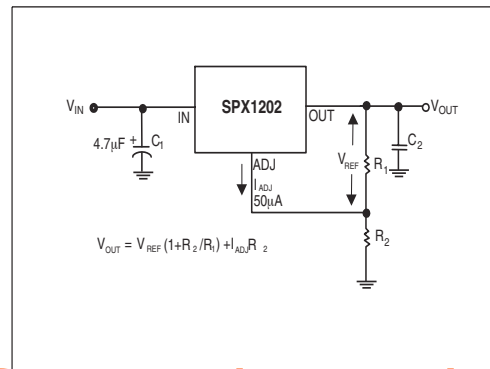

Figure 9 Typical Adjustable Regulator

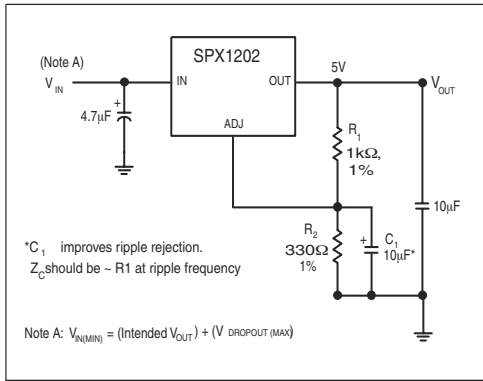

Figure 10. Improving Ripple Rejection

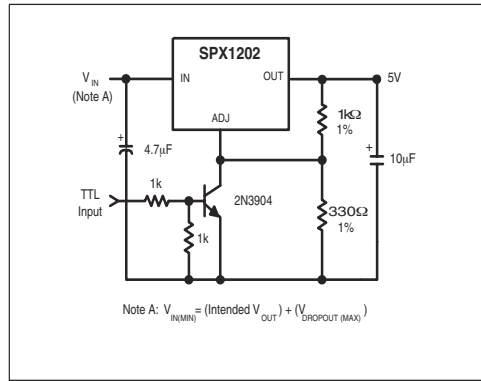

Figure 11. 5V Regulator with Shutdown

## LAYOUT CONSIDERATIONS

Parasitic line resistance can degrade load regulation. In order not to affect the behavior of the regulator, it is best to connect  $R_1$  to the case as illustrated in Figure 12. For the same reason,  $R_2$  should be connected to the negative side of the load.

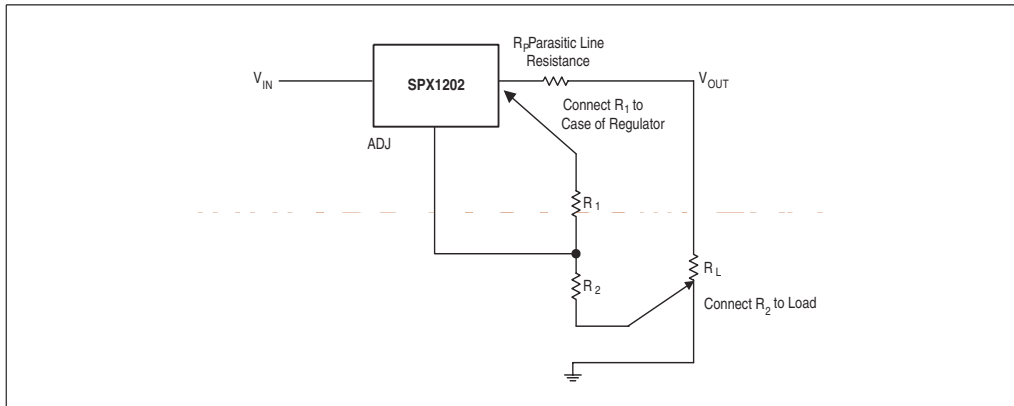
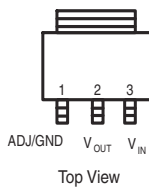

Figure 12. Recommended Connections for Best Results

## PACKAGE PINOUTS

SOT-223 (M3)



Top View

TO-252 (R)

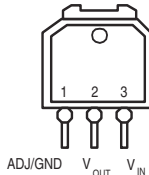

Front View

TO-220-3 (U)

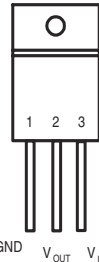

Front View

TO-263-3 (T)

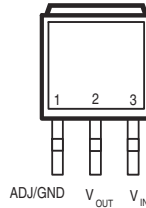

Top View



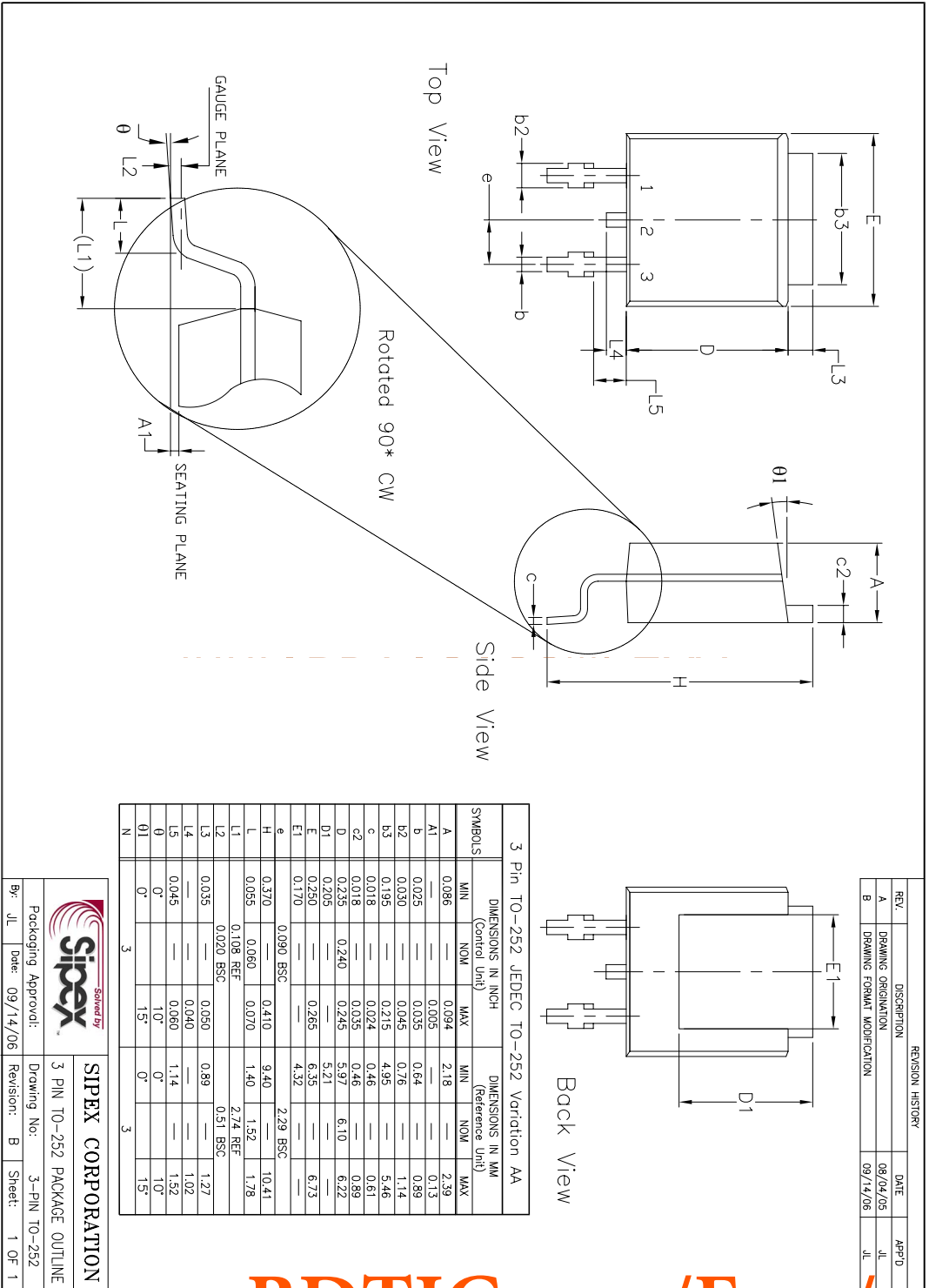



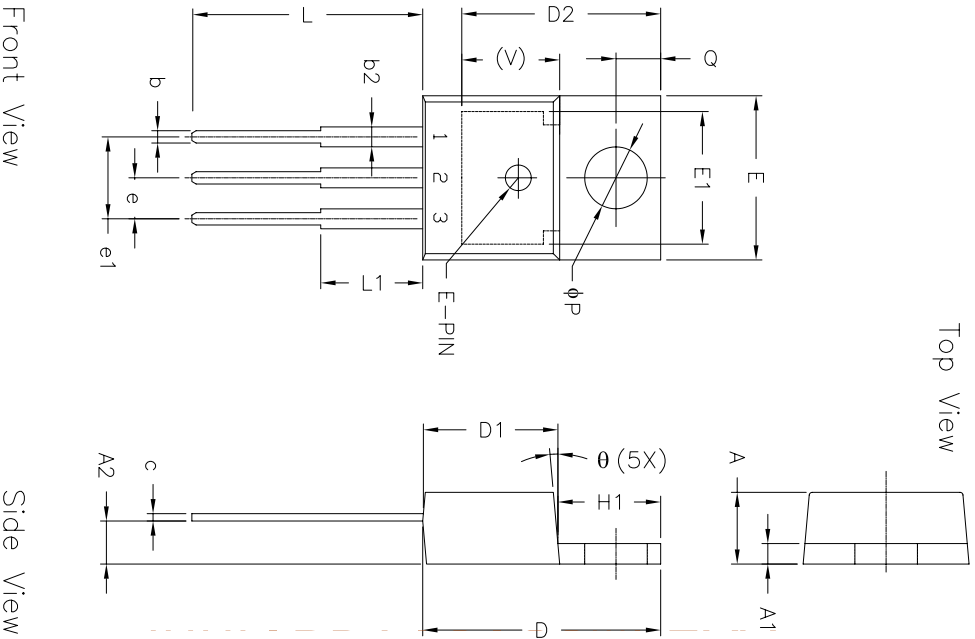

Top View

Front View

Side View

REVISION HISTORY			
REV.	DESCRIPTION	DATE	APP'D
A	DRAWING ORIGINATION	09/04/05	JL
B	DRAWING FORMAT MODIFICATION	05/25/06	JL

SYMBOLS	DIMENSIONS IN INCH (Control Unit)		DIMENSIONS IN MM (Reference Unit)	
	MIN	MAX	MIN	MAX
A	0.140	0.190	3.56	4.82
A1	0.020	0.055	0.51	1.40
A2	0.080	0.115	2.03	2.92
b	0.015	0.040	0.38	1.02
c	0.014	0.024	0.36	0.61
D	0.560	0.650	14.22	16.51
D1	0.330	0.355	8.38	9.02
D2	0.480	0.507	12.19	12.88
E	0.380	0.420	9.65	10.67
E1	0.270	0.350	6.86	8.89
e	0.100 BSC		2.54 BSC	
e1	0.200 BSC		5.08 BSC	
H1	0.230	0.270	5.84	6.86
L	0.500	0.580	12.70	14.73
L1	—	0.250	—	6.35
P	0.139	0.156	3.53	3.96
Q	0.103	0.113	2.62	2.87
V	0.240 REF		6.10 REF	
theta	3°	7°	3°	7°
N	3	3	3	3

\* Refer to product datasheet for P0D option being used

		<b>SIPEX CORPORATION</b>			
				3 PIN TO-220 PACKAGE OUTLINE	
Packaging Approval:	By: JL	Date: 05/25/06	Drawing No: 3-PIN TO-220	Revision: B	Sheet: 1 OF 2

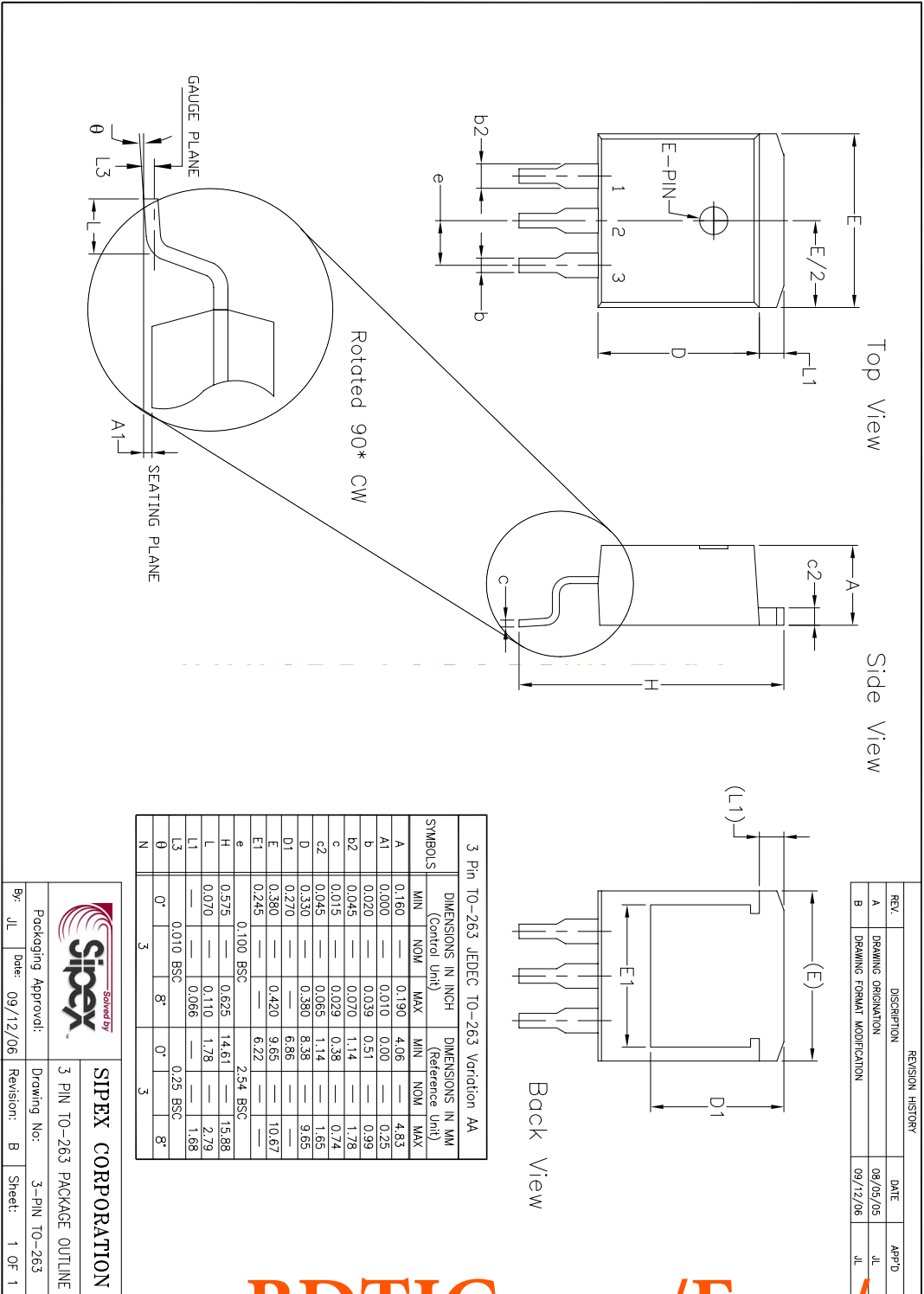

REVISION HISTORY			
REV.	DESCRIPTION	DATE	APP'D
A	DRAWING ORIGINATOR	08/05/05	JL
B	DRAWING FORMAT MODIFICATION	09/12/06	JL

SYMBOLS	DIMENSIONS IN INCH (Control Unit)		DIMENSIONS IN MM (Reference Unit)	
	MIN	MAX	MIN	MAX
A	0.160	0.190	4.06	4.83
A1	0.000	0.010	0.00	0.25
b	0.020	0.039	0.51	0.99
b2	0.045	0.070	1.14	1.78
c	0.015	0.029	0.38	0.74
c2	0.045	0.065	1.14	1.65
D	0.330	0.380	8.38	9.65
D1	0.270	—	6.86	—
E	0.380	0.420	9.65	10.67
E1	0.245	—	6.22	—
e	0.100	BSC	2.54	BSC
H	0.575	0.625	14.61	15.88
L	0.070	0.110	1.78	2.79
L1	—	0.066	—	1.68
L3	0.010	BSC	0.25	BSC
θ	0°	8°	0°	8°
N	3	—	3	—

**SIPEX CORPORATION**

3 PIN TO-263 PACKAGE OUTLINE

Solved by **Sipex**

By: JL	Date: 09/12/06	Revision: B	Sheet: 1 OF 1
Packaging Approval:		Drawing No: 3-PIN TO-263	

Part Number	Package Code	RoHS	Status	Pack Quantity
SPX1202M3	SOT-223-3		OBS	Bulk
SPX1202M3/TR	SOT-223-3		OBS	2500
SPX1202M3-2-5	SOT-223-3		OBS	Bulk
SPX1202M3-2-5/TR	SOT-223-3		OBS	2500
SPX1202M3-3-0	SOT-223-3		OBS	Bulk
SPX1202M3-3-0/TR	SOT-223-3		OBS	2500
SPX1202M3-3-3	SOT-23-3		EOL	Bulk
SPX1202M3-3-3/TR	SOT-223-3		OBS	2500
SPX1202M3-L	SOT-223-3	▪	OBS	Bulk
SPX1202M3-L/TR	SOT-223-3	▪	OBS	2500
SPX1202M3-L-2-5	SOT-223-3	▪	EOL	Bulk
SPX1202M3-L-2-5/TR	SOT-223-3	▪	OBS	2500
SPX1202M3-L-3-0	SOT-223-3	▪	OBS	Bulk
SPX1202M3-L-3-0/TR	SOT-223-3	▪	OBS	2500
SPX1202M3-L-3-3	SOT-223-3	▪	EOL	Bulk
SPX1202M3-L-3-3/TR	SOT-223-3	▪	OBS	2500
SPX1202R	TO-252		OBS	Bulk
SPX1202R/TR	TO-252		OBS	2000
SPX1202R-2-5	TO-252		OBS	Bulk
SPX1202R-2-5/TR	TO-252		OBS	2000
SPX1202R-3-0	TO-252		OBS	Bulk
SPX1202R-3-0/TR	TO-252		OBS	2000
SPX1202R-3-3	TO-252		OBS	Bulk
SPX1202R-3-3/TR	TO-252		OBS	2000
SPX1202R-L	TO-252	▪	OBS	Bulk
SPX1202R-L/TR	TO-252	▪	OBS	2000
SPX1202R-L-2-5	TO-252	▪	OBS	Bulk
SPX1202R-L-2-5/TR	TO-252	▪	OBS	2000
SPX1202R-L-3-0	TO-252	▪	OBS	Bulk
SPX1202R-L-3-0/TR	TO-252	▪	OBS	2000
SPX1202R-L-3-3	TO-252	▪	OBS	Bulk
SPX1202R-L-3-3/TR	TO-252	▪	OBS	2000

Part Number	Package Code	RoHS	Status	Pack Quantity
SPX1202T	TO-263-3		OBS	Bulk
SPX1202T/TR	TO-263-3		OBS	2000
SPX1202T-2-5	TO-263-3		OBS	Bulk
SPX1202T-2-5/TR	TO-263-3		OBS	500
SPX1202T-3-0	TO-263-3		OBS	Bulk
SPX1202T-3-0/TR	TO-263-3		OBS	500
SPX1202T-3-3	TO-263-3		EOL	Bulk
SPX1202T-3-3/TR	TO-263-3		OBS	500
SPX1202T-L	TO-263-3	▪	OBS	Bulk
SPX1202T-L/TR	TO-263-3	▪	OBS	500
SPX1202T-L-2-5	TO-263-3	▪	OBS	Bulk
SPX1202T-L-2-5/TR	TO-263-3	▪	OBS	500
SPX1202T-L-3-0	TO-263-3	▪	OBS	Bulk
SPX1202T-L-3-0/TR	TO-263-3	▪	OBS	500
SPX1202T-L-3-3	TO-263-3	▪	OBS	Bulk
SPX1202T-L-3-3/TR	TO-263-3	▪	OBS	500
SPX1202U	TO-220-3		EOL	Bulk
SPX1202U-2-5	TO-220-3		OBS	Bulk
SPX1202U-3-0	TO-220-3		OBS	Bulk
SPX1202U-3-3	TO-220-3		EOL	Bulk
SPX1202U-L	TO-220-3	▪	OBS	Bulk
SPX1202U-L-2-5	TO-220-3	▪	OBS	Bulk
SPX1202U-L-3-0	TO-220-3	▪	OBS	Bulk
SPX1202U-L-3-3	TO-220-3	▪	OBS	Bulk



Sipex Corporation

**Headquarters and Sales Office**

233 South Hillview Drive  
 Milpitas, CA 95035  
 TEL: (408) 934-7500  
 FAX: (408) 935-7600

Solved by Sipex™

Sipex Corporation reserves the right to make changes to any products described herein. Sipex does not assume any liability arising out of the application, or use, or in any product or circuit described herein; neither does it convey any license under its patents, or the rights of others.

[www.BDTC.com/Exar/](http://www.BDTC.com/Exar/)