

5A Low Dropout Voltage Regulator

Adjustable & Fixed Output, Fast Response Time

FEATURES

- Adjustable Output Down to 1.25V
- 1% Output Accuracy
- Output Current of 5A
- Low Dropout Voltage: 370mV @ 5A
- Tight Line Regulation: 0.06%
- Load Regulation: 0.2%
- Fast Transient Response
- Reverse-Battery Protection
- Current Limit and Thermal Protection

APPLICATIONS

- Powering VGA & Sound Card
- Power PC™ Supplies
- SMPS Post Regulator
- High Efficiency “Green” Computer Systems
- High Efficiency Linear Power Supplies
- Constant Current Regulators
- Adjustable Power Supplies
- Battery Charger

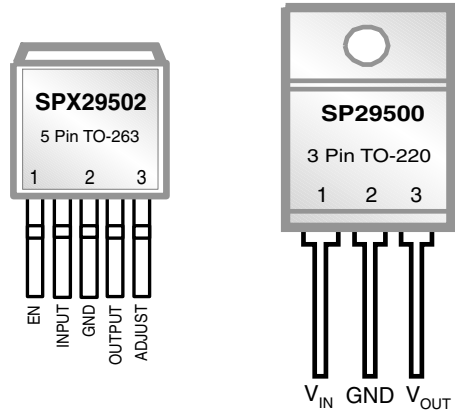

Now Available in Lead Free Packaging

DESCRIPTION

The SPX29500/01/02/03 are 5A highly accurate voltage regulators with a low dropout voltage of 370mV @ 5A. These regulators are specifically designed for low voltage applications that require a low dropout voltage and a fast transient response. They are fully fault protected against over-current, reverse battery, and positive and negative voltage transients. On-Chip trimming adjusts the reference voltage to 1% initial accuracy. Other features in the 5 pin versions include Enable, and Error Flag.

The SPX29500/01/02/03 are offered in 3 & 5-pin TO-220 & TO-263 packages. For a 1.5A version, refer to the SPX29150 data sheet. For a 3A version, refer to the SPX29300 datasheet.

TYPICAL APPLICATION CIRCUITS

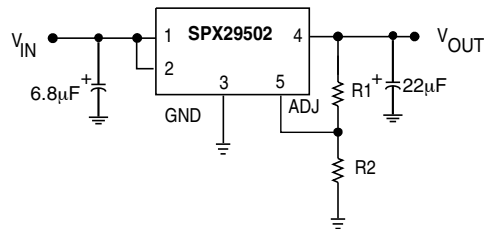
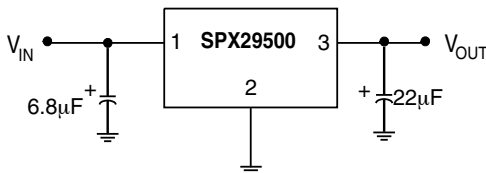

Figure 1. Fixed Output Linear Regulator

Figure 2. Adjustable Output Linear Regulator

ABSOLUTE MAXIMUM RATINGS

Lead Temperature (soldering, 5 seconds)260°C
Storage Temperature Range-65°C to +150°C
Operating Junction Temperature Range-40°C to +125°C
Input Voltage (Note 1) 20V

OPERATING RATINGS

Input Voltage 16V
---------------	-----------

ELECTRICAL CHARACTERISTICS

Specifications are at $V_{IN} = V_{OUT} + 1V$ and $I_{OUT} = 10mA$, $C_{IN} = 6.8\mu F$, $C_{OUT} = 22\mu F$, $T_A = 25^\circ C$, unless otherwise specified. The \blacklozenge denotes the specifications which apply over the full operating temperature range, unless otherwise specified.

PARAMETER	MIN	TYP	MAX	UNITS	CONDITIONS
Fixed Voltage Options SPX29500/01					
1.8V Version					
Output Voltage	1.782 1.764	1.800 1.800	1.818 1.836	V	$I_{OUT} = 10mA$ \blacklozenge $10mA \leq I_{OUT} \leq 5A$, $2.8V \leq V_{IN} \leq 16V$
2.5V Version					
Output Voltage	2.475 2.450	2.500 2.500	2.525 2.550	V	$I_{OUT} = 10mA$ \blacklozenge $10mA \leq I_{OUT} \leq 5A$, $3.5V \leq V_{IN} \leq 16V$
3.3V Version					
Output Voltage	3.267 3.234	3.300 3.300	3.333 3.366	V	$I_{OUT} = 10mA$ \blacklozenge $10mA \leq I_{OUT} \leq 5A$, $4.3V \leq V_{IN} \leq 16V$
5.0V Version					
Output Voltage	4.950 4.900	5.000 5.000	5.050 5.100	V	$I_{OUT} = 10mA$ \blacklozenge $10mA \leq I_{OUT} \leq 5A$, $6.0V \leq V_{IN} \leq 16V$
All Voltage Options SPX29500/01/02/03					
Line Regulation		0.06	0.5	%	$I_{OUT}=10mA$, $(V_{OUT}+1V) \leq V_{IN} \leq 16V$
Load Regulation		0.2	1	%	$V_{IN}=V_{OUT}+2V$, $10mA \leq I_{OUT} \leq I_{FL}$ (Note 2)
$\Delta V/\Delta T$		20	100	ppm/°C	\blacklozenge V_{OUT} Temp Coefficient (Note 5)
Dropout Voltage, except 1.8V		80 200 370	250 600	mV	\blacklozenge $I_{OUT}=250mA$ \blacklozenge $I_{OUT}=2.5A$ \blacklozenge $I_{OUT}=5A$
Ground Current (Note 4)		20 70	50	mA	\blacklozenge $I_{OUT}=2.5A$ \blacklozenge $I_{OUT}=5A$
Ground Pin Current at Dropout		3		mA	$V_{IN}=0.5V$ less than specified V_{OUT} , $I_{OUT}=10mA$
Current Limit		7.5	10	A	\blacklozenge (Note 3)
Output Noise Voltage (10Hz to 100kHz) $I_L=100mA$		425 350		μV_{RMS}	$C_L=22\mu F$ $C_L=33\mu F$
Reference Voltage	1.228 1.215	1.240	1.252 1.265	V	Adjustable version only \blacklozenge
Reference Voltage	1.203		1.277	V	Adjustable version only (Note 7)
Adjust Pin Bias Current		40	80 120	nA	\blacklozenge
Reference Voltage Temp. Coeff.		20		ppm/°C	(Note 6)
Adjust Pin Bias Current Temp. Coeff.		0.1		nA/°C	

ELECTRICAL CHARACTERISTICS: Continued

Specifications are at $V_{IN} = V_{OUT} + 1V$ and $I_{OUT} = 10mA$, $C_{IN} = 6.8\mu F$, $C_{OUT} = 22\mu F$, $T_A = 25^\circ C$, unless otherwise specified. The \blacklozenge denotes the specifications which apply over the full operating temperature range, unless otherwise specified.

PARAMETER	MIN	TYP	MAX	UNITS		CONDITIONS
Flag Output (Error Comparator) SPX29501/03						
Output Leakage Current		0.01	1 2	μA	\blacklozenge	$V_{OH}=16V$
Output Low Voltage		220	300 400	mV	\blacklozenge	Device set for 5V, $V_{IN}=4.5V$, $I_{OL}=250\mu A$
Upper Threshold Voltage	40 25	60		mV	\blacklozenge	Device set for 5V, (Note 8)
Lower Threshold Voltage		75	95 140	mV	\blacklozenge	Device set for 5V, (Note 8)
Hysteresis		15		mV		Device set for 5V, (Note 8)
Enable Input SPX29501/02						
Input Logic Voltage Low (OFF) High (ON)	2.4		0.8	V		(Note 10)
ENABLE Input Current		100	600 750	μA	\blacklozenge	$V_{EN}=16V$
		0.6	2 4	μA	\blacklozenge	$V_{EN}=0.8V$
Regulator Output Current in Shutdown		10	500	μA	\blacklozenge	(Note 9)
Thermal Resistance		2		$^\circ C/W$		TO-220 Junction to Case, at Tab
		60				TO-220 Junction to Ambient
		2				TO-263 Junction to Case, at Tab
		60				TO-263 Junction to Ambient

NOTES:

Note 1: Maximum positive supply voltage of 20V must be of limited duration (<100ms) and duty cycle of less than 1%. The maximum continuous supply voltage is 16V.

Note 2: Full load current (I_{FL}) is defined as 5A.

Note 3: $V_{IN} = V_{OUT (NOMINAL)} + 1V$. For example, use $V_{IN} = 4.3V$ for a 3.3V regulator. Employ pulse-testing procedures to minimize temperature rise.

Note 4: Ground pin current is the regulator quiescent current. The total current drawn from the source is the sum of the load current plus the ground pin current.

Note 5: Output voltage temperature coefficient is defined as the worst case voltage change divided by the total temperature range.

Note 6: Thermal regulation is defined as the change in output voltage at time T after a change in power dissipation is applied, excluding load / line regulation effects. Specifications for a 200mA load pulse as $V_{IN} = 20V$ (a 4W pulse) for $t = 10ms$.

Note 7: $V_{REF} \leq V_{OUT} \leq (V_{IN}-1)$, $2.3V \leq V_{IN} \leq 16V$, $10mA \leq I_L \leq I_{FL}$, $T_J < T_{Jmax}$.

Note 8: Comparator threshold is expressed in terms of a voltage differential at the Adjust terminal below the nominal reference voltage measured 6V input. To express these thresholds in terms of output voltage change, multiply the error amplifier gain = $V_{OUT}/V_{REF} = (R1 + R2)/R2$. For example, at a programmable output voltage of 5V, the Error output is guaranteed to go low when the output drops by $95mV \times 5V / 1.240V = 383mV$. Threshold remain constant as a percent of V_{OUT} as V_{OUT} is varied, with the dropout warning occurring at typically 5% below nominal, 7.7% guaranteed.

Note 9: $V_{EN} \leq 0.4V$ and $V_{IN} \leq 16V$, $V_{OUT} = 0$.

Note 10: Measured with $I_{OUT} = I_{OUT MIN}$ (10mA).

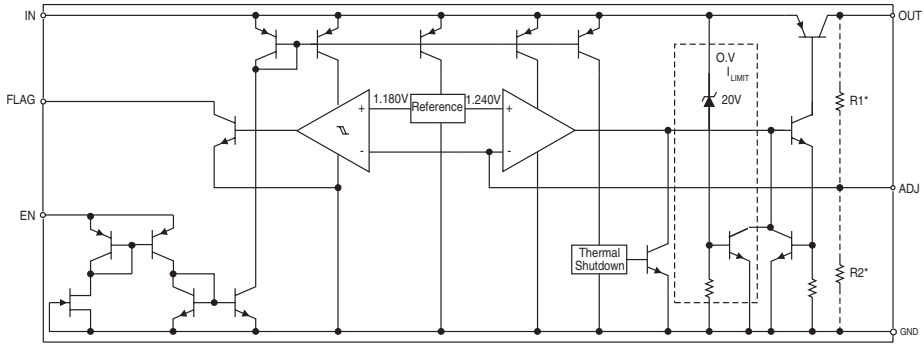

TYPICAL PERFORMANCE CHARACTERISTICS

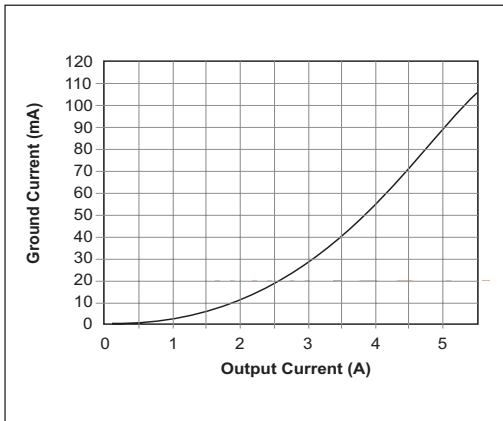

Figure 3. Ground Current (mA) vs. Output Current (A)

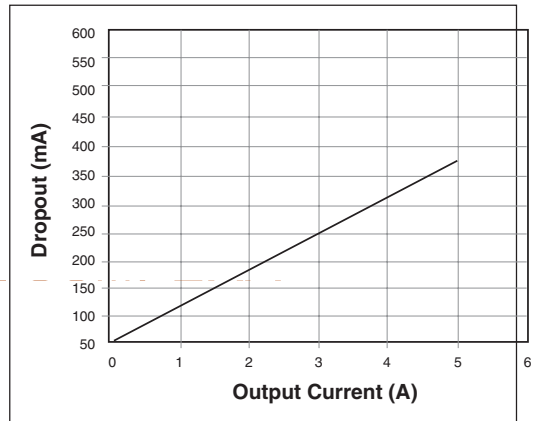

Figure 4. Dropout (mV) vs. Output Current (A)

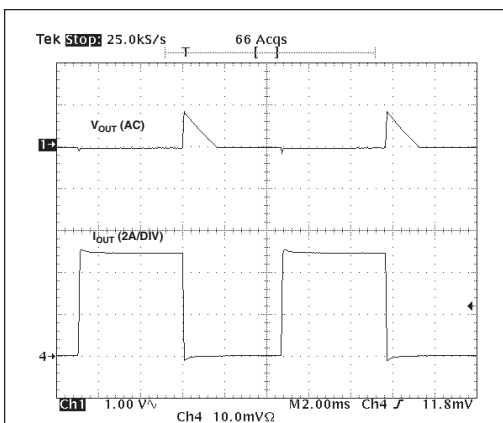

Figure 5. Load Transient ($V_{IN}=4V$, $V_O=3.3V$, $C_{OUT}=22\mu F$, $10mA \sim 5A$)

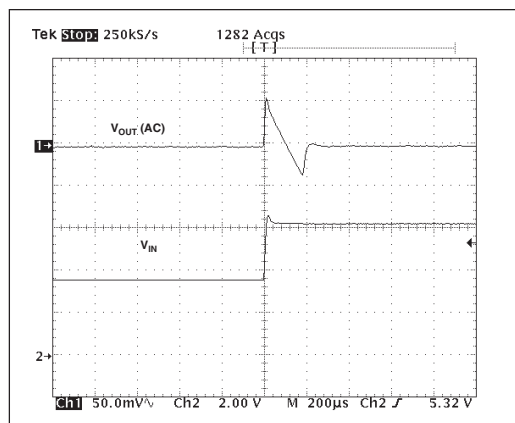

Figure 6. Line Transient ($C_{OUT}=22\mu F$, $I_O=10mA$)

The SPX29500/01/02/03 incorporates protection against over-current faults, reversed load insertion, over temperature operation, and positive and negative transient voltage.

Thermal Considerations

Although the SPX29500/01/02/03 offers limiting circuitry for overload conditions, it is still necessary to insure that the maximum junction temperature is not exceeded in the application. Heat will flow through the lowest resistance path, the junction-to-case path. In order to insure the best thermal flow of the component, proper mounting is required.

TO-220 Design Example:

Assume that $V_{IN} = 8V$, $V_{OUT} = 5V$, $I_{OUT} = 5A$, $T_A = 50^\circ C$, $\theta_{HA} = 1^\circ C/W$, $\theta_{CH} = 2^\circ C/W$, and $\theta_{JC} = 2^\circ C/W$, where:

T_A = ambient temperature,
 θ_{HA} = heatsink to ambient thermal resistance
 θ_{CH} = case to heatsink thermal resistance
 θ_{JC} = junction to case thermal resistance

The power calculated under these conditions is:

$$P_D = (V_{IN} - V_{OUT}) * I_{OUT} = 15W.$$

And the junction temperature is calculated as

$$T_J = T_A + P_D * (\theta_{HA} + \theta_{CH} + \theta_{JC}) \text{ or}$$

$$T_J = 50 + 15 * (1+2+2) = 125^\circ C$$

Reliable operation is insured.

Capacitor Requirements

The output capacitor is needed to insure stability and minimize the output noise. The value of the capacitor varies with the load. However, a minimum value of 22 μ F aluminum capacitor will guarantee stability over all load conditions. A tantalum capacitor is recommended if a faster

load transient response is needed. If the power source has a high AC impedance, a 0.1 μ F ceramic capacitor between input & ground is recommended.

Minimum Load Current

To ensure a proper behavior of the regulator under light load, a minimum load of 10mA for SPX29500/01/02/03 is required.

Adjustable Regulator Design

The SPX29502/03 are adjustable regulators that can be programmed to any value between 1.24V and 16V using 2 resistors, R1 and R2. The relationship between the resistors is:

$$R1 = R2(V_{OUT}/1.24-1).$$

Error Flag

The SPX29501/03 features an error flag that indicates either an over current or under voltage condition. The flag output goes low, sinking 10mA when either condition occurs.

Enable Input

The SPX29501/02 have an Enable function that switches the regulator on and off. Their thresholds are TTL compatible. Enabling the regulator requires approximately 20 μ A of current.

Typical Application Circuits

Figure 1 represents a typical fixed output regulator. Figure 2 represents an adjustable output regulator. The values of R1 and R2 set the output voltage value as follows:

$$V_{OUT} = V_{REF} * [1 + (R1/R2)].$$

For best results, the total series resistance should guarantee a minimum regulator load current of 10mA.

TO-263-3 Package (T)

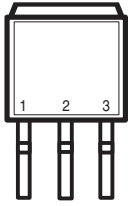

V_{IN} GND V_{OUT}
Front View

TO-263-5 Package (T5)

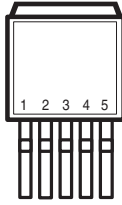

Top View

SPX29500
1) V_{IN}
2) GND
3) V_{OUT}

SPX29501
1) ENABLE
2) INPUT
3) GND
4) OUTPUT
5) FLAG

SPX29502
1) ENABLE
2) INPUT
3) GND
4) OUTPUT
5) ADJUST

SPX29503
1) FLAG
2) INPUT
3) GND
4) OUTPUT
5) ADJUST

TO-220-3 Package (U)

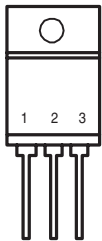

GND
 V_{IN} V_{OUT}
Front View

TO-220-5 Package (U5)

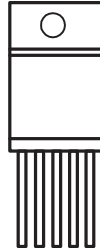

1 2 3 4 5
Top View

SPX29500
1) V_{IN}
2) GND
3) V_{OUT}

SPX29501
1) ENABLE
2) INPUT
3) GND
4) OUTPUT
5) FLAG

SPX29502
1) ENABLE
2) INPUT
3) GND
4) OUTPUT
5) ADJUST

SPX29503
1) FLAG
2) INPUT
3) GND
4) OUTPUT
5) ADJUST

*Tab is internally connected to GND

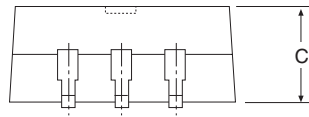
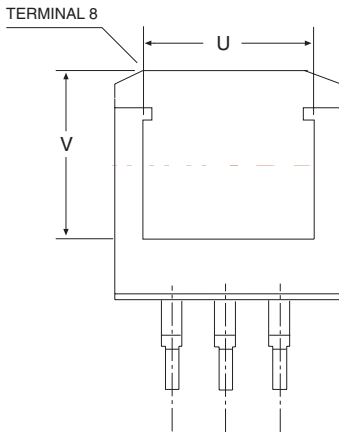
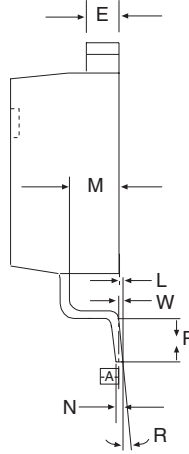
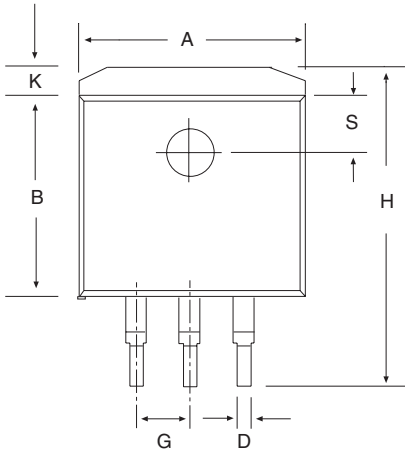

DIMENSIONS in inches		
SYMBOL	MIN	MAX
A	.396	0.406
B	0.326	0.336
C	0.170	0.180
D	0.026	0.036
E	0.045	0.055
G	0.100 REF	0.100 REF
H	0.580	0.620
K	0.055	0.066
L	.000	.010
M	0.098	0.108
N	.017	.023
P	.090	.110
R	0°	8°
S	.095	.105
U	.30 REF	.30 REF
V	.305 REF	.305 REF
W	.010	.010

3 Pin TO-263

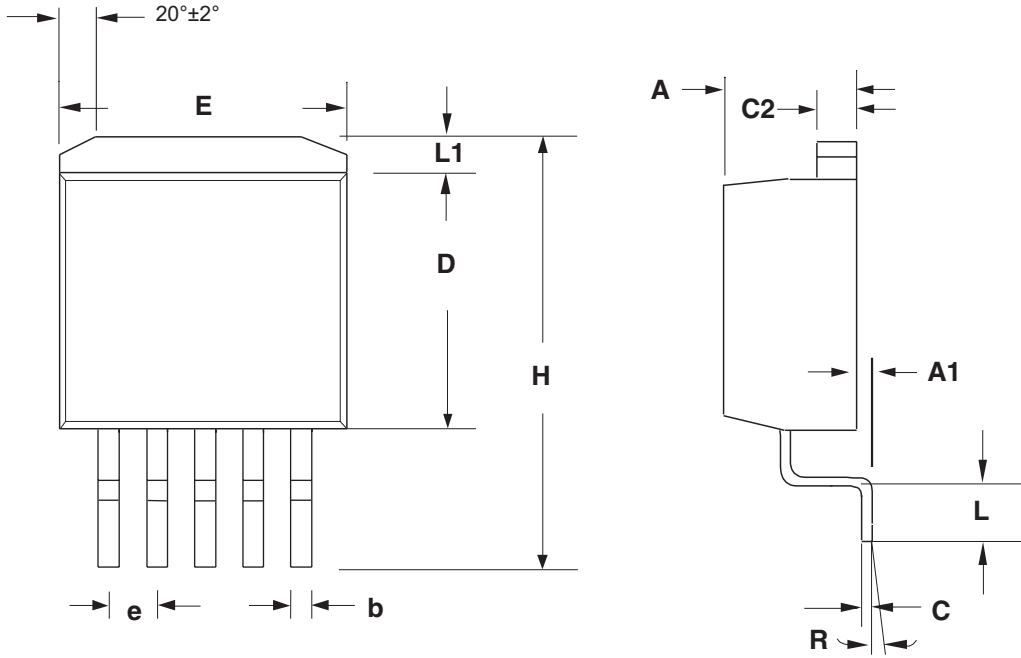

DIMENSIONS in inches		
SYMBOL	MIN	MAX
E	.380	0.420
D	0.330	0.380
A	0.160	0.190
b	0.020	0.039
C2	0.045	0.065
e	0.067 REF	0.067 REF
H	0.575	0.625
L1	0.055	0.066
C	.015	.029
L	0.090	0.110
A1	.000	.010
R	0°	8°

5 Pin TO-263

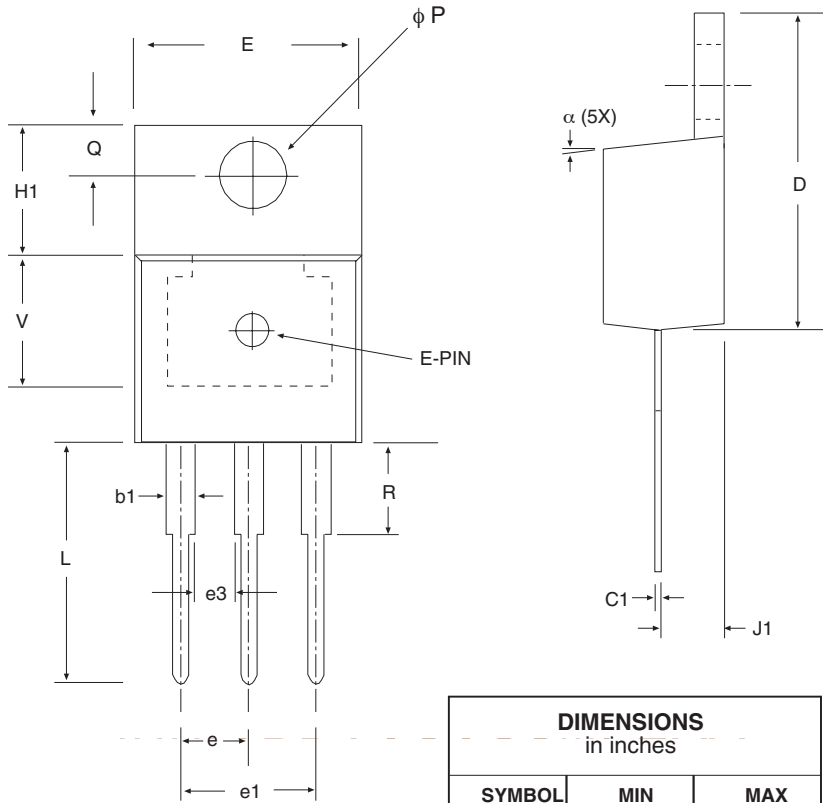

DIMENSIONS in inches		
SYMBOL	MIN	MAX
A	0.160	0.190
b	0.025	0.040
C1	0.015	0.022
D	0.560	0.590
E	0.385	0.415
e	0.090	0.110
e1	0.190	0.210
e3	0.045	0.055
F	0.045	0.055
H1	0.234	0.258
J1	0.090	0.115
ϕP	0.146	0.156
Q	0.103	0.113
L	0.540	0.560
α	3° typ	7° typ
b1	0.450	0.060
R	0.243 REF	6.170 REF
U	0.300 REF	7.620 REF
V	0.240 REF	6.100 REF

3 Pin TO-220

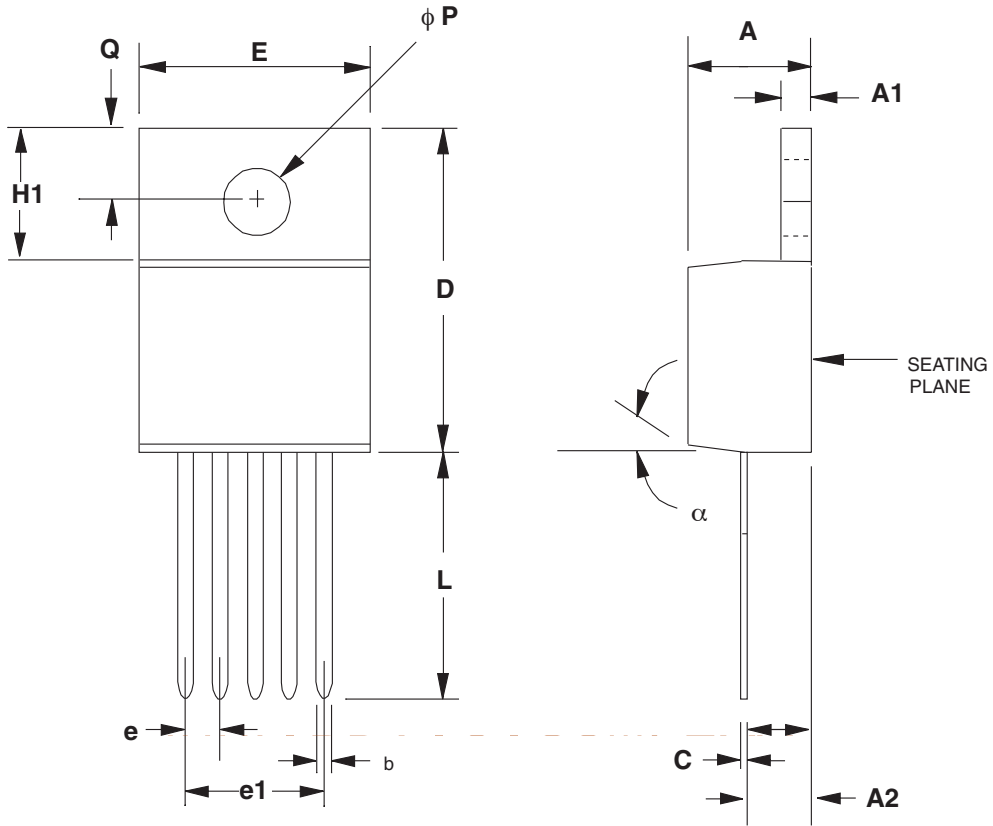

DIMENSIONS in inches		
SYMBOL	MIN	MAX
A	0.165	0.19
A1	0.045	0.055
A2	0.09	0.115
C	0.012	0.025
D	0.560	0.596
e	0.067 BSC	0.067 BSC
e1	0.268 REF	0.268 REF
E	0.385	0.415
H1	0.224	0.258
b	0.025	0.04
ϕP	0.146	0.156
Q	0.103	0.113
L	0.54	0.56
α	7° typ	7° typ

5 Pin TO-220

ORDERING INFORMATION

PART NUMBER	ACCURACY	OUTPUT VOLTAGE	PACKAGE
SPX29500U-1.8	1.0%	1.8V	3 lead TO-220
SPX29500U-2.5	1.0%	2.5V	3 lead TO-220
SPX29500U-3.3	1.0%	3.3V	3 lead TO-220
SPX29500U-5.0	1.0%	5.0V	3 lead TO-220
SPX29500T-1.8	1.0%	1.8V	3 lead TO-263
SPX29500T-2.5	1.0%	2.5V	3 lead TO-263
SPX29500T-3.3	1.0%	3.3V	3 lead TO-263
SPX29500T-5.0	1.0%	5.0V	3 lead TO-263
SPX29501U5-1.8	1.0%	1.8V	5 lead TO-220
SPX29501U5-2.5	1.0%	2.5V	5 lead TO-220
SPX29501U5-3.3	1.0%	3.3V	5 lead TO-220
SPX29501U5-5.0	1.0%	5.0V	5 lead TO-220
SPX29501T5-1.8	1.0%	1.8V	5 lead TO-263
SPX29501T5-2.5	1.0%	2.5V	5 lead TO-263
SPX29501T5-3.3	1.0%	3.3V	5 lead TO-263
SPX29501T5-5.0	1.0%	5.0V	5 lead TO-263
SPX29502T5	1.0%	Adj	5 lead TO-263
SPX29502U5	1.0%	Adj	5 lead TO-220
SPX29503T5	1.0%	Adj	5 lead TO-263
SPX29503U5	1.0%	Adj	5 lead TO-220

Please consult the factory for pricing and availability on a Tape-On-Reel option.

Available in lead free packaging. To order, add "-L" suffix to the part number.
Example: SPX29500U-1.8 = standard; SPX29500U-L -1.8 = lead free.



ANALOG EXCELLENCE

Sipex Corporation

Headquarters and Sales Office

233 South Hillview Drive
Milpitas, CA 95035
TEL: (408) 934-7500
FAX: (408) 935-7600

Sales Office

22 Linnell Circle
Billerica, MA 01821
TEL: (978) 667-8700
FAX: (978) 670-9001
e-mail: sales@sipex.com

Sipex Corporation reserves the right to make changes to any products described herein. Sipex does not assume any liability arising out of the application or use of any product or circuit described herein; neither does it convey any license under its patent rights nor the rights of others.

www.BDTIC.com/Exar/