

## 300mA Low Dropout Voltage Regulator

### FEATURES

- 3.3V and 3.5V Versions
- Input-Output Differential is 0.35V at 200mA
- Input-Output Differential is 0.45V at 300mA
- Mirror-Image Insertion Protection
- Internal Thermal Protection
- Available in SOT-223 and SOT-89 Packages
- Short Circuit Protection
- 2% Output Accuracy, SPX2808A

### APPLICATIONS

- CD-ROMs
- Scanners
- Radio Control Systems

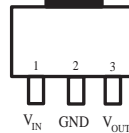
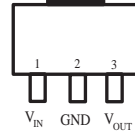
**SOT-89 (M1)**

**SOT-223 (M3)**

**Top View**

*Now Available in Lead Free Packaging*

- Portable Instrumentation
- Cordless Telephones
- USBs
- Toys

### DESCRIPTION

The SPX2808 is a low power, positive voltage regulator. This device is an excellent choice for use in battery-powered applications such as cordless telephones, radio control systems, and portable computers. The SPX2808 features offers very low quiescent currents (0.4mA), and very low drop output voltage (50mV at light load and 450mV at 300mA). The SPX2808 is offered in a 3-pin SOT-223 and SOT-89 package.

### TYPICAL APPLICATIONS CIRCUIT

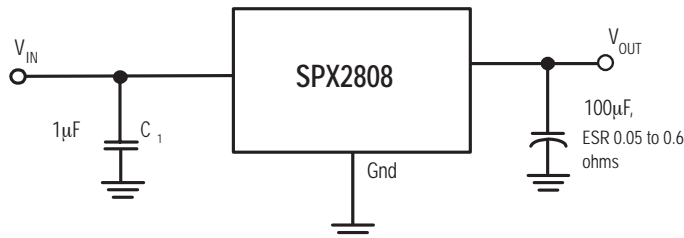

**ABSOLUTE MAXIMUM RATINGS**

Power Dissipation (note 3) .....	Internally limited
Lead Temp (soldering, 5 seconds) .....	260°C
Storage Temperature Range .....	-65°C to +150°C
Input Supply Voltage Range .....	-0.3V to +30V
ESD Rating (note 4) .....	2kV

**RECOMMENDED OPERATING CONDITIONS**

Input Supply Voltage Range .....	3.0V to 26V
Operating Junction Temperature Range .....	-40°C to 85°C
SOT-89 $\Theta_{JA}$ .....	90°C/W
SOT-223 .....	60°C/W

**ELECTRICAL CHARACTERISTICS**

at  $T_A=25^\circ\text{C}$ , unless otherwise specified. (Note 1)

PARAMETER	CONDITIONS	Min	Typ	Max	Min	Typ	Max	Units
<b>3.3V Version</b>		<b>SP2808A</b>			<b>SP2808</b>			
Quiescent Current ( $I_Q$ )	$I_{OUT} = 0\text{mA}$ , Except $I_{CONT}$		100	200		100	200	$\mu\text{A}$
Output Voltage ( $V_{OUT}$ )	$I_{OUT} = 50\text{mA}$ , Except $I_{CONT}$ $V_{IN} = 8\text{V}$ , at Output Off	3.24	3.3	3.36	3.20	3.3	3.40	V
Line Regulation	$I_{OUT} = 40\text{mA}$ , $5 \leq V_{IN} \leq 10\text{V}$		0.3	0.4		0.3	0.4	%/V
Load Regulation	$I_{OUT} = 1\text{mA} \rightarrow 60\text{mA}$ $I_{OUT} = 1\text{mA} \rightarrow 100\text{mA}$		10	40		10	40	mV
			30	80		30	80	mV
Dropout Voltage ( $V_{DROP}$ )	$I_{OUT} = 60\text{mA}$ $I_{OUT} = 200\text{mA}$ $I_{OUT} = 300\text{mA}$		0.2	0.3		0.2	0.3	V
			0.35	0.7		0.35	0.7	V
			0.45			0.45		V
Continuous Output Current ( $I_{OUT}$ )	$I_{OUT}$ when $V_{OUT}$ drops 0.3V from $V_O$ (typ)(Note 3)		400			400		mA
Temperature Coefficient			100			100		ppm/°C
Pulse Output Current	5 ms pulse, 12.5% duty cycle			300			300	mA
<b>3.5V Version</b>								
Quiescent Current ( $I_Q$ )	$I_{OUT} = 0\text{mA}$ , Except $I_{CONT}$		100	200		100	200	$\mu\text{A}$
Output Voltage ( $V_{OUT}$ )	$I_{OUT} = 50\text{mA}$ , Except $I_{CONT}$ $V_{IN} = 8\text{V}$ , at Output Off	3.43	3.5	3.57	3.40	3.5	3.60	V
Line Regulation	$I_{OUT} = 40\text{mA}$ , $5 \leq V_{IN} \leq 10\text{V}$		0.3	0.4		0.3	0.4	%/V
Load Regulation	$I_{OUT} = 1\text{mA} \rightarrow 60\text{mA}$ $I_{OUT} = 1\text{mA} \rightarrow 100\text{mA}$		10	40		10	40	mV
			30	80		30	80	mV
Dropout Voltage ( $V_{DROP}$ )	$I_{OUT} = 60\text{mA}$ $I_{OUT} = 200\text{mA}$ $I_{OUT} = 300\text{mA}$		0.2	0.3		0.2	0.3	V
			0.35	0.7		0.35	0.7	V
			0.45			0.45		V
Continuous Output Current ( $I_{OUT}$ )	$I_{OUT}$ when $V_{OUT}$ drops 0.3V from $V_O$ (typ)(Note 3)		400			400		mA
Temperature Coefficient			100			100		ppm/°C
Pulse Output Current	5 ms pulse, 12.5% duty cycle			300			300	mA

**NOTES:**

Note 1: When mounted as recommended. Derate 11mW/°C for SOT-89 packages when ambient temperatures are over 25°C.

Note 2: See TYPICAL APPLICATIONS notes to ensure constant junction temperature, low duty cycle pulse testing used.

Note 3: All limits are at 25°C; Boldface limits are over the full operating junction temperature range of -40°C to +85°C.

Note 4: The maximum power dissipation is a function of maximum junction temperature, total thermal resistance, and ambient temperature.

Note 5: Human body model, 100pF discharged through 1.5k $\Omega$ .

## TYPICAL PERFORMANCE CHARACTERISTICS

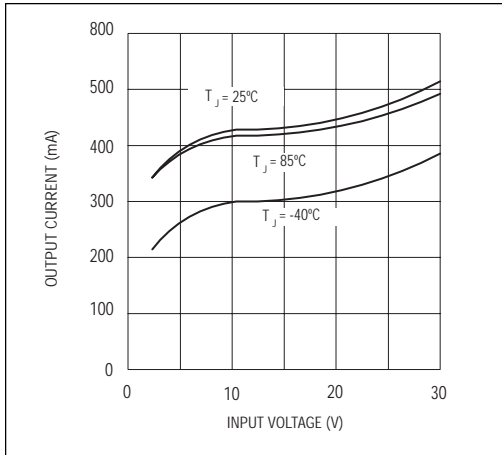

Figure 1. Peak Output Current

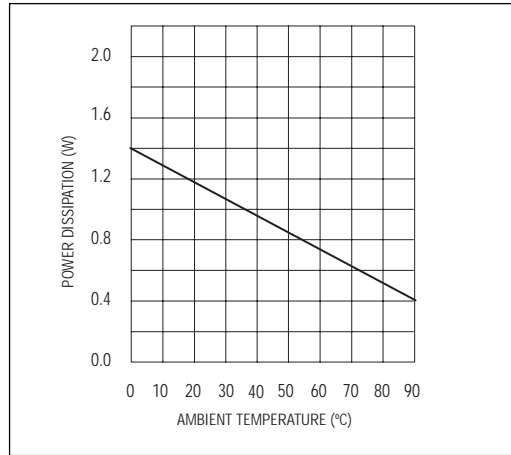

Figure 2. Minimum Power Dissipation (SOT-89)

## APPLICATION INFORMATION

The SPX2808 requires an output capacitor for device stability. The value required varies greatly depending upon the application circuit and other factors. The high frequency characteristics of electrolytic capacitors depend greatly on the type and also on the manufacturer. Sometimes only bench testing is the only means to determine the proper capacitor type and value. The high quality 100 $\mu\text{F}$  aluminum electrolytic covers all general application circuits, this stability can be obtained with a tantalum electrolytic value of 47 $\mu\text{F}$ .

Another critical point of electrolytic characteristics is its performance over temperature. The SPX2808 is designed to operate starting at  $-40^\circ\text{C}$  which may not be true in the case of electrolytic. Higher temperatures generally no problem. The electrolytic type in aluminum will freeze around  $-30^\circ\text{C}$ . This could cause an oscillation at output of regulator. At a lower temperature requirement by many applications the capacitor should maintain its performance. So as a result, for an application which regulator

junction temperature does not exceed  $25^\circ\text{C}$ , the output capacitor can be reduced by the factor of two over the value needed for the entire temperature range.

In most applications the SPX2808 is operating at few milliamps. In these applications the output capacitance can be further reduced. For example, when the regulator is running at 10mA output current the output capacitance value is half compared to the same regulator that is running at 100mA. The value decreases with higher output voltages, since the internal loop gain is reduced.

The worst case occurs at the lower temperature and maximum operating currents, the entire circuit and the electrolytic, should be cooled down to the minimum temperature. The minimum of 0.6 volts required at the input of regulator above the output to keep the power dissipation and die heating to its minimum. After the value for the capacitor has been determined for actual use, the value should be doubled.

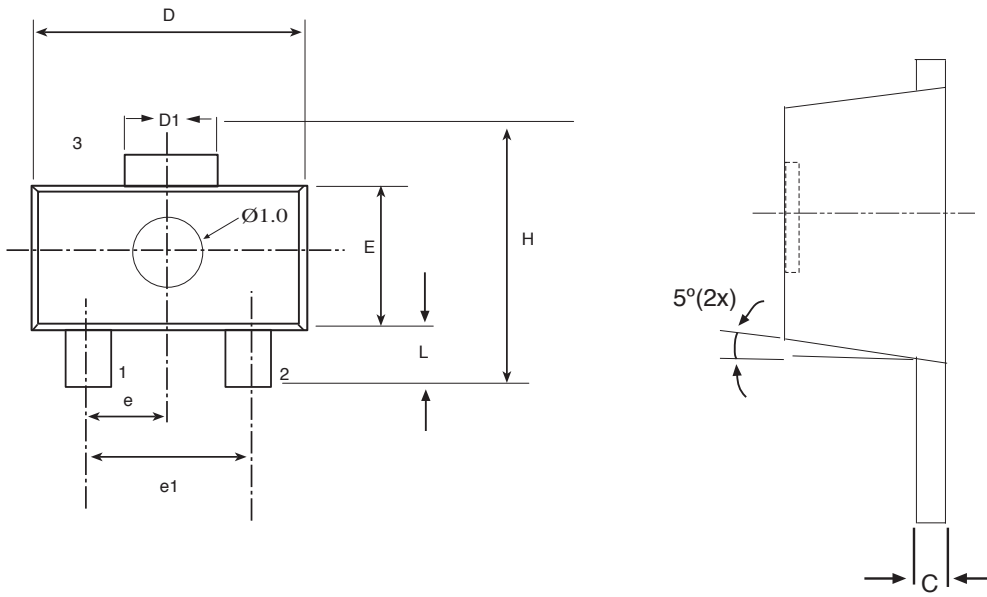

3 PIN SOT-89	Dimensions in (mm)		
	MIN	NOM	MAX
A	1.40	1.50	1.60
b	0.36	0.42	0.48
L	0.80	-	1.20
b1	0.41	0.47	0.53
C	0.38	0.40	0.43
D	4.40	4.50	4.60
D1	1.40	1.60	1.75
H	3.94	-	4.25
E	2.40	2.50	2.60
e	1.45	1.50	1.55
e1	2.90	3.00	3.10

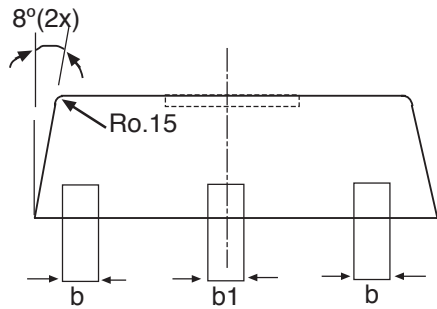

3 PIN SOT-89

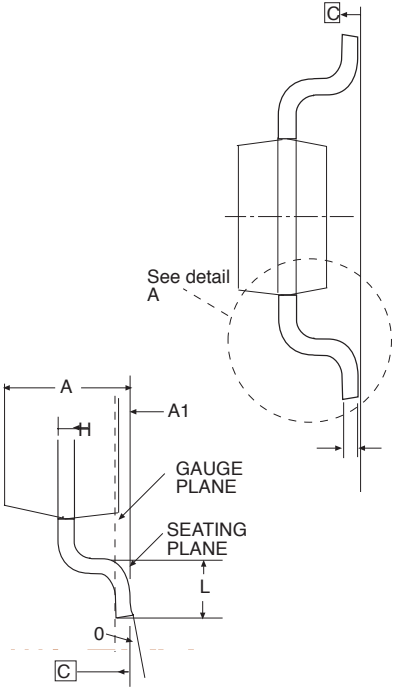
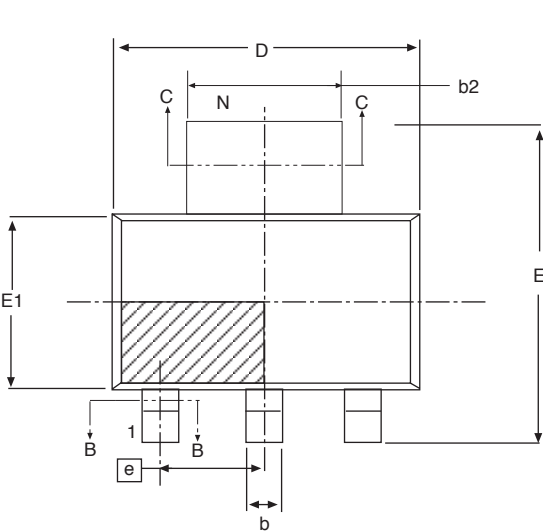

3 PIN SOT-223 JEDEC TO-261 (AA) Variation	Dimensions in (mm)		
	MIN	NOM	MAX
A	-	-	1.80
A1	0.02	-	0.10
A2	1.50	1.60	1.70
b	0.66	0.76	0.84
b2	2.90	3.00	3.10
c	0.23	0.30	0.35
D	6.30	6.50	6.70
E	6.70	7.00	7.30
E1	3.30	3.50	3.70
e	2.30 BASIC		
e1	4.60 BASIC		
L	0.75	-	-
φ	0°	-	10°

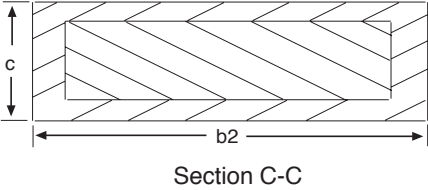
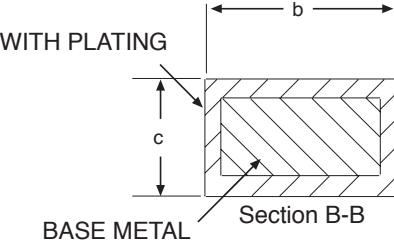

**3 PIN SOT-223**

---

**ORDERING INFORMATION**

<b>PART NUMBER</b>	<b>ACCURACY</b>	<b>OUTPUT VOLTAGE</b>	<b>PACKAGE</b>
SPX2808AM1-3.3	2%	3.3V	3 lead SOT-89
SPX2808AM1-3.3/TR	2%	3.3V	3 lead SOT-89
SPX2808AM1-3.5	2%	3.5V	3 lead SOT-89
SPX2808AM1-3.5/TR	2%	3.5V	3 lead SOT-89
SPX2808M1-3.3	3%	3.3V	3 lead SOT-89
SPX2808M1-3.3/TR	3%	3.3V	3 lead SOT-89
SPX2808M1-3.5	3%	3.5V	3 lead SOT-89
SPX2808M1-3.5/TR	3%	3.5V	3 lead SOT-89
SPX2808AM3-3.3	2%	3.3V	3 lead SOT-223
SPX2808AM3-3.3/TR	2%	3.3V	3 lead SOT-223
SPX2808AM3-3.5	2%	3.5V	3 lead SOT-223
SPX2808AM3-3.5/TR	2%	3.5V	3 lead SOT-223
SPX2808M3-3.3	3%	3.3V	3 lead SOT-223
SPX2808M3-3.3/TR	3%	3.3V	3 lead SOT-223
SPX2808M3-3.5	3%	3.5V	3 lead SOT-223
SPX2808M3-3.5/TR	3%	3.5V	3 lead SOT-223

Available in lead free packaging. To order add “-L” suffix to part number.

Example: SPX2808M3-3.5/TR = standard; SPX2808M3-L-3.5/TR = lead free

/TR = Tape and Reel

Pack quantity is 2,500 for SOT-89 and SOT-223.



**ANALOG EXCELLENCE**

**Sipex Corporation**

**Headquarters and  
Sales Office**  
233 South Hillview Drive  
Milpitas, CA 95035  
TEL: (408) 934-7500  
FAX: (408) 935-7600

Sipex Corporation reserves the right to make changes to any products described herein. Sipex does not assume any liability arising out of the application or use of any product or circuit described herein; neither does it convey any license under its patent rights nor the rights of others.

**www.BDTIC.com/Exar/**