

Typical Applications

Transmit & Receive
Switch for 2.4 GHz Applications:

- Bluetooth
- HomeRF
- WLAN Radios

Features

Tx Gain: 15 dB, Rx Gain: 13 dB
Tx 1 dB Compression Point: 5 dBm
Rx Noise Figure: 3 dB @ 2.4 GHz
Single Positive Supply: +3V
No External Matching Required

Functional Diagram

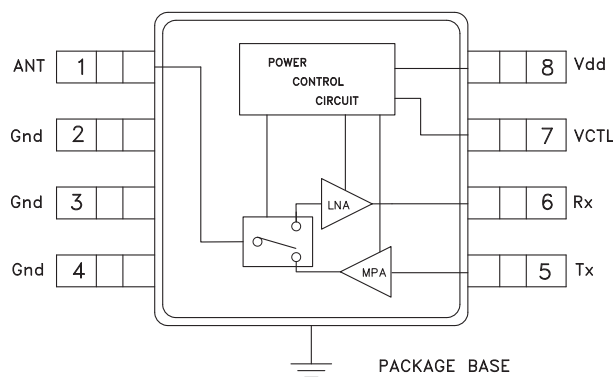

General Description

The HMC310MS8G & HMC310MS8GE are multi-function RFICs that incorporate a power amplifier (PA) and low noise amplifier (LNA) with a transmit/receive switch. These RFICs offer 15 dB gain and +5 dBm P1dB in the transmit mode and 13 dB of gain with an overall noise figure of 3 dB when in receive mode. Transmit and receive performance levels have been selected to meet the BLUETOOTH Class 2 & 3 requirements when used in conjunction with 2.4 GHz ASICs such as National Semiconductor's LMX3162. This low current and low cost transceiver requires no external circuitry to operate the amplifier power down features, and is available in the industry standard MSOP8G package, which is 0.118" x 0.190" (3.0mm x 4.9mm).

Electrical Specifications, $T_A = +25^\circ\text{C}$, $V_{dd} = +3\text{V}$

Parameter	Receive Mode			Transmit Mode			Units
	Min.	Rx Typ.	Max.	Min.	Tx Typ.	Max.	
Frequency Range	2.4 - 2.5			2.4 - 2.5			GHz
Gain	8	13	15	12	15	17	dB
Gain Variation over Temperature		0.03	0.04		0.03	0.04	dB/°C
Noise Figure		3.0	4.0				dB
Input Return Loss	4	6		4	7		dB
Output Return Loss	9	12		10	13		dB
Output Power for 1 dB Compression (P1dB)	-7	-4		1	5		dBm
Saturated Output Power (Psat)	-5	0		3	7		dBm
Output Third Order Intercept (IP3)	3	6		3	10		dBm
Supply Current (Idd)		12			24		mA

Rx Gain

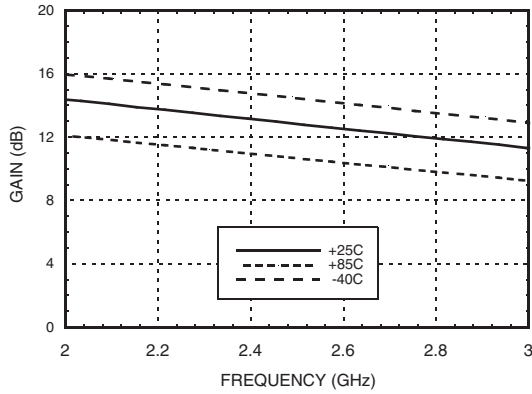

Rx Noise Figure

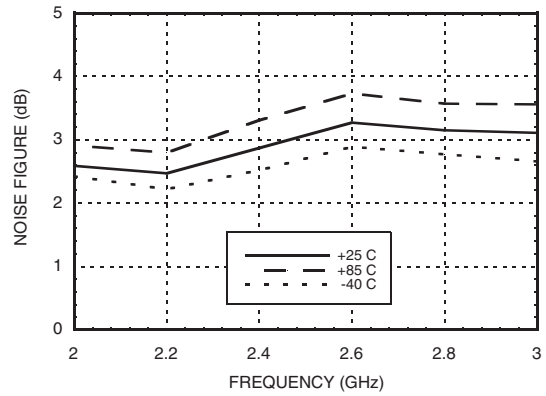

Rx Return Loss

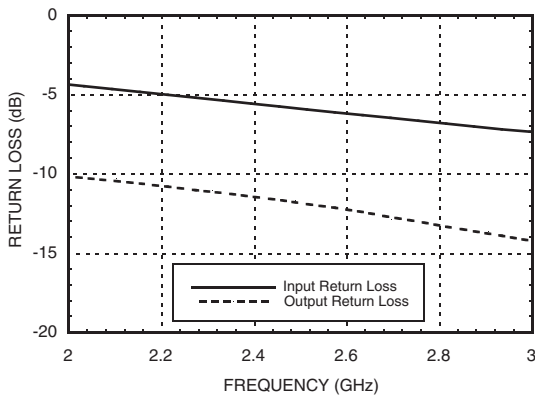

Rx 1dB Compression Point

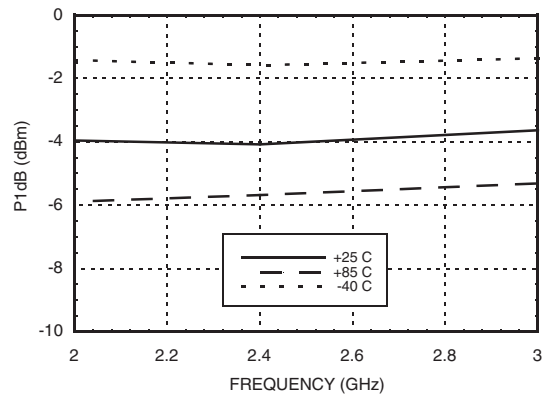

Rx Output Third Order Intercept Point

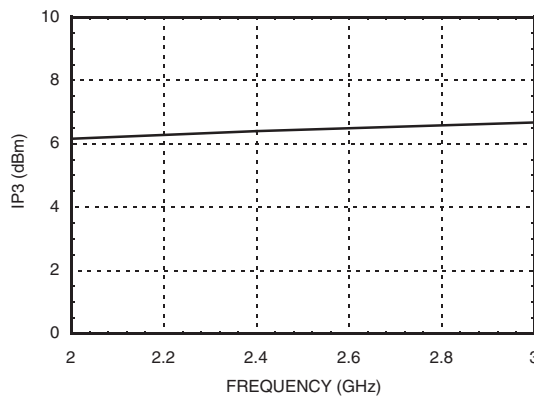

Tx Gain

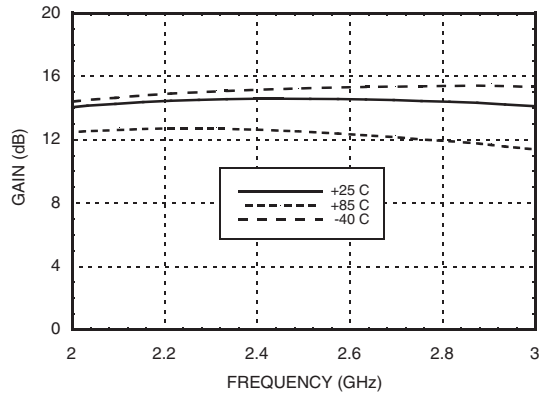

Tx Return Loss

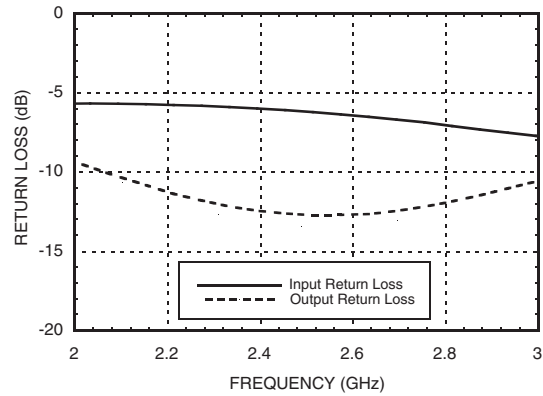

Tx 1dB Compression Point

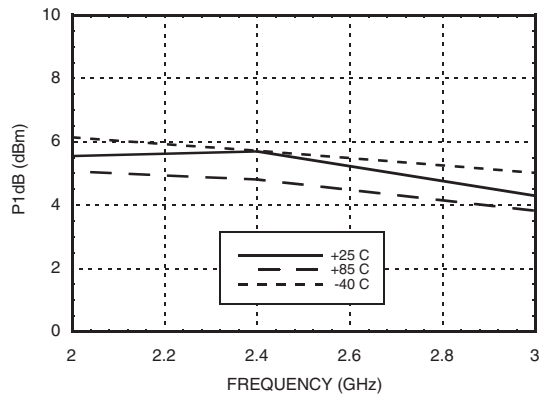

Tx Output Third Order Intercept Point

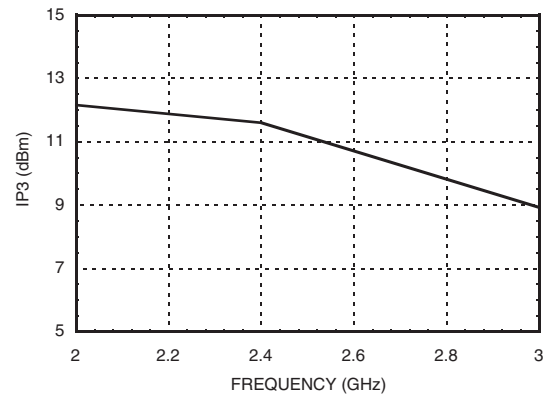

Absolute Maximum Ratings

Drain Bias Voltage (Vdd)	+7.0 Vdc
Control Voltage Range (Vctl)	-0.2 to Vdd
RF Input Power (Vdd = +3.0 Vdc)	0 dBm
Channel Temperature	150 °C
Continuous Pdiss (T = 85 °C) (derate 5 mW/°C above 85 °C)	0.325 W
Thermal Resistance (channel to ground paddle)	200 °C/W
Storage Temperature	-65 to +150 °C
Operating Temperature	-40 to +85 °C

Truth Table

Tx Section Active	VCTL = Vdd
Rx Section Active	VCTL = 0V



**ELECTROSTATIC SENSITIVE DEVICE
OBSERVE HANDLING PRECAUTIONS**

Outline Drawing

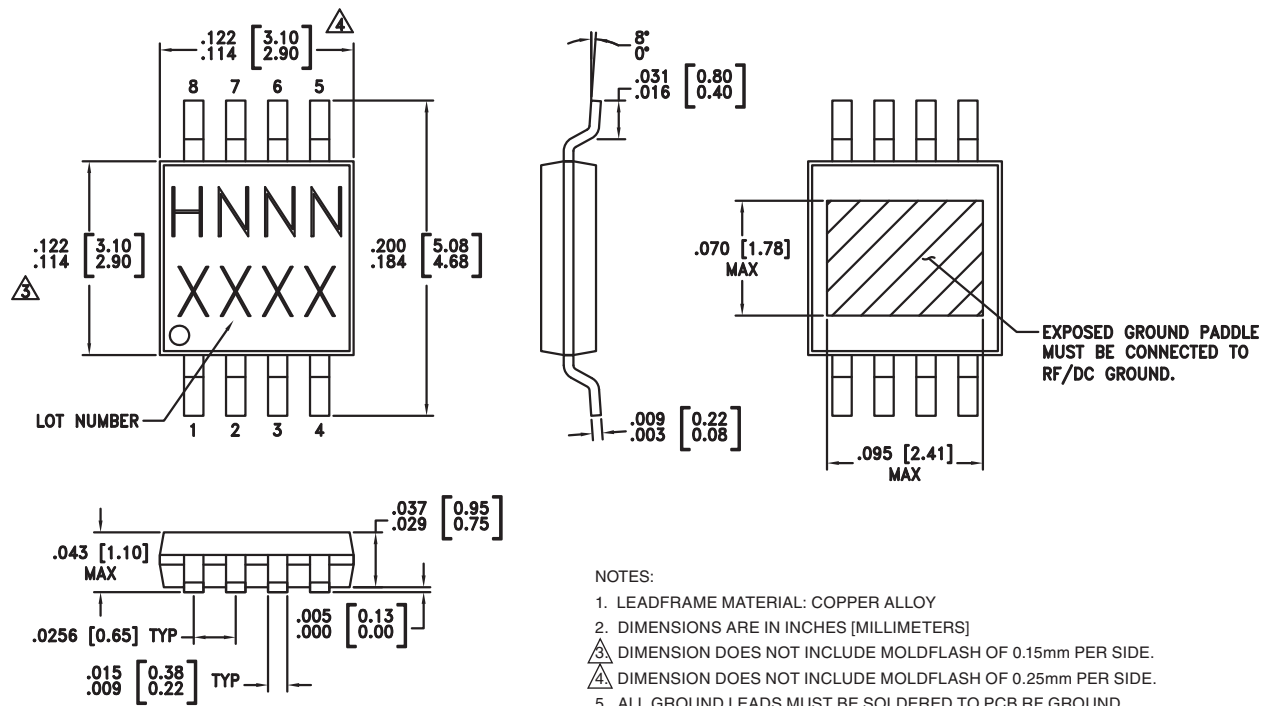

Package Information

Part Number	Package Body Material	Lead Finish	MSL Rating	Package Marking ^[3]
HMC310MS8G	Low Stress Injection Molded Plastic	Sn/Pb Solder	MSL1 ^[1]	H310 XXXX
HMC310MS8GE	RoHS-compliant Low Stress Injection Molded Plastic	100% matte Sn	MSL1 ^[2]	H310 XXXX

[1] Max peak reflow temperature of 235 °C

[2] Max peak reflow temperature of 260 °C

[3] 4-Digit lot number XXXX

Evaluation PCB

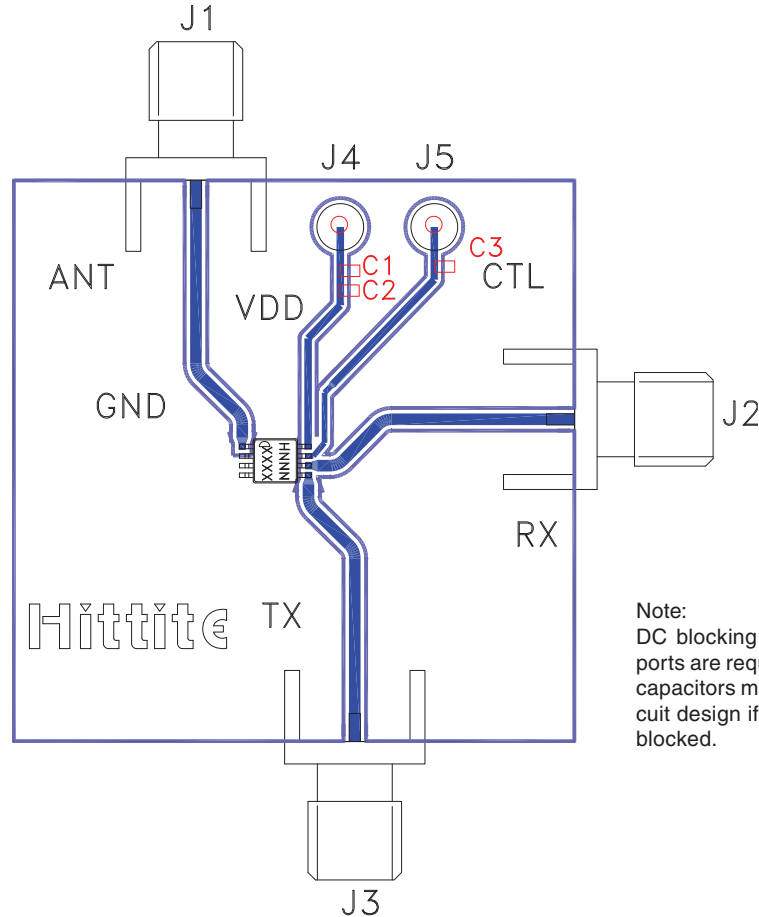

Note:
DC blocking capacitors on the Tx and ANT ports are required to evaluate this part. These capacitors may not be required in the final circuit design if interfacing components are DC blocked.

List of Materials for Evaluation PCB 103339 [1]

Item	Description
J1, J2, J3	PCB Mount SMA Connector
J4, J5	DC Pins
C1	.01 μ F Capacitor, 0603 Pkg.
C2, C3	100 pF Capacitor, 0603 Pkg.
U1	HMC310MS8G / HMC310MS8GE Transceiver
PCB [2]	Evaluation Board 1.5" x 1.55"

[1] Reference this number when ordering complete evaluation PCB

[2] Circuit Board Material: Rogers 4350

The circuit board used in the final application should use RF circuit design techniques. Signal lines should have 50 ohm impedance while the package ground leads and backside ground slug should be connected directly to the ground plane similar to that shown. A sufficient number of via holes should be used to connect the top and bottom ground planes. The evaluation circuit board shown is available from Hittite upon request.



Notes: