

Features

- LO 3.5 TO 18 GHz
- RF 6 TO 18 GHz
- IF DC TO 3000 MHz
- LO DRIVE +7 dBm (nominal)
- WIDE BANDWIDTH
- DC COUPLED I-PORT

Description

The M86 is a double balanced mixer, designed for use in military, commercial and test equipment applications. The design utilizes Schottky ring quad diodes and broadband soft dielectric and ferrite baluns to attain excellent performance. This mixer can also be used as a phase detector and/or bi-phase modulator since the IF port is DC coupled to the diodes. The use of high temperature solder and welded assembly processes used internally makes it ideal for use in manual, semi-automated assembly. Environmental screening available to MIL-STD-883, MIL-STD-202, or

Product Image

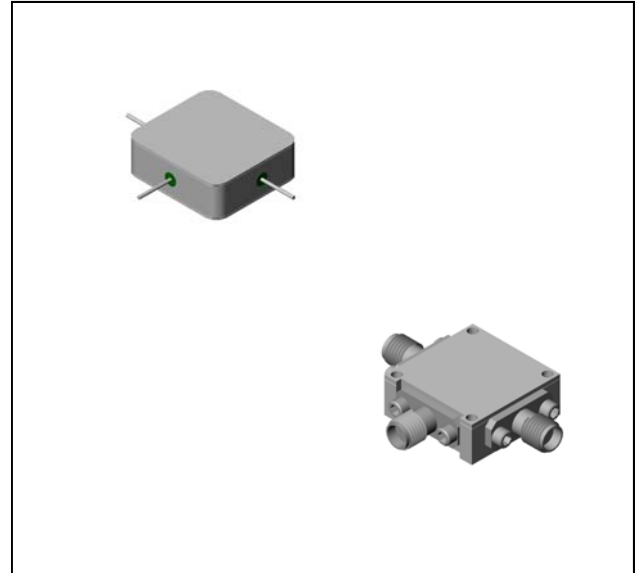

Ordering Information

Part Number	Package
M86	Minpac
M86C	SMA Connectorized

Electrical Specifications: $Z_0 = 50\Omega$ $Lo = +7$ dBm (Downconverter application only)

Parameter	Test Conditions	Units	Typical	Guaranteed	
				+25°C	-54° to +85°C
SSB Conversion Loss (max) & SSB Noise Figure (max)	fR = 6 to 16 GHz, fL = 5 to 17 GHz, fl = 30 to 1000 MHz	dB	6.0	8.0	8.5
	fR = 16 to 18 GHz, fL = 15 to 18 GHz, fl = 30 to 1000 MHz	dB	7.0	9.0	9.5
	fR = 6 to 18 GHz, fL = 3.5 to 18 GHz, fl = 30 to 3000 MHz	dB	7.0	9.0	9.5
Isolation, L to R (min)	fL = 3.5 to 14 GHz	dB	36	23	21
	fL = 14 to 18 GHz	dB	32	18	16
Isolation, L to I (min)	fL = 3.5 to 9 GHz	dB	28	16	14
	fL = 9 to 18 GHz	dB	38	23	21
1 dB Conversion Comp.	fL = +7 dBm	dBm	+3		
Input IP3	fR1=13 GHz at -10 dBm, fR2=13.01GHz at -10 dBm, fL = 14 GHz at = +7 dBm	dBm	+10		

Typical Performance Curves

Conversion Loss vs. LO Power

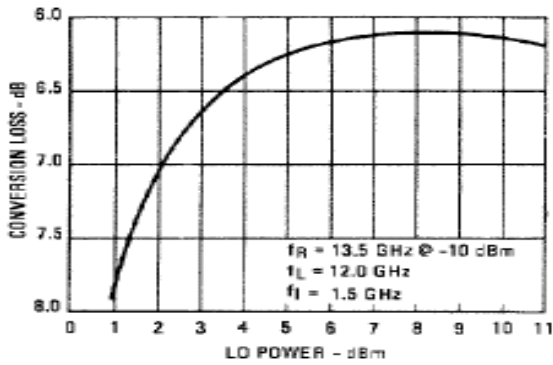

Conversion Loss

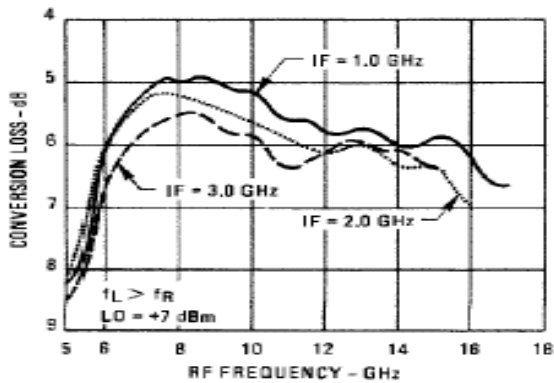
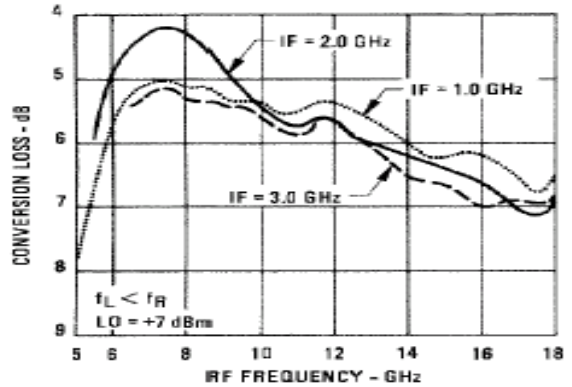

Isolation

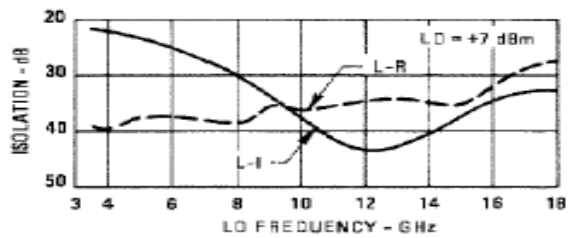

Conversion Loss

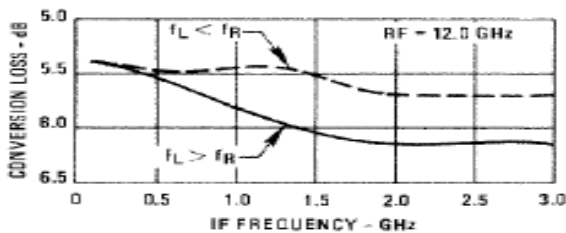

VSWR

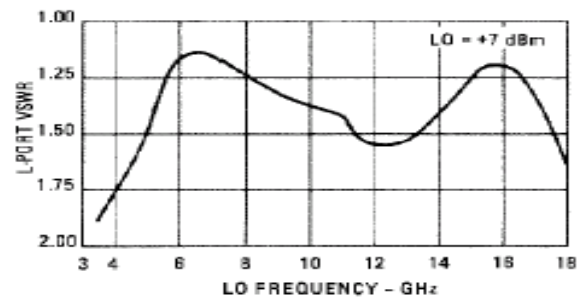

M86 / M86C



Double-Balanced Mixer

Rev. V2

Absolute Maximum Ratings

Parameter	Absolute Maximum
Operating Temperature	-54°C to +100°C
Storage Temperature	-65°C to +100°C
Peak Input Power	+23 dBm max @ +25°C +20 dBm max @ +100°C
Peak Input Current	100 mA DC

Outline Drawing: Minpac *

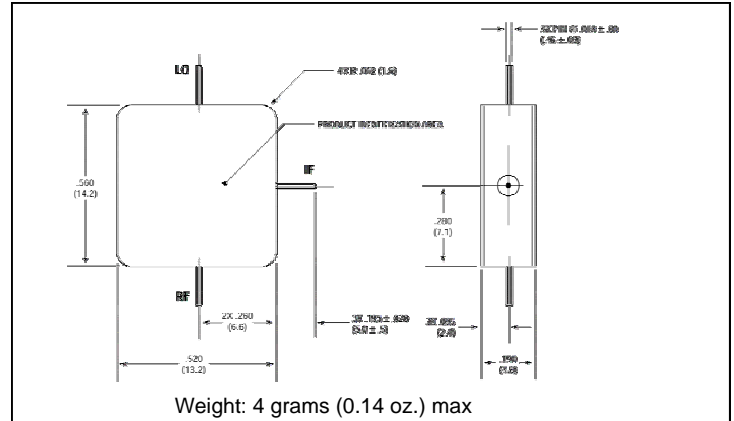

Outline Drawing: SMA Connectorized *

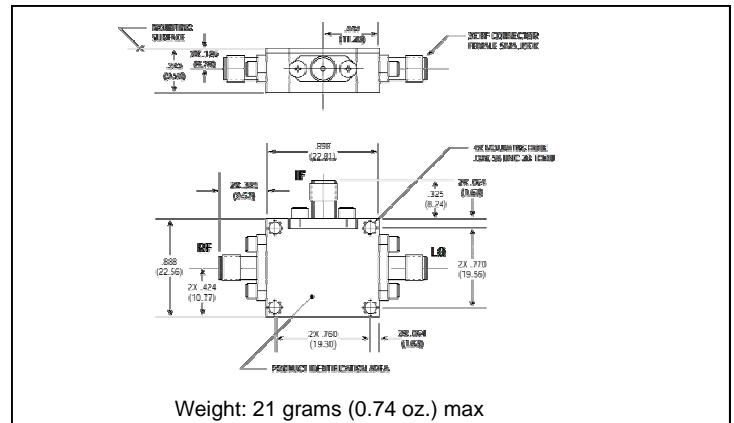

VSWR

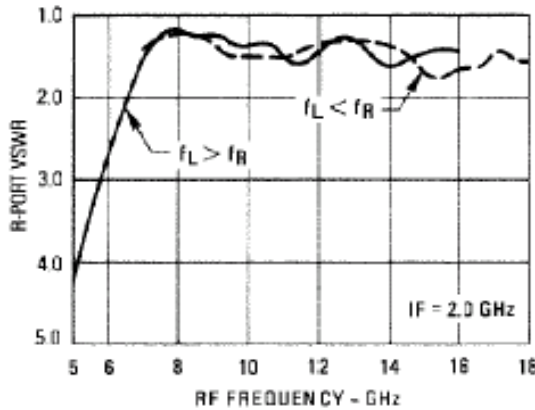

* Dimensions are inches (millimeters) ±0.015 (0.38) unless otherwise specified.

VSWR

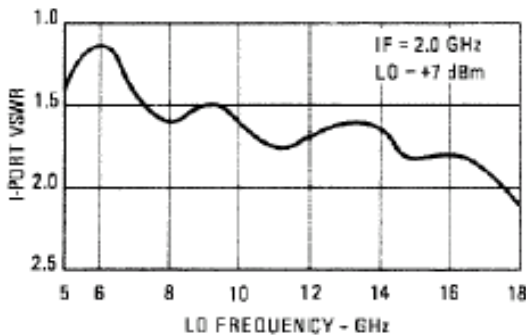

VSWR

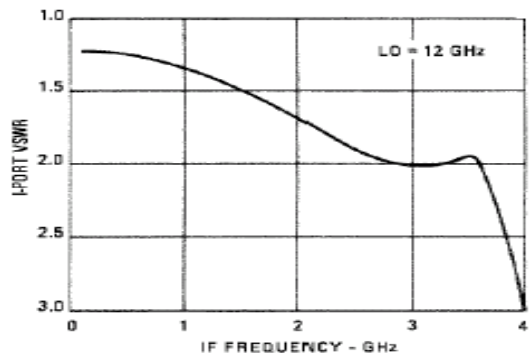

ADVANCED: Data Sheets contain information regarding a product M/A-COM Technology Solutions is considering for development. Performance is based on target specifications, simulated results, and/or prototype measurements. Commitment to develop is not guaranteed.
PRELIMINARY: Data Sheets contain information regarding a product M/A-COM Technology Solutions has under development. Performance is based on engineering tests. Specifications are typical. Mechanical outline has been fixed. Engineering samples and/or test data may be available. Commitment to produce in volume is not guaranteed.

• **North America** Tel: 800.366.2266 • **Europe** Tel: +353.21.244.6400
 • **India** Tel: +91.80.4155721 • **China** Tel: +86.21.2407.1588
 Visit www.macomtech.com for additional data sheets and product information.

M/A-COM Technology Solutions and its affiliates reserve the right to make changes to the products and information contained herein without notice.