

UF28150J



RF Power MOSFET Transistor
150W, 100MHz-500MHz, 28V

M/A-COM Products
Released; RoHS Compliant

Features

- DMOS structure
- Lower capacitance for broadband operation
- Common source configuration

ABSOLUTE MAXIMUM RATINGS^{1, 2, 3}

Parameter	Symbol	Rating	Units
Drain-Source Voltage	V_{DS}	65	V
Gate-Source Voltage	V_{GS}	20	V
Drain-Source Current	I_{DS}	16*	A
Power Dissipation	P_D	389	W
Junction Temperature	T_J	200	°C
Storage Temperature	T_{STG}	-65 to +150	°C
Thermal Resistance	Θ_{JC}	0.45	°C/W

1. Exceeding any one or combination of these limits may cause permanent damage to this device.
2. M/A-COM does not recommend sustained operation near these maximum limits.
3. At 25°C Tcase, unless noted.

Package Outline

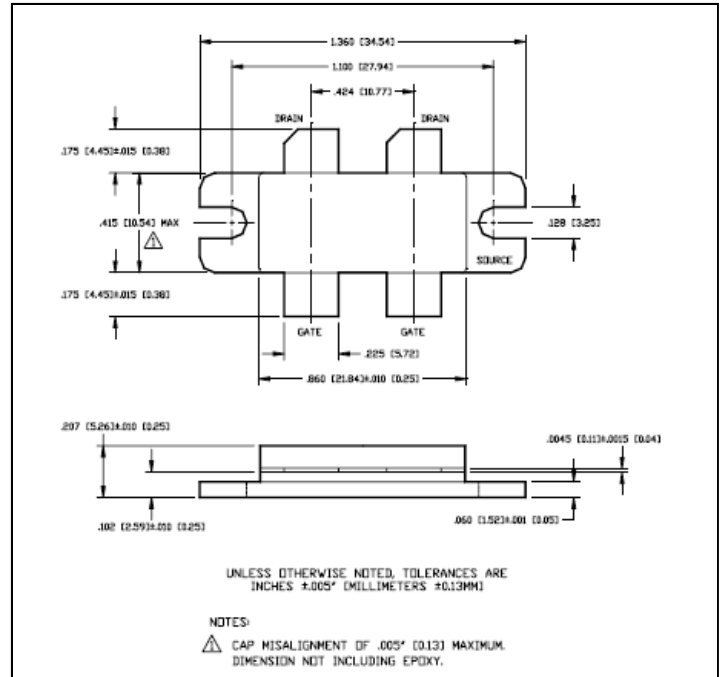

ELECTRICAL SPECIFICATIONS: 25°C

Parameter	Test Conditions	Units	Min.	Max.
Drain-Source Breakdown Voltage	$V_{GS} = 0.0\text{ V}$, $I_{DS} = 20.0\text{ mA}^*$	BV_{DSS}	65	—
Drain-Source Leakage Current	$V_{DS} = 28.0\text{ V}$, $V_{GS} = 0.0\text{ V}^*$	I_{DSS}	—	4.0
Gate-Source Leakage Current	$V_{GS} = 20\text{ V}$, $V_{DS} = 0.0\text{ V}^*$	I_{GSS}	—	4.0
Gate Threshold Voltage	$V_{DS} = 10.0\text{ V}$, $I_{DS} = 400.0\text{ mA}^*$	$V_{GS(TH)}$	2.0	6.0
Forward Transconductance	$V_{DS} = 10.0\text{ V}$, $I_{DS} = 4000.0\text{ mA}$, $\Delta V_{GS} = 1.0\text{ V}$, 80 μs pulse*	G_M	2.0	—
Input Capacitance	$V_{DS} = 28.0\text{ V}$, $F = 1.0\text{ MHz}^*$	C_{ISS}	—	180
Output Capacitance	$V_{DS} = 28.0\text{ V}$, $F = 1.0\text{ MHz}^*$	C_{OSS}	—	120
Reverse Capacitance	$V_{DS} = 28.0\text{ V}$, $F = 1.0\text{ MHz}^*$	C_{RSS}	—	32
Power Gain	$V_{DD} = 28.0\text{ V}$, $I_{DQ} = 400.0\text{ mA}$, $P_{OUT} = 150.0\text{ W}$, $F = 500\text{ MHz}$	G_P	8	—
Drain Efficiency	$V_{DD} = 28.0\text{ V}$, $I_{DQ} = 400.0\text{ mA}$, $P_{OUT} = 150.0\text{ W}$, $F = 500\text{ MHz}$	η_D	55	—
Load Mismatch Tolerance	$V_{DD} = 28.0\text{ V}$, $I_{DQ} = 400.0\text{ mA}$, $P_{OUT} = 150.0\text{ W}$, $F = 500\text{ MHz}$	VSWR-T	—	10:1**

Notes:

* Per side

** At all phase angles

ADVANCED: Data Sheets contain information regarding a product M/A-COM Technology Solutions is considering for development. Performance is based on target specifications, simulated results, and/or prototype measurements. Commitment to develop is not guaranteed.

PRELIMINARY: Data Sheets contain information regarding a product M/A-COM Technology Solutions has under development. Performance is based on engineering tests. Specifications are typical. Mechanical outline has been fixed. Engineering samples and/or test data may be available. Commitment to produce in volume is not guaranteed.

• **North America** Tel: 800.366.2266 / Fax: 978.366.2266
 • **Europe** Tel: 44.1908.574.200 / Fax: 44.1908.574.300
 • **Asia/Pacific** Tel: 81.44.844.8296 / Fax: 81.44.844.8298
 Visit www.macomtech.com for additional data sheets and product information.

M/A-COM Technology Solutions Inc. and its affiliates reserve the right to make changes to the product(s) or information contained herein without notice.

Typical Broadband Performance Curves

Capacitance vs Voltage
 $F=1.0$ MHz

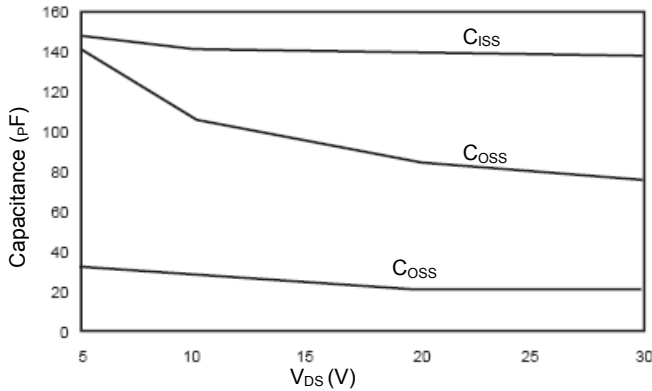

Power Output vs Voltage
 $P_{IN}=24$ W $I_{DQ}=400$ mA $F=500$ MHz

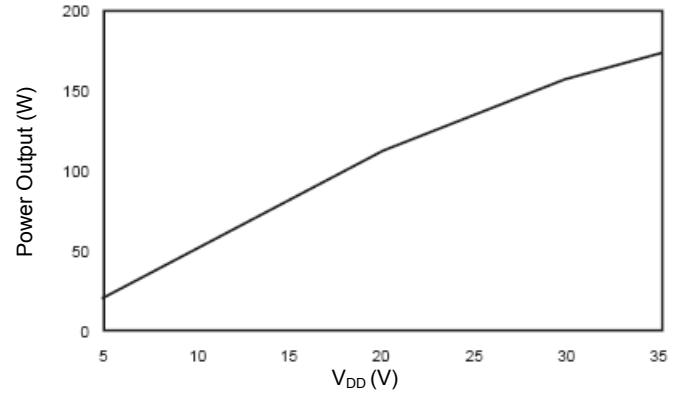

Gain vs Frequency
 $V_{DD}=28$ V $P_{OUT}=100$ W $I_{DQ}=400$ mA

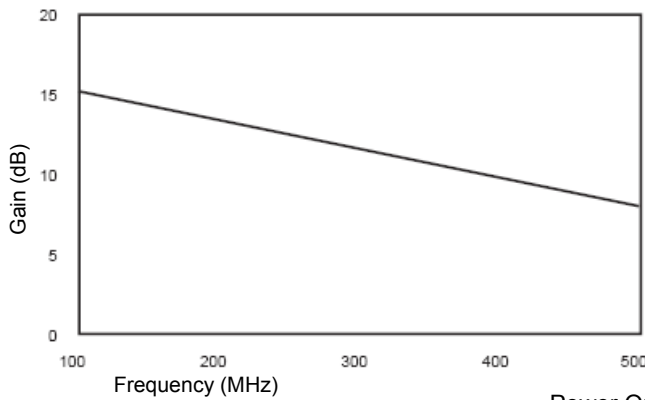

Efficiency vs Frequency
 $V_{DD}=28$ V $I_{DQ}=400$ mA $P_{OUT}=150$ W

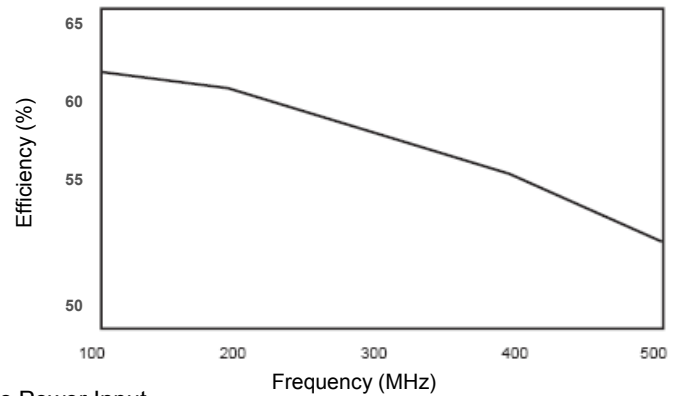

Power Output vs Power Input
 $V_{DD}=28$ V $I_{DQ}=400$ mA

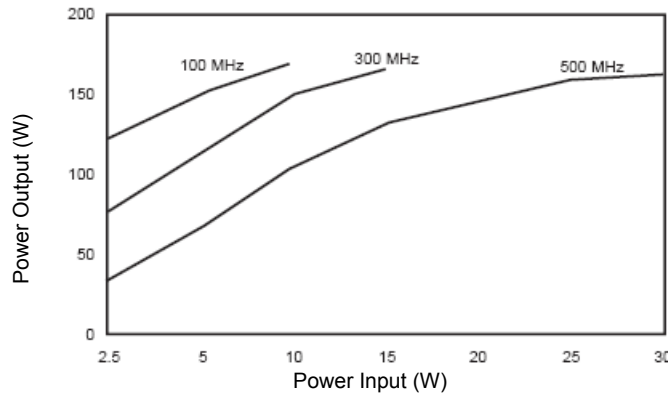

UF28150J



RF Power MOSFET Transistor
150W, 100MHz-500MHz, 28V

M/A-COM Products
Released; RoHS Compliant

TYPICAL OPTIMUM DEVICE IMPEDANCES

F (MHz)	Z _{IN} (Ω)	Z _{LOAD} (Ω)
100	3.7 - j5.9	3.0 - j0.7
300	2.7 - j5.9	2.6 - j0.55
500	2.5 - j2.9	2.5 - j0.5

V_{DD} = 28V, I_{DQ} = 400mA, P_{OUT} = 150W

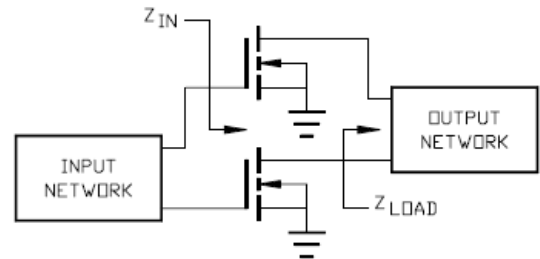

PARTS LIST

C23	1.0pF
C1	9.1pF
C12	11pF
C2, 3, 13, 22	270pF
C7, 16	680pF
C4, 6, 15, 17	.015uF
C18	50uF 50V
R1	11K OHM .25 W. 10%
R2	47 OHM .05 W. 10%
R3	12 OHM .25 W. 10%
T1	2.50' OF 50 OHM (.85' OD) SEMI-RIGID CABLE
T2,3,4,5	2.50' OF 10 OHM (.70' OD) SEMI-RIGID CABLE
T6	2.50' OF 50 OHM (.141' OD) SEMI-RIGID CABLE
L1	5uH
L2	16 TURNS OF NO. 18 AWG ON TORID CORE (INDIANA GENERAL F6278-Q1)
L3,4	4 TURNS OF NO. 18 AWG ON .125 DIAMETER
RL1	9 TURNS OF NO. 18 AWG ON 15 OHM 2 W. 10% RESISTOR
Q1A, 1B	UF28150J

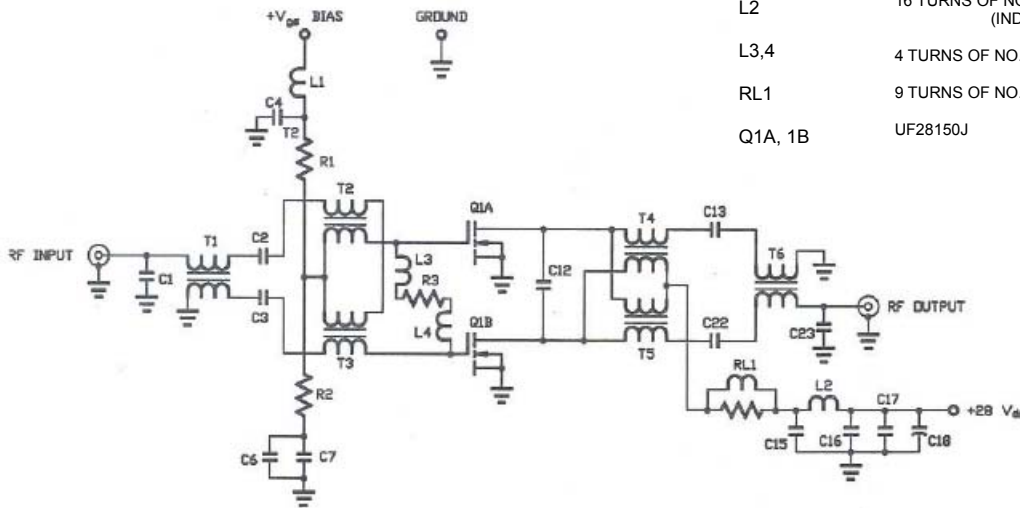
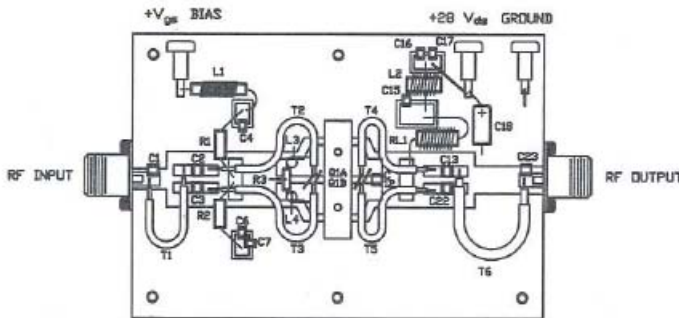

HANDLING PROCEDURES: STATIC SENSITIVITY

Please observe the following precautions to avoid damage:

DMOS devices are sensitive to electrostatic discharge (ESD) and can be damaged by static electricity. Proper ESD control techniques should be used when handling these devices.