

# XB1004-BD



**Buffer Amplifier**  
**16.0-30.0 GHz**

Rev. V1  
MimiX Broadband

## Features

- High Dynamic Range
- Excellent LO Driver/Buffer Amplifier
- Low Noise or Power Bias Configurations
- 21.0 dB Small Signal Gain
- 2.2 dB Noise Figure at Low Noise Bias
- +19.0 dBm P1dB Compression Point at Power Bias
- 100% On-Wafer RF, DC and Noise Figure Testing
- 100% Visual Inspection to MIL-STD-883 Method 2010
- RoHS\* Compliant and 260°C Reflow Compatible

## Description

M/A-COM Tech's three stage 16.0-30.0 GHz GaAs MMIC buffer amplifier has a small signal gain of 21.0 dB with a noise figure of 2.2 dB across the band. This MMIC uses M/A-COM Tech's GaAs PHEMT device model technology, and is based upon electron beam lithography to ensure high repeatability and uniformity. The chip has surface passivation to protect and provide a rugged part with backside via holes and gold metallization to allow either a conductive epoxy or eutectic solder die attach process. This device is well suited for Millimeter-wave Point-to-Point Radio, LMDS, SATCOM and VSAT applications.

## Chip Device Layout

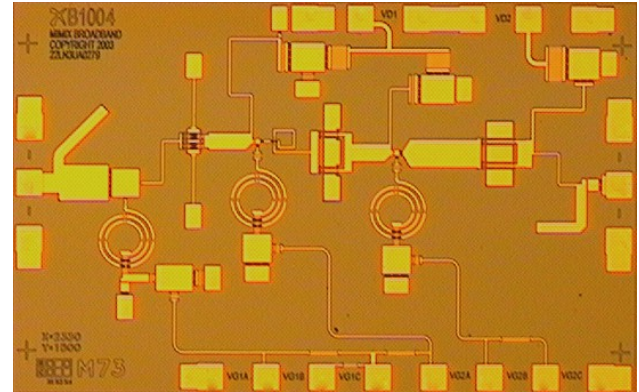

## Absolute Maximum Ratings

| Parameter                  | Absolute Max.                     |
|----------------------------|-----------------------------------|
| Supply Voltage (Vd)        | +6.5 VDC                          |
| Supply Current (Id)        | 200 mA                            |
| Gate Bias Voltage (Vg)     | +0.3 V                            |
| Input Power (Pin)          | +5 dBm                            |
| Storage Temperature (Tstg) | -65 °C to +165 °C                 |
| Operating Temperature (Ta) | -55 °C to MTTF Table <sup>1</sup> |
| Channel Temperature (Tch)  | MTTF Table <sup>1</sup>           |

1. Channel temperature directly affects a device's MTTF. Channel temperature should be kept as low as possible to maximize lifetime.

## Ordering Information

| Part Number    | Package                       |
|----------------|-------------------------------|
| XB1004-BD-000V | "V" - vacuum release gel paks |
| XB1004-BD-000W | "W" - waffle trays            |
| XB1004-BD-EV1  | evaluation module             |

## Electrical Specifications: 16-30 GHz (Ambient Temperature T = 25°C)

| Parameter  | Units | Min. | Typ.   | Max. |
|--|-------|------|--------|------|
| Input Return Loss (S11) <sup>3</sup>                           | dB    | -    | 15.0   | -    |
| Output Return Loss (S22) <sup>3</sup>                          | dB    | -    | 17.0   | -    |
| Small Signal Gain (S21) <sup>3</sup>                           | dB    | -    | 18.0   | -    |
| Gain Flatness ( $\Delta S21$ )                                 | dB    | -    | +/-2.0 | -    |
| Reverse Isolation (S12) <sup>3</sup>                           | dB    | -    | 35.0   | -    |
| Noise Figure (NF) <sup>4</sup>                                 | dB    | -    | 5.5    | -    |
| Output Power for 1dB Compression Point (P1dB) <sup>1,2,3</sup> | dBm   | -    | +20.0  | -    |
| Saturated Output Power (Psat) <sup>1,2,3</sup>                 | dBm   | -    | +22.0  | -    |
| Drain Bias Voltage (Vd1,2)                                     | VDC   | -    | +4.0   | +4.0 |
| Gate Bias Voltage (Vg1c,2c)                                    | VDC   | -1.0 | -0.23  | -0.1 |
| Supply Current (Id) (Vd=4.0 V, Vg=-0.3 V Typical)              | mA    | -    | 100    | 130  |

1. Optional low noise bias Vd1,2=4.0 V, Id=90 mA will typically yield 3-4 dB decreased P1dB and OIP3.
2. Measured using constant current.
3. Unless otherwise indicated Min/Max over 17.0-28.0 GHz and biased at Vd=6.0 V, Id1=90 mA, Id2=90 mA.
4. Unless otherwise indicated Min/Max over 17.0-28.0 GHz and biased at Vd=4.0 V, Id1=45 mA, Id2=45 mA.

## Typical Performance Curves

XB1004-BD Vd1,2=4.0 V Id1=22.5 mA, Id2=45 mA  
~7000 Devices

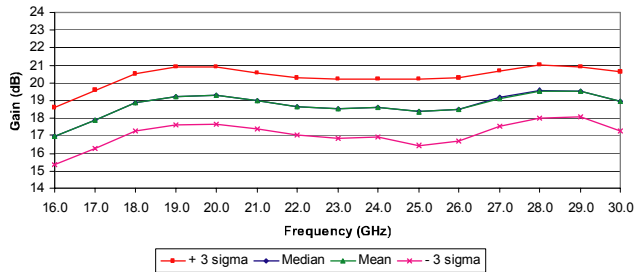

XB1004-BD Vd1,2=4.0 V Id1=22.5 mA, Id2=45 mA  
~7000 Devices

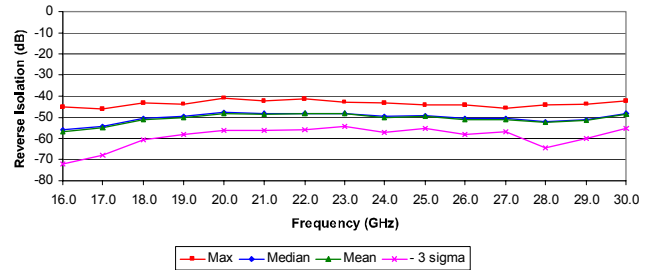

XB1004-BD Vd1,2=4.0 V Id1=22.5 mA, Id2=45 mA  
~7000 Devices

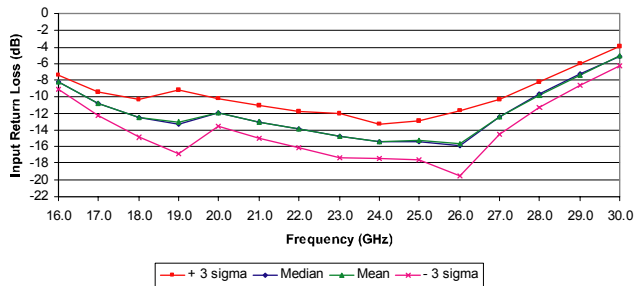

XB1004-BD Vd1,2=4.0 V Id1=22.5 mA, Id2=45 mA  
~7000 Devices

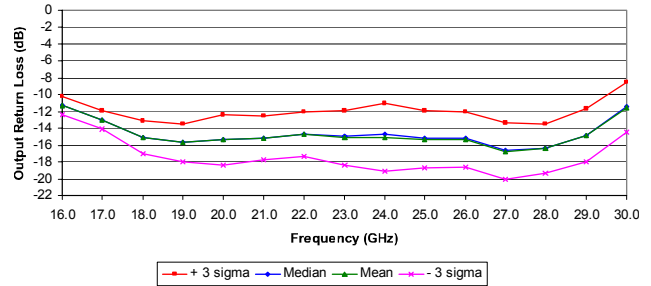

# XB1004-BD



Buffer Amplifier  
16.0-30.0 GHz

Rev. V1  
MimiX Broadband

## Typical Performance Curves (cont.)

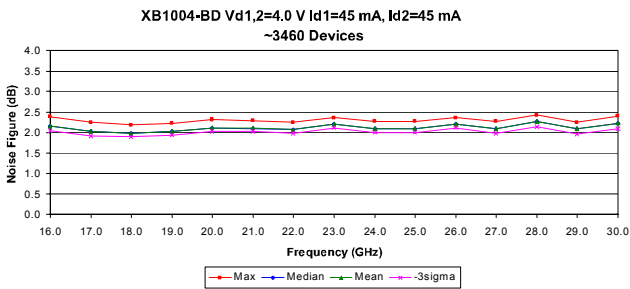
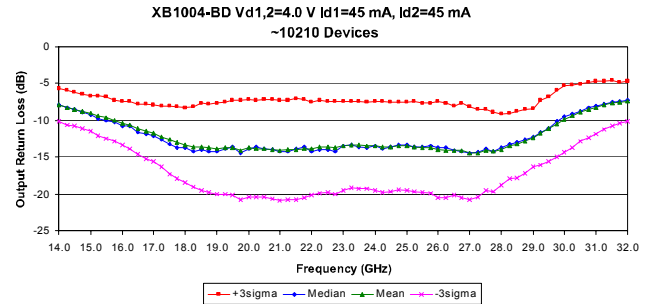
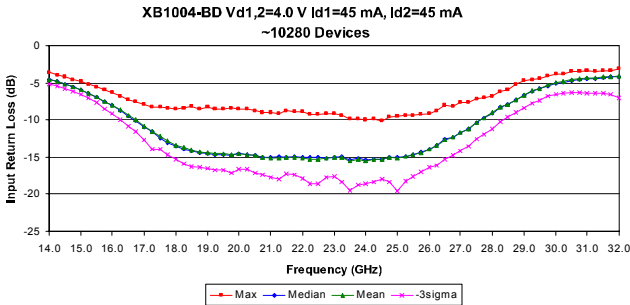
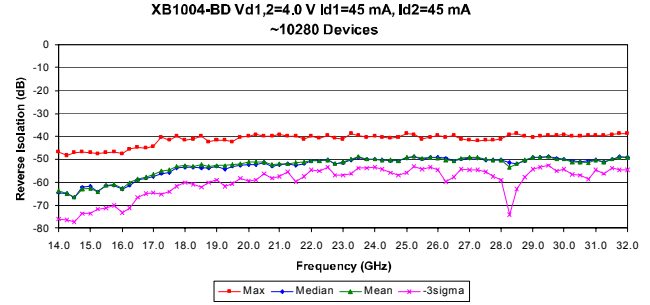
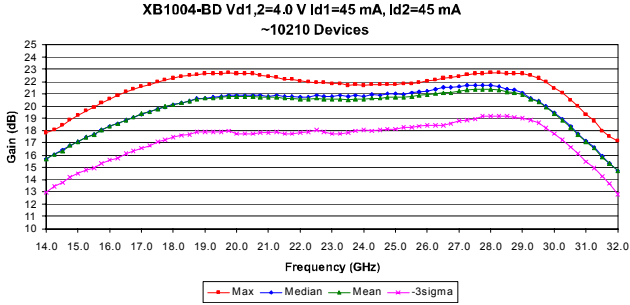

**ADVANCED:** Data Sheets contain information regarding a product M/A-COM Technology Solutions is considering for development. Performance is based on target specifications, simulated results, and/or prototype measurements. Commitment to develop is not guaranteed.  
**PRELIMINARY:** Data Sheets contain information regarding a product M/A-COM Technology Solutions has under development. Performance is based on engineering tests. Specifications are typical. Mechanical outline has been fixed. Engineering samples and/or test data may be available. Commitment to produce in volume is not guaranteed.

• **North America** Tel: 800.366.2266 • **Europe** Tel: +353.21.244.6400  
• **India** Tel: +91.80.43537383 • **China** Tel: +86.21.2407.1588  
Visit [www.macomtech.com](http://www.macomtech.com) for additional data sheets and product information.

M/A-COM Technology Solutions Inc and its affiliates reserve the right to make changes to the product(s) or information contained herein without notice.

# XB1004-BD



Buffer Amplifier  
16.0-30.0 GHz

Rev. V1  
MimiX Broadband

## Typical Performance Curves (cont.)

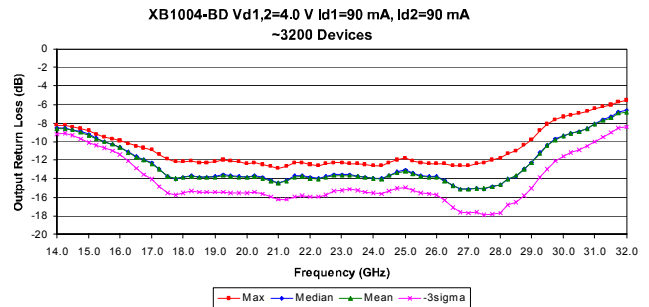
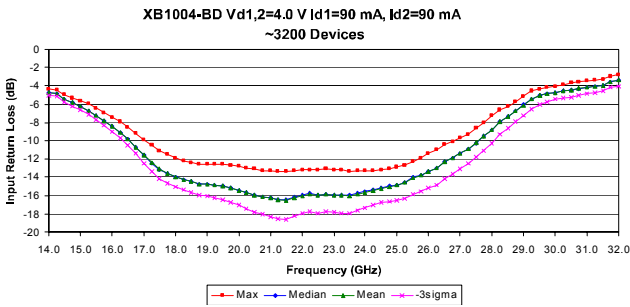
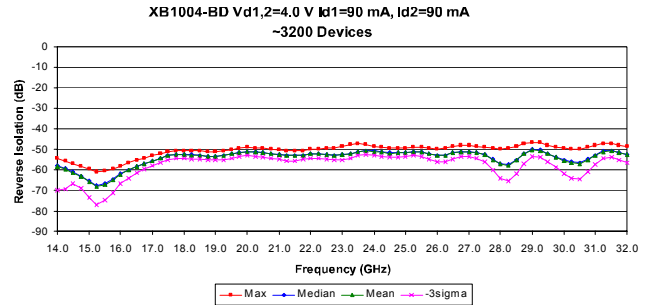
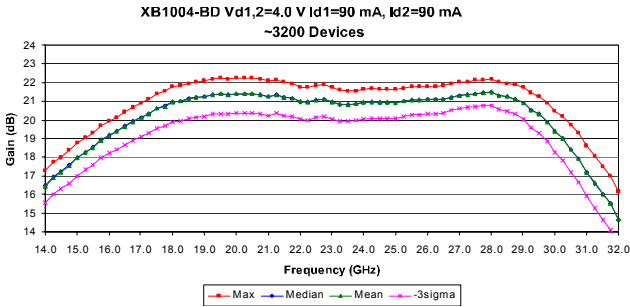

**ADVANCED:** Data Sheets contain information regarding a product M/A-COM Technology Solutions is considering for development. Performance is based on target specifications, simulated results, and/or prototype measurements. Commitment to develop is not guaranteed.  
**PRELIMINARY:** Data Sheets contain information regarding a product M/A-COM Technology Solutions has under development. Performance is based on engineering tests. Specifications are typical. Mechanical outline has been fixed. Engineering samples and/or test data may be available. Commitment to produce in volume is not guaranteed.

• **North America** Tel: 800.366.2266 • **Europe** Tel: +353.21.244.6400  
 • **India** Tel: +91.80.43537383 • **China** Tel: +86.21.2407.1588  
 Visit [www.macomtech.com](http://www.macomtech.com) for additional data sheets and product information.

M/A-COM Technology Solutions Inc and its affiliates reserve the right to make changes to the product(s) or information contained herein without notice.

## Typical Performance Curves (cont.)

XB1004-BD\_R2C2: Pout vs. freq\_R2C2

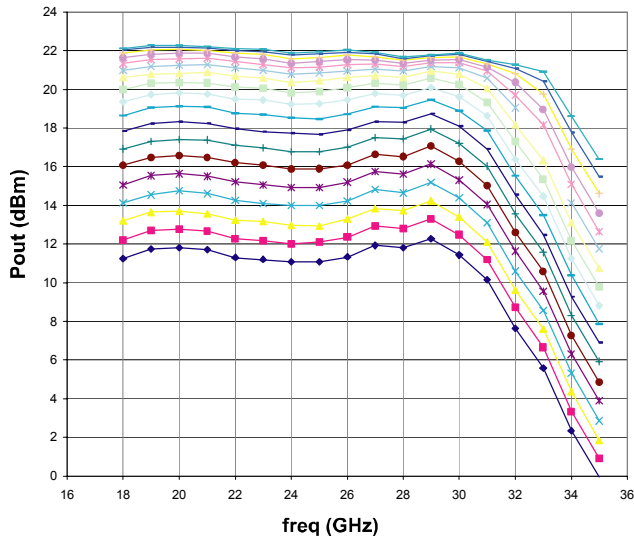

XB1004-BD: Pout vs. freq at -10, -3 and 7dBm

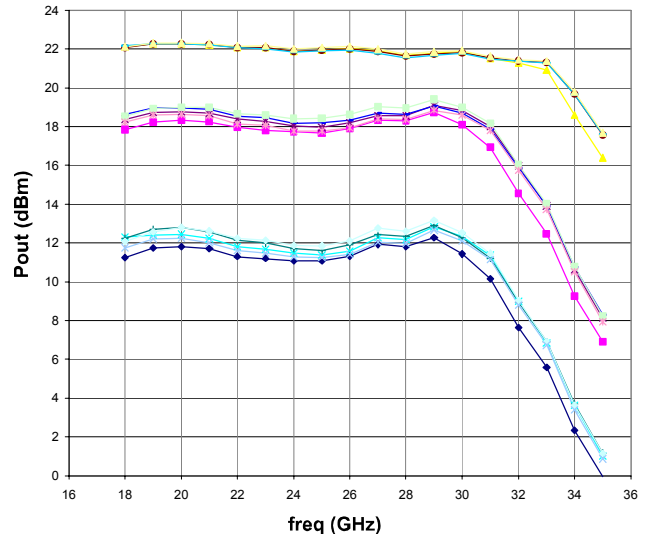

XB1004-BD\_R3C3: OP1dB

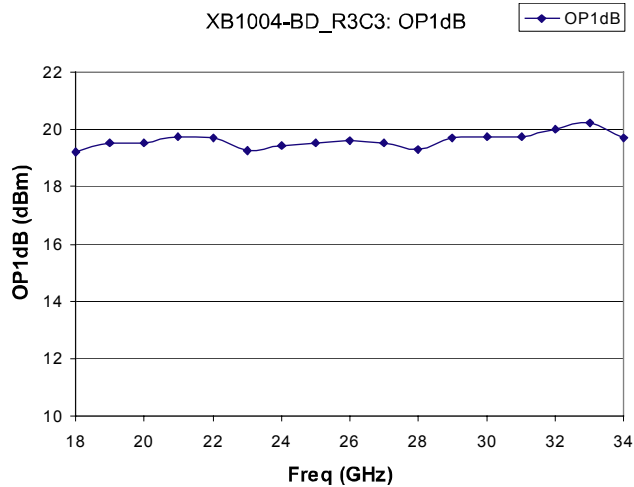

## Buffer Amplifier 16.0-30.0 GHz

Rev. V1  
MimiX Broadband

### S-Parameters

Typical S-Parameter Data for XB1004-BD  
Vd=4 V Id1=45 mA Id2=45 mA

| Frequency (GHz) | S11 Mag dB   | S11 Phase Ang° | S12 Mag dB   | S12 Phase Ang° | S21 Mag dB  | S21 Phase Ang° | S22 Mag dB   | S22 Phase Ang° |
|-----------------|--------------|----------------|--------------|----------------|-------------|----------------|--------------|----------------|
| 14.00           | -4.488006386 | 160.3477       | -65.20547853 | 97.9597        | 15.91141774 | 80.4131        | -7.961292105 | 156.364        |
| 14.25           | -4.780466353 | 156.7746       | -65.04914525 | 130.745        | 16.26308988 | 72.75384       | -8.307793633 | 81.76258       |
| 14.50           | -5.090069626 | 153.2923       | -66.83487195 | 144.4173       | 16.58581284 | 66.05664       | -8.516462366 | 17.58182       |
| 14.75           | -5.515642302 | 149.3398       | -62.82813364 | 145.9903       | 16.96448878 | 58.3271        | -8.817693057 | -60.40213      |
| 15.00           | -5.908319039 | 146.0351       | -62.15152842 | 140.1351       | 17.27640243 | 51.4296        | -9.116250938 | -125.5226      |
| 15.25           | -6.36492729  | 142.3947       | -63.79403343 | 139.2024       | 17.6306096  | 43.16068       | -9.490746359 | 152.1885       |
| 15.50           | -6.835321917 | 139.2067       | -61.55571655 | 135.3048       | 17.89655959 | 36.43289       | -9.758978333 | 91.87538       |
| 15.75           | -7.443645645 | 135.8314       | -61.61834811 | 136.4185       | 18.23731044 | 27.96522       | -10.0850734  | 15.17566       |
| 16.00           | -7.954014568 | 133.451        | -62.87801498 | 130.6166       | 18.53392439 | 21.13839       | -10.44926621 | -49.12296      |
| 16.25           | -8.613494027 | 130.5553       | -60.97586254 | 155.2967       | 18.79434566 | 12.62619       | -10.70325156 | -126.3388      |
| 16.50           | -9.351339718 | 128.5114       | -59.08234194 | 149.3536       | 19.06419509 | 4.264312       | -11.23343585 | 150.939        |
| 16.75           | -9.938284456 | 126.7418       | -58.07570032 | 153.9659       | 19.2955573  | -2.923985      | -11.49338288 | 89.83047       |
| 17.00           | -10.72781907 | 125.6761       | -57.10236855 | 145.1132       | 19.55954352 | -11.07268      | -11.84807057 | 15.57915       |
| 17.25           | -11.45757287 | 125.1995       | -55.63348472 | 146.4742       | 19.73877049 | -18.24617      | -12.26263506 | -47.66284      |
| 17.50           | -12.10581429 | 125.4995       | -55.25927565 | 142.45         | 19.96235376 | -27.11272      | -12.70872047 | -123.7843      |
| 17.75           | -12.78314466 | 126.4037       | -53.62911008 | 137.6782       | 20.12122686 | -33.96728      | -13.08797618 | 167.1598       |
| 18.00           | -13.40563631 | 128.1031       | -53.49785092 | 126.705        | 20.31749415 | -42.63926      | -13.38602103 | 94.69427       |
| 18.25           | -13.76917019 | 130.3096       | -53.59193789 | 118.0486       | 20.45549686 | -50.03904      | -13.55092416 | 35.52287       |
| 18.50           | -14.12698    | 132.3081       | -53.18089883 | 118.702        | 20.58039147 | -58.52836      | -13.66587745 | -40.1016       |
| 18.75           | -14.48203359 | 134.6221       | -53.36091684 | 115.3193       | 20.75502996 | -67.11792      | -13.7915767  | -115.0743      |
| 19.00           | -14.55165735 | 136.2222       | -52.97969443 | 109.4043       | 20.80511699 | -74.15998      | -13.84992904 | 44.88443       |
| 19.25           | -14.63942028 | 136.5078       | -53.42822181 | 101.9631       | 20.86890808 | -82.84879      | -13.7461338  | 102.1477       |
| 19.50           | -14.68157629 | 137.3111       | -53.1769237  | 103.6469       | 20.93192687 | -89.86997      | -13.75692934 | 41.94405       |
| 19.75           | -14.74099805 | 139.6776       | -52.39693469 | 104.5834       | 20.97333211 | -97.89622      | -14.05814122 | -33.67156      |
| 20.00           | -14.51000349 | 138.8338       | -51.49852234 | 95.15817       | 20.98201169 | -105.3744      | -13.81447312 | -96.83292      |
| 20.25           | -14.62534716 | 138.1341       | -51.66603657 | 96.65334       | 20.98524967 | -113.0653      | -13.90279702 | -168.5283      |
| 20.50           | -14.70616526 | 136.6651       | -51.38333793 | 82.06539       | 20.99616315 | -120.2752      | -13.77821296 | 120.4647       |
| 20.75           | -14.90553527 | 136.5904       | -52.71399942 | 82.86057       | 20.96910204 | -128.1374      | -13.92470348 | 44.1559        |
| 21.00           | -15.02357419 | 135.813        | -52.10524654 | 79.37607       | 20.89622002 | -135.913       | -14.0619026  | -31.24287      |
| 21.25           | -15.05015808 | 135.6739       | -52.02010887 | 76.92526       | 20.91884446 | -142.6171      | -14.0289345  | -93.15093      |
| 21.50           | -15.10655145 | 134.7054       | -52.22623499 | 71.78536       | 20.84428402 | -150.0642      | -13.99375336 | -166.7917      |
| 21.75           | -14.98337453 | 135.7253       | -51.58492383 | 80.65435       | 20.84540286 | -156.16        | -13.93191213 | 126.4174       |
| 22.00           | -15.0534118  | 132.4365       | -50.65432343 | 70.29443       | 20.79089267 | -163.8192      | -13.80462928 | 50.23223       |
| 22.25           | -15.18069607 | 130.7094       | -51.01217322 | 64.31312       | 20.77090997 | -169.6259      | -13.66911466 | -14.48867      |
| 22.50           | -15.12574012 | 129.0565       | -50.0589988  | 56.86007       | 20.8603409  | -170.5688      | -13.58380875 | -91.78304      |
| 22.75           | -15.08626965 | 128.2232       | -51.74807807 | 55.47022       | 20.81792882 | -172.9285      | -13.7221915  | -152.1783      |
| 23.00           | -14.99602393 | 124.8725       | -51.13032313 | 53.64964       | 20.80876731 | -168.9904      | -13.53672031 | 126.3781       |
| 23.25           | -14.8537183  | 120.3659       | -50.17404016 | 57.88192       | 20.8115805  | -161.4748      | -13.32979145 | 51.83643       |
| 23.50           | -15.36344283 | 116.3281       | -49.045145   | 43.18889       | 20.73456942 | -155.6715      | -13.35741826 | -14.95574      |
| 23.75           | -15.0946598  | 115.1304       | -49.85819483 | 43.34335       | 20.81239514 | -148.4648      | -13.40357247 | -90.19309      |
| 24.00           | -15.39735257 | 112.4639       | -49.72499596 | 32.64002       | 20.75503497 | -142.5701      | -13.4656704  | -152.0927      |
| 24.25           | -15.13095054 | 109.5295       | -50.13093024 | 30.30852       | 20.83643776 | -135.1379      | -13.55071132 | 126.8156       |
| 24.50           | -15.1744339  | 106.0131       | -50.20715943 | 25.31852       | 20.83040005 | -129.3736      | -13.65003675 | 62.67419       |
| 24.75           | -14.87939547 | 100.8113       | -50.50249522 | 26.3597        | 20.89856238 | -121.75        | -13.52521517 | -12.75818      |
| 25.00           | -14.90477717 | 96.33096       | -49.57069959 | 21.51729       | 20.90054564 | -115.4541      | -13.5387876  | -76.76747      |
| 25.25           | -14.67738998 | 91.03966       | -48.74758629 | 21.70694       | 20.89195512 | -108.3276      | -13.57528524 | -150.5746      |
| 25.50           | -14.38830456 | 87.22176       | -49.67421973 | 8.14969        | 20.99917398 | -101.1408      | -13.72233378 | 127.6319       |
| 25.75           | -14.13837685 | 81.97481       | -48.96714338 | 5.585327       | 21.04299246 | -94.48246      | -13.85032041 | 64.45851       |
| 26.00           | -13.68285147 | 75.85893       | -49.1836183  | -3.681355      | 21.12871511 | -87.0444       | -14.05533839 | -10.21604      |
| 26.25           | -13.22837385 | 70.50666       | -50.06582294 | -14.11971      | 21.2527216  | -80.46708      | -14.16774214 | -72.27026      |
| 26.50           | -12.44232727 | 62.4766        | -50.54932781 | -23.09788      | 21.34178196 | -71.82767      | -14.09760141 | -142.9784      |
| 26.75           | -12.1231902  | 55.19888       | -49.5366484  | -9.982013      | 21.34760323 | -65.34277      | -14.12675521 | 142.8106       |
| 27.00           | -11.51541544 | 48.33369       | -49.01919565 | -31.26795      | 21.48924461 | -56.8985       | -14.44884399 | 72.33661       |
| 27.25           | -10.95899259 | 42.02633       | -49.27235222 | -36.02533      | 21.51576377 | -49.67164      | -14.46870091 | 12.9942        |
| 27.50           | -10.17930299 | 33.51711       | -49.83416656 | -45.60722      | 21.56439576 | -40.38253      | -14.03623103 | -61.09192      |
| 27.75           | -9.486668382 | 24.41982       | -50.21434656 | -51.82261      | 21.54985487 | -31.15906      | -14.18198677 | -136.7268      |
| 28.00           | -8.86384684  | 18.61195       | -49.92261375 | -63.95271      | 21.58096768 | -23.28123      | -13.83955787 | 155.505        |
| 28.25           | -8.082733695 | 9.647546       | -52.65291204 | -77.20475      | 21.5193103  | -13.39679      | -13.31467582 | 84.48412       |
| 28.50           | -7.684183764 | 1.679874       | -52.09575618 | -69.46488      | 21.34695902 | -5.231442      | -13.13934105 | 24.31771       |
| 28.75           | -7.134292488 | -5.842427      | -50.43673429 | -76.09734      | 21.24451683 | -4.82478       | -12.71549435 | -46.76101      |
| 29.00           | -6.52197965  | -12.848        | -48.94679421 | -89.84153      | 21.06557481 | -13.77886      | -12.1811325  | -110.1438      |
| 29.25           | -5.998240777 | -22.03921      | -49.27311546 | -105.3236      | 20.72026144 | -23.99692      | -11.4541009  | 164.9588       |
| 29.50           | -5.644587238 | -28.6075       | -48.72771039 | -119.9739      | 20.41443603 | -32.80532      | -10.89193703 | 104.8088       |
| 29.75           | -5.27953438  | -37.44137      | -49.74170856 | -140.7835      | 19.94991228 | -42.83006      | -10.21068599 | 29.38953       |
| 30.00           | -4.941451463 | -44.89988      | -49.85115212 | -150.2209      | 19.44888726 | -52.45927      | -9.575210602 | -48.08296      |
| 30.25           | -4.825257403 | -51.70079      | -51.02755692 | -151.5981      | 18.89354455 | -60.66542      | -9.177802992 | -114.5268      |
| 30.50           | -4.615118041 | -58.4916       | -51.29842096 | -154.4575      | 18.30012391 | -69.80401      | -8.690316302 | 159.8694       |
| 30.75           | -4.44721087  | -63.4305       | -51.03586887 | -157.2381      | 17.75344043 | -76.78794      | -8.348029064 | 96.70776       |
| 31.00           | -4.355991672 | -69.75317      | -50.4634257  | -157.4598      | 17.08638984 | -85.54248      | -7.999071087 | 20.62207       |
| 31.25           | -4.322415263 | -74.47208      | -51.17707418 | -159.6716      | 16.58920074 | -92.28         | -7.750419231 | -45.304        |
| 31.50           | -4.206464968 | -79.78357      | -49.76725044 | -156.0792      | 15.83669567 | -100.0134      | -7.49742569  | -124.8377      |
| 31.75           | -4.173257655 | -83.59286      | -49.13513642 | -141.7404      | 15.33144978 | -106.2723      | -7.376597896 | 163.0723       |
| 32.00           | -4.143739107 | -88.26109      | -49.28087624 | -132.9657      | 14.71038311 | -112.2931      | -7.215566664 | 87.67538       |

**ADVANCED:** Data Sheets contain information regarding a product M/A-COM Technology Solutions is considering for development. Performance is based on target specifications, simulated results, and/or prototype measurements. Commitment to develop is not guaranteed.

**PRELIMINARY:** Data Sheets contain information regarding a product M/A-COM Technology Solutions has under development. Performance is based on engineering tests. Specifications are typical. Mechanical outline has been fixed. Engineering samples and/or test data may be available. Commitment to produce in volume is not guaranteed.

• **North America** Tel: 800.366.2266 • **Europe** Tel: +353.21.244.6400  
• **India** Tel: +91.80.43537383 • **China** Tel: +86.21.2407.1588

Visit [www.macomtech.com](http://www.macomtech.com) for additional data sheets and product information.

M/A-COM Technology Solutions and its affiliates reserve the right to make changes to the products or information contained herein without notice.



# XB1004-BD



**Buffer Amplifier**  
**16.0-30.0 GHz**

Rev. V1  
MimiX Broadband

## Mechanical Drawing

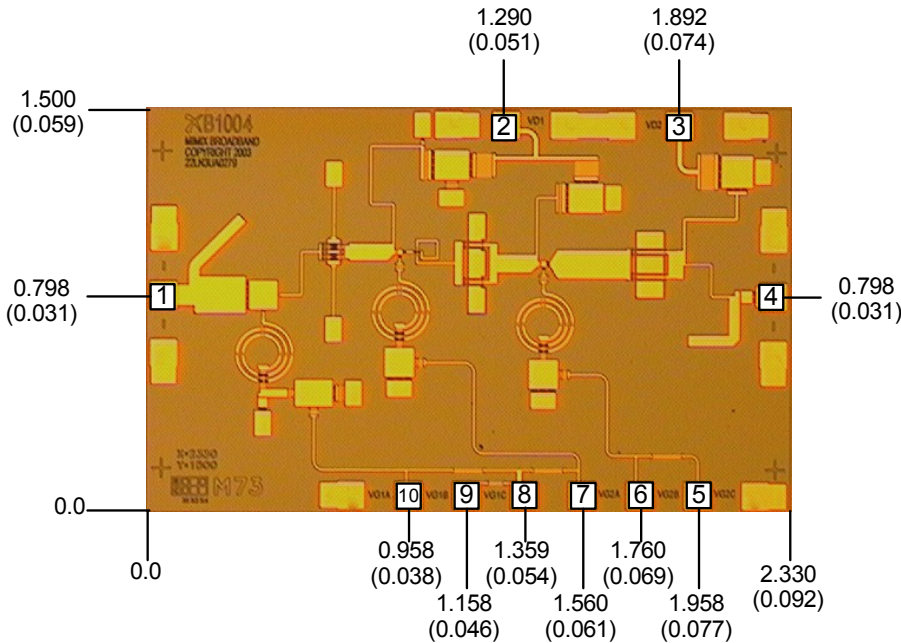

(Note: Engineering designator is 22LN3UA0279)

Units: millimeters (inches) Bond pad dimensions are shown to center of bond pad.  
 Thickness: 0.110 +/- 0.010 (0.0043 +/- 0.0004), Backside is ground, Bond Pad/Backside Metallization: Gold  
 All Bond Pads are 0.100 x 0.100 (0.004 x 0.004).  
 Bond pad centers are approximately 0.109 (0.004) from the edge of the chip.  
 Dicing tolerance: +/- 0.005 (+/- 0.0002). Approximate weight: 2.165 mg.

- |                     |                      |                    |                    |                     |
|---------------------|----------------------|--------------------|--------------------|---------------------|
| Bond Pad #1 (RF In) | Bond Pad #3 (Vd2)    | Bond Pad #5 (Vg2c) | Bond Pad #7 (Vg2a) | Bond Pad #9 (Vg1b)  |
| Bond Pad #2 (Vd1)   | Bond Pad #4 (RF Out) | Bond Pad #6 (Vg2b) | Bond Pad #8 (Vg1c) | Bond Pad #10 (Vg1a) |

## Bias Arrangement

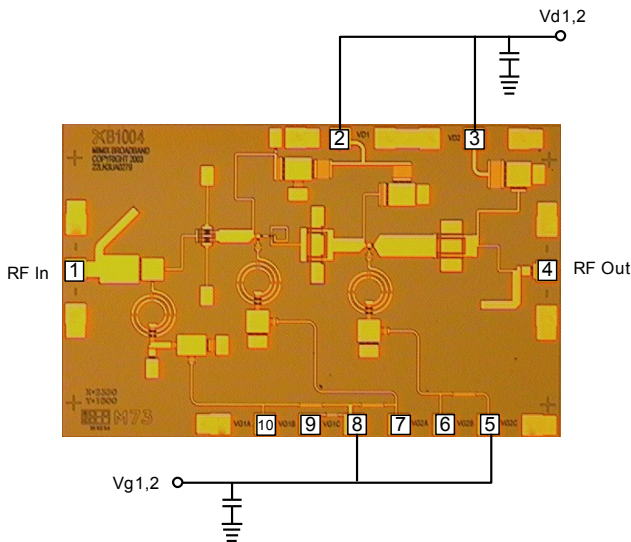

Bypass Capacitors - See App Note [2]

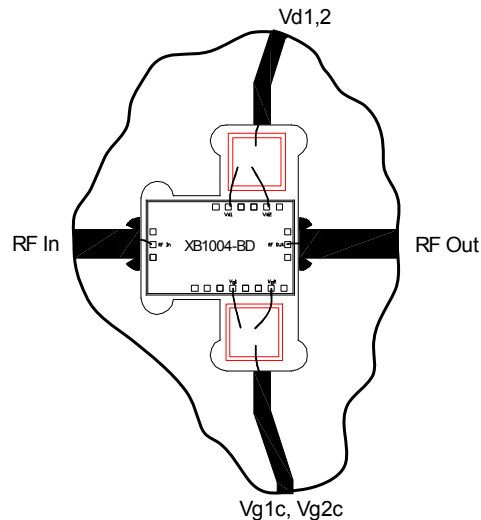



# XB1004-BD



**Buffer Amplifier**  
**16.0-30.0 GHz**

Rev. V1  
MimiX Broadband

## MTTF Tables

These numbers were calculated based on accelerated life test information and thermal model analysis received from the fabricating foundry.

| Backplate Temperature | Channel Temperature | Rth       | MTTF Hours | FITs     |
|-----------------------|---------------------|-----------|------------|----------|
| 55 deg Celsius        | 83.4 deg Celsius    | 78.8° C/W | 5.36E+10   | 1.87E-02 |
| 75 deg Celsius        | 105.5 deg Celsius   | 84.7° C/W | 3.52E+09   | 2.84E-01 |
| 95 deg Celsius        | 127.4 deg Celsius   | 90.0° C/W | 3.206E+08  | 3.13E+00 |

Bias Conditions: Vd1=Vd2=4.0V, Id1=45 mA, Id2=45 mA

| Backplate Temperature | Channel Temperature | Rth       | MTTF Hours | FITs     |
|-----------------------|---------------------|-----------|------------|----------|
| 55 deg Celsius        | 108.3 deg Celsius   | 76.1° C/W | 2.56E+09   | 3.91E-01 |
| 75 deg Celsius        | 132.1 deg Celsius   | 81.5° C/W | 1.992E+08  | 5.04E+00 |
| 95 deg Celsius        | 155.5 deg Celsius   | 86.4° C/W | 2.12E+07   | 4.72E+01 |

Bias Conditions: Vd1=Vd2=5.0V, Id1=70 mA, Id2=70 mA

| Backplate Temperature | Channel Temperature | Rth       | MTTF Hours | FITs     |
|-----------------------|---------------------|-----------|------------|----------|
| 55 deg Celsius        | 138.1 deg Celsius   | 77.0° C/W | 1.08E+08   | 9.22E-00 |
| 75 deg Celsius        | 163.7 deg Celsius   | 82.1° C/W | 1.02E+07   | 9.82E+01 |
| 95 deg Celsius        | 188.8 deg Celsius   | 86.8° C/W | 1.29E+06   | 7.73E+02 |

Bias Conditions: Vd1=Vd2=6.0V, Id1=90 mA, Id2=90 mA

**App Note [1] Biasing** - As shown in the bonding diagram, this device can be operated with all three stages in parallel, and can be biased for low noise performance or high power performance. Low noise bias is nominally  $V_d=4V$ ,  $I_d=90mA$ . More controlled performance will be obtained by separately biasing  $V_{d1}$  and  $V_{d2}$  each at  $4.0V$ ,  $45mA$ . Power bias may be as high as  $V_d=6.0V$ ,  $I_d=180mA$  with all stages in parallel, or most controlled performance will be obtained by separately biasing  $V_{d1}$  and  $V_{d2}$  each at  $6.0V$ ,  $90mA$ . It is also recommended to use active biasing to keep the currents constant as the RF power and temperature vary; this gives the most reproducible results. Depending on the supply voltage available and the power dissipation constraints, the bias circuit may be a single transistor or a low power operational amplifier, with a low value resistor in series with the drain supply used to sense the current. The gate of the pHEMT is controlled to maintain correct drain current and thus drain voltage. The typical gate voltage needed to do this is  $-0.3V$ . Typically the gate is protected with Silicon diodes to limit the applied voltage. Also, make sure to sequence the applied voltage to ensure negative gate bias is available before applying the positive drain supply.

### App Note [2] Bias Arrangement -

For Parallel Stage Bias (Recommended for general applications) -- The same as Individual Stage Bias but all the drain or gate pad DC bypass capacitors ( $\sim 100-200$  pf) can be combined. The suggested configuration is to connect  $V_{d1,2}$  and  $V_{g1c,2c}$ . Additional DC bypass capacitance ( $\sim 0.01$  uF) is also recommended to all DC or combination (if gate or drains are tied together) of DC bias pads.

For Individual Stage Bias (Low Input Drive applications only) -- Each DC pad ( $V_{d1,2}$  and  $V_{g1a,2a,2b}$ ) needs to have DC bypass capacitance ( $\sim 100-200$  pf) as close to the device as possible. Additional DC bypass capacitance ( $\sim 0.01$  uF) is also recommended.

For Individual Stage Bias (High Input Drive applications only) -- Each DC pad ( $V_{d1,2}$  and  $V_{g1c,2c}$ ) needs to have DC bypass capacitance ( $\sim 100-200$  pf) as close to the device as possible. Additional DC bypass capacitance ( $\sim 0.01$  uF) is also recommended.

## Device Schematic

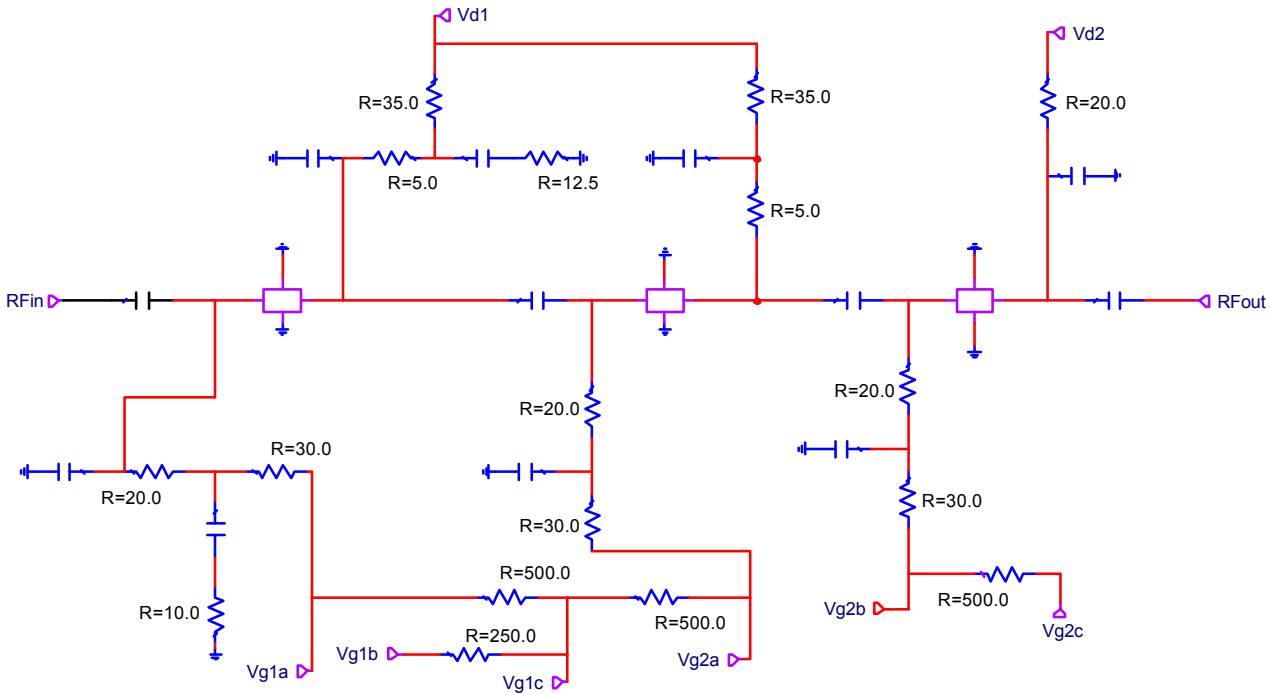

## Typical Application

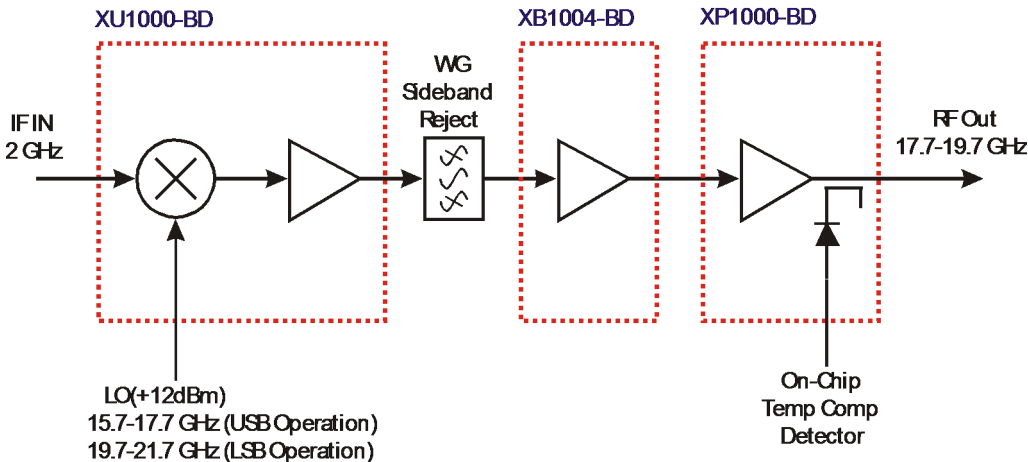

**M/A-COM Tech MMIC-based 17.0-27.0 GHz Transmitter Block Diagram**  
(Changing LO and IF frequencies as required allows design to operate as high as 27 GHz)

# XB1004-BD



**Buffer Amplifier**  
**16.0-30.0 GHz**

Rev. V1  
MimiX Broadband

## Handling Procedures

Please observe the following precautions to avoid damage:

## Static Sensitivity

Gallium Arsenide Integrated Circuits are sensitive to electrostatic discharge (ESD) and can be damaged by static electricity. Proper ESD control techniques should be used when handling these class 2 devices.