

CM35MX-24A

HIGH POWER SWITCHING USE

CM35MX-24A



- Ic 35A
- VCES 1200V
- CIB (3-phase Converter + 3-phase Inverter + Brake)
- Flatbase Type / Insulated Package / Copper base plate
- RoHS Directive compliant

APPLICATION

General purpose Inverters, Servo Amplifiers

OUTLINE DRAWING & CIRCUIT DIAGRAM

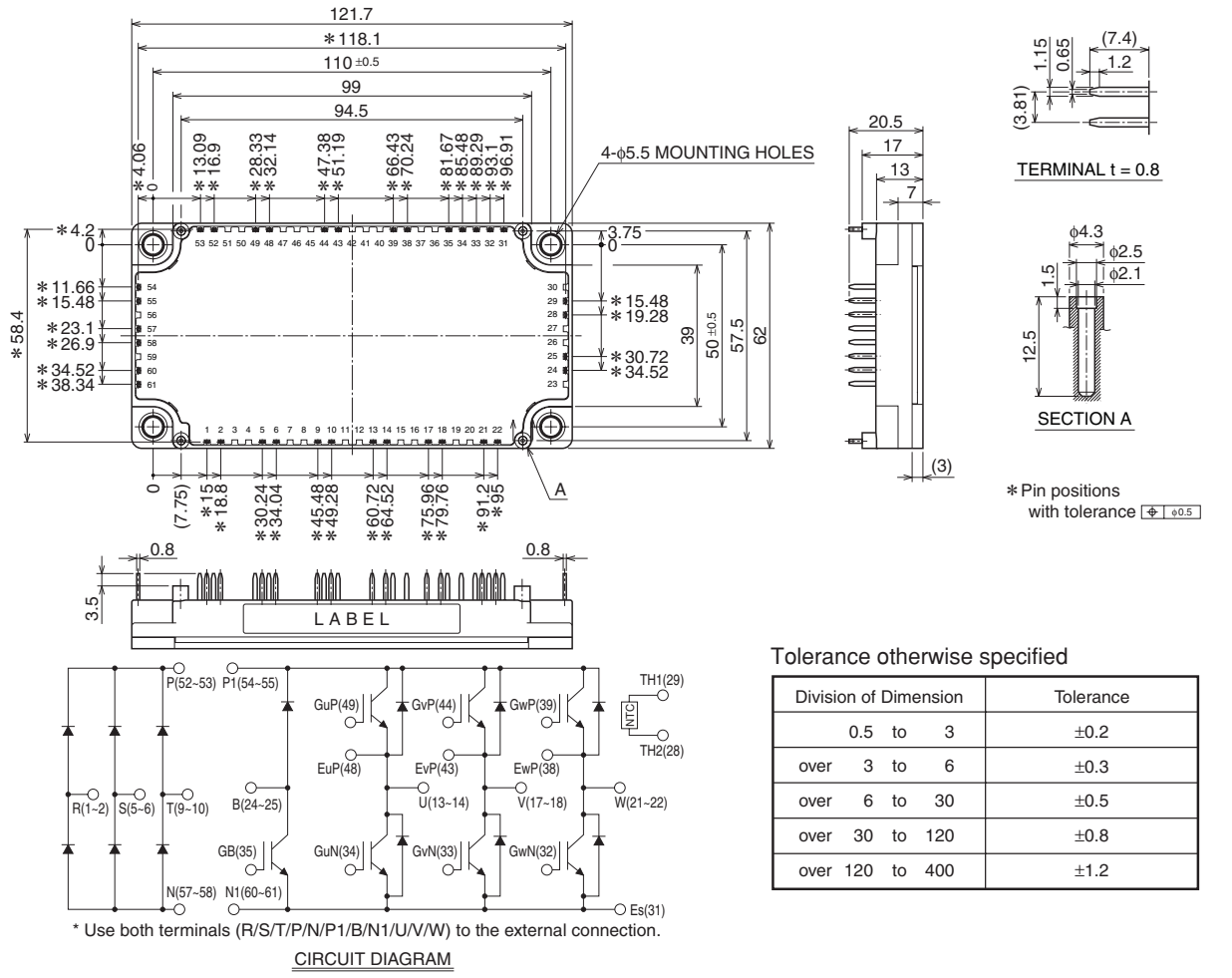

CM35MX-24A

HIGH POWER SWITCHING USE

ABSOLUTE MAXIMUM RATINGS (T_j = 25°C, unless otherwise specified)

INVERTER PART

Symbol	Parameter	Conditions	Rating	Unit
V _{CES}	Collector-emitter voltage	G-E Short	1200	V
V _{GES}	Gate-emitter voltage	C-E Short	±20	
I _C	Collector current	DC, T _c = 105°C (Note. 1)	35	A
I _{CRM}		Pulse (Note. 4)	70	
P _{q c}	Maximum collector dissipation	T _c = 25°C (Note. 1, 5)	295	W
I _E (Note.3)	Emitter current	T _c = 25°C (Note. 1)	35	A
I _{ERM} (Note.3)	(Free wheeling diode forward current)	Pulse (Note. 4)	70	

BRAKE PART

Symbol	Parameter	Conditions	Rating	Unit
V _{CES}	Collector-emitter voltage	G-E Short	1200	V
V _{GES}	Gate-emitter voltage	C-E Short	±20	
I _C	Collector current	DC, T _c = 121°C (Note. 1)	20	A
I _{CRM}		Pulse (Note. 4)	40	
P _{q c}	Maximum collector dissipation	T _c = 25°C (Note. 1, 5)	260	W
V _{RRM} (Note.3)	Repetitive peak reverse voltage		1200	V
I _F (Note.3)	Forward current	T _c = 25°C (Note. 1)	20	A
I _{FRM} (Note.3)		Pulse (Note. 4)	40	

CONVERTER PART

Symbol	Parameter	Conditions	Rating	Unit
V _{RRM}	Repetitive peak reverse voltage		1600	V
E _a	Recommended AC input voltage		440	V
I _o	DC output current	3-phase full wave rectifying, T _c = 105°C (Note. 1)	35	A
I _{FSM}	Surge forward current	The sine half wave 1 cycle peak value, f = 60Hz, non-repetitive	350	
i ² t	Current square time	Value for one cycle of surge current	510	A ² s

MODULE

Symbol	Parameter	Conditions	Rating	Unit
T _j	Junction temperature		-40 ~ +150	°C
T _{stg}	Storage temperature		-40 ~ +125	
V _{iso}	Isolation voltage	Terminals to base plate, f = 60Hz, AC 1 min (Note. 8)	2500	V
—	Base plate flatness	On the centerline X, Y (Note. 8)	±0 ~ +100	μm
—	Torque	Mounting M5 screw	2.5 ~ 3.5	N·m
—	Weight	(Typical)	270	g

Note. 8: The base plate flatness measurement points are in the following figure.

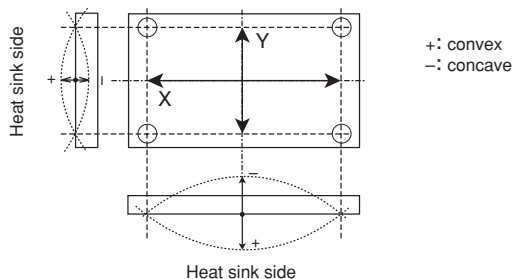

CM35MX-24A

HIGH POWER SWITCHING USE

ELECTRICAL and THERMAL RESISTANCE CHARACTERISTICS (T_j = 25°C, unless otherwise specified)

INVERTER PART

Symbol	Parameter	Conditions	Limits			Unit	
			Min.	Typ.	Max.		
ICES	Collector cut-off current	VCE = VCES, G-E Short	—	—	1	mA	
VGE(th)	Gate-emitter threshold voltage	IC = 3.5mA, VCE = 10V	6	7	8	V	
IGES	Gate leakage current	VGE = VGES, C-E Short	—	—	0.5	μA	
VCEsat	Collector-emitter saturation voltage	IC = 35A, VGE = 15V (Note. 6)	T _j = 25°C	—	2.0	2.6	V
			T _j = 125°C	—	2.2	—	
		IC = 35A, VGE = 15V	Chip	—	1.9	—	
Cies	Input capacitance	VCE = 10V G-E Short (Note. 6)	—	—	6.0	nF	
Coes	Output capacitance		—	—	0.53		
Cres	Reverse transfer capacitance		—	—	0.12		
QG	Gate charge	VCC = 600V, IC = 35A, VGE = 15V	—	180	—	nC	
td(on)	Turn-on delay time	VCC = 600V, IC = 35A	—	—	100	ns	
tr	Rise time	VGE = ±15V, RG = 9.1Ω	—	—	50		
td(off)	Turn-off delay time	Inductive load	—	—	300		
tf	Fall time		—	—	600		
trr (Note.3)	Reverse recovery time		(IE = 35A)	—	—		200
Qrr (Note.3)	Reverse recovery charge		—	1.5	—	μC	
VEC(Note.3)	Emitter-collector voltage	IE = 35A, G-E Short (Note. 6)	T _j = 25°C	—	2.6	3.4	V
			T _j = 125°C	—	2.16	—	
		IE = 35A, G-E Short	Chip	—	2.5	—	
Rth(j-c)Q	Thermal resistance (Junction to case) (Note. 1)	per IGBT	—	—	0.42	K/W	
Rth(j-c)D		per free wheeling diode	—	—	0.69		
l*	Internal gate resistance	Tc = 25°C, per switch	—	0	—	Ω	
RG	External gate resistance		8.9	—	89		

BRAKE PART

Symbol	Parameter	Conditions	Limits			Unit	
			Min.	Typ.	Max.		
ICES	Collector cut-off current	VCE = VCES, VGE = 0V	—	—	1	mA	
VGE(th)	Gate-emitter threshold voltage	IC = 2mA, VCE = 10V	6	7	8	V	
IGES	Gate leakage current	VGE = VGES, VCE = 0V	—	—	0.5	μA	
VCEsat	Collector-emitter saturation voltage	IC = 20A, VGE = 15V (Note. 6)	T _j = 25°C	—	2.0	2.6	V
			T _j = 125°C	—	2.2	—	
		IC = 20A, VGE = 15V	Chip	—	1.9	—	
Cies	Input capacitance	VCE = 10V VGE = 0V (Note. 6)	—	—	5.1	nF	
Coes	Output capacitance		—	—	0.45		
Cres	Reverse transfer capacitance		—	—	0.1		
QG	Gate charge	VCC = 600V, IC = 20A, VGE = 15V	—	150	—	nC	
IRRM(Note.3)	Repetitive peak reverse current	VR = VRRM	—	—	1	mA	
VF(Note.3)	Forward voltage	IF = 20A (Note. 6)	T _j = 25°C	—	2.6	3.4	V
			T _j = 125°C	—	2.16	—	
		IF = 20A	Chip	—	2.5	—	
Rth(j-c)Q	Thermal resistance (Junction to case) (Note. 1)	per IGBT	—	—	0.48	K/W	
Rth(j-c)D		per Clamp diode	—	—	1.1		
l*	Internal gate resistance	Tc = 25°C	—	0	—	Ω	
RG	External gate resistance		15	—	150		

CONVERTER PART

Symbol	Parameter	Conditions	Limits			Unit
			Min.	Typ.	Max.	
IRRM	Repetitive peak reverse current	VR = VRRM, T _j = 150°C	—	—	4	mA
VF	Forward voltage	IF = 35A	—	1.2	1.6	V
Rth(j-c)	Thermal resistance (Junction to case) (Note. 1)	per Diode	—	—	0.45	K/W

CM35MX-24A

HIGH POWER SWITCHING USE

NTC THERMISTOR PART

Symbol	Parameter	Conditions	Limits			Unit
			Min.	Typ.	Max.	
R _g	Zero power resistance	T _c = 25°C	4.85	5.00	5.15	kΩ
ΔR/R	Deviation of resistance	T _c = 100°C, R ₁₀₀ = 493Ω	-7.3	—	+7.8	%
B _(25/50)	B constant	Approximate by equation (Note. 7)	—	3375	—	K
P ₂₅	Power dissipation	T _c = 25°C	—	—	10	mW

MODULE

Symbol	Parameter	Conditions	Limits			Unit
			Min.	Typ.	Max.	
R _{th(c-*)}	Contact thermal resistance (Case to θ_{cs} in) (Note. 1)	Thermal grease applied per 1 module (Note. 2)	—	0.015	—	K/W

- Note. 1: Case temperature (T_c), heat sink temperature (T_{*}) measured point is just under the chips. (Refer to the figure of the chip location.)
 2: Typical value is measured by using thermally conductive grease of λ = 0.9W/(m·K).
 3: I_E, I_{ERM}, V_{EC}, t_r, Q_{rr} and E_{rr} represent ratings and characteristics of the anti-parallel, emitter-collector free wheeling diode (FWDi).
 I_F, I_{FRM}, V_F, V_{RRM} and I_{RRM} represent ratings and characteristics of the Clamp diode of Brake part.
 4: Pulse width and repetition rate should be such that the device junction temperature (T_j) dose not exceed T_{jmax} rating.
 5: Junction temperature (T_j) should not increase beyond 150°C.
 6: Pulse width and repetition rate should be such as to cause negligible temperature rise.
 (Refer to the figure of the test circuit for V_{CEsat} and V_{EC})
 7: $B_{(25/50)} = \ln\left(\frac{R_{25}}{R_{50}}\right) / \left(\frac{1}{T_{25}} - \frac{1}{T_{50}}\right)$
 R₂₅: resistance at absolute temperature T₂₅ [K]; T₂₅ = 25 [°C]+273.15 = 298.15 [K]
 R₅₀: resistance at absolute temperature T₅₀ [K]; T₅₀ = 50 [°C]+273.15 = 323.15 [K]

Chip Location (Top view)

Dimensions in mm (tolerance: ±1mm)

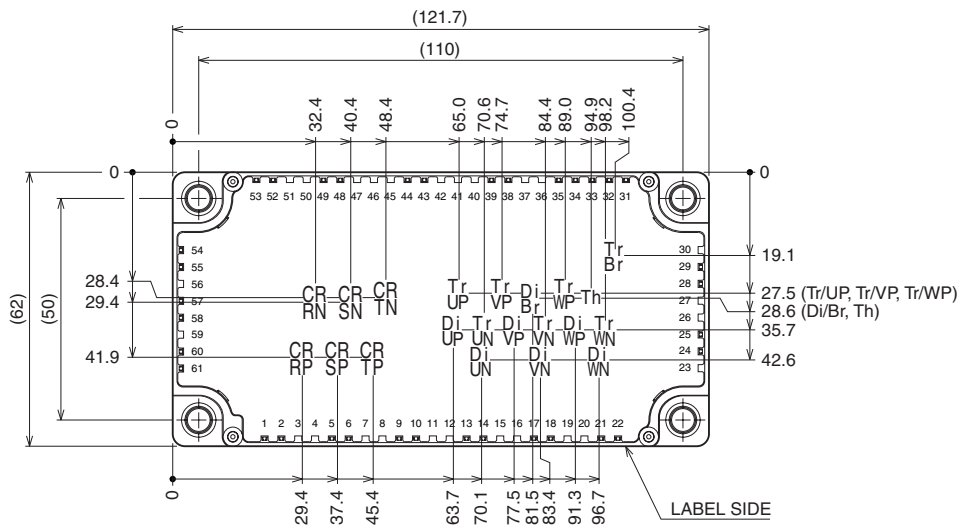

Each mark points the center position of each chip. Tr**: IGBT, Di**: FWDi (DiBr: Clamp diode), CR**: Converter diode, Th: NTC thermistor

CM35MX-24A

HIGH POWER SWITCHING USE

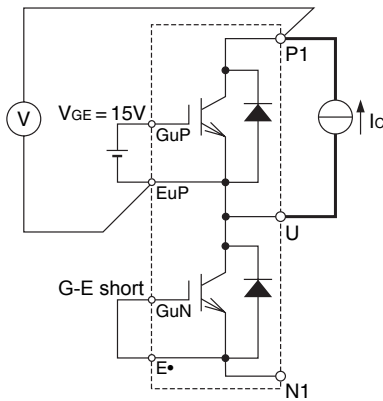

P side Inverter part Tr
(example of U arm)
G-E short
(GvP-EvP, GwP-EwP, GvN-Es, GwN-Es, GB-Es) (GvP-EvP, GwP-EwP, GvN-Es, GwN-Es, GB-Es)

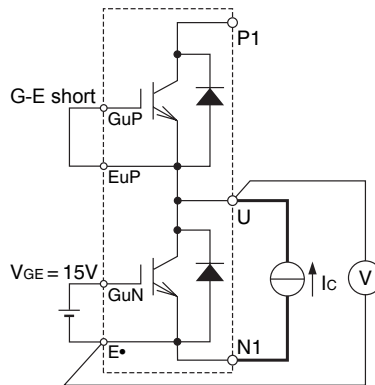

N side Inverter part Tr
(example of U arm)
G-E short

VCEsat test circuit

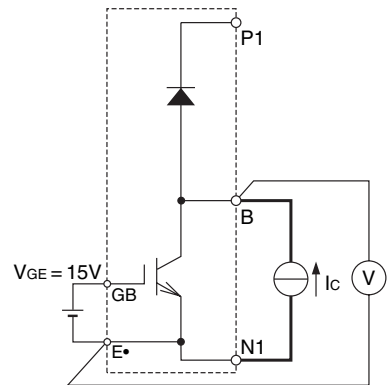

Br Tr
G-E short
(GuP-EuP, GvP-EvP, GwP-EwP, GuN-Es, GvN-Es, GwN-Es)

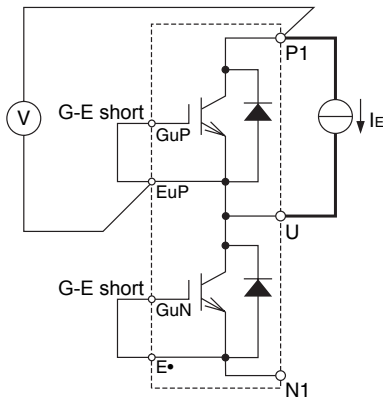

P side Inverter part Di
(example of U arm)
G-E short
(GvP-EvP, GwP-EwP, GvN-Es, GwN-Es, GB-Es) (GvP-EvP, GwP-EwP, GvN-Es, GwN-Es, GB-Es)

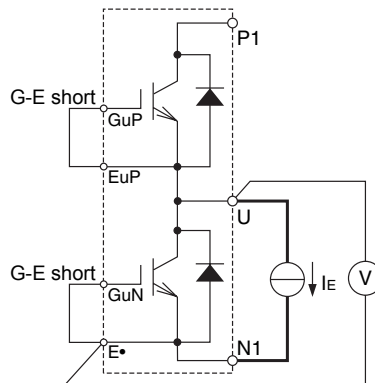

N side Inverter part Di
(example of U arm)
G-E short

VEC/VF test circuit

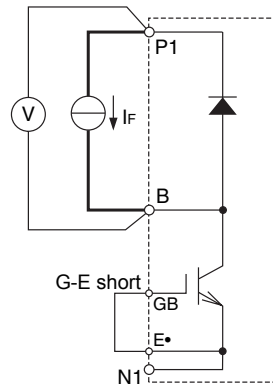

Br Di
G-E short
(GuP-EuP, GvP-EvP, GwP-EwP, GuN-Es, GvN-Es, GwN-Es)

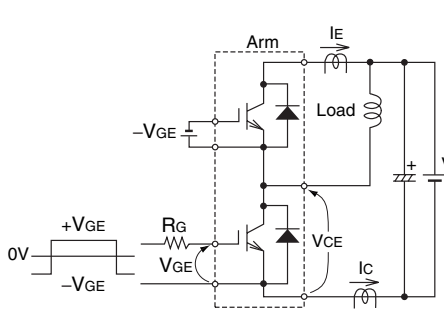

Switching time test circuit and waveforms

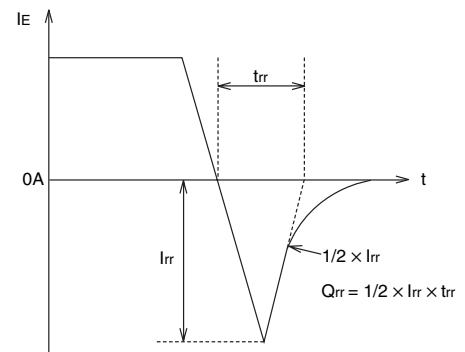
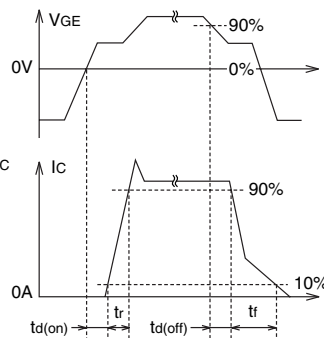

trr, Qrr test waveform

CM35MX-24A

HIGH POWER SWITCHING USE

PERFORMANCE CURVES

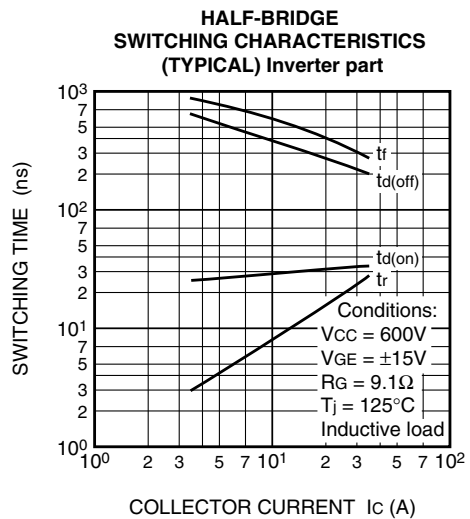
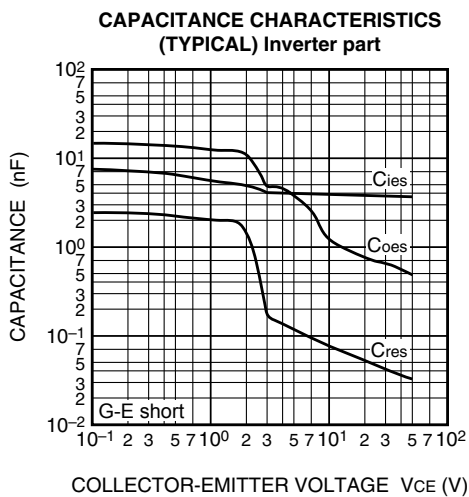
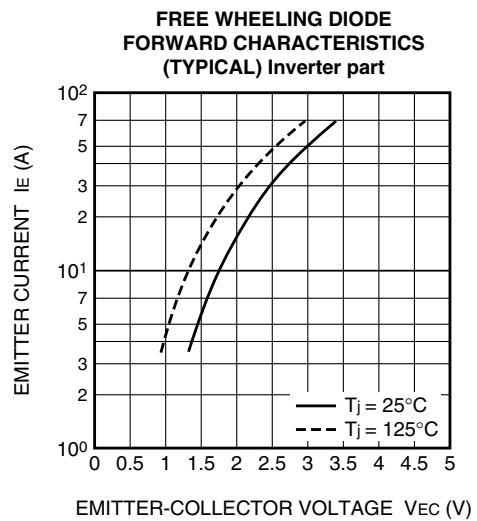
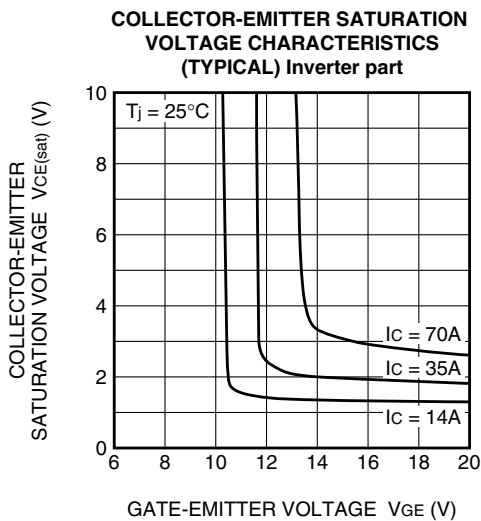
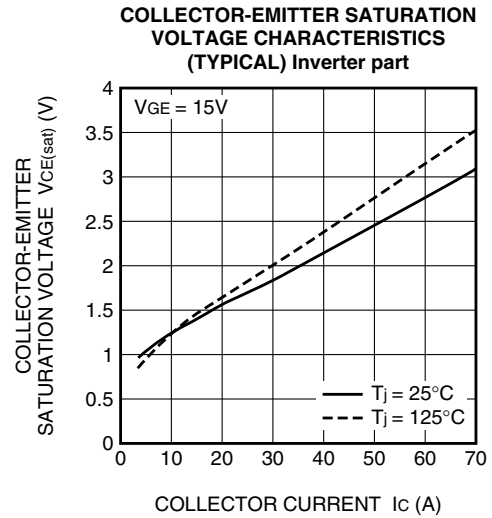
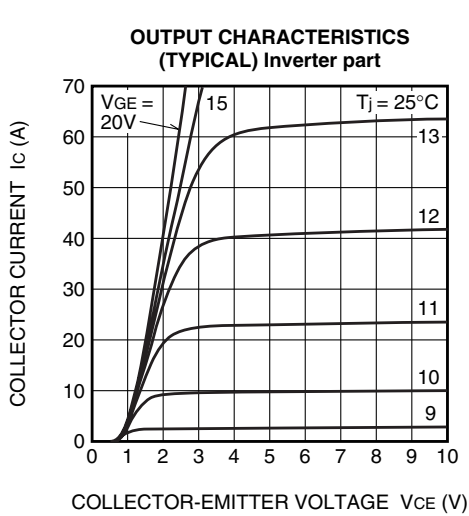

CM35MX-24A

HIGH POWER SWITCHING USE

HALF-BRIDGE SWITCHING CHARACTERISTICS (TYPICAL) Inverter part

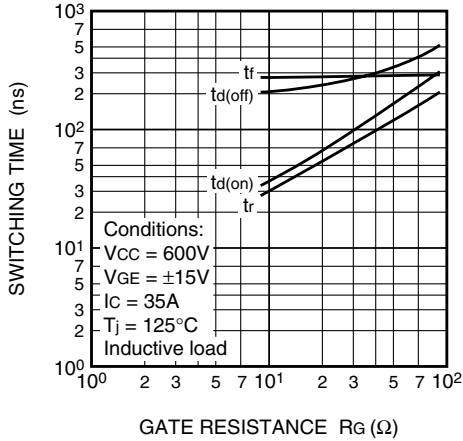

HALF-BRIDGE SWITCHING CHARACTERISTICS (TYPICAL) Inverter part

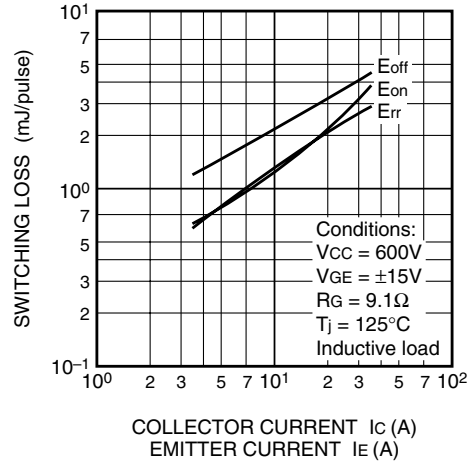

HALF-BRIDGE SWITCHING CHARACTERISTICS (TYPICAL) Inverter part

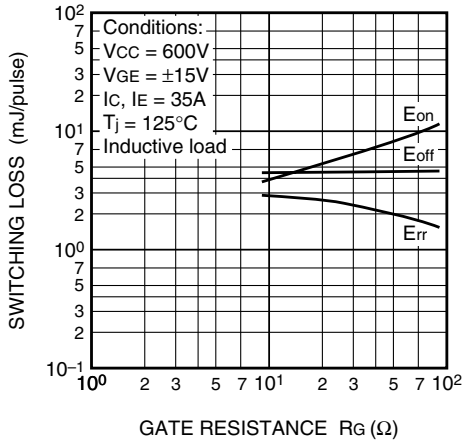

REVERSE RECOVERY CHARACTERISTICS OF FREE WHEELING DIODE (TYPICAL) Inverter part

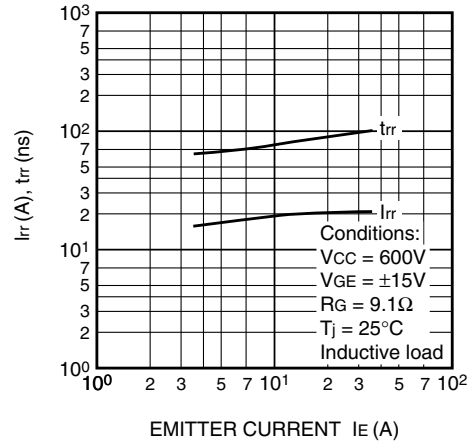

GATE CHARGE CHARACTERISTICS (TYPICAL) Inverter part

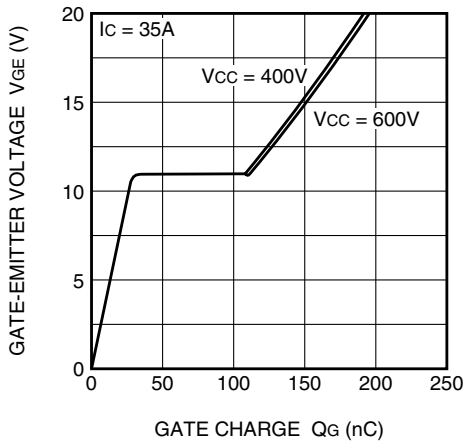

TRANSIENT THERMAL IMPEDANCE CHARACTERISTICS

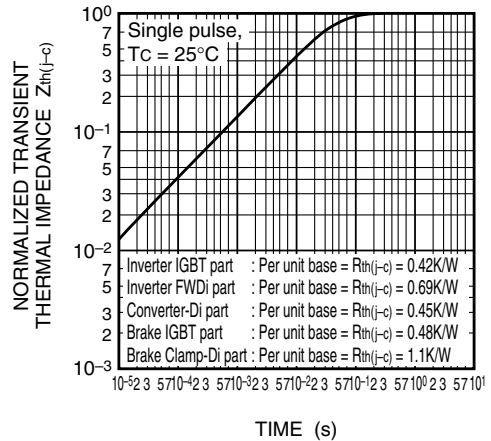

CM35MX-24A

HIGH POWER SWITCHING USE

**RECTIFIER DIODE
FORWARD CHARACTERISTICS
(TYPICAL) Converter part**

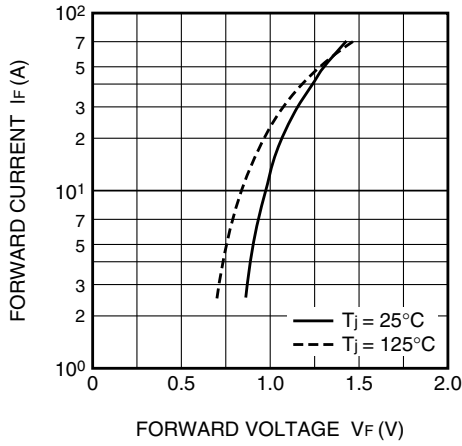

**COLLECTOR-EMITTER SATURATION
VOLTAGE CHARACTERISTICS
(TYPICAL) Brake part**

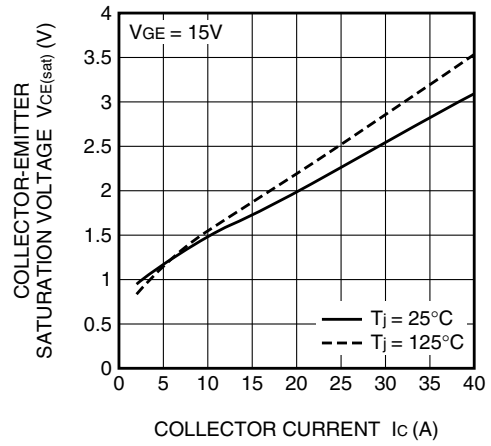

**CLAMP DIODE
FORWARD CHARACTERISTICS
(TYPICAL) Brake part**

