

< C band internally matched power GaAs FET >

MGFC47A7785

7.7 – 8.5 GHz BAND / 47W

DESCRIPTION

The MGFC47A7785 is an internally impedance-matched GaAs power FET especially designed for use in 7.7 – 8.5 GHz band amplifiers. The hermetically sealed metal-ceramic package guarantees high reliability.

FEATURES

Class A operation
Internally matched to 50(ohm) system

- High output power
P1dB=46.7dBm (TYP.) @f=7.7 – 8.5GHz
- High power gain
GLP=5.7dB (TYP.) @f=7.7 – 8.5GHz
- High power added efficiency
PAE=30% (TYP.) @f=7.7 – 8.5GHz

APPLICATION

- Solid-state power amplifier for satellite earth-station communication transmitter and VSAT

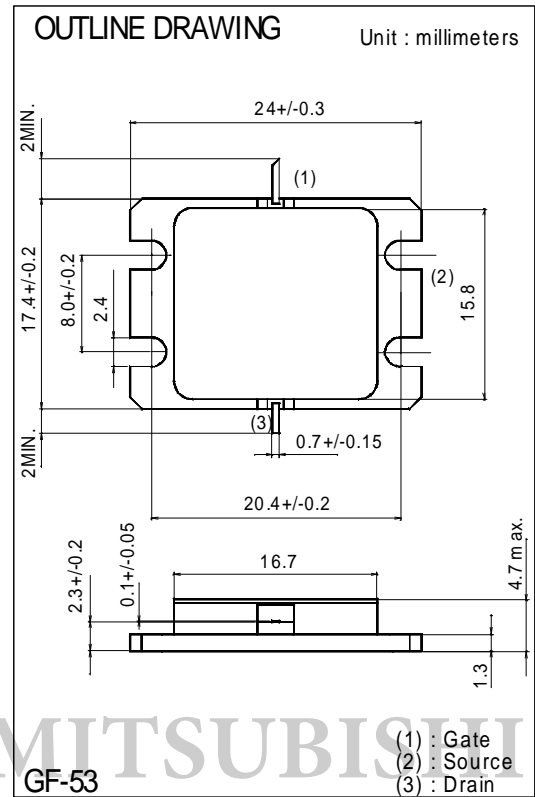

RECOMMENDED BIAS CONDITIONS

- VDS=10V • ID=9.8A • RG=10ohm

Absolute maximum ratings (Ta=25°C)

Symbol	Parameter	Ratings	Unit
VGDO	Gate to drain breakdown voltage	-20	V
VGSO	Gate to source breakdown voltage	-10	V
IGR	Reverse gate current	-130	mA
IGF	Forward gate current	168	mA
PT *1	Total power dissipation	168	W
Tch	Channel temperature	175	°C
Tstg	Storage temperature	-65 to +175	°C

*1 : Tc=25°C

Electrical characteristics (Ta=25°C)

Symbol	Parameter	Test conditions	Limits			Unit
			Min.	Typ.	Max.	
VGS(off)	Gate to source cut-off voltage	VDS=3V, ID=168mA	-1	-	-4	V
P1dB	Output power at 1dB gain compression	IDS=10V, ID(RF off)=9.8A	45.7	46.7	-	dBm
GLP	Linear Power Gain	f=7.7 – 8.5GHz	4.7	5.7	-	dB
ID	Drain current		-	11	-	A
PAE	Power added efficiency		-	30	-	%
IM3*2	3rd order IM distortion		-39	-42	-	dBc
Rth(ch-c) *3	Thermal resistance	delta Vf method	-	0.8	0.9	°C/W

*2 : Item -51, 2 tone test, Po=35dBm Single Carrier Level, f=8.5GHz, Delta f=10MHz

*3 : Channel-case

Keep Safety first in your circuit designs!
Mitsubishi Electric Corporation puts the maximum effort into making semiconductor products better and more reliable, but there is always the possibility that trouble may occur with them. Trouble with semiconductors may lead to personal injury, fire or property damage. Remember to give due consideration to safety when making your circuit designs, with appropriate measure such as (i) placement of substitutive, auxiliary circuits, (ii) use of non-flammable material or (iii) prevention against any malfunction or mishap.

MGFC47A7785

7.7 – 8.5 GHz BAND / 47W

MGFC47A5864 S-parameters(Ta=25deg.C , VDS=10(V),IDS=8(A))

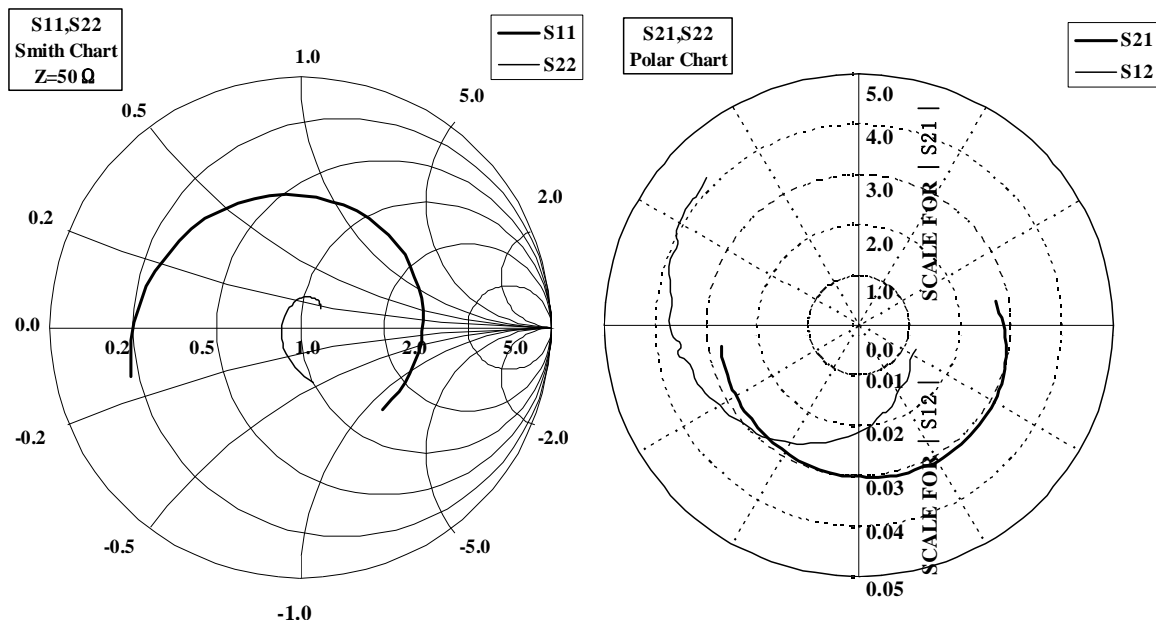

www.BDTIC.com/MITSUBISHI

f (GHz)	S Parameters(TYP.)							
	S11		S21		S12		S22	
	MAG.	ANG(deg.)	[MAG]	[ANG]	[MAG]	[ANG]	[MAG]	[ANG]
5.60	0.702	-163.8	2.723	10.1	0.024	-23.0	0.225	-76.8
5.65	0.676	-175.6	2.836	0.3	0.027	-42.2	0.194	-86.4
5.70	0.646	171.6	2.932	-9.7	0.030	-57.8	0.164	-97.8
5.75	0.621	158.6	3.011	-19.8	0.036	-71.4	0.132	-111.2
5.80	0.595	144.8	3.072	-30.0	0.040	-82.1	0.106	-129.1
5.85	0.576	131.1	3.091	-40.0	0.044	-95.0	0.087	-148.9
5.90	0.556	116.8	3.108	-49.8	0.049	-105.8	0.077	-175.9
5.95	0.540	102.9	3.111	-59.5	0.053	-117.2	0.075	158.2
6.00	0.528	89.8	3.082	-69.1	0.056	-126.1	0.083	135.8
6.05	0.518	76.5	3.061	-78.5	0.059	-135.8	0.090	119.1
6.10	0.514	64.2	3.033	-87.4	0.062	-144.8	0.102	106.2
6.15	0.510	51.9	2.999	-96.3	0.066	-153.7	0.110	97.2
6.20	0.508	40.5	2.961	-104.9	0.068	-162.2	0.118	87.5
6.25	0.502	29.4	2.933	-113.6	0.072	-170.7	0.125	81.7
6.30	0.498	18.8	2.888	-121.8	0.074	-177.0	0.126	74.6
6.35	0.493	8.4	2.859	-130.1	0.074	174.0	0.128	68.4
6.40	0.486	-2.0	2.817	-138.4	0.076	166.5	0.130	62.4
6.45	0.483	-11.9	2.793	-146.5	0.078	158.4	0.129	57.7
6.50	0.473	-22.4	2.770	-154.6	0.081	152.1	0.126	52.8
6.55	0.471	-33.0	2.751	-163.1	0.082	144.0	0.120	48.6
6.60	0.463	-44.9	2.727	-171.4	0.084	135.6	0.111	44.0

This S-Parameter data show measurements performed on each single-ended FET

Keep safety first in your circuit designs!

Mitsubishi Electric Corporation puts the maximum effort into making semiconductor products better and more reliable, but there is always the possibility that trouble may occur with them. Trouble with semiconductors may lead to personal injury, fire or property damage. Remember to give due consideration to safety when making your circuit designs, with appropriate measures such as (i) placement of substitutive, auxiliary circuits, (ii) use of non-flammable material or (iii) prevention against any malfunction or mishap.

Notes regarding these materials

- These materials are intended as a reference to assist our customers in the selection of the Mitsubishi semiconductor product best suited to the customer's application; they do not convey any license under any intellectual property rights, or any other rights, belonging to Mitsubishi Electric Corporation or a third party.
- Mitsubishi Electric Corporation assumes no responsibility for any damage, or infringement of any third-party's rights, originating in the use of any product data, diagrams, charts, programs, algorithms, or circuit application examples contained in these materials.
- All information contained in these materials, including product data, diagrams, charts, programs and algorithms represents information on products at the time of publication of these materials, and are subject to change by Mitsubishi Electric Corporation without notice due to product improvements or other reasons. It is therefore recommended that customers contact Mitsubishi Electric Corporation or an authorized Mitsubishi Semiconductor product distributor for the latest product information before purchasing a product listed herein.

The information described here may contain technical inaccuracies or typographical errors. Mitsubishi Electric Corporation assumes no responsibility for any damage, liability, or other loss rising from these inaccuracies or errors.

Please also pay attention to information published by Mitsubishi Electric Corporation by various means, including the Mitsubishi Semiconductor home page (<http://www.MitsubishiElectric.com/>).

- When using any or all of the information contained in these materials, including product data, diagrams, charts, programs, and algorithms, please be sure to evaluate all information as a total system before making a final decision on the applicability of the information and products. Mitsubishi Electric Corporation assumes no responsibility for any damage, liability or other loss resulting from the information contained herein.
- Mitsubishi Electric Corporation semiconductors are not designed or manufactured for use in a device or system that is used under circumstances in which human life is potentially at stake. Please contact Mitsubishi Electric Corporation or an authorized Mitsubishi Semiconductor product distributor when considering the use of a product contained herein for any specific purposes, such as apparatus or systems for transportation, vehicular, medical, aerospace, nuclear, or undersea repeater use.
- The prior written approval of Mitsubishi Electric Corporation is necessary to reprint or reproduce in whole or in part these materials.
- If these products or technologies are subject to the Japanese export control restrictions, they must be exported under a license from the Japanese government and cannot be imported into a country other than the approved destination.
Any diversion or re-export contrary to the export control laws and regulations of Japan and/or the country of destination is prohibited.
- Please contact Mitsubishi Electric Corporation or an authorized Mitsubishi Semiconductor product distributor for further details on these materials or the products contained therein.