

Package Style: QFN, 6-pin, 2mmx1.3mmx0.35mm



Features

- Broadband Performance
Low Frequency to 5.8GHz
- Very Low Insertion Loss
0.26dB Typ at 1GHz
0.32dB Typ at 2GHz
- Excellent Harmonics <-75 dBc
at 2GHz
- High IIP₃: Cell Band Typ.
62dBm
- 1.8V Capable for Low Power
Applications
- PO.1dB > 23dBm Typ @ 2GHz

Applications

- Cellular Handset Applications
- Antenna Tuning Applications
- IEEE802.11b/g WLAN Applications
- Multi-mode GSM, W-CDMA Applications
- WLAN Applications

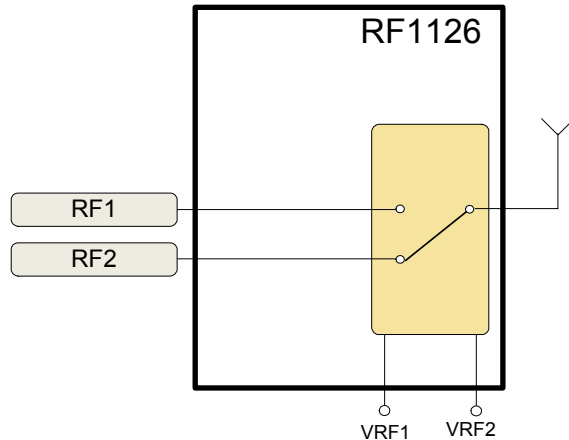

Functional Block Diagram

Product Description

The RF1126 is a single-pole double-throw (SPDT) switch designed for general purpose switching applications which require very low insertion loss and medium power handling capability. The RF1126 is ideally suited for battery operated applications requiring high performance switching with very low DC power consumption. The RF1126 features low insertion loss, high linearity, and very good harmonic characteristics, and is operable from 1.8V to 3.6V control voltage. It is fabricated with 0.5µm GaAs pHEMT process, and is packaged in a very compact 2mmx1.3mm, 6-pin, leadless QFN package.

Ordering Information

RF1126 Broadband Medium Power SPDT Switch
RF1126PCBA-410 Fully Assembled Evaluation Board

Optimum Technology Matching® Applied

- | | | | |
|--------------------------------------|--------------------------------------|--|-----------------------------------|
| <input type="checkbox"/> GaAs HBT | <input type="checkbox"/> SiGe BiCMOS | <input checked="" type="checkbox"/> GaAs pHEMT | <input type="checkbox"/> GaN HEMT |
| <input type="checkbox"/> GaAs MESFET | <input type="checkbox"/> Si BiCMOS | <input type="checkbox"/> Si CMOS | |
| <input type="checkbox"/> InGaP HBT | <input type="checkbox"/> SiGe HBT | <input type="checkbox"/> Si BJT | |

RF MICRO DEVICES®, RFMD®, Optimum Technology Matching®, Enabling Wireless Connectivity™, PowerStar®, POLARIS™ TOTAL RADIO™ and UltimateBlue™ are trademarks of RFMD, LLC. BLUETOOTH is a trademark owned by Bluetooth SIG, Inc., U.S.A. and licensed for use by RFMD. All other trade names, trademarks and registered trademarks are the property of their respective owners. ©2006, RF Micro Devices, Inc.

Absolute Maximum Ratings

| Parameter | Rating | Unit |
|--|-------------|------|
| Voltage | 6.0 | V |
| Maximum Input Power (0.6GHz to 2.5GHz), RF1, RF2 | +28 | dBm |
| Operating Temperature | -30 to +85 | °C |
| Storage Temperature | -65 to +100 | °C |



Caution! ESD sensitive device.

Exceeding any one or a combination of the Absolute Maximum Rating conditions may cause permanent damage to the device. Extended application of Absolute Maximum Rating conditions to the device may reduce device reliability. Specified typical performance or functional operation of the device under Absolute Maximum Rating conditions is not implied.

The information in this publication is believed to be accurate and reliable. However, no responsibility is assumed by RF Micro Devices, Inc. ("RFMD") for its use, nor for any infringement of patents, or other rights of third parties, resulting from its use. No license is granted by implication or otherwise under any patent or patent rights of RFMD. RFMD reserves the right to change component circuitry, recommended application circuitry and specifications at any time without prior notice.



RFMD Green: RoHS compliant per EU Directive 2002/95/EC, halogen free per IEC 61249-2-21, < 1000ppm each of antimony trioxide in polymeric materials and red phosphorus as a flame retardant, and <2% antimony in solder.

| Parameter | Specification | | | Unit | Condition |
|--|---------------|------|------|------|---|
| | Min. | Typ. | Max. | | |
| Overall - $V_{\text{control_high}} = 3\text{V}$ | | | | | VRF1, VRF2 = High = 3 V, VRF1 = VRF2 = Low = 0 V, Temp = 25 °C |
| Operating Frequency | 50 | | 5800 | MHz | |
| Insertion Loss | | | | | |
| RFC - RF1, RFC - RF2 | | 0.21 | 0.24 | dB | RF ON, 50 MHz to 450MHz |
| | | 0.26 | 0.31 | dB | RF ON, 824MHz to 960MHz |
| | | 0.32 | 0.40 | dB | RF ON, 1850MHz to 1990MHz |
| | | 0.36 | 0.45 | dB | RF ON, 2170MHz to 2500MHz |
| | | 0.70 | | dB | RF ON, 5.8GHz |
| Isolation | | | | | |
| RFC - RF1, RFC - RF2 | 31 | 33 | | dB | RF ON, 450MHz |
| | 25 | 27 | | dB | RF ON, 824MHz to 960MHz |
| | 18 | 20 | | dB | RF ON, 1850MHz to 1990MHz |
| | 16 | 19 | | dB | RF ON, 2170MHz to 2500MHz |
| | | 11 | | dB | RF ON, 5.8GHz |
| Return Loss | 19 | 26 | | dB | 500MHz to 3000MHz |
| Second Harmonic | | 75 | | dBc | $P_{\text{IN}} = +15\text{dBm}$, 1980MHz |
| | | 69 | | dBc | $P_{\text{IN}} = +15\text{dBm}$, 2500MHz |
| Third Harmonic | | 90 | | dBc | $P_{\text{IN}} = +15\text{dBm}$, 1980MHz |
| | | 70 | | dBc | $P_{\text{IN}} = +15\text{dBm}$, 2500MHz |
| IIP3 | | | | | |
| RF1 - RFC, RF2 - RFC (Cell) | 61 | 62 | | dBm | Tone 1: 836.5MHz @ 16dBm, Tone 2: 791.5MHz @ -20dBm RX Freq: 881.5MHz |
| RF1 - RFC, RF2 - RFC (IMT) | 59 | 60 | | dBm | Tone 1: 1950MHz @ 16dBm, Tone 2: 1760MHz @ -20dBm RX Freq: 2140MHz |
| Triple Beat Ratio | | | | | |
| Cell/AWS/PCS | | 61 | | dBc | VSWR=2:1 |
| 0.1 dB Compression (PO.1dB) | 21 | 23 | | dBm | 500MHz to 3000MHz |
| Switching Speed | | 160 | 400 | ns | 50% control to 10%/90% |
| Control Current | | 0.4 | 1.0 | μA | $P_{\text{IN}} = 15\text{dBm}$ |

| Parameter | Specification | | | Unit | Condition |
|--|---------------|------|------|---------------|--|
| | Min. | Typ. | Max. | | |
| Overall - $V_{\text{control_high}} = 1.8\text{V}$ | | | | | $V_{\text{RF1}}, V_{\text{RF2}} = \text{High} = 1.8\text{V}, V_{\text{RF1}} = V_{\text{RF2}} = \text{Low} = 0\text{V}, \text{Temp} = 25^\circ\text{C}$ |
| Operating Frequency | 50 | | 5800 | MHz | |
| Insertion Loss | | | | | |
| RFC - RF1, RFC - RF2 | | 0.21 | 0.30 | dB | RF ON, 450MHz |
| | | 0.26 | 0.35 | dB | RF ON, 824MHz to 960MHz |
| | | 0.32 | 0.45 | dB | RF ON, 1850MHz to 1990MHz |
| | | 0.36 | 0.50 | dB | RF ON, 2170MHz to 2500MHz |
| | | 0.70 | | dB | RF ON, 5.8GHz |
| Isolation | | | | | |
| RFC - RF1, RFC - RF2 | 30 | 32 | | dB | RF ON, 450MHz |
| | 24 | 25 | | dB | RF ON, 824MHz to 960MHz |
| | 17 | 19 | | dB | RF ON, 1850MHz to 1990MHz |
| | 15 | 18 | | dB | RF ON, 2170MHz to 2500MHz |
| | | 11 | | dB | RF ON, 5.8GHz |
| Return Loss | 19 | 26 | | dB | 500MHz to 3000MHz |
| 0.1 dB Compression (P0.1dB) | 7 | 11 | | dBm | 500MHz to 3000MHz |
| Switching Speed | | 160 | 400 | ns | 50% control to 10%/90% |
| DC Supply | 1.8 | 3.0 | 3.6 | V | VRF1 and VRF2 (H) |
| | 0 | | 0.4 | V | VRF1 and VRF2 (L) |
| Control Current | | 0.4 | 1.0 | μA | $P_{\text{IN}} = 15\text{dBm}$ |

Control Logic

| | Control Signals | | Signal Paths | |
|----------------|-----------------|------|----------------------|---------|
| | VRF1 | VRF2 | RF1-RFC | RF2-RFC |
| Valid States | 1 | 0 | ON | OFF |
| | 0 | 1 | OFF | ON |
| Invalid States | 0 | 0 | Indeterminate State* | |
| | 1 | 1 | Indeterminate State* | |

0: Logic level low, 0V~0.4V

1: Logic level high, 1.8V~3.6V

Note: In indeterminate states, both signal paths are ON with degraded performance.

| Pin | Function | Description |
|----------|----------|-------------|
| 1 | RF1 | RF Port 1. |
| 2 | GND | Ground. |
| 3 | RF2 | RF Port 2. |
| 4 | VRF2 | Control 2. |
| 5 | RFC | Antenna. |
| 6 | VRF1 | Control 1. |
| Pkg Base | GND | Ground. |

Package Drawing

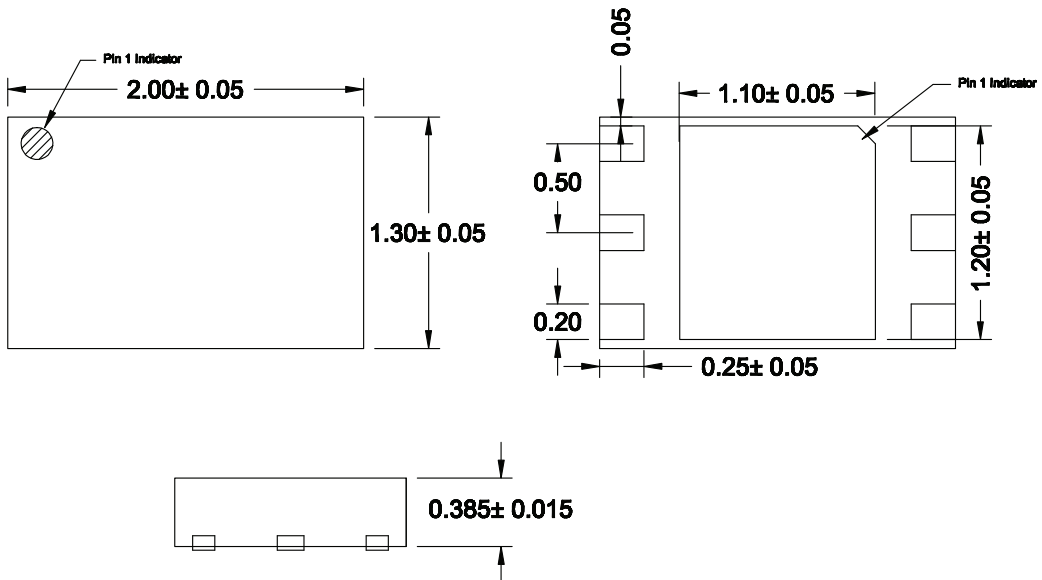

1) PIN 1 INDICATOR SHADED AREA
Notes:

Evaluation Board Schematic

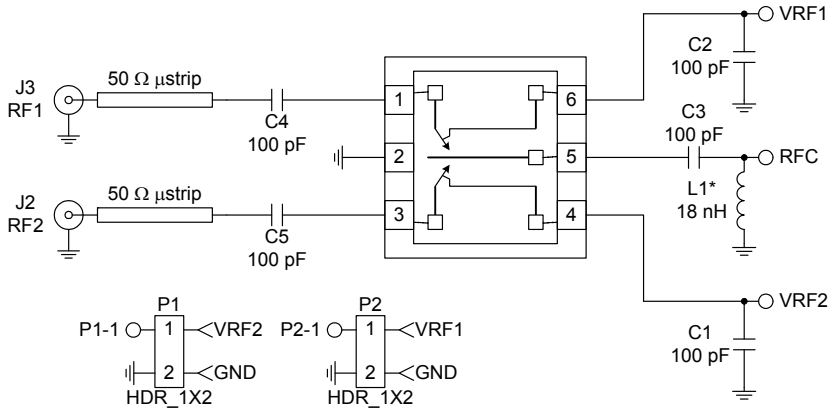

*L1 is optional for IEC61000-4-2 ESD protection.

Evaluation Board Layout

Board Thickness 0.067", Board Material FR-4, Multi-layer

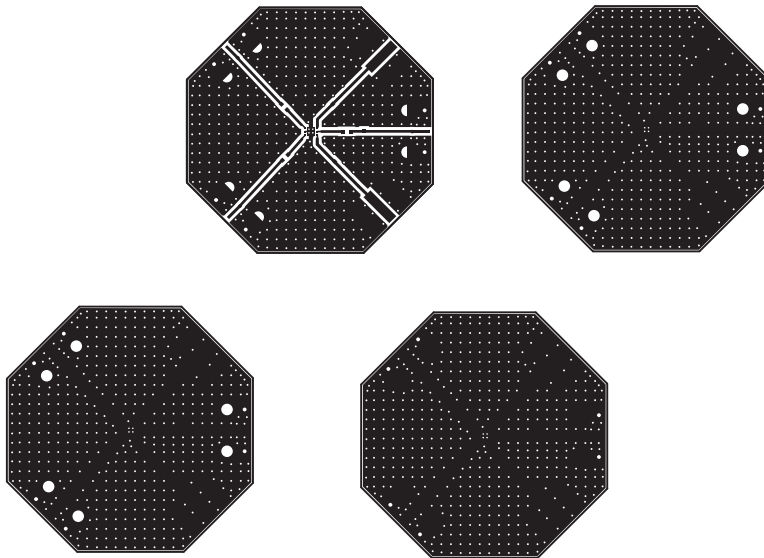

Typical Performance Data on Evaluation Board Note: Fixture losses have been de-embedded (Temp=25 °C, VRF1=VRF2=High=3V VRF1=VRF2=Low=0V)

Insertion Loss
(Temp=25 °C, VRF(H)=3V)

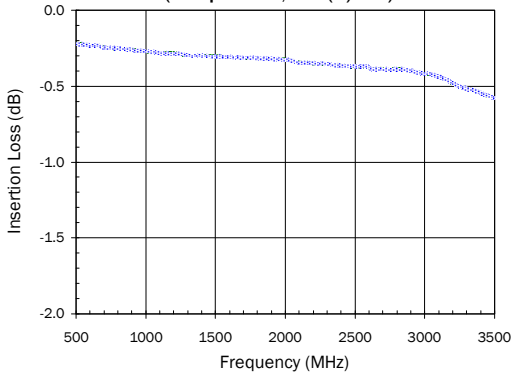

Return Loss
(Temp=25 °C, VRF(H)=3V)

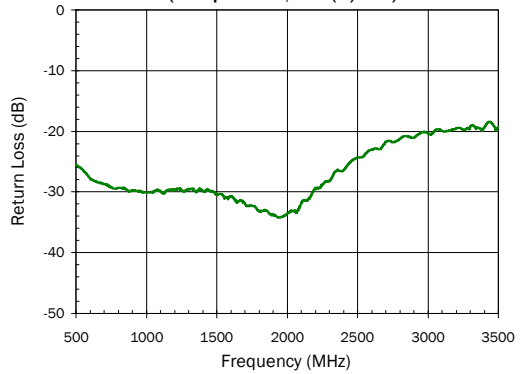

Isolation (Ant - RF port)
(Temp=25 °C, VRF(H)=3V)

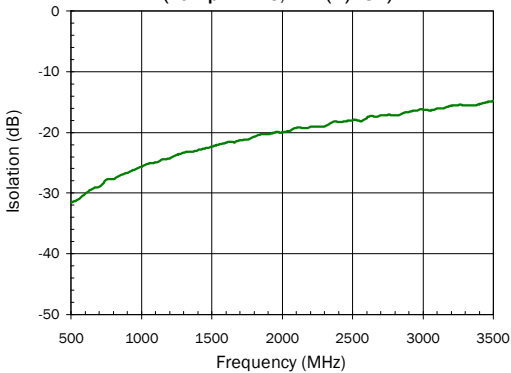

Isolation (Port - Port)
(Temp=25 °C, VRF(H)=3V)

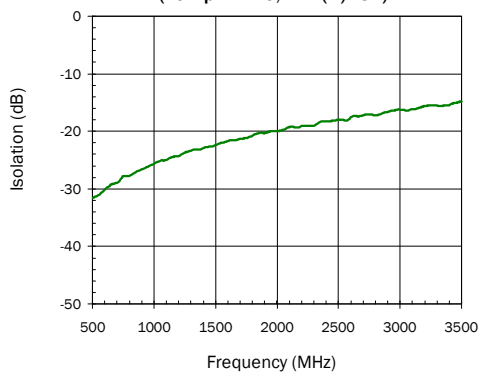

Output Power versus Input Power
(Temperature=25 °C, Frequency=1980MHz, VCTL(H)=3V)

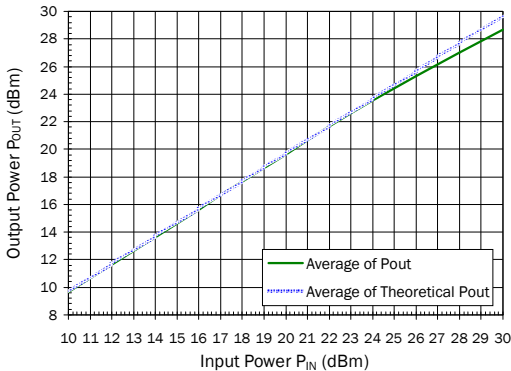

Harmonics
(Temp=25 °C, VRF(H)=3V)

