



Features

- W-CDMA High/Mid/Low Power Modes
- Quad-Band Direct Quadrature Modulator
- Variable Gain PA Drivers
- GMSK Bypass Amplifiers
- LO Frequency Doubler and Divider
- Baseband Filtering

Applications

- EDGE/GSM (GSM850/900) Handsets
- EDGE/GSM (DCS/PCS) Handsets
- W-CDMA Handsets/Data Cards
- W-CDMA/GSM/EDGE Multi-mode Handsets and Data Cards

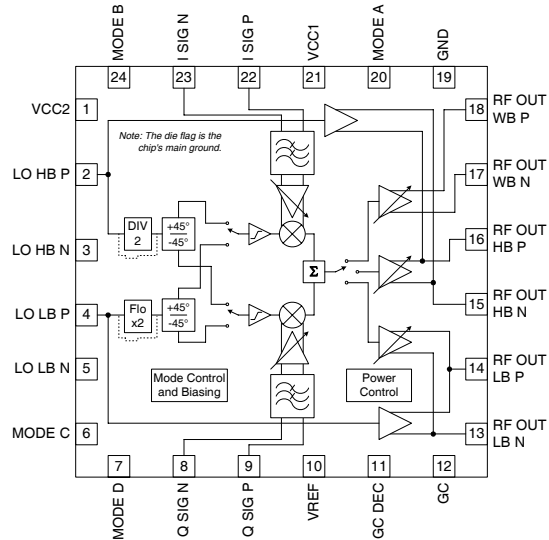

Functional Block Diagram

Product Description

The RF2705 is a low noise, multi-mode, quad-band direct I/Q to RF modulator and PA driver designed for handset applications where multiple modes of operation are required. Frequency doublers, dividers and LO buffers are included to support a variety of LO generation options. Dynamic power control is supported through a single analog input giving 90dB of power control range for the W-CDMA mode and 40dB of power control in the other two modes. Three sets of RF outputs are provided: high band and low band low noise EDGE/GMSK outputs, as well as one wideband W-CDMA output. The device is designed for 2.7V to 3.3V operation, and is assembled in a plastic, 24-pin, 4mmx4mm QFN.

Ordering Information

- | | |
|-----------------|--|
| RF2705G | Low Noise, Multi-Mode, Quad-Band, Quadrature Modulator and PA Driver |
| RF2705GPCBA-41X | Fully Assembled Evaluation Board |

Optimum Technology Matching® Applied

- | | | | |
|--------------------------------------|---|-------------------------------------|-----------------------------------|
| <input type="checkbox"/> GaAs HBT | <input checked="" type="checkbox"/> SiGe BiCMOS | <input type="checkbox"/> GaAs pHEMT | <input type="checkbox"/> GaN HEMT |
| <input type="checkbox"/> GaAs MESFET | <input type="checkbox"/> Si BiCMOS | <input type="checkbox"/> Si CMOS | |
| <input type="checkbox"/> InGaP HBT | <input type="checkbox"/> SiGe HBT | <input type="checkbox"/> Si BJT | |

RF MICRO DEVICES®, RFMD®, Optimum Technology Matching®, Enabling Wireless Connectivity™, PowerStar®, POLARIS™ TOTAL RADIO™ and UltimateBlue™ are trademarks of RFMD, LLC. BLUETOOTH is a trademark owned by Bluetooth SIG, Inc., U.S.A. and licensed for use by RFMD. All other trade names, trademarks and registered trademarks are the property of their respective owners. ©2006, RF Micro Devices, Inc.

Absolute Maximum Ratings

Parameter	Rating	Unit
Supply Voltage	-0.5 to 3.6	V
Storage Temperature	-40 to +150	°C
Operating Ambient Temperature	-40 to +85	°C
Input Voltage, any pin	-0.5 to +3.6	V
Input Power, any pin	+5	dBm



Caution! ESD sensitive device.

Exceeding any one or a combination of the Absolute Maximum Rating conditions may cause permanent damage to the device. Extended application of Absolute Maximum Rating conditions to the device may reduce device reliability. Specified typical performance or functional operation of the device under Absolute Maximum Rating conditions is not implied.

RoHS status based on EUDirective2002/95/EC (at time of this document revision).

The information in this publication is believed to be accurate and reliable. However, no responsibility is assumed by RF Micro Devices, Inc. ("RFMD") for its use, nor for any infringement of patents, or other rights of third parties, resulting from its use. No license is granted by implication or otherwise under any patent or patent rights of RFMD. RFMD reserves the right to change component circuitry, recommended application circuitry and specifications at any time without prior notice.

Parameter	Specification			Unit	Condition
	Min.	Typ.	Max.		
Output Performance with Modulated Baseband Inputs					
Low Band EDGE 8PSK Mode (GSM850/GSM900)					
Mode=Low Band F_{LO}x1 (see Control Logic Truth Table for Mode Control Settings)					
Output Power					V _{CC} =2.7V, T=+25°C
Maximum Output Power with 8PSK Modulated Signal*					
Maximum VGC	0	+2.5		dBm	While meeting spectral mask
Minimum VGC		-39	-37	dBm	While meeting spectral mask
Gain Range		42		dB	Difference between output power at GC=2.0V and GC=0.2V.
Out-of-Band Emission					
Spectrum Emission Mask*					
Frequency Spacing					
200kHz		-36	TBD	dBc	30 kHz BW
250kHz		-43	TBD	dBc	30 kHz BW
400kHz		-67	TBD	dBc	30 kHz BW
600kHz to 1800kHz		-73		dBc	30 kHz BW
1800kHz to 3000kHz		-73		dBc	100kHz BW
3000kHz to 6000kHz		-73		dBc	100kHz BW
≥6000kHz		-75		dBc	100kHz BW
Error Vector Magnitude					
8PSK Modulation					
RMS*		2	3	%	
Origin Offset*		-40	-34	dB	
Peak*		4	9	%	
Output Noise					
At F _C ±20MHz*					
Relative Noise at:					
Maximum Gain		-156		dBc/Hz	GC=2.0V, IQ=1.2V _{p,p} 8PSK
		-152		dBc/Hz	GC=2.0V to 1.4V
Absolute Noise at:					
Maximum Gain		-156		dBm	GC=2.0V, IQ=0V _{p,p}
All Gain Settings		-154		dBm	IQ=1.2V _{p,p} 8PSK

Parameter	Specification			Unit	Condition
	Min.	Typ.	Max.		
General Conditions					
Local Oscillator					
LO LB Input Frequency	824		915	MHz	
RF LB Output Frequency	824		915	MHz	
Input Power	-6.0	0.0	+3.0	dBm	
IQ Baseband Inputs					8PSK
IQ Level		1.2		V _{p,p}	Input IQ signal driven differentially and in quadrature.
IQ Common Mode		1.2		V	
Input Bandwidth	0.7	1.0		MHz	
Baseband Filter Attenuation	20			dB	At 20MHz offset
Output Performance with Modulated Baseband Inputs					
High Band EDGE 8PSK Mode (DCS1800/PCS1900)					
Mode = High Band F_{LO}x1 (see Control Logic Truth Table for Mode Control Settings)					
Output Power					V _{CC} =2.7V, T=+25°C
Maximum Output Power with 8PSK Modulated Signal*					
Maximum VGC	-1	+1.5		dBm	While meeting spectral mask
Minimum VGC		-40	-38	dBm	While meeting spectral mask
Gain Range		42		dB	Difference between output power at GC=2.0V and GC=0.2V.
Out-of-Band Emission					
Spectrum Emission Mask*					
Frequency Spacing					
200kHz		-36	TBD	dBc	30kHz BW
250kHz		-43	TBD	dBc	30kHz BW
400kHz		-67	TBD	dBc	30kHz BW
600kHz to 1800kHz		-73		dBc	30kHz BW
1800kHz to 3000kHz		-73		dBc	100kHz BW
3000kHz to 6000kHz		-73		dBc	100kHz BW
≥6000kHz		-75		dBc	100kHz BW
Error Vector Magnitude					
8PSK Modulation					
RMS*		1.3	3	%	
Origin Offset*		-37	-30	dB	
Peak*		3	11	%	
Output Noise					
At F _C ±20MHz*					
Relative Noise at:					
Maximum Gain		-154		dBc/Hz	GC=2.0V, IQ=1.2V _{p,p} 8PSK
		-150		dBc/Hz	GC=2.0V to 1.4V
Absolute Noise at:					
Maximum Gain		-153		dBm	GC=2.0V, IQ=0V _{p,p}
All Gain Settings		-151		dBm	IQ=1.2V _{p,p} 8PSK

* Not tested in Production

Parameter	Specification			Unit	Condition
	Min.	Typ.	Max.		
General Conditions					
Local Oscillator					
LO HB Input Frequency	1710		1910	MHz	
RF HB Output Frequency	1710		1910	MHz	
Input Power	-6.0	0.0	+3.0	dBm	
IQ Baseband Inputs					
IQ Level		1.2		V _{p,p}	8PSK Input IQ signal driven differentially and in quadrature.
IQ Common Mode		1.2		V	
Input Bandwidth	0.7	1.0		MHz	
Baseband Filter Attenuation	20			dB	At 20MHz offset
Output Performance with Modulated Baseband Inputs					
W-CDMA Mode					
Mode= Wideband F _{LO} x2 (see Control Logic Truth Table for Mode Control Settings)					
Output Power					
Maximum Output Power with W-CDMA Modulated Signal*					
High Power Mode	3	6		dBm	V _{CC} =2.7V, T=+25°C, while meeting 48dBc ALCR GC=2.0V
Medium Power Mode	-4	-1		dBm	GC=1.5V
Gain Range					
High Power Mode		90		dB	Difference between output power at GC=2.0V and GC=0.2V.
Gain Step					
High Power to Medium Power		±0.5		dB	Gain step when switching between power modes in either direction. GC=1.4V
Medium Power to Low Power		TBD		dB	GC=TBD
Out-of-Band Emission					
Adjacent Channel Leakage Power Ratio (ALCR)*					
Channel Spacing					
±5MHz		50		dBc	3.84MHz relative to channel power
±10MHz		65		dBc	3.84MHz relative to channel power
Error Vector Magnitude					
RMS*		1.4		%rms	3GPP W-CDMA
Output Noise					
At F _C ±40MHz*		-152	-146	dBc/Hz	GC=2.0V
			-146	dBc/Hz	GC=2.0V to 1.5V

* Not tested in Production

Parameter	Specification			Unit	Condition
	Min.	Typ.	Max.		
General Conditions					
Local Oscillator					
LO LB Input Frequency	960		990	MHz	
RF WB Output Frequency	1920		1980	MHz	
Input Power	-10.0	0.0	+3.0	dBm	
IQ Baseband Inputs					3GPP W-CDMA HQPSK, 1DPCCH+1DPDCH
IQ Level		0.8		V _{p,p}	Input IQ signal driven differentially and in quadrature.
IQ Common Mode		1.2		V	
Input Bandwidth	8	11		MHz	
Baseband Filter Attenuation	10			dB	At 40MHz offset
Output Performance with CW Baseband Inputs					
Wideband Mode					
Mode=Wideband F _{LO} x2 (see Control Logic Truth Table for Mode Control Settings)					
VGA and PA Driver					V _{CC} =2.7V, T=+25°C, LO=975MHz to 990MHz at -10dBm, IQ=540mV _{p,p} ** at 100kHz, unless otherwise noted
Output Power W-CDMA Modulated*		5		dBm	GC=2.0V, IQ=0.8V _{p,p} at HQPSK
Output Power CW	2	5	8	dBm	GC=2.0V
Gain Control Voltage Range	0.2		2.0	V	
Gain Control Range		92		dB	Difference between output power at GC=2.0V and GC=0.2V
Gain Control Slope		73		dB/V	Calculated between GC=1.0V and 0.5V
Modulator					
Sideband Suppression		-48	-30	dBc	GC=2.0V, No I/Q adjustment
*		-50	-30	dBc	GC=1.5V, No I/Q adjustment
*		-50	-30	dBc	GC=1.0V, No I/Q adjustment
*		-50	-30	dBc	GC=0.5V, No I/Q adjustment
Carrier Suppression		-42	-30	dBc	GC=2.0V, No I/Q adjustment
		-41	-30	dBc	GC=1.5V, No I/Q adjustment
		-38	-30	dBc	GC=1.0V, No I/Q adjustment
		-23	-10	dBc	GC=0.5V, No I/Q adjustment
3rd Harmonic of Modulation Suppression at F _C -3x300kHz		-55	-50	dBc	GC=2.0V
Spurious Outputs					
Spurious Output at Integer Multiples of F _{LO} LB*					GC=2.0V, I/Q=540mV _{p,p} at 100kHz
FLO LB		-60.0		dBm	FLO LB leakage
4xFLO LB		-14.0	0	dBm	Second harmonic of carrier
6xFLO LB		-47.0	0	dBm	Third harmonic of carrier

* Not tested in Production

Parameter	Specification			Unit	Condition
	Min.	Typ.	Max.		
Output Compression					
Output P1dB*		+11.5		dBm	I/Q=100kHz
Intermodulation					
Output IP3*		+20		dBm	GC=2.0V. Extrapolated from IM3 with two baseband tones at 90kHz and 110kHz applied differentially, in quadrature, at both I and Q inputs, each tone 400mV _{p,p}
Intermodulation IM3 tone at F _C +70kHz and F _C +130kHz relative to tones at F _C +90kHz and F _C +110kHz		-37		dBc	GC=2.0V
		-40		dBc	GC=1.5V
Output Performance with CW Baseband Inputs					
Low Band Mode (GSM850/GSM900)					
Mode=Low Band F_{LO}x1 (see Control Logic Truth Table for Mode Control Settings)					
VGA and PA Driver					V _{CC} =2.7V, T=+25°C, LO=824MHz to 915MHz at 0dBm, IQ=800mV _{p,p} ** at 100kHz, unless otherwise noted
Output Power 8PSK Modulated*		+2.5		dBm	GC=2.0V, IQ=1.2V _{p,p} 8PSK
Output Power CW	0	2.2	+5	dBm	GC=2.0V, IQ=800mV _{p,p} at 100kHz
		-1.2		dBm	GC=1.5V, IQ=800mV _{p,p} at 100kHz
*		-13.5		dBm	GC=1.0V, IQ=800mV _{p,p} at 100kHz
		-30		dBm	GC=0.5V, IQ=800mV _{p,p} at 100kHz
	-44	-40	-37	dBm	GC=0.2V, IQ=800mV _{p,p} at 100kHz
Gain Control Voltage Range	0.2		2.0	V	
Gain Control Range		42		dB	Difference between output power at GC=2.0V and GC=0.2V
Gain Control Slope		28		dB/V	Calculated between GC=0.5V and 1.5V
Modulator					
Sideband Suppression		-36	-30	dBc	GC=2.0V, No I/Q adjustment
*		-36	-30	dBc	GC=1.5V, No I/Q adjustment
*		-36	-30	dBc	GC=1.0V, No I/Q adjustment
*		-36	-30	dBc	GC=0.5V, No I/Q adjustment
*		-36	-30	dBc	GC=0.2V, No I/Q adjustment
Carrier Suppression		-44	-34	dBc	GC=2.0V, No I/Q adjustment
		-44	-34	dBc	GC=1.5V, No I/Q adjustment
*		-44	-34	dBc	GC=1.0V, No I/Q adjustment
		-44	-34	dBc	GC=0.5V, No I/Q adjustment
		-40	-34	dBc	GC=0.2V, No I/Q adjustment
3rd Harmonic of Modulation Suppression at F _C -3x300kHz		-49	-40	dBc	GC=2.0V

* Not tested in Production

** Provides the same output power as modulated signal with associated crest factor.

Parameter	Specification			Unit	Condition
	Min.	Typ.	Max.		
Spurious Outputs					$F_{LO}/2$ Mode
Spurious Outputs at Integer Harmonics of $1/2 \times F_{LOHB}^*$					GC=2.0V, I/Q=800mV _{P,P} at 100kHz
FLO HB		-62.0		dBm	Second harmonic of carrier and LO leakage
$(3/2) \times F_{LO LB}$		-19.0		dBm	Third harmonic of carrier
Output Compression					
Output P1dB*		+7.0		dBm	I/Q=100kHz
Output Performance with CW Baseband Inputs					
Low Band Mode (GSM850/GSM900), cont'd					
Mode=Low Band $F_{LO} \times 1$ (see Control Logic Truth Table for Mode Control Settings)					
Intermodulation					
Output IP3*		+20.0		dBm	GC=2.0V. Extrapolated from IM3 with two baseband tones at 90kHz and 110kHz applied differentially, in quadrature, at both I and Q inputs, each tone 400mV _{P,P} .
Intermodulation IM3 tone at F_C+70 kHz and F_C+130 kHz relative to tones at F_C+90 kHz and F_C+110 kHz		-48		dBc	GC=2.0V
Low Band Bypass Mode (GSM850/GSM900)					
Mode=Low Band Bypass (see Control Logic Truth Table for Mode Control Settings)					
PA Driver					$V_{CC}=2.7V$
GMSK Input Power*	-3	0	+3	dBm	At LO LB input from a 50Ω source.
GMSK Output Power	5.0	7.5	10.0	dBm	At RF LB output
Output Impedance*		50		Ω	
Output Noise					
At $F_C \pm 20$ MHz*		-161	-159	dBc/Hz	AM+PM noise, LO=0dBm

* Not tested in Production

** Provides the same output power as modulated signal with associated crest factor.

Parameter	Specification			Unit	Condition
	Min.	Typ.	Max.		
Output Performance with CW Baseband Inputs					
High Band Mode (DCS1800/PCS1900)					
Mode= High Band F_{LO}x1 (see Control Logic Truth Table for Mode Control Settings)					
VGA and PA Driver					V _{CC} =2.7V, T=+25°C, LO=1710MHz to 1910MHz at 0dBm, IQ=800mV _{p,p} ** at 100kHz, unless otherwise noted
Output Power 8PSK Modulated*	0	2.2		dBm	GC=2.0V, IQ=1.2V _{p,p} 8PSK
Output Power CW	0	2	+6.0	dBm	GC=2.0V, IQ=800mV _{p,p} at 100kHz
		-1.6		dBm	GC=1.5V, IQ=800mV _{p,p} at 100kHz
*		-17.6		dBm	GC=1.0V, IQ=800mV _{p,p} at 100kHz
		-30		dBm	GC=0.5V, IQ=800mV _{p,p} at 100kHz
	-44	-40	-37	dBm	GC=0.2V, IQ=800mV _{p,p} at 100kHz
Gain Control Voltage Range	0.2		2.0	V	
Gain Control Range		42		dB	Difference between output power at GC=2.0V and GC=0.2V
Gain Control Slope		28		dB/V	Calculated between GC=0.5V and 1.5V
Modulator					
Sideband Suppression		-45	-30	dBc	GC=2.0V, No I/Q adjustment
*		-45	-30	dBc	GC=1.5V, No I/Q adjustment
*		-45	-30	dBc	GC=1.0V, No I/Q adjustment
*		-45	-30	dBc	GC=0.5V, No I/Q adjustment
*		-45	-30	dBc	GC=0.2V, No I/Q adjustment
Carrier Suppression		-40	-34	dBc	GC=2.0V, No I/Q adjustment
		-40	-34	dBc	GC=1.5V, No I/Q adjustment
*		-40	-33	dBc	GC=1.0V, No I/Q adjustment
		-39	-30	dBc	GC=0.5V, No I/Q adjustment
		-37	-30	dBc	GC=0.2V, No I/Q adjustment
3rd Harmonic of Modulation Suppression at F _C -3x300kHz		-50	-40	dBc	GC=2.0V
Spurious Outputs					
F_{LO}x2 Mode					
Spurious Outputs at Integer Harmonics of 1/2xFLOHB					GC=2.0V, I/Q=800mV _{p,p} at 100kHz
FLO LB		-70.0		dBm	FLO LB leakage
4xFLO LB		-25.0		dBm	Second harmonic of carrier
6xFLO LB		-40.0		dBm	Third harmonic of carrier
Output Compression					
Output P1dB*		+8.0		dBm	I/Q=100kHz

* Not tested in Production

** Provides the same output power as modulated signal with associated crest factor.

Parameter	Specification			Unit	Condition
	Min.	Typ.	Max.		
Output Performance with CW Baseband Inputs					
High Band Mode (DCS1800/PCS1900), cont'd					
Mode=High Band F_{LO}x1 (see Control Logic Truth Table for Mode Control Settings)					
Intermodulation					
Output IP3*		+20		dBm	GC=2.0V. Extrapolated from IM3 with two baseband tones at 90kHz and 110kHz applied differentially, in quadrature, at both I and Q inputs, each tone 400mV _{p,p}
Intermodulation IM3 tone at F _C +70kHz and F _C +130kHz relative to tones at F _C +90kHz and F _C +110kHz		-53	-42	dBc	GC=2.0V
Output Performance with CW Baseband Inputs					
Wideband Mode					
Mode=Wideband F_{LO}x2 (see Control Logic Truth Table for Mode Control Settings)					
VGA and PA Driver					
Output Power W-CDMA Modulated*		5		dBm	V _{CC} =2.7V, T=+25°C, LO=975MHz to 990MHz at -10dBm, IQ=540mV _{p,p} ** at 100kHz, unless otherwise noted
Output Power CW	2	5	8	dBm	GC=2.0V
Gain Control Voltage Range	0.2		2.0	V	
Gain Control Range		92		dB	Difference between output power at GC=2.0V and GC=0.2V
Gain Control Slope		73		dB/V	Calculated between GC=1.0V and 0.5V
Modulator					
Sideband Suppression		-48	-30	dBc	GC=2.0V, No I/Q adjustment
*		-50	-30	dBc	GC=1.5V, No I/Q adjustment
*		-50	-30	dBc	GC=1.0V, No I/Q adjustment
*		-50	-30	dBc	GC=0.5V, No I/Q adjustment
Carrier Suppression		-42	-30	dBc	GC=2.0V, No I/Q adjustment
		-41	-30	dBc	GC=1.5V, No I/Q adjustment
		-38	-30	dBc	GC=1.0V, No I/Q adjustment
		-23	-10	dBc	GC=0.5V, No I/Q adjustment
3rd Harmonic of Modulation Suppression at F _C -3x300kHz		-55	-50	dBc	GC=2.0V
Spurious Outputs					
Spurious Output at Integer Multiples of FLO LB*					GC=2.0V, I/Q=540mV _{p,p} at 100kHz
FLO LB		-60.0		dBm	FLO LB leakage
4xFLO LB		-14.0	0	dBm	Second harmonic of carrier
6xFLO LB		-47.0	0	dBm	Third harmonic of carrier
Output Compression					
Output P1dB*		+11.5		dBm	I/Q=100kHz

Parameter	Specification			Unit	Condition
	Min.	Typ.	Max.		
Intermodulation					
Output IP3*		+20		dBm	GC=2.0V. Extrapolated from IM3 with two baseband tones at 90kHz and 110kHz applied differentially, in quadrature, at both I and Q inputs, each tone 400mV _{p,p}
Intermodulation IM3 tone at F _C +70kHz and F _C +130kHz relative to tones at F _C +90kHz and F _C +110kHz		-37		dBc	GC=2.0V
		-40		dBc	GC=1.5V
High Band Bypass Mode (DCS1800/PCS1900)					
Mode=High Band Bypass (see Control Logic Truth Table for Mode Control Settings)					
PA Driver					
					V _{CC} =2.7V
GMSK Input Power*	-3	0	+3	dBm	At LO LB input from a 50Ω source.
GMSK Output Power	4.0	6.8	9.0	dBm	At RF LB output
Output Impedance*		50		Ω	
Output Noise					
At F _C ±20MHz*		-161	-159	dBc/Hz	AM+PM noise, LO=0dBm

* Not tested in Production

** Provides the same output power as modulated signal with associated crest factor.

Parameter	Specification			Unit	Condition
	Min.	Typ.	Max.		
General Specifications					
Operating Range					
Supply Voltage	2.7		3.3	V	
Temperature	-40		+85	°C	
Current Consumption					
					Refer to Logic Control Truth Table for Mode Control Pin Voltages.
Sleep		<1	10	μA	
Wideband F _{LO} X1 (high power)		114		mA	GC=2.0V
* (medium power)		85		mA	GC=0.2V
* (medium power)		89		mA	GC=2.0V
* (low power)		54		mA	GC=0.2V
* (low power)		63		mA	GC=2.0V. See Note 1.
* (low power)		42		mA	GC=0.2V. See Note 1.
Wideband F _{LO} X2 (high power)		110		mA	GC=2.0V
(medium power)		84		mA	GC=0.2V
(medium power)		80		mA	GC=2.0V
(low power)		53		mA	GC=0.2V
(low power)		54		mA	GC=2.0V. See Note 1.
(low power)		41		mA	GC=0.2V. See Note 1.
High Band F _{LO} X2		72		mA	GC=2.0V
Low Band F _{LO} /2		82		mA	GC=2.0V
High Band Bypass		23		mA	
Low Band Bypass		22		mA	
High Band F _{LO} X1		76		mA	GC=2.0V
Low Band F _{LO} X1		74		mA	GC=2.0V
Logic Levels					
Input Logic 0	0		0.4	V	
Input Logic 1	1.4		V _{CC}	V	
Logic Pins Input Current		<1.0		μA	CMOS inputs
LO Input Ports					
LO LB Input Frequency Range	800		1000	MHz	
LO HB Input Frequency Range	1600		2000	MHz	
Input Impedance		50		Ω	Externally matched

Parameter	Specification			Unit	Condition
	Min.	Typ.	Max.		
I/Q Baseband Inputs					
Baseband Input Voltage	1.15		1.25	V	Common mode voltage
Baseband Input Level					
EDGE		1.2		V _{p,p}	Differential
W-CDMA		0.8		V _{p,p}	1DPCCH + 1DPDCH. See Note 1.
GMSK			1.0	V _{p,p}	Differential
Baseband Input Impedance		100k 1pF		Ω	Measured at 100kHz
Input Bandwidth					
EDGE	0.7	1.0		MHz	
W-CDMA	8.0	11.0		MHz	
Baseband Filter Attenuation					
EDGE	20			dB	At 20MHz
W-CDMA	10			dB	At 40MHz
Baseband Input DC Current	-10	0	10	μA	
Gain Control					
Gain Control Voltage	0.2		2.2	V	
Gain Control Impedance		10		kΩ	

Note 1: In low power mode it is recommended that the IQ level be reduced to 0.4V_{p,p}. If IQ level is >0.4V_{p,p} this mode should be used for W-CDMA TX power levels below -20dBm (measured at antenna).

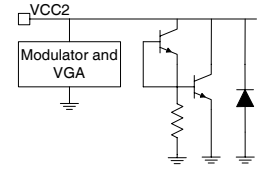
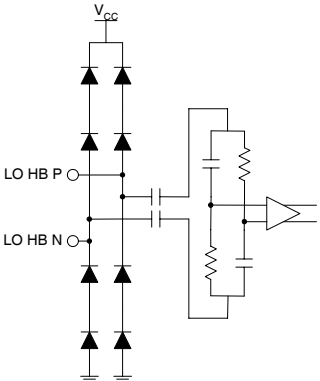
Pin	Function	Description	Interface Schematic
1	VCC2	Supply for LO buffers, frequency doubler and dividers.	
2	LO HB P	<p>High band local oscillator input (1800MHz). In "low band $F_{LO}/2$" modes the signal (LOHBP-LOHBN) undergoes a frequency division of 2 to provide the low band LO signal for the modulator. In "high band $F_{LO} \times 1$" modes the signal (LOHBP-LOHBN) is used as the high band LO signal for the modulator. In "high band bypass" a modulated DCS1800/PCS1900 signal (LOHBP-LOHBN) is switched into the RF signal path. The modulator is disabled and the signal is routed to the RFOutHb outputs through a differential PA driver amplifier.</p> <p>The LOHBP input is AC-coupled internally.</p> <p>The noise performance, carrier suppression at low output powers and sideband suppression all vary with LO power. The optimum LO power is between -3dBm and +3dBm. The device will work with LO powers as low as -20dBm however this is at the expense of higher phase noise in the LO circuitry and poorer sideband suppression.</p> <p>The input impedance should be externally matched to 50Ω. The port can be driven either differentially or single ended. The port impedance does not vary significantly between active and power down modes.</p> <p>The RF2705 is intended for use with the RF6002. This performs the GSM GMSK modulation within a Frac-N synthesizer loop. The 8PSK EDGE and W-CDMA signal modulations are performed in the RF2705 and uses the RF6002's synthesizers to generate the LO signals. The LO signal for EDGE900 mode is derived by frequency division by 2 of the RF6002's DCS1800 VCO. This helps protect the system against PA pulling.</p>	
3	LO HB N	<p>The complementary LO input for both LOHBP LO signals. In any of the modes the LOHB input may be driven either single ended or differentially. If the LO is driven single ended then the PCB board designer can ground this pin.</p> <p>It is recommended that if this pin is grounded that it is kept isolated from the GND1 pin and the die flag ground. All connections to any other ground should be made through a ground plane. Poor routing of this ground signal can significantly degrade the LO leakage performance.</p>	See pin 2.

Pin	Function	Description	Interface Schematic
4	LO LB P	<p>Low band local oscillator input (900MHz). In "wideband $F_{LO} \times 2$" and "high band $F_{LO} \times 2$" modes the signal (LOLBP-LOLBN) is doubled in frequency to provide the LO signal for the modulator. In "Low band $F_{LO} \times 1$" modes the signal (LOLBP-LOLBN) is used as the LO signal for the modulator.</p> <p>In "Low band Bypass" a modulated GSM900 signal (LOLBP-LOLBN) is switched into the RF signal path. The modulator is disabled and the signal is routed to the RFOutLb outputs through a differential PA driver amplifier. This LOLBP input is AC-coupled internally.</p> <p>The noise performance, carrier suppression at low output powers and side-band suppression performance are functions of LO power. The optimum LO power is between -3dBm and +3dBm. The device will work with LO powers as low as -20dBm however this is at the expense of higher noise performance at high output powers and poorer sideband suppression.</p> <p>The input impedance should be externally matched to 50Ω. The port impedance does not vary significantly between active and powered modes. The RF2705 is intended for use with the RF6002 which performs the GSM GMSK modulation within a Frac-N synthesizer loop. The 8PSK EDGE and W-CDMA signal modulations are performed in the RF2705 and uses the RF6002's synthesizers to generate the LO signals. The LO signal for DCS1800 mode is derived by frequency doubling RF6002's GSM900 VCO. This helps protect the system against PA pulling.</p>	
5	LO LB N	<p>The complementary LO input for both LOLBP LO signals. In any of the modes the LOLB input may be driven either single ended or differentially. If the LO is driven single ended then the PCB board designer can ground this pin.</p> <p>It is recommended that if this pin is grounded that it is kept isolated from the GND1 pin and the die flag ground. All connections to any other ground should be made through a ground plane. Poor routing of this GndLO signal can significantly degrade the LO leakage performance.</p>	See pin 4.
6	MODE C	<p>Chip enable control pin. See the Logic Truth table. CMOS Logic inputs: Logic 0=0V to 0.4V; Logic 1=1.4V to V_{CC}.</p>	
7	MODE D	<p>Mode control pin. See the Logic Truth table. CMOS Logic inputs: Logic 0=0V to 0.4V; Logic 1=1.4V to V_{CC}.</p>	See pin 6.

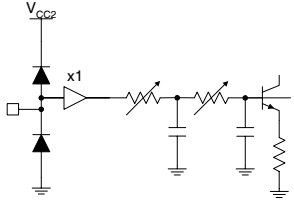
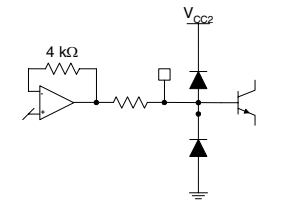
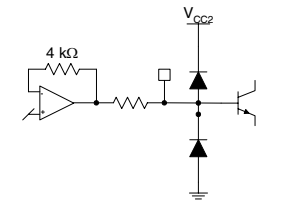
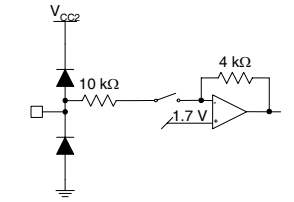
Pin	Function	Description	Interface Schematic
8	Q SIG N	<p>Quadrature Q channel negative baseband input port. Best performance is achieved when the QSIGP and QSIGN are driven differentially with a 1.2V common mode DC voltage. The recommended differential drive level ($V_{QSIGP} - V_{QSIGN}$) is 1.2V_{P-P} for EDGE, 0.8V_{P-P} for W-CDMA modulation and 1.0V_{P-P} for GMSK modulation.</p> <p>This input should be DC-biased at 1.2V. In sleep mode an internal FET switch is opened, the input goes high impedance and the modulator is de-biased.</p> <p>Phase or amplitude errors between the QSIGP and QSIGN signals will result in a common-mode signal which may result in an increase in the even order distortion of the modulation in the output spectrum.</p> <p>DC offsets between the QSIGP and QSIGN signals will result in increased carrier leakage. Small DC offsets may be deliberately applied between the ISIGP/ISIGN and QSIGP/QSIGN inputs to cancel out the LO leakage. The optimum corrective DC offsets will change with mode, frequency and gain control.</p> <p>Common-mode noise on the QSIGP and QSIGN should be kept low as it may degrade the noise performance of the modulator.</p> <p>Phase offsets from quadrature between the I and Q baseband signals results in degraded sideband suppression.</p>	
9	Q SIG P	Quadrature Q channel negative baseband input port. See pin 8.	See pin 8.
10	VREF	<p>Voltage reference decouple. External 10nF decoupling capacitor to ground. The voltage on this pin is typically 1.67V when the chip is enabled. The voltage is 0V when the chip is powered down. The purpose of this decoupling capacitor is to filter out low frequency noise (20MHz) on the gain control lines.</p> <p>Poor positioning of the VREF decoupling capacitor can cause a degradation in LO leakage.</p> <p>A voltage of around 2.5V on this pin indicates that the die flag under the chip is not grounded and the chip is not biased correctly.</p>	
11	GC DEC	<p>Gain control voltage decouple with an external 1nF decoupling capacitor to ground. The voltage on this pin is a function of gain control (GC) voltage when the chip is enabled. The voltage is 0V when the chip is powered down. The purpose of this decoupling capacitor is to filter out low frequency noise (20MHz) on the gain control lines. The size capacitor on the GC DEC line will effect the settling time response to a step in gain control voltage. A 1nF capacitor equates to around 200ns settling time and a 0.5nF capacitor equates to a 100ns settling time. There is a trade-off between settling time and noise contributions by the gain control circuitry as gain control is applied.</p> <p>Poor positioning of the VREF decoupling capacitor can cause a degradation in LO leakage.</p>	
12	GC	Gain control voltage. Maximum output power at 2.0V. Minimum output power at 0V. When the chip is enabled the input impedance is 10kΩ to 1.67V _{DC} . When the chip is powered down a FET switch is opened and the input goes high impedance.	

Pin	Function	Description	Interface Schematic
13	RF OUT LB N	Differential low band PA driver amplifier output. This output is intended for low band (GSM850/900) operation and drives a differential SAW. A bypass mode allows the low band PA driver amplifier's input to be switched between the signal from the modulator and the signal applied at LOLB. This enables a GMSK-modulated signal on the LOLB input to be switched into the RF signal path. The output is an open collector. The outputs are matched off-chip.	
14	RF OUT LB P	Complementary differential low band PA driver amplifier output. See pin 13.	See pin 13.
15	RF OUT HB N	Differential high band PA Driver amplifier output. This output is intended for DCS1800/PCS1900 band operation. A bypass mode allows the high band PA driver amplifier's input to be switched between the signal from the modulator and the signal applied at LOHB. This enables a GMSK-modulated DCS1800/PCS1900 signal on the LOHB input to be switched into the RF signal path. The output is an open collector. The outputs are matched off-chip.	
16	RF OUT HB P	Complementary differential high band PA driver amplifier output. See pin 15.	See pin 15.
17	RF OUT WB N	Differential high band PA driver amplifier output. This output is intended for wide band (W-CDMA) applications. The output is an open collector. The output are matched off-chip.	
18	RF OUT WB P	Complementary differential wideband PA driver amplifier output. See pin 17.	See pin 17.
19	GND	Ground.	
20	MODE A	Mode control pin. See the Logic Truth table. CMOS Logic inputs: Logic 0=0V to 0.4V; Logic 1=1.4V to V _{CC} .	See pin 6.
21	VCC1	Supply for modulator, VGA and PA driver amplifiers.	

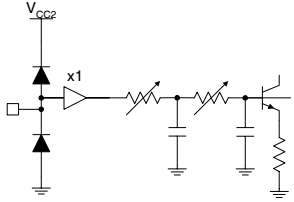
Pin	Function	Description	Interface Schematic
22	I SIG P	<p>In-phase I channel positive baseband input port. Best performance is achieved when the ISIGP and ISIGN are driven differentially with a 1.2V common mode DC voltage. The recommended differential drive level ($V_{ISIGP}-V_{ISIGN}$) is $1.2V_{P,P}$ for EDGE, $0.8V_{P,P}$ W-CDMA modulation and $1.0V_{P,P}$ for GMSK modulation.</p> <p>This input should be DC-biased at 1.2V. In sleep mode an internal FET switch is opened, the input goes high impedance and the modulator is de-biased.</p> <p>Phase or amplitude errors between the ISIGP and ISIGN signals will result in a common-mode signal which may result in an increase in the even order distortion of the modulation in the output spectrum.</p> <p>DC offsets between the ISIGP and ISIGN signals will result in increased carrier leakage. Small DC offsets may be deliberately applied between the ISIGP/ISIGN and QSIGP/QSIGN inputs to cancel out the LO leakage. The optimum corrective DC offsets will change with mode, frequency and gain control.</p> <p>Common-mode noise on the ISIGP and ISIGN should be kept low as it may degrade the noise performance of the modulator.</p> <p>Phase offsets from quadrature between the I and Q baseband signals results in degrades sideband suppression.</p>	
23	I SIG N	In-phase I channel negative baseband input port. See pin 22.	See pin 22.
24	MODE B	Mode control pin. See the Logic Truth table. CMOS Logic inputs: Logic 0=0V to 0.4V; Logic 1= 1.4V to V_{CC} .	See pin 6.
Pkg Base	DIE FLAG	Ground for LO section, modular, biasing, variable gain amplifier, and substrate.	

LO Frequency Planning Options for European 3GPP W-CDMA/EDGE

Recommended Frequency Plan: Frequency Doubler/Divide by 2/GMSK Modulator Bypass Modes

Output Frequency Band			Modulation Format	LO Port	LO Frequency Range		Comments
Band	Lower Limit	Upper Limit			Lower Limit	Upper Limit	
GSM850	824MHz	849MHz	EDGE 8PSK	LOHB	1648MHz	1698MHz	F _{LO} /2 Divide by 2
GSM850	824MHz	849MHz	GSM GMSK	LOLB	824MHz	849MHz	F _{LO} _bypass Bypass, GMSK-modulated LO
GSM900	880MHz	915MHz	EDGE 8PSK	LOHB	1760MHz	1830MHz	F _{LO} /2 Divide by 2
GSM900	880MHz	915MHz	GSM GMSK	LOLB	880MHz	915MHz	F _{LO} _bypass Bypass, GMSK-modulated LO
DCS1800	1710MHz	1785MHz	EDGE 8PSK	LOLB	855MHz	892.5MHz	F _{LO} x2 Frequency Doubler
DCS1800	1710MHz	1785MHz	GSM GMSK	LOHB	1710MHz	1785MHz	F _{LO} _bypass Bypass, GMSK-modulated LO
PCS1900	1850MHz	1910MHz	EDGE 8PSK	LOLB	925MHz	955MHz	F _{LO} x2 Frequency Doubler
PCS1900	1850MHz	1910MHz	GSM GMSK	LOHB	1850MHz	1910MHz	F _{LO} _bypass Bypass, GMSK-modulated LO
W-CDMA1950	1920MHz	1980MHz	3GPP W-CDMA	LOLB	960MHz	990MHz	F _{LO} x2 Frequency Doubler

On Frequency LO with GMSK Modulator Bypass Modes

Output Frequency Band			Modulation Format	LO Port	LO Frequency Range		Comments
Band	Lower Limit	Upper Limit			Lower Limit	Upper Limit	
GSM850	824MHz	849MHz	EDGE 8PSK	LOLB	824MHz	849MHz	F _{LO} x1 On Frequency
GSM850	824MHz	849MHz	GSM GMSK	LOLB	824MHz	849MHz	F _{LO} _bypass Bypass, GMSK-modulated LO
GSM900	880MHz	915MHz	EDGE 8PSK	LOLB	880MHz	915MHz	F _{LO} x1 On Frequency
GSM900	880MHz	915MHz	GSM GMSK	LOLB	880MHz	915MHz	F _{LO} _bypass Bypass, GMSK-modulated LO
DCS1800	1710MHz	1785MHz	EDGE 8PSK	LOHB	1710MHz	1785MHz	F _{LO} x1 On Frequency
DCS1800	1710MHz	1785MHz	GSM GMSK	LOHB	1710MHz	1785MHz	F _{LO} _bypass Bypass, GMSK-modulated LO
PCS1900	1850MHz	1910MHz	EDGE 8PSK	LOHB	1850MHz	1910MHz	F _{LO} x1 On Frequency
PCS1900	1850MHz	1910MHz	GSM GMSK	LOHB	1850MHz	1910MHz	F _{LO} _bypass Bypass, GMSK-modulated LO
W-CDMA1950	1920MHz	1980MHz	3GPP W-CDMA	LOHB	1920MHz	1980MHz	F _{LO} x1 On Frequency

Control Logic Truth Table

Mode Description	Input Logic				Active RF I/Os	Comment
	Mode A	Mode B	Mode C	Mode D		
Sleep Mode						
Sleep	X	0	0	0		Sleep
Frequency Doubler/Divide by 2 Options						
Wideband F_{LO}x2 (High Power) Modulator and frequency doubler enabled	1	0	1	0	LoLbP LoLbN RFOutWb P RFOutWb N	Bands: 1920MHz to 1980MHz Modulation: 3GPP W-CDMA
Wideband F_{LO}x2 (Medium Power) Modulator and frequency doubler enabled	1	0	1	1	LoLbP LoLbN RFOutWb P RFOutWb N	Bands: 1920MHz to 1980MHz Modulation: 3GPP W-CDMA
Wideband F_{LO}x2 (Low Power) Modulator and frequency doubler enabled	1	0	0	1	LoLbP LoLbN RFOutWb P RFOutWb N	Bands: 1920MHz to 1980MHz Modulation: 3GPP W-CDMA
High Band F_{LO}x2 Modulator and frequency doubler enabled	1	1	1	1	LoLbP LoLbN RFOutHb P RFOutHb N	Bands: DCS1800 or PCS1900 Modulation: GMSK, TDMA and 8PSK EDGE
Low Band F_{LO}/2 Modulator and divide by 2 enabled	1	1	0	1	LoHbP LoHbN RFOutLb P RFOutLb N	Bands: GSM900 or GSM850 Modulation: GMSK, TDMA and 8PSK EDGE
GMSK Modulator Bypass Options						
Low Band Bypass Modulator bypass enabled	X	1	0	0	LoLbP LoLbN RFOutLb P RFOutLb N	Bands: GSM850 or GSM900 Modulation: GMSK
High Band Bypass Modulator bypass enabled	X	1	1	0	LoHbP LoHbN RFOutHb P RFOutHb N	Bands: DCS1800 or PCS1900 Modulation: GMSK
On-Frequency LO Options						
Wideband F_{LO}x1 (High Power) Modulator and on-frequency LO enabled	0	0	1	0	LoHbP LoHbN RFOutWb P RFOutWb N	Bands: 1920MHz to 1980MHz Modulation: 3GPP W-CDMA
Wideband F_{LO}x1 (Medium Power) Modulator and on-frequency LO enabled	0	0	1	1	LoHbP LoHbN RFOutWb P RFOutWb N	Bands: 1920MHz to 1980MHz Modulation: 3GPP W-CDMA
Wideband F_{LO}x1 (Low Power) Modulator and on-frequency LO enabled	0	0	0	1	LoHbP LoHbN RFOutWb P RFOutWb N	Bands: 1920MHz to 1980MHz Modulation: 3GPP W-CDMA
High Band F_{LO}x1 Modulator and on-frequency LO enabled	0	1	1	1	LoHbP LoHbN RFOutHb P RFOutHb N	Bands: DCS1800 or PCS1900 Modulation: GMSK, TDMA and 8PSK EDGE
Low Band F_{LO}x1 Modulator and on-frequency LO enabled	0	1	0	1	LoLbP LoLbN RFOutLb P RFOutLb N	Bands: GSM900 to GSM850 Modulation: GMSK, TDMA and 8PSK EDGE

Package Drawing

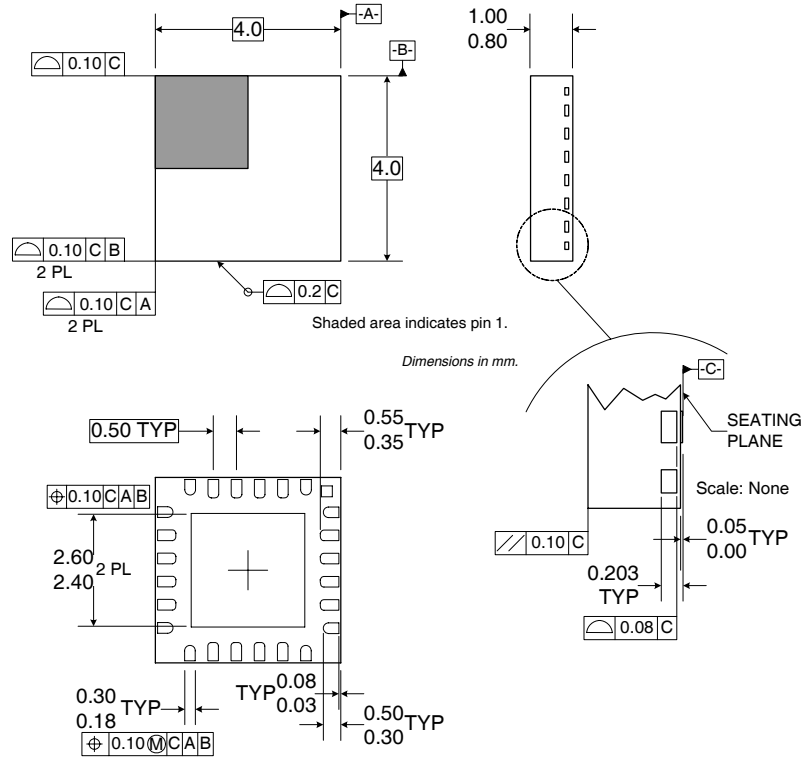

Application Information

The baseband inputs of the RF2705 must be driven with balanced signals. Amplitude and phase matching <0.5dB and <0.5 degrees are recommended. Phase or gain imbalances between the complementary input signals will cause additional distortion including some second order baseband distortion.

The RF2705 is designed to be driven with either single-ended or differential LO signals. Driving the chip differentially is beneficial in improving the LO leakage performance. Decreasing the LO drive level will also improve LO leakage, but the output noise performance will be degraded. Driving the LO level too high will degrade linearity.

The ground lines for the LO sections are brought out of the chip independently from the ground to the RF and modulator sections. This is intended to give the board design the independence of isolating the LO signals from the RF output sections.

The RF2705 includes frequency doubler and divider modes that allow the LO to operate at half or twice the frequency depending on the application. This provides some flexibility in improving VCO isolation and LO leakage through frequency translation.

The RF outputs use open collector architecture and may be biased at voltages higher than V_{CC} . In practice, biasing at a higher voltage may improve the intermodulation performance. The load resistors are selected to provide sufficient output power while maintaining good linearity.

The GC DEC and V_{REF} output pins should be decoupled to ground. A 10nF capacitor on V_{REF} and a 1nF capacitor on GC CEC are recommended. The purpose of these capacitors is to filter out low frequency noise (20MHz) in the gain control lines that may cause noise on the RF signal. The capacitor on the GC DEC line will effect the settling time of the step response in power control voltage. A 1nF capacitor equates to around a 200ns settling time; a 0.5nF capacitor equates to a 100ns settling time. There is a trade-off between setting time and phase noise as gain control is applied.

As with any RF circuit, the RF2705 is sensitive to PC board layout. The suggested schematic and board layout is included as a guideline. Proper grounding of the die flag under the chip is essential in achieving acceptable RF performance. A symmetric output structure will maintain signal balance while keeping the RF lines short will reduce losses. Proper routing and bypassing of the supply lines will improve stability and performance, especially under low gain control settings where carrier suppression becomes crucial. The location and value of the bypass capacitor on pin 1 is critical in promoting good carrier suppression and is designated to resonate out the series wire bond and PC board inductance.

Application Schematic

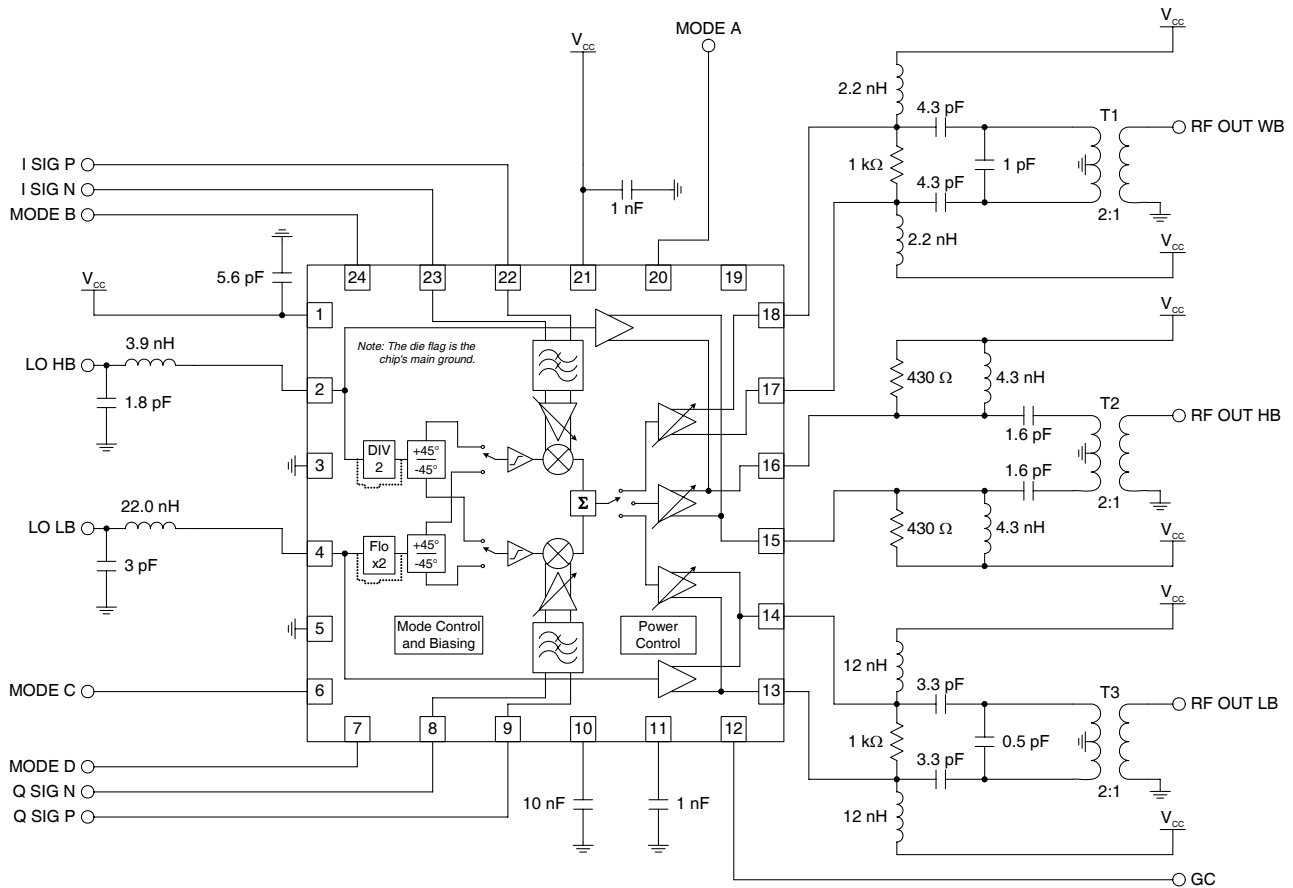

Evaluation Board Schematic

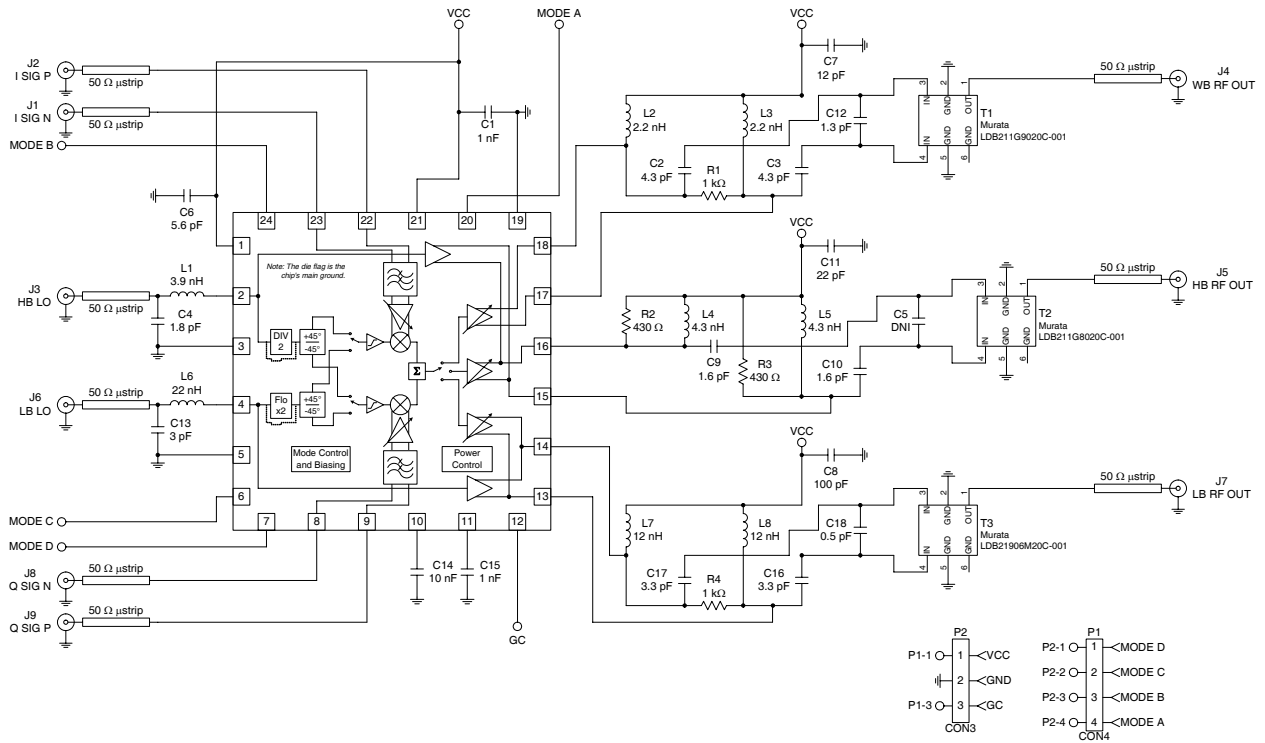

Evaluation Board Layout Board Size 2.250" x 2.250"

Board Thickness 0.032", Board Material FR-4, Multi-Layer Assembly

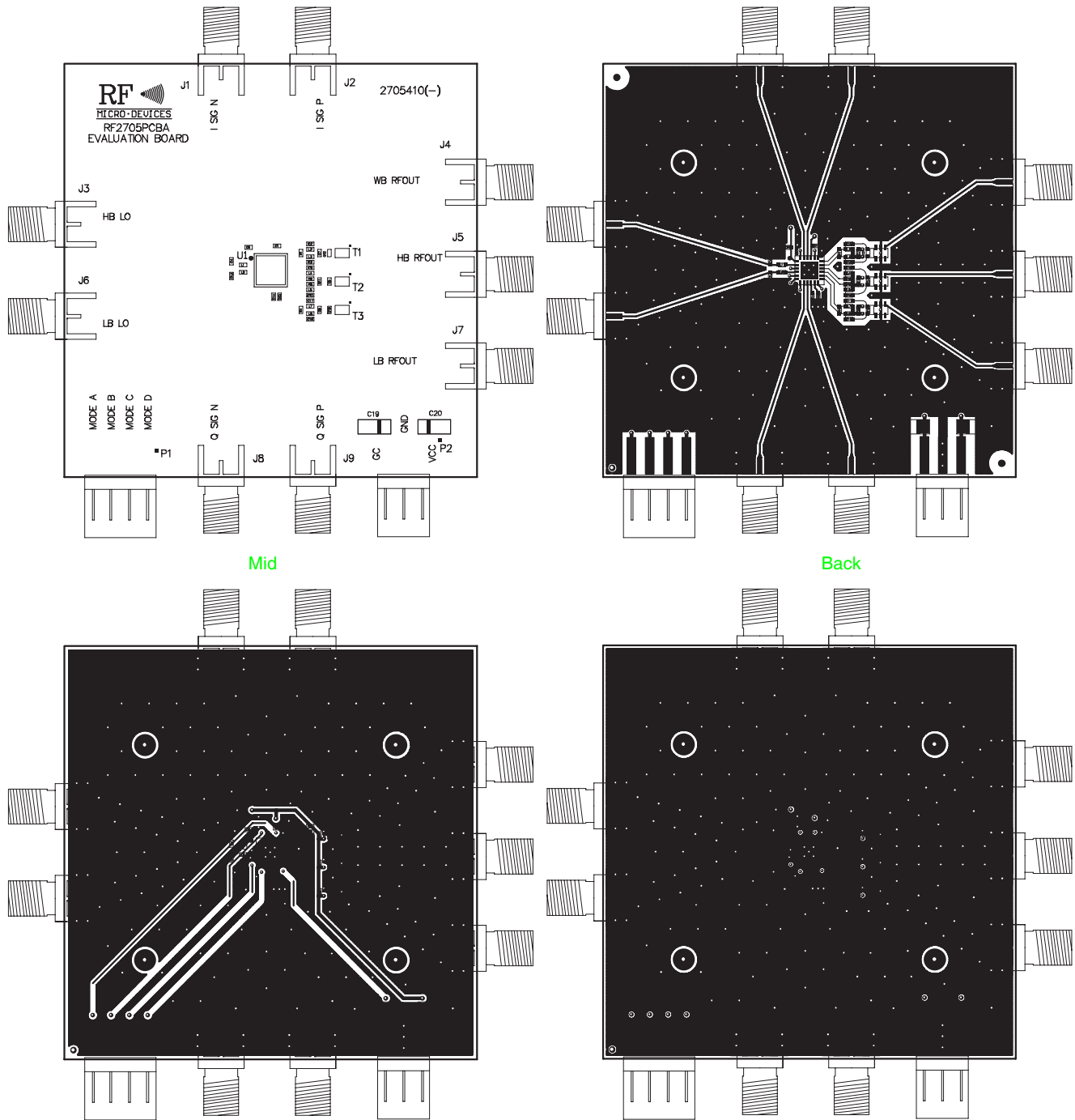

PCB Design Requirements

PCB Surface Finish

The PCB surface finish used for RFMD's qualification process is Electroless Nickel, immersion Gold. Typical thickness is 3µinch to 8µinch Gold over 180µinch Nickel.

PCB Land Pattern Recommendation

PCB land patterns are based on IPC-SM-782 standards when possible. The pad pattern shown has been developed and tested for optimized assembly at RFMD; however, it may require some modifications to address company specific assembly processes. The PCB land pattern has been developed to accommodate lead and package tolerances.

PCB Metal Land Pattern

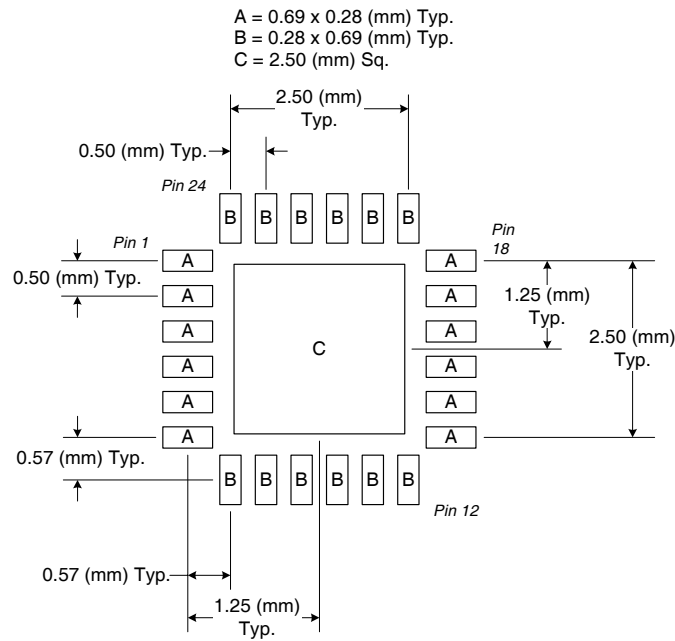

Figure 1. PCB Metal Land Pattern (Top View)

PCB Solder Mask Pattern

Liquid Photo-Imageable (LPI) solder mask is recommended. The solder mask footprint will match what is shown for the PCB Metal Land Pattern with a 2mil to 3mil expansion to accommodate solder mask registration clearance around all pads. The center-grounding pad shall also have a solder mask clearance. Expansion of the pads to create solder mask clearance can be provided in the master data or requested from the PCB fabrication supplier.

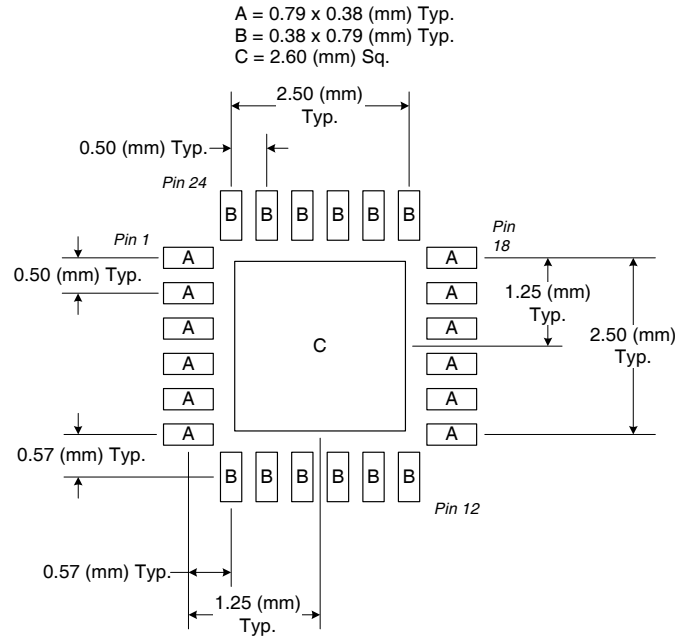

Figure 2. PCB Solder Mask Pattern (Top View)

Thermal Pad and Via Design

The PCB land pattern has been designed with a thermal pad that matches the exposed die paddle on the bottom of the device.

Thermal vias are required in the PCB layout to effectively conduct heat away from the package. The via pattern shown has been designed to address thermal, power dissipation and electrical requirements of the device as well as accommodating routing strategies.

The via pattern used for the RFMD qualification is based on thru-hole vias with 0.203mm to 0.330mm finished hole size on a 0.5mm to 1.2mm grid pattern with 0.025mm plating on via walls. If micro vias are used in a design, it is suggested that the quantity of vias be increased by a 4:1 ratio to achieve similar results.