

Package Style: QFN, 12-pin, 2mmx2mmx0.5mm



Features

- Single Supply Voltage 3.0V to 4.5V
- Integrated SP3T Switch and LNA with Bypass
- Typical Gain is 11dB and 2.0dB NF in RX Mode Pin-to-Pin
- SP3T Switch Control Voltage is 2.1V to 5V (3.0V Typical)

Applications

- IEEE802.11b/g/n WiFi Applications
- Portable Battery-Powered Equipment
- WiFi/Bluetooth® Combination Devices

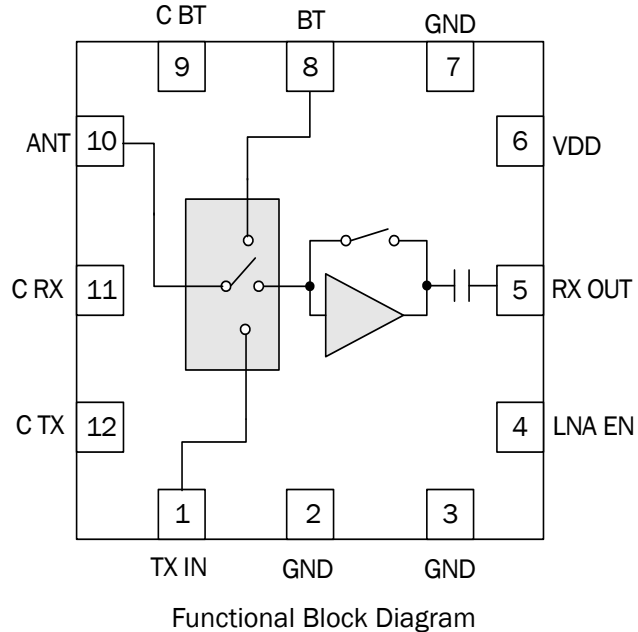

Product Description

The RF5501 is designed specifically for high-performance WiFi applications in the 2.4GHz to 2.5GHz ISM band, including Personal Media Players (PMPs), digital cameras, and WiFi enabled handsets.

The RF5501 integrates the LNA with bypass and an SP3T switch of a Front-End solution for WiFi and Bluetooth® combination systems. The integrated input and output match reduces the number of external components, keeping cost down and utilizing minimum layout area for implementation. The RF5501 is provided in a 2mmx2mmx0.5mm, 12-pin QFN package. This LNA + Switch front-end solution meets or exceeds the specification requirements of IEEE 802.11 b/g/n WiFi RF systems.

Ordering Information

RF5501	Standard 25 piece bag
RF5501SR	Standard 100 piece reel
RF5501TR7	Standard 2500 piece reel
RF5501PCK-410	Fully Assembled Evaluation Board

Optimum Technology Matching® Applied

- | | | | |
|--------------------------------------|--------------------------------------|--|-----------------------------------|
| <input type="checkbox"/> GaAs HBT | <input type="checkbox"/> SiGe BiCMOS | <input checked="" type="checkbox"/> GaAs pHEMT | <input type="checkbox"/> GaN HEMT |
| <input type="checkbox"/> GaAs MESFET | <input type="checkbox"/> Si BiCMOS | <input type="checkbox"/> Si CMOS | <input type="checkbox"/> RF MEMS |
| <input type="checkbox"/> InGaP HBT | <input type="checkbox"/> SiGe HBT | <input type="checkbox"/> Si BJT | <input type="checkbox"/> LDMOS |

RF MICRO DEVICES®, RFMD®, Optimum Technology Matching®, Enabling Wireless Connectivity™, PowerStar®, POLARIS™ TOTAL RADIO™ and UltimateBlue™ are trademarks of RFMD, LLC. BLUETOOTH is a trademark owned by Bluetooth SIG, Inc., U.S.A. and licensed for use by RFMD. All other trade names, trademarks and registered trademarks are the property of their respective owners. ©2006, RF Micro Devices, Inc.

Absolute Maximum Ratings

Parameter	Rating	Unit
DC Supply Voltage	5.5	V
Full Spec Compliant Temperature Range	-10 to +75	°C
Storage Temperature	-40 to +150	°C
Antenna Port Nominal Impedance	50	Ω
Stability Output VSWR	5:1	
ESD - Human Body Model	500	V
ESD - CDM	650	V
LNA Input Power (no damage)	5	dBm
Moisture Sensitivity	MSL2	



Caution! ESD sensitive device.

Exceeding any one or a combination of the Absolute Maximum Rating conditions may cause permanent damage to the device. Extended application of Absolute Maximum Rating conditions to the device may reduce device reliability. Specified typical performance or functional operation of the device under Absolute Maximum Rating conditions is not implied.

RoHS status based on EUDirective2002/95/EC (at time of this document revision).

The information in this publication is believed to be accurate and reliable. However, no responsibility is assumed by RF Micro Devices, Inc. ("RFMD") for its use, nor for any infringement of patents, or other rights of third parties, resulting from its use. No license is granted by implication or otherwise under any patent or patent rights of RFMD. RFMD reserves the right to change component circuitry, recommended application circuitry and specifications at any time without prior notice.

Parameter	Specification			Unit	Condition
	Min.	Typ.	Max.		
Compliance					IEEE802.11b, IEEE802.11g FCC CFR 15.247, .205, .209, EN & JDEC. V _{DD} = 3.3V, LNA EN = 2.85V, Temp = +25 °C, Freq = 2.4GHz to 2.5GHz, unless noted otherwise.
Operating Frequency	2.4		2.5	GHz	
LNA Voltage Supply (V _{DD})	3.0	3.3	4.5	V	
LNA Enable Voltage (LNA_EN)	2.7	2.85	4.5	V	LNA Enabled
			0.2	V	LNA Off
Switch Control Voltage "HIGH"	2.4		4.5	V	C_RX, C_TX, C_BT
Switch Control Voltage "LOW"			0.2	V	C_RX, C_TX, C_BT
LNA Bypass (LNA_EN)	2.7		4.5	V	LNA Bypass Disabled
			0.2	V	LNA Bypass Enabled
Current Consumption					
LNA V _{DD}		7	10.5	mA	LNA in "On" state
			10	μA	LNA in "Off" state
LNA Enable		1	1.5	mA	LNA Enabled
LNA Bypass			10	uA	LNA Bypass Mode
Switch Controls			10	uA	1-3uA per control line
Gain					
WiFi Receive	8	11	14	dB	C_RX _{HI} , C_TX _{LO} , C_BT _{LO} , LNA_EN _{HI}
WiFi RX Bypass	-5	-3.5		dB	LNA_EN < 0.2V
Simultaneous WiFi/BT Receive (note 4)	7	8		dB	Measured at RX OUT (LNA_EN _{HI} , C_RX _{HI} , C_BT _{HI} , C_TX _{LO})
	-5.0	-4		dB	Measured at BT Port (LNA_EN _{HI} , C_RX _{HI} , C_BT _{HI} , C_TX _{LO})

Parameter	Specification			Unit	Condition
	Min.	Typ.	Max.		
Insertion Loss					
WiFi Bypass (ANT to RX_OUT)		3.5	5.0	dB	C RX _{HI} , C TX _{LO} , C BT _{LO} , LNA EN _{LO}
BT (ANT to BT)		0.8	1.2	dB	C BT _{HI} , C RX _{LO} , C TX _{LO} , LNA EN _X
TX (TX_IN to ANT)		0.7	1.2	dB	C TX _{HI} , C RX _{LO} , C BT _{LO} , LNA EN _X
Simultaneous WiFi/BT Bypass (note 4)		6	7	dB	Measured at RX OUT (LNA EN _{LO} , C RX _{HI} , C BT _{HI} , C TX _{LO})
		4	5.0	dB	Measured at BT Port (LNA EN _{LO} , C RX _{HI} , C BT _{HI} , C TX _{LO})
Noise Figure					
WiFi Rx Mode		2.0	3.0	dB	Including switch, LNA EN _{HI}
BT		0.8	1.2	dB	
Simultaneous WiFi/BT RX (note 4)		4	5.0	dB	Measured at RX OUT (LNA EN _{HI} , C RX _{HI} , C BT _{HI} , C TX _{LO})
Input IP3	+1	+4		dBm	
Return Loss					
WiFi RX Mode	7.5	15		dB	Measured at RX OUT
BT	10	15		dB	Measured at BT Port
Transmit Port	10	15		dB	Measured at TX IN
Antenna Port (WiFi RX Mode)	7.5	11		dB	Measured at ANT Port under load conditions
Other Parameters					
Input/Output Impedance		50		Ω	All RF Ports (note 2)
Passband Ripple	-0.2		+0.2	dB	All modes
Switch P1dB		28		dBm	
Isolation					
TX to BT	25	29		dB	
TX to RX	20	23		dB	
Switch Control Speed		50		ns	(note 1)

Note 1: The switch must operate with gated bias voltage input at 1% to 99% duty cycle.
 Note 2: No external matching components.
 Note 3: Values to be agreed to upon characterization data review.
 Note 4: The FEM can be placed in receive WiFi and Bluetooth modes simultaneously with increased insertion loss.

Switch Control Logic

MODE	Switch Controls			
	C BT	C RX	C TX	LNA EN
WL RX	LOW	HIGH	LOW	HIGH
WiFi RX Bypass	LOW	HIGH	LOW	LOW
BT	HIGH	LOW	LOW	LOW
TX	LOW	LOW	HIGH	LOW
Simultaneous WL/BT RX	HIGH	HiGH	LOW	HIGH

Pin	Function	Description
1	TX IN	RF input for the 802.11b/g/n PA. Input is matched to 50Ω.
2	GND	Ground.
3	GND	Ground.
4	LNA EN	A logic HIGH enables the LNA.
5	RX OUT	Receive port for 802.11b/g/n. Internally matched to 50Ω. DC block provided internally.
6	VDD	Supply voltage to the LNA.
7	GND	Ground.
8	BT	RF bidirectional port for Bluetooth®. Input is matched to 50Ω.
9	C BT	Bluetooth® mode control voltage. See switch truth table for proper level.
10	ANT	This is the common port (antenna). It is matched at 50Ω.
11	C RX	Receive mode control voltage. See switch truth table for proper level.
12	C TX	Transmit mode control voltage. See switch truth table for proper level.

Package Drawing

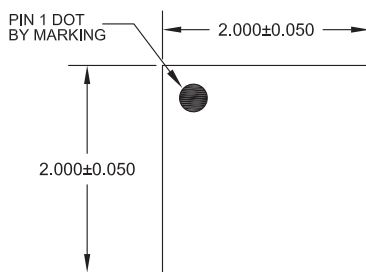

TOP VIEW

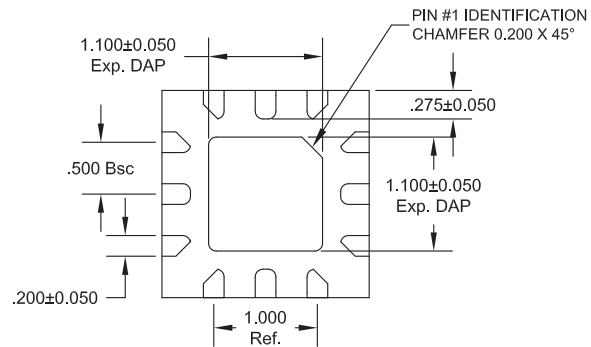

BOTTOM VIEW

A	ETSLP	
	MAX.	0.500
	NOM.	0.450
	MIN.	0.400

Notes:

- 1) Pin 1 Shaded Area

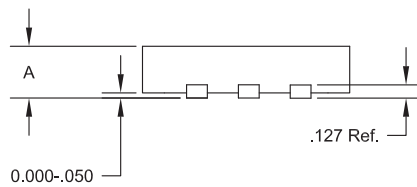

SIDE VIEW

PCB Metal Land Pattern

A = 0.230 x 0.378 (mm) Typ
 B = 0.378 x 0.230 (mm) Typ
 C = 0.230 x 0.378 (mm) Typ Octagon
 D = 0.378 x 0.230 (mm) Typ Octagon
 E = 1.100 (mm) Sq

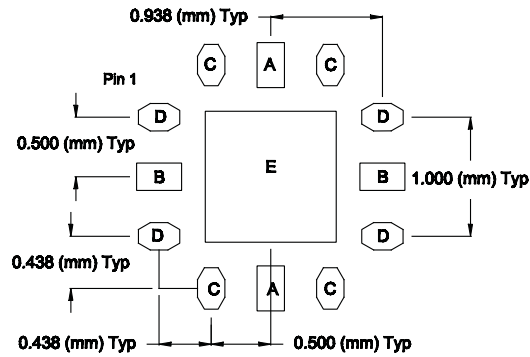

PCB Solder Mask Pattern

A = 0.330 x 0.478 (mm) Typ
 B = 0.478 x 0.330 (mm) Typ
 C = 0.330 x 0.478 (mm) Typ Octagon
 D = 0.478 x 0.330 (mm) Typ Octagon
 F = 1.200 (mm) Sq

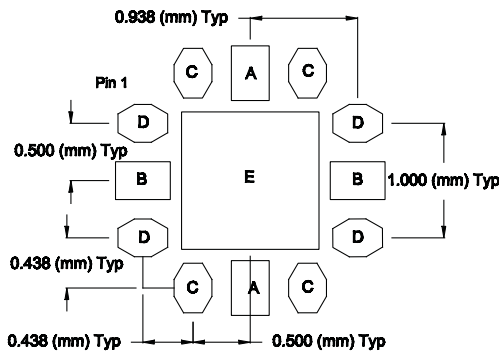

PCB Stencil Pattern

A = 0.207 x 0.340 (mm) Typ
 B = 0.340 x 0.207 (mm) Typ
 C = 0.207 x 0.340 (mm) Typ Octagon
 D = 0.340 x 0.207 (mm) Typ Octagon
 E = 0.990 (mm) Sq

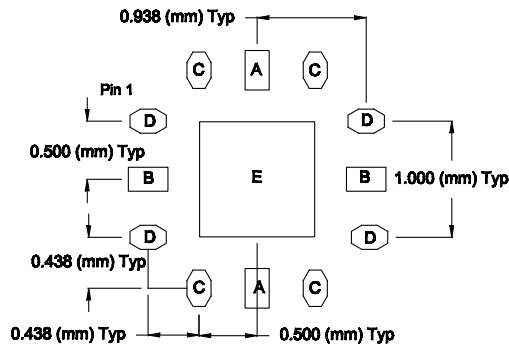

Pin Out Top View

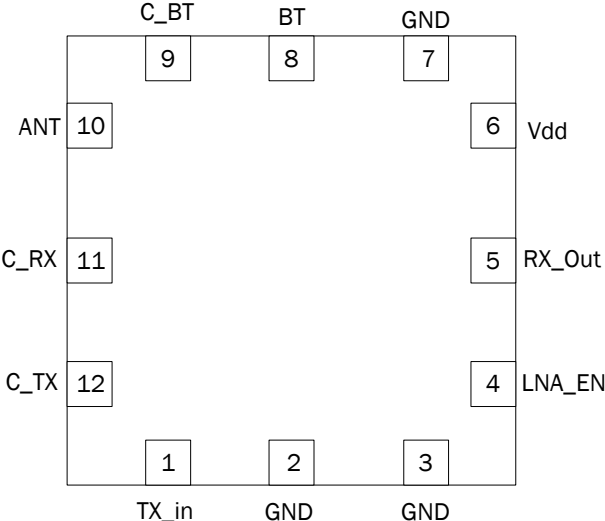

Evaluation Board Schematic

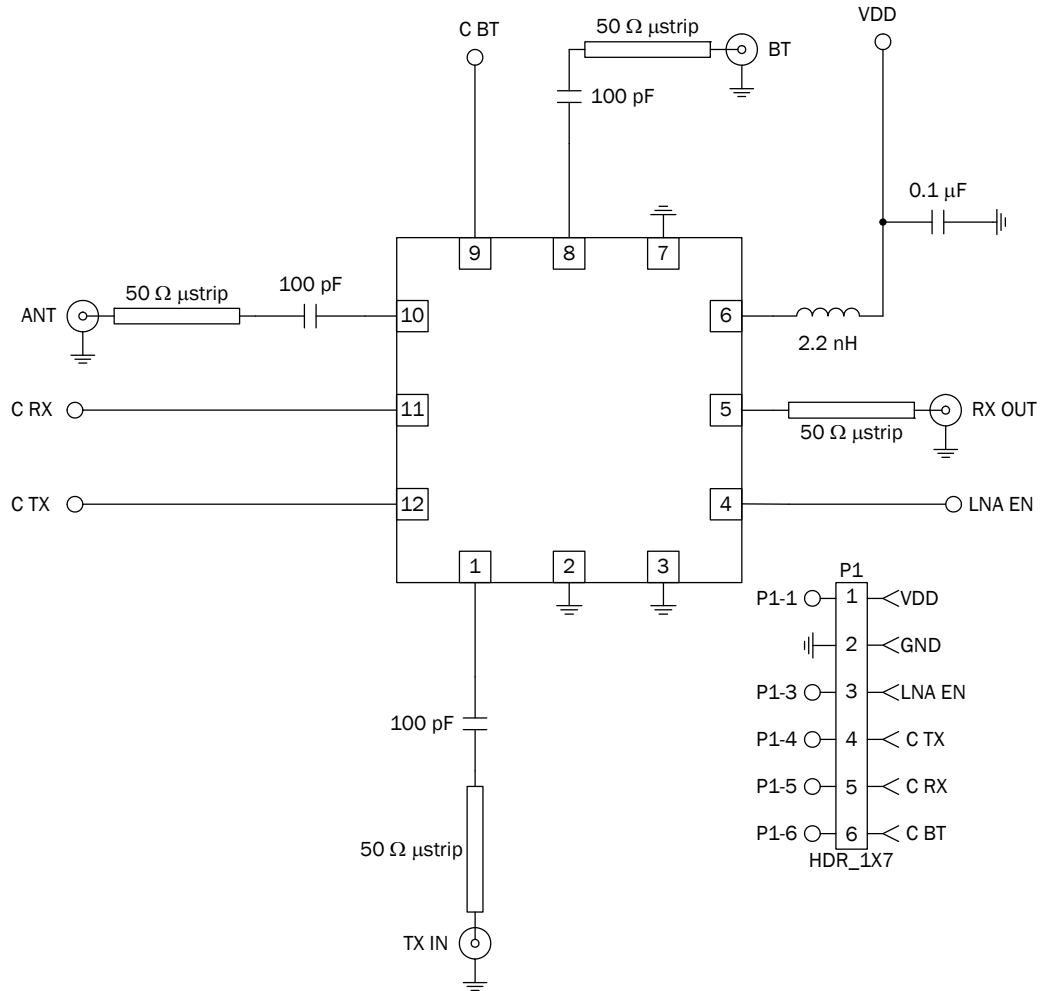

RF5501: GAIN versus FREQUENCY and TEMPERATURE
(Vdd=3.3v, LNA_EN=2.8v, C_RX=2.8v, C_TX=0v, C_BT=0v)

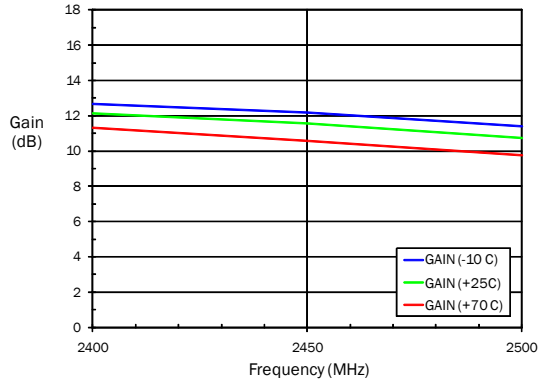

RF5501: NF versus FREQUENCY and TEMPERATURE
(Vdd=3.3v, LNA_EN=2.8v, C_RX=2.8v, C_TX=0v, C_BT=0v)

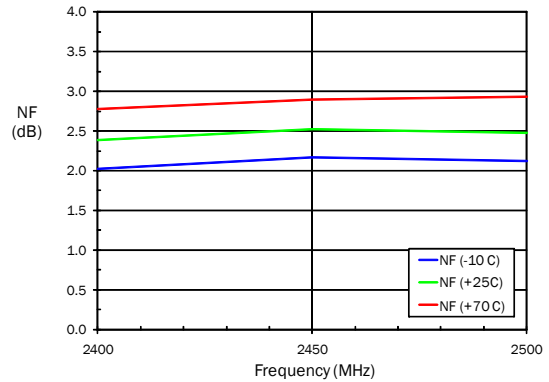

RF5501: INPUT IP3 versus FREQUENCY and TEMPERATURE
(Vdd=3.3v, LNA_EN=2.8v, C_RX=2.8v, C_TX=0v, C_BT=0v)

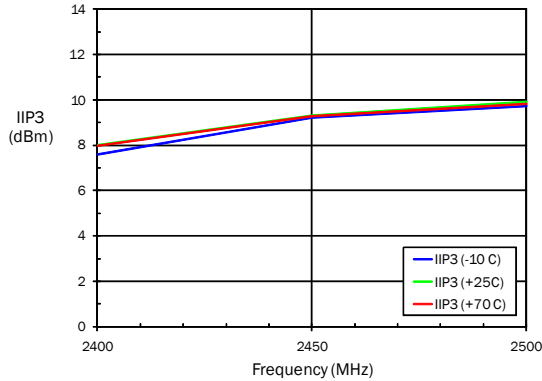

RF5501: CURRENT versus FREQUENCY and TEMPERATURE
(Vdd=3.3v, LNA_EN=2.8v, C_RX=2.8v, C_TX=0v, C_BT=0v)

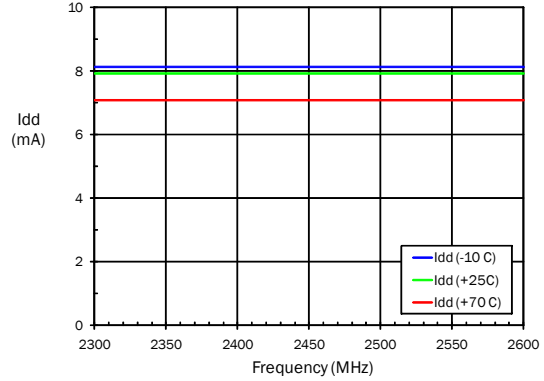

RF5501: BYPASS MODE INSERTION LOSS versus FREQUENCY and TEMPERATURE
(Vdd=3.3v, C_RX=2.8v, LNA_EN=0v, C_TX=0v, C_BT=0v)

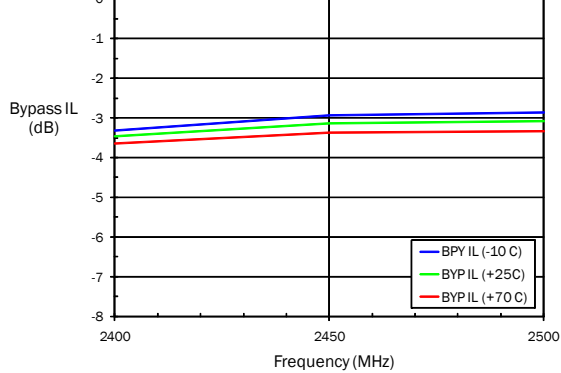

RF5501: TRANSMIT MODE INSERTION LOSS versus FREQUENCY and TEMPERATURE
(Vdd=3.3v, C_TX=2.8v, C_RX=0v, C_BT=0v)

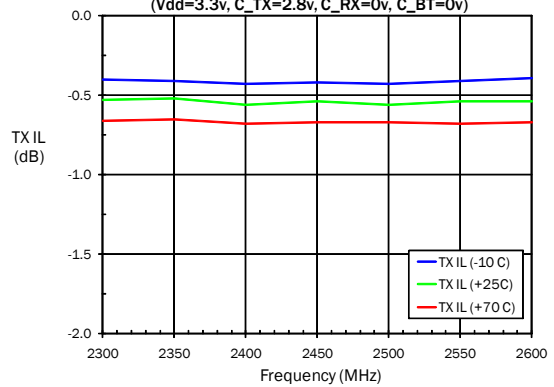

RF5501: BLUETOOTH MODE INSERTION LOSS versus FREQUENCY and TEMPERATURE

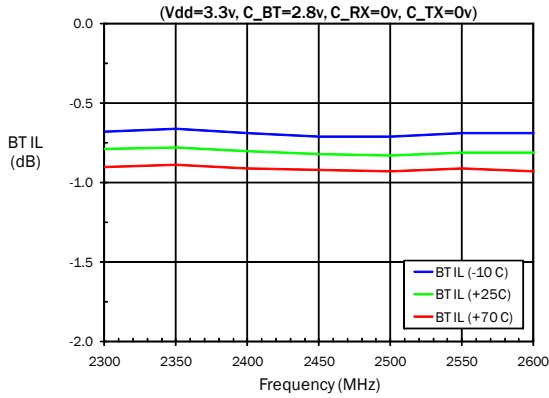

RF5501: TRANSMIT TO RECEIVE ISOLATION versus FREQUENCY and TEMPERATURE

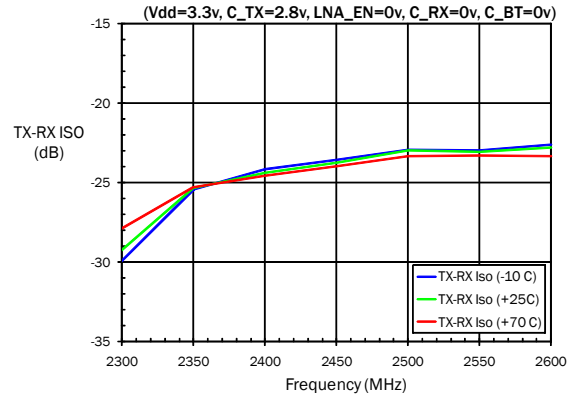

RF5501: TRANSMIT TO BLUETOOTH ISOLATION versus FREQUENCY and TEMPERATURE

