

Package: DFN, 8-Pin, 2.0mmx2.0mmx0.6mm



Features

- SP3T Switch
- Switch Control Voltage 2.5V to 5V
- Low Insertion Loss 0.6 dB

Applications

- IEEE802.11b/g/n WiFi Applications
- WiFi/Bluetooth® Combination Devices

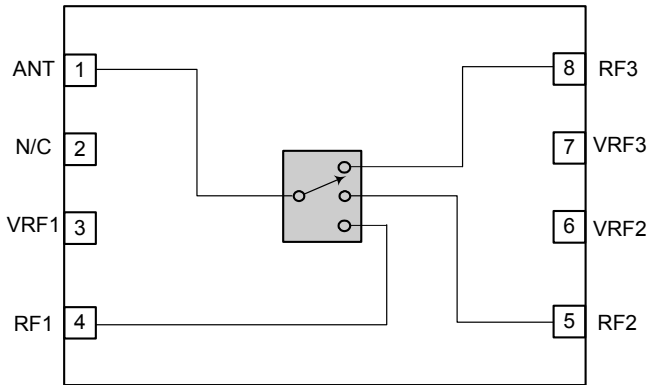

Functional Block Diagram

Product Description

The RF5570 is a SP3T switch designed for WiFi and WiFi/Bluetooth® applications in the 2.4GHz to 2.5GHz ISM band. The RF5570 is capable of switching between WiFi RX, WiFi TX, and Bluetooth® RX/TX operations. This switch can also be placed in WiFi and Bluetooth® receive modes simultaneously with a slight increase in insertion loss. The RF5570 is provided in a DFN 8-pin 2mmx2mmx0.6mm Pb-Free package. This device meets or exceeds the RF switch needs of IEEE802.11b/g/n RF systems.

Ordering Information

RF5570SQ	Standard 25-piece Bag
RF5570SR	Standard 100-piece Bag
RF5570TR7	Standard 2500-piece Reel
RF5570PCBK-410	Fully Assembled Evaluation Board with 5-piece Sample

Optimum Technology Matching® Applied

- | | | | |
|--------------------------------------|--------------------------------------|------------------------------------------------|-----------------------------------|
| <input type="checkbox"/> GaAs HBT | <input type="checkbox"/> SiGe BiCMOS | <input checked="" type="checkbox"/> GaAs pHEMT | <input type="checkbox"/> GaN HEMT |
| <input type="checkbox"/> GaAs MESFET | <input type="checkbox"/> Si BiCMOS | <input type="checkbox"/> Si CMOS | <input type="checkbox"/> RF MEMS |
| <input type="checkbox"/> InGaP HBT | <input type="checkbox"/> SiGe HBT | <input type="checkbox"/> Si BJT | <input type="checkbox"/> LDMOS |

RF MICRO DEVICES®, RFMD®, Optimum Technology Matching®, Enabling Wireless Connectivity™, PowerStar®, POLARIS™ TOTAL RADIO™ and UltimateBlue™ are trademarks of RFMD, LLC. BLUETOOTH is a trademark owned by Bluetooth SIG, Inc., U.S.A. and licensed for use by RFMD. All other trade names, trademarks and registered trademarks are the property of their respective owners. ©2006, RF Micro Devices, Inc.

Absolute Maximum Ratings

Parameter	Rating	Unit
Supply Voltage	5	V
Ruggedness Output VSWR	10:1	
Stability Output VSWR	5:1	
ESD Human Body Model	250	V
ESD Device Model	750	V
Operating Case Temperature	-40 to +85	°C
Storage Temperature	-40 to +150	°C
Moisture Sensitivity Level	MSL2	



Caution! ESD sensitive device.

Exceeding any one or a combination of the Absolute Maximum Rating conditions may cause permanent damage to the device. Extended application of Absolute Maximum Rating conditions to the device may reduce device reliability. Specified typical performance or functional operation of the device under Absolute Maximum Rating conditions is not implied.

The information in this publication is believed to be accurate and reliable. However, no responsibility is assumed by RF Micro Devices, Inc. ("RFMD") for its use, nor for any infringement of patents, or other rights of third parties, resulting from its use. No license is granted by implication or otherwise under any patent or patent rights of RFMD. RFMD reserves the right to change component circuitry, recommended application circuitry and specifications at any time without prior notice.



RFMD Green: RoHS compliant per EU Directive 2002/95/EC, halogen free per IEC 61249-2-21, < 1000ppm each of antimony trioxide in polymeric materials and red phosphorus as a flame retardant, and <2% antimony in solder.

Parameter	Specification			Unit	Condition
	Min.	Typ.	Max.		
2.4 GHz to 2.5 GHz Switch Transmit and Receive Parameters					Operating conditions, unless noted otherwise: Control voltage 2.5V to 5.0V; Temp = -40 °C to +85 °C
Frequency	2.4		2.5	GHz	
Insertion Loss		0.6	1.0	dB	All ports
Noise Figure		0.6	1.0	dB	All ports
Passband Ripple	-0.2		+0.2	dB	
Input IP3	34	45		dBm	All RF Modes; Over Temp Range
P1dB		28		dBm	3.1 or higher control voltage for 30dB min, 28 dB typical at 2.8V
Input Return Loss	15	18		dB	All RF Ports
Output Return Loss	15	18		dB	All RF Ports
Current Consumption		1	10	µA	Switch operating current, per control line
Port Impedance					All ports
Input		50		Ω	Receive
Output		50		Ω	Transmit
Isolation					All ports
RF1 Mode					Control Voltage 2.8 - 5.0V; over Temp and Freq
ANT-RF2	22	25	30	dB	
ANT-RF3	22	25		dB	
RF1-RF2	22	25		dB	
RF1-RF3	22	25		dB	
RF2 Mode					Control Voltage 2.8 - 5.0V; over Temp and Freq
ANT-RF1	21	23		dB	
ANT-RF3	22	25		dB	
RF2-RF1	22	23		dB	
RF2-RF3	21	25		dB	
RF3 Mode					Control Voltage 2.8 - 5.0V; over Temp and Freq
ANT-RF1	22	25		dB	
ANT-RF2	22	25		dB	
RF3-RF1	22	25		dB	
RF3-RF2	22	25		dB	
Switch Control Voltage					SW1, SW2, & SW3 pins
Low		0	.25	V	
High	2.5	2.8	5.0	V	
Switch Control Speed		150	500	nsec	10/90% or 90/10% Rise/Fall time

Pin	Function	Description
1	ANT	Antenna Port. External DC block required.
2	N/C	No Connect
3	VRF1	Switch control to enable RF1 to ANT
4	RF1	RF port. External DC block required.
5	RF2	RF port. External DC block required.
6	VRF2	Switch control to enable RF2 to ANT
7	VRF3	Switch control to enable RF3 to ANT
8	RF3	RF port. External DC block required.

Switch Control Logic

Mode	VRF1	VRF2	VRF3	Condition
RF3	0	0	1	RF3 to ANT
RF2	0	1	0	RF2 to ANT
RF1	1	0	0	RF1 to ANT
RF1/RF2	1	1	0	Simultaneous RF1 and RF2 to ANT
RF1/RF3	1	0	1	Simultaneous RF1 and RF3 to ANT
RF2/RF3	0	1	1	Simultaneous RF2 and RF3 to ANT

Pin Out



Application Schematic

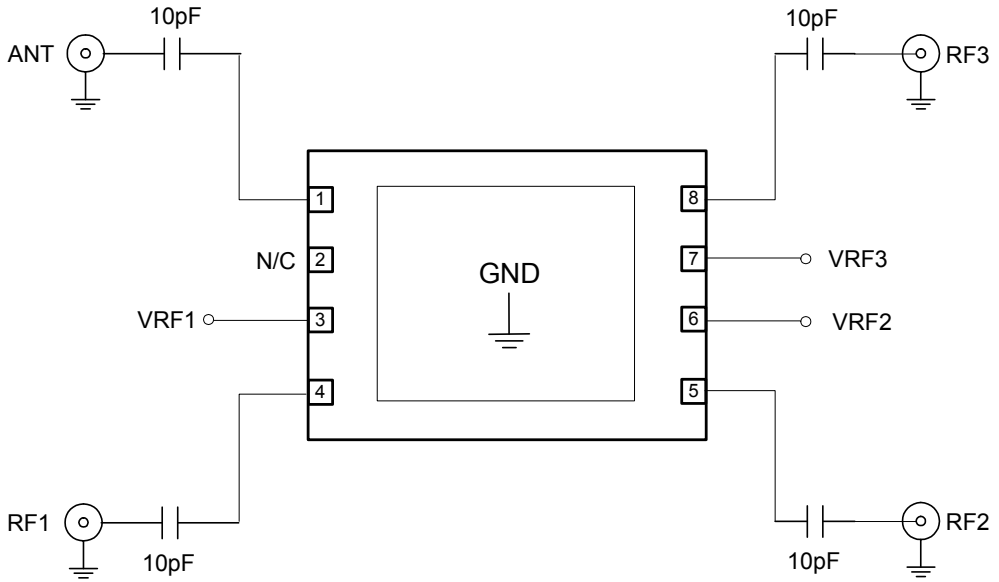

Package Drawing DFN, 8-Pin, 2mmx2mmx0.55mm

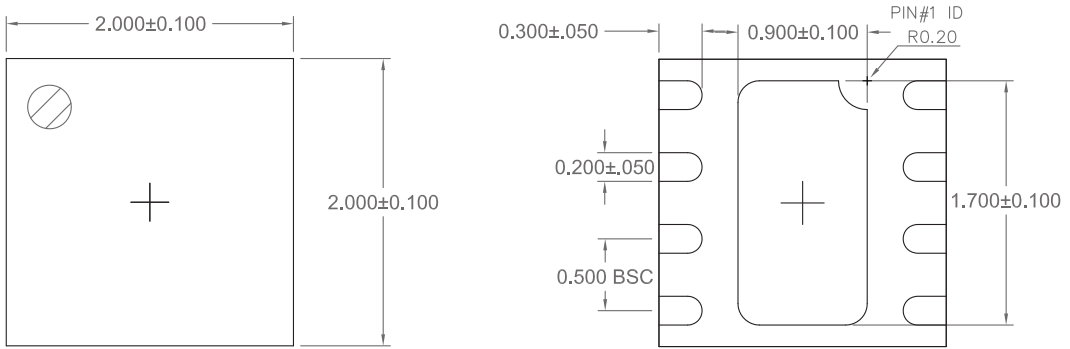

TOP VIEW

BOTTOM VIEW

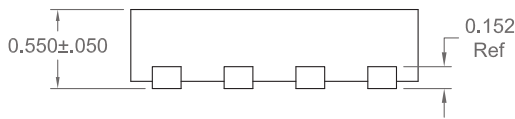

SIDE VIEW

Notes:

1. Shaded area represents Pin 1 location.

Recommended PCB Patterns

A = 0.428 x 0.250 (mm)
B = 0.900 x 1.700 (mm)

A = 0.548 x 0.370 (mm)
B = 1.020 x 1.820 (mm)

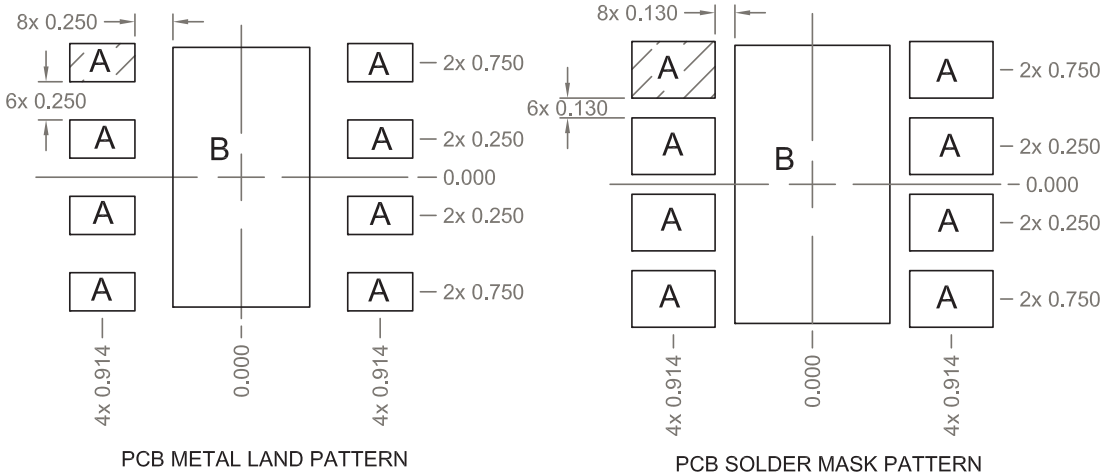

Shaded area represents Pin 1.

A = 0.385 x 0.225 (mm)
B = 0.810 x 1.530 (mm)

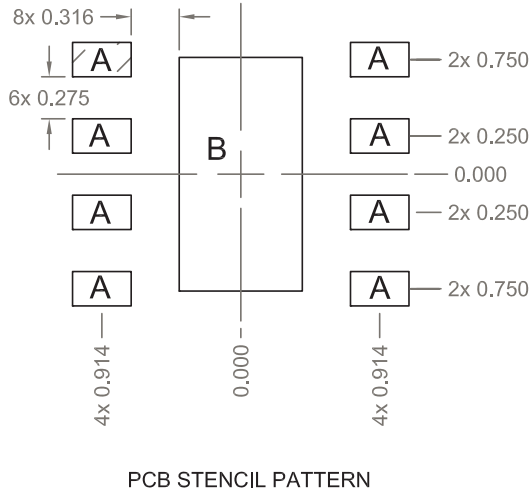

RF5570 Performance Plots

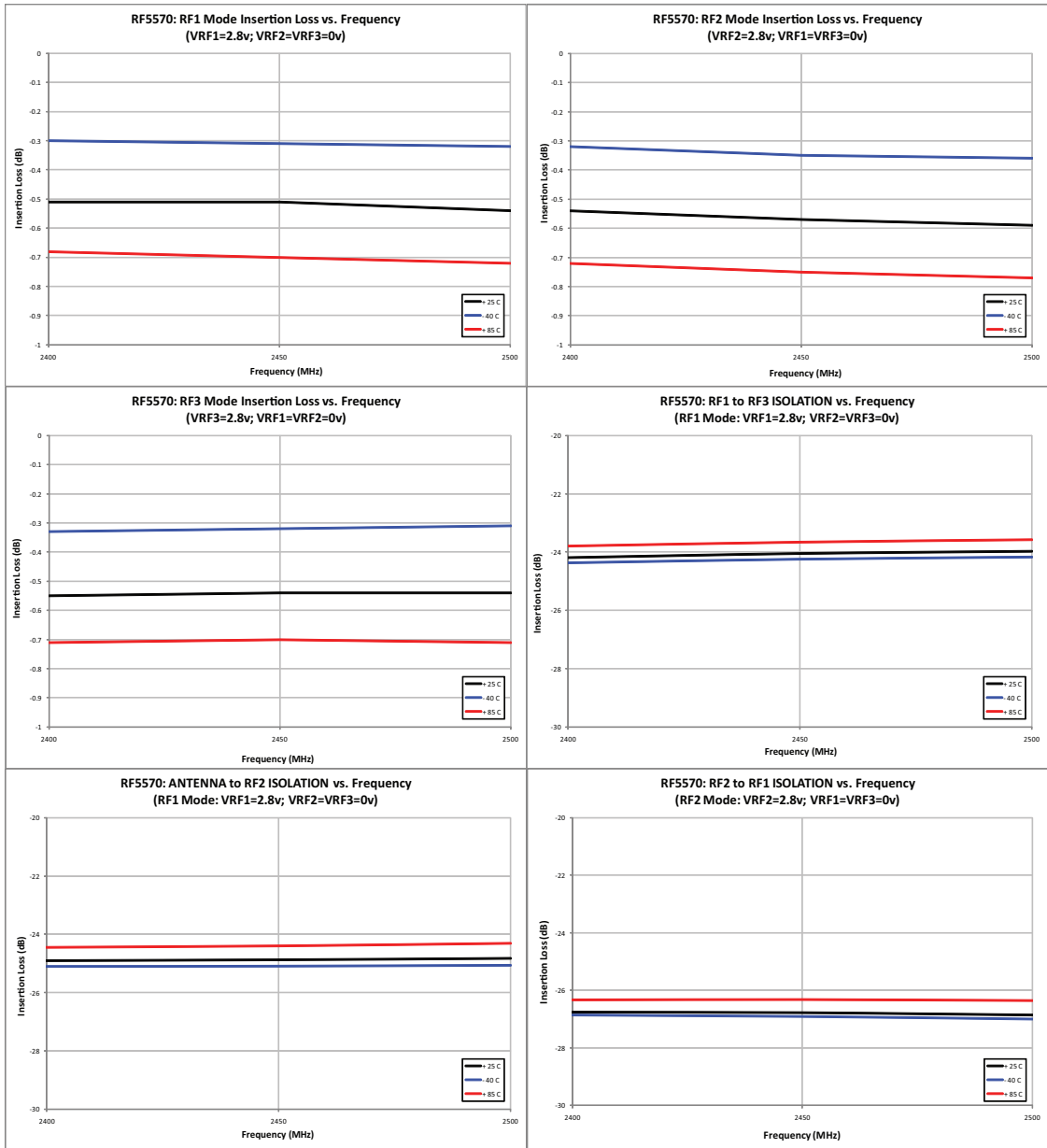

RF5570 Performance Plots

