

Package: S-20



**Features**

- Frequency Range 5MHz to 1200MHz
- Low Cost and RoHS Compliant
- Transmission Line
- Industry Standard SMT package
- Available in Tape-and -Reel
- 50Ω Characteristic Impedance

**Applications**

- Broadband/CATV
- Wireless

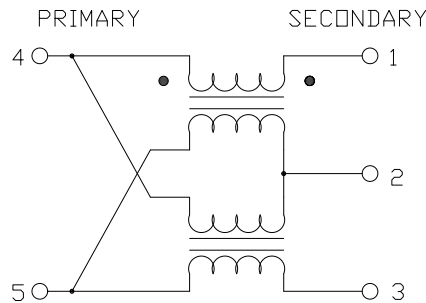

Schematic

**Product Description**

The RFXF5553 Transformer is designed for applications that require small, low cost, and highly reliable surface mount components. Applications may be found in broadband, wireless and other communications systems. These units are built Lead-Free and RoHS compliant. S-Parameters are available on request.

**Ordering Information**

Part Number	Description	Reel Size	Package
RFXF5553SB	5MHz to 1200MHz 1:4 SMT Transformer	N/A	5-piece bag
RFXF5553SQ	5MHz to 1200MHz 1:4 SMT Transformer	N/A	25-piece bag
RFXF5553SR	5MHz to 1200MHz 1:4 SMT Transformer	13"	100-piece reel
RFXF5553TR13	5MHz to 1200MHz 1:4 SMT Transformer	13"	1000-piece reel

**Optimum Technology Matching® Applied**

- |                                      |                                      |                                     |                                    |
|--------------------------------------|--------------------------------------|-------------------------------------|------------------------------------|
| <input type="checkbox"/> GaAs HBT    | <input type="checkbox"/> SiGe BiCMOS | <input type="checkbox"/> GaAs pHEMT | <input type="checkbox"/> GaN HEMT  |
| <input type="checkbox"/> GaAs MESFET | <input type="checkbox"/> Si BiCMOS   | <input type="checkbox"/> Si CMOS    | <input type="checkbox"/> BIFET HBT |
| <input type="checkbox"/> InGaP HBT   | <input type="checkbox"/> SiGe HBT    | <input type="checkbox"/> Si BJT     | <input type="checkbox"/> LDMOS     |

RF MICRO DEVICES®, RFMD®, Optimum Technology Matching®, Enabling Wireless Connectivity™, PowerStar®, POLARIS™ TOTAL RADIO™ and UltimateBlue™ are trademarks of RFMD, LLC. BLUETOOTH is a trademark owned by Bluetooth SIG, Inc., U.S.A. and licensed for use by RFMD. All other trade names, trademarks and registered trademarks are the property of their respective owners. ©2006, RF Micro Devices, Inc.

## Absolute Maximum Ratings

Parameter	Rating	Unit
RF Power	2	W
Operating Temperature	-45 to +85	°C
Storage Temperature	-55 to +100	°C



**Caution!** ESD sensitive device.

Exceeding any one or a combination of the Absolute Maximum Rating conditions may cause permanent damage to the device. Extended application of Absolute Maximum Rating conditions to the device may reduce device reliability. Specified typical performance or functional operation of the device under Absolute Maximum Rating conditions is not implied.

RoHS status based on EUDirective2002/95/EC (at time of this document revision).

The information in this publication is believed to be accurate and reliable. However, no responsibility is assumed by RF Micro Devices, Inc. ("RFMD") for its use, nor for any infringement of patents, or other rights of third parties, resulting from its use. No license is granted by implication or otherwise under any patent or patent rights of RFMD. RFMD reserves the right to change component circuitry, recommended application circuitry and specifications at any time without prior notice.

Parameter	Specification			Unit	Condition
	Min.	Typ.	Max.		
<b>Typical values represent Mid-Band performance at 25 °C</b>					
Frequency Range	5		1200	MHz	
Insertion Loss <1 dB	5		500	MHz	
Insertion Loss <2 dB	5		1200	MHz	
Insertion Loss <3 dB	-		-	MHz	
Amplitude Balance		0.2	0.5	dB	
Phase Balance		3	8	°	
Impedance Ratio	1:4				
Type - Transmission Line	Unbalanced to Balanced				

**Performance Plots**

**Input Return Loss**

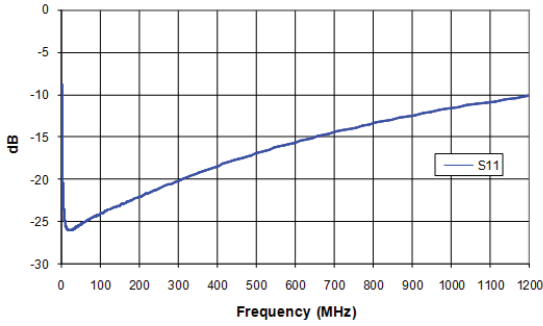

**Insertion Loss**

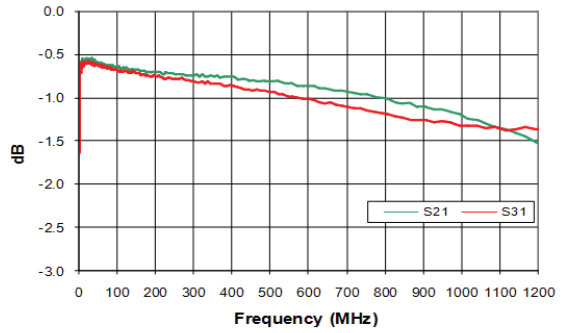

**Amplitude Balance**

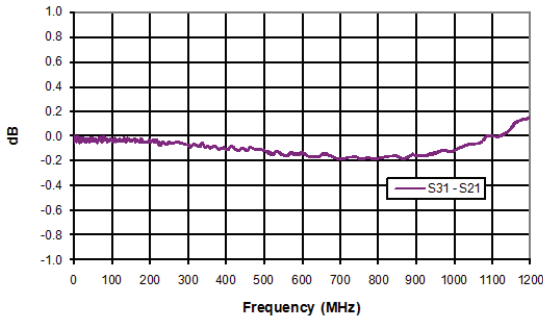

**Phase Balance**

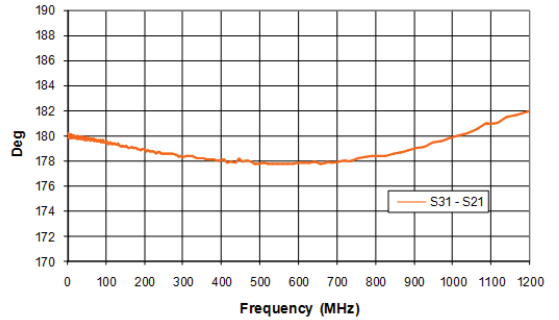

## Pin Out

Pin	Function
1	Secondary Dot
2	Secondary CT
3	Secondary
4	Primary Dot
5	Primary

## Package Drawing - S20

Dimensions in inches (millimeters)

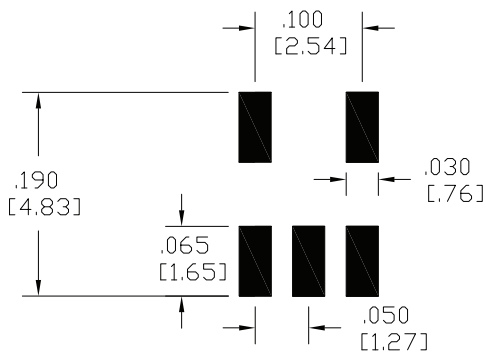
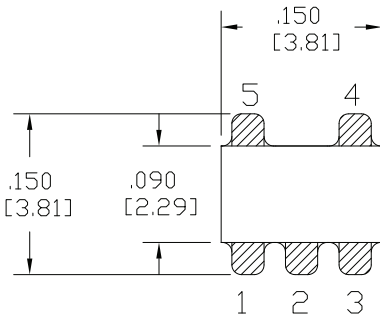

## PCB FOOTPRINT

