



Product Description

RFMD's SPB2026Z is a high linearity single-stage class AB Heterojunction Bipolar Transistor (HBT) amplifier housed in a surface-mountable plastic encapsulated package. This HBT amplifier is made with InGaP on GaAs device technology and fabricated with MOCVD for an ideal combination of low cost and high reliability. This product is well suited for use as a driver stage in macro/micro-cell infrastructure equipment or as the final output stage in pico-cell infrastructure equipment. It can run from a 3V to 6V supply. It is prematched to $\sim 5\Omega$ on the input for broadband performance and ease of matching at the board level. It features an input power detector, on/off power control, ESD protection, excellent overall robustness and a hand reworkable and thermally enhanced SOF-26 package. This product is RoHS and WEEE compliant.

Optimum Technology Matching® Applied

- GaAs HBT
- GaAs MESFET
- InGaP HBT
- SiGe BiCMOS
- Si BiCMOS
- SiGe HBT
- GaAs pHEMT
- Si CMOS
- Si BJT
- GaN HEMT
- RF MEMS

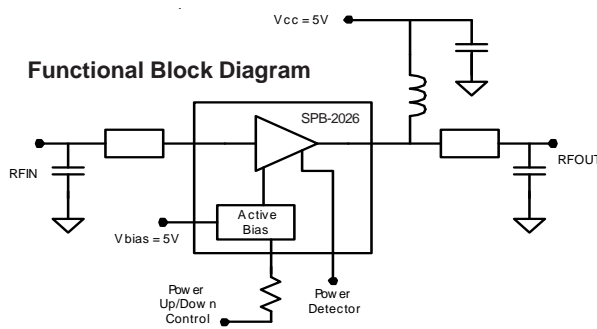

Features

- $P_{1dB} = 33.8\text{dBm}$ at 5V, 1960MHz
- ACP = -45 dBc with 25 dBm Channel Power at 1960MHz
- On-Chip Input Power Detector
- Low Thermal Resistance Package
- Power Up/Down Control <math>< 1\mu\text{s}</math>
- Robust Class 1C ESD

Applications

- Macro/Micro-Cell Driver Stage
- Pico-Cell Output Stage
- GSM, CDMA, TDSCDMA, WCDMA
- Single and Multi-Carrier Applications

Parameter	Specification			Unit	Condition
	Min.	Typ.	Max.		
Small Signal Gain		13.6		dB	1842MHz
	12.2	13.7	15.2	dB	1960MHz
	12.1	13.6	15.1	dB	2140MHz
Output Power at 1dB Compression		33.9		dBm	1842MHz
		33.8		dBm	1960MHz
	31.3	32.8		dBm	2140MHz
Third Order Supression		-49.0		dBc	1842MHz, 22dBm per tone, 1MHz spacing
	-42.0	-45.0		dBc	1960MHz, 22dBm per tone, 1MHz spacing
		-48.0		dBc	2140MHz, 22dBm per tone, 1MHz spacing
WCDMA Channel Power		-55.0		dBc ACP	1842MHz, tested with 64 Channels, FWD, 23dBm
		-55.0		dBc ACP	1960MHz, tested with 64 Channels, FWD, 23dBm
		-55.0	-48.0	dBc ACP	2140MHz, tested with 64 Channels, FWD, 23dBm
WCDMA Channel Power		-45.0		dBc ACP	1842MHz, 1960MHz, and 2140MHz. Tested with 64 Channels, FWD, 25dBm.
Input Return Loss	11.0	14.0		dB	1930MHz to 1990MHz
Output Return Loss	9.0	12.0		dB	1930MHz to 1990MHz
Noise Figure		5.2	6.2	dB	1960MHz
Voltage Range		0.85 to 1.4		V	CW $P_{OUT} = 13\text{dBm}$ to 33dBm
Thermal Resistance		12.0		$^{\circ}\text{C}/\text{W}$	junction - lead
Quiescent Current	380	445	500	mA	$V_{CC} = 5\text{V}$
Power up Control Current		2.1		mA	$V_{PC} = 5\text{V}$
V_{CC} Leakage Current			100	μA	$V_{CC} = 5\text{V}, V_{PC} = 0\text{V}$

Test Conditions: $V_{CC} = 5\text{V}, I_{CQ} = 445\text{mA}$ Typ., $T_L = 25^{\circ}\text{C}, Z_S = Z_L = 50\Omega$

RF MICRO DEVICES®, RFMD®, Optimum Technology Matching®, Enabling Wireless Connectivity™, PowerStar®, POLARIS™ TOTAL RADIO™ and UltimateBlue™ are trademarks of RFMD, LLC. BLUETOOTH is a trademark owned by Bluetooth SIG, Inc., U.S.A. and licensed for use by RFMD. All other trade names, trademarks and registered trademarks are the property of their respective owners. ©2006, RF Micro Devices, Inc.

Absolute Maximum Ratings

Parameter	Rating	Unit
Device Current (I_{CE})	1500	mA
*Device Voltage (V_{CC})	7	V
RF Input Power with 50Ω output load	28	dBm
RF Input Power with 10:1 VSWR output load	23	dBm
RF Output Power with 50Ω output load (Continuous long term operation)	30	dBm
Junction Temp (T_J)	+150	°C
Operating Temp Range (T_L)	-40 to +85	°C
Storage Temp	+150	°C
Power Dissipation (P_{DISS})	6	W
ESD Rating - Human Body Model (HBM)	Class 1C	
Moisture Sensitivity Level	MSL 1	

*Note: No RF Drive

Operation of this device beyond any one of these limits may cause permanent damage. For reliable continuous operation, the device voltage and current must not exceed the maximum operating values specified in the table on page one.

Bias Conditions should also satisfy the following expression:

$$I_D V_D < (T_J - T_L) / R_{TH}, j-I \text{ and } T_L = T_{LEAD}$$



Caution! ESD sensitive device.

Exceeding any one or a combination of the Absolute Maximum Rating conditions may cause permanent damage to the device. Extended application of Absolute Maximum Rating conditions to the device may reduce device reliability. Specified typical performance or functional operation of the device under Absolute Maximum Rating conditions is not implied.

RoHS status based on EU Directive 2002/95/EC (at time of this document revision).

The information in this publication is believed to be accurate and reliable. However, no responsibility is assumed by RF Micro Devices, Inc. ("RFMD") for its use, nor for any infringement of patents, or other rights of third parties, resulting from its use. No license is granted by implication or otherwise under any patent or patent rights of RFMD. RFMD reserves the right to change component circuitry, recommended application circuitry and specifications at any time without prior notice.

Simplified Device Schematic

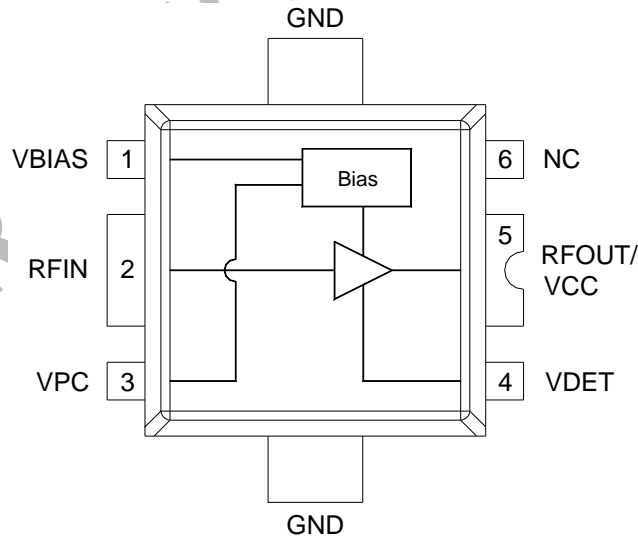

Typical RF Performance (1805MHz to 1880MHz Application Circuit)

Single Carrier ACP versus Channel Power
@1842MHz

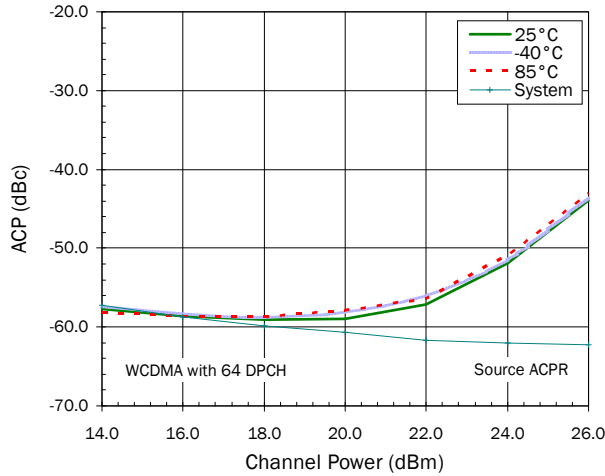

Dual Carrier ACP versus Channel Power
@1842MHz

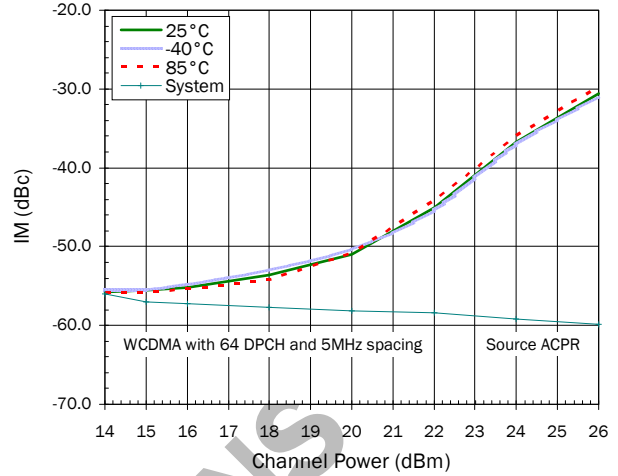

IM3 versus Frequency
(22dBm Output Tones)

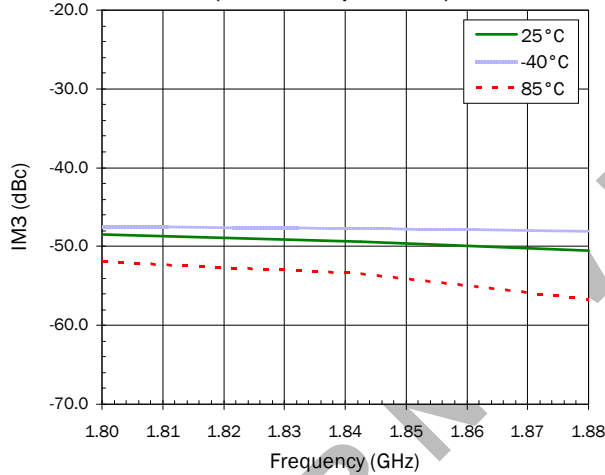

IM3 versus Tone Power @ 1842MHz

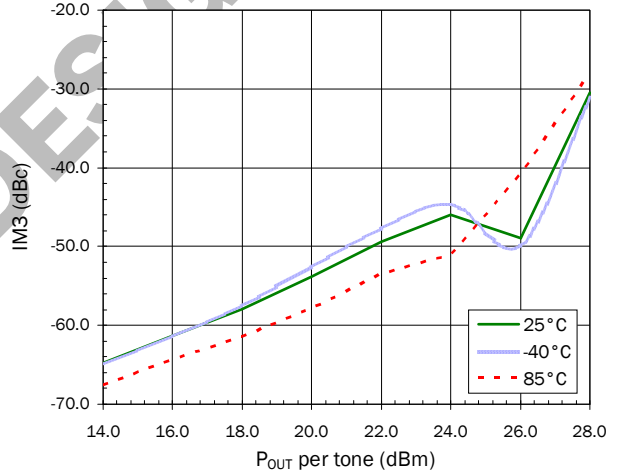

Typical RF Performance (1805MHz to 1880MHz Application Circuit)

P_{1dB} versus Frequency

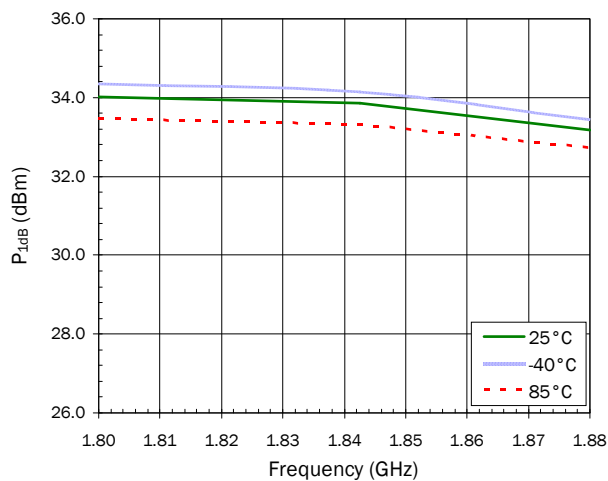

P_{IN} versus P_{OUT} @ 1842MHz

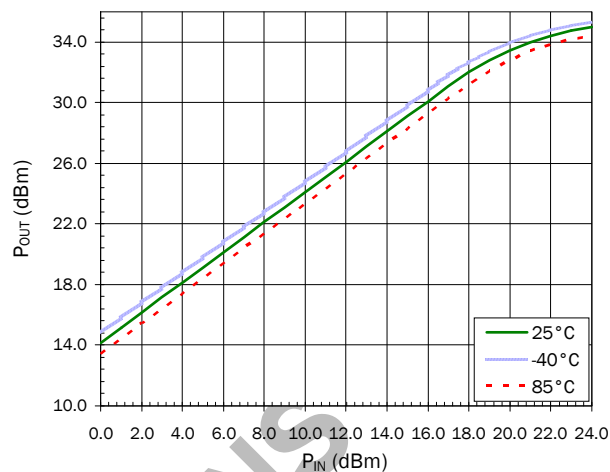

Noise Figure vs. Frequency

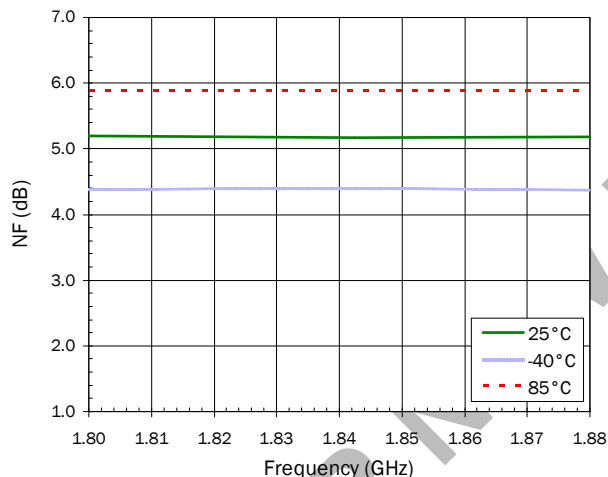

V_{DETECT} versus P_{OUT} @ 1842MHz

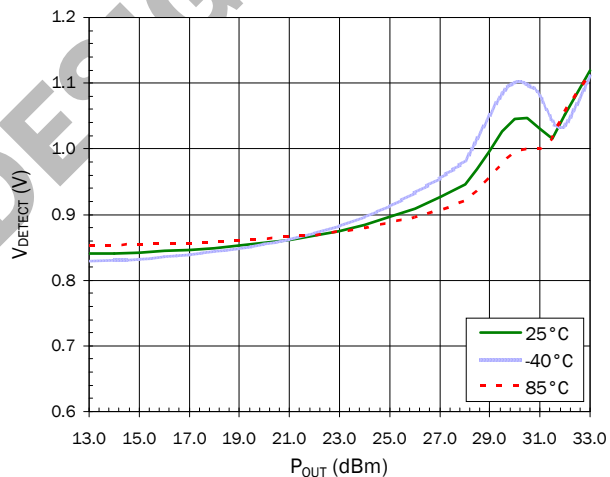

S-Parameters Over Temperature (1805MHz to 1880MHz Application Circuit)

S11 over Temperature

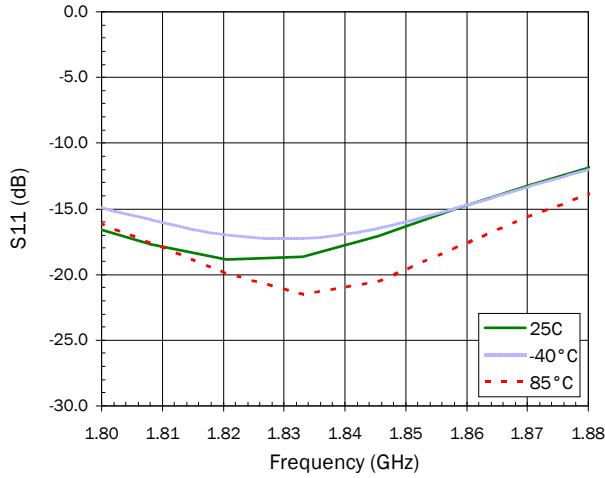

S21 over Temperature

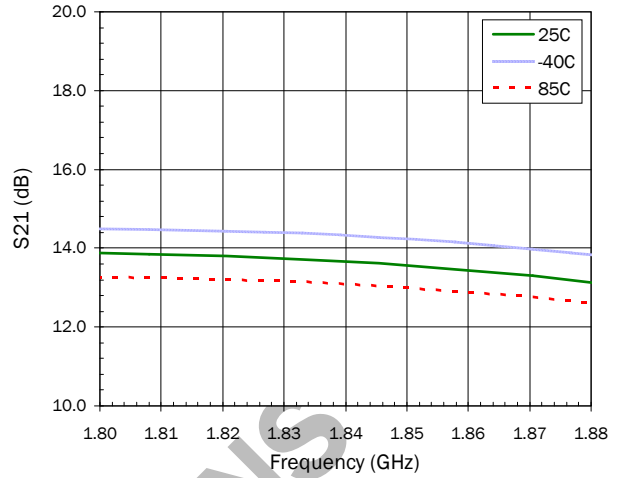

S12 over Temperature

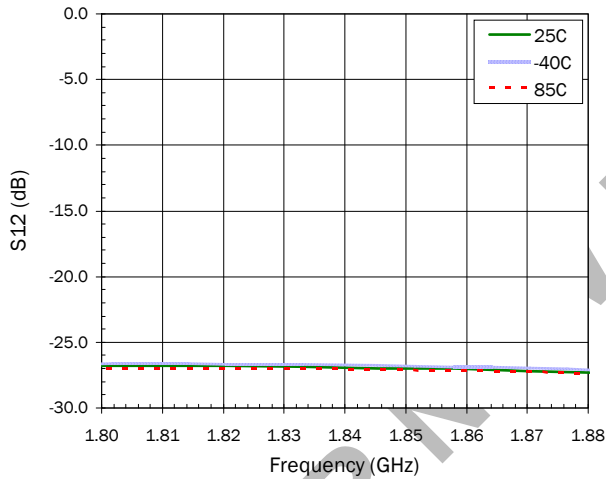

S22 over Temperature

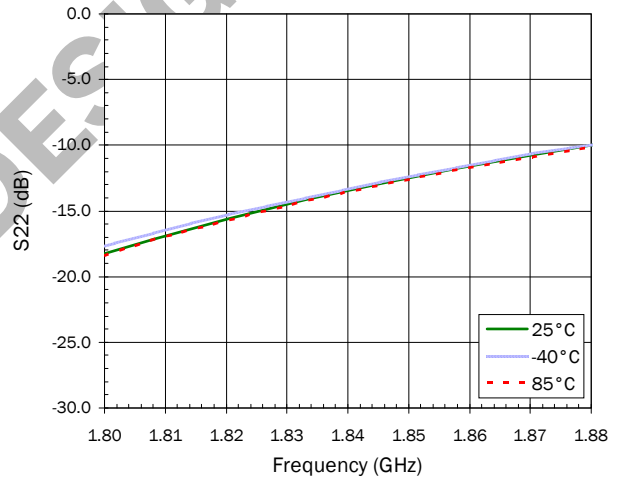

Typical RF Performance (1930MHz to 1990MHz Application Circuit)

Single Carrier ACP versus Channel Power @ 1960MHz

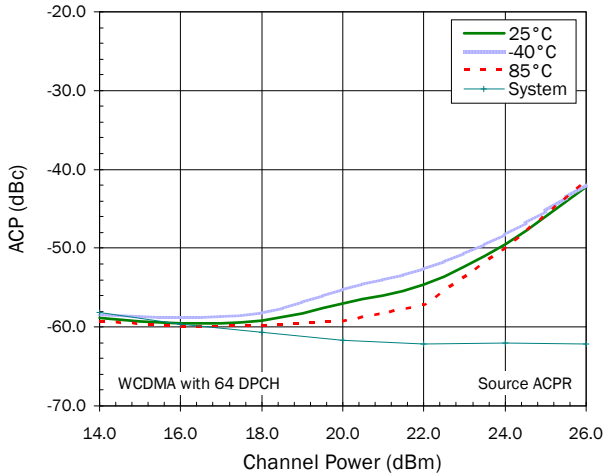

Dual Carrier ACP versus Channel Power @ 1960MHz

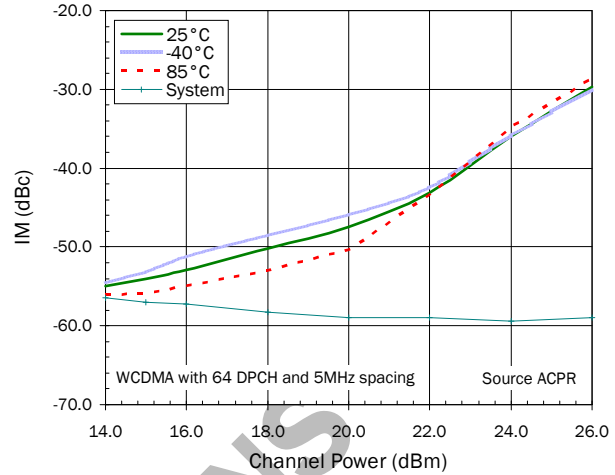

IM3 versus Frequency (22dBm Output Tones)

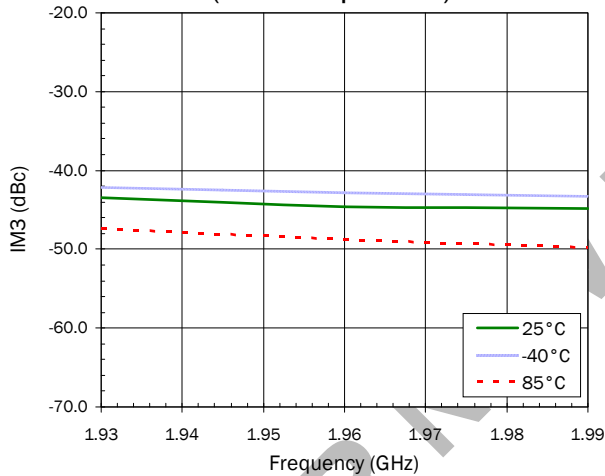

IM3 versus Tone Power @ 1960MHz

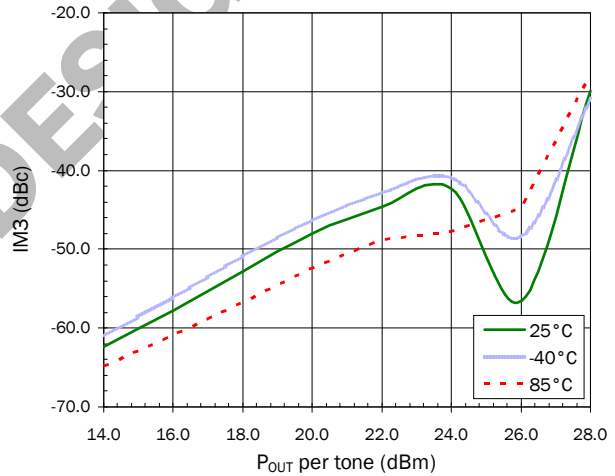

NOT FOR PRODUCTION DESIGNS

Typical RF Performance (1930MHz to 1990MHz Application Circuit)

P_{1dB} versus Frequency

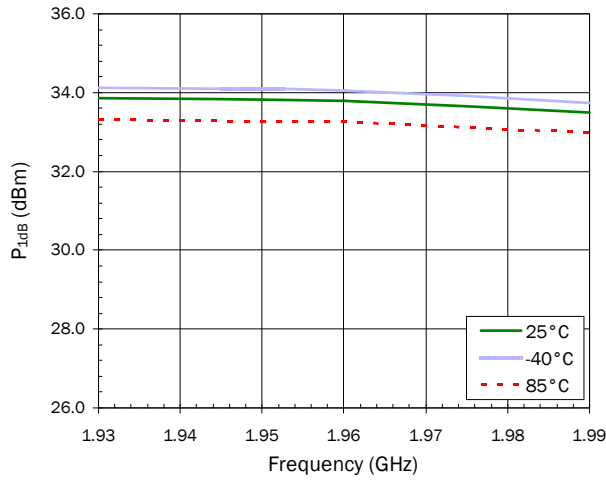

P_{IN} versus P_{OUT} @ 1960MHz

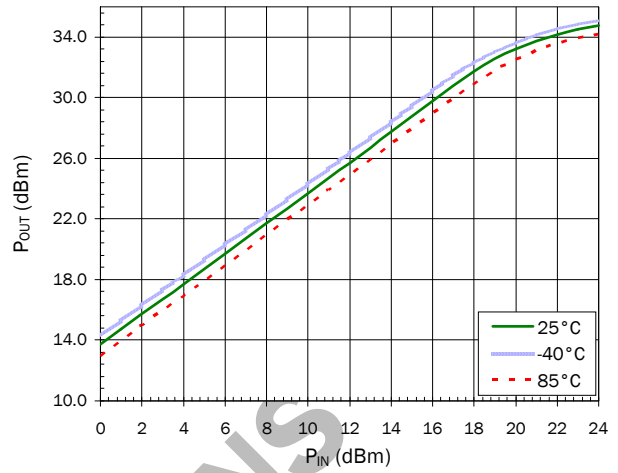

Noise Figure versus Frequency

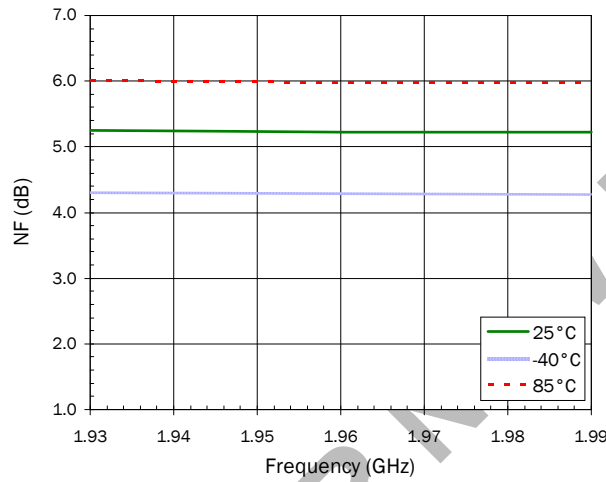

V_{DETECT} versus P_{OUT} @ 1960MHz

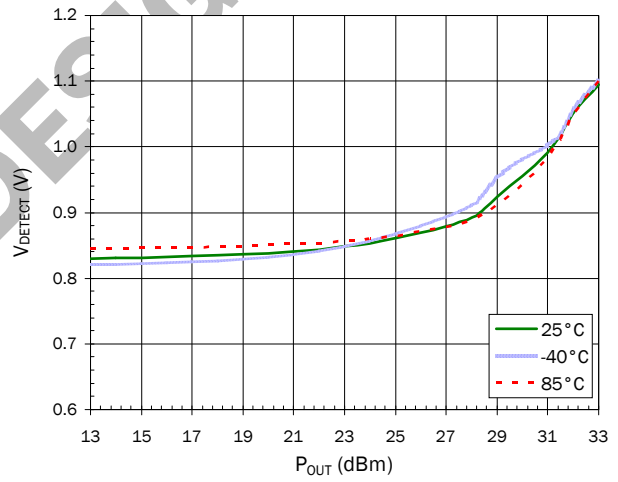

S-Parameters over Temperature (1930MHz to 1990MHz Application Circuit)

S11 over Temperature

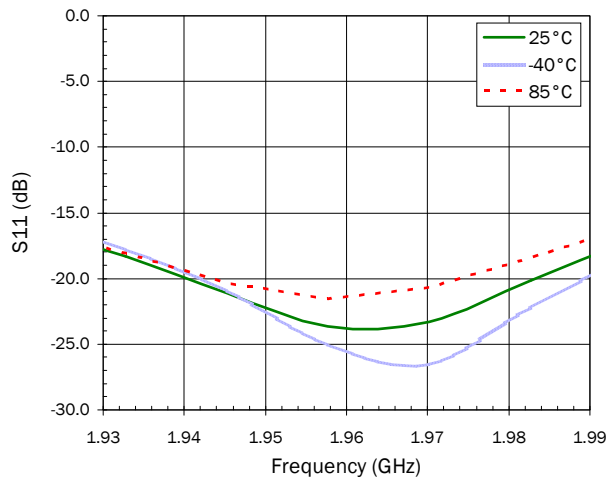

S21 over Temperature

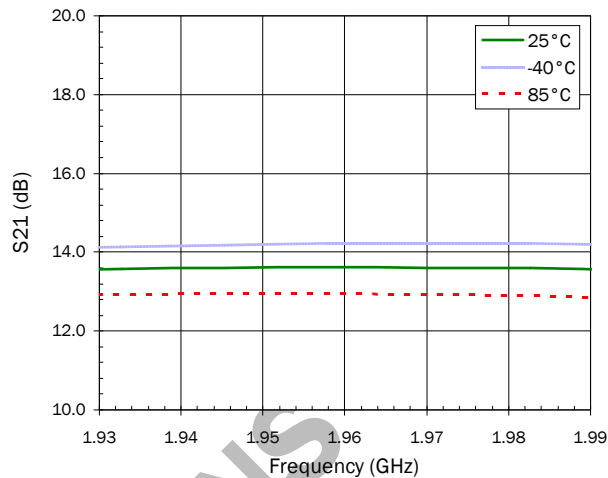

S12 over Temperature

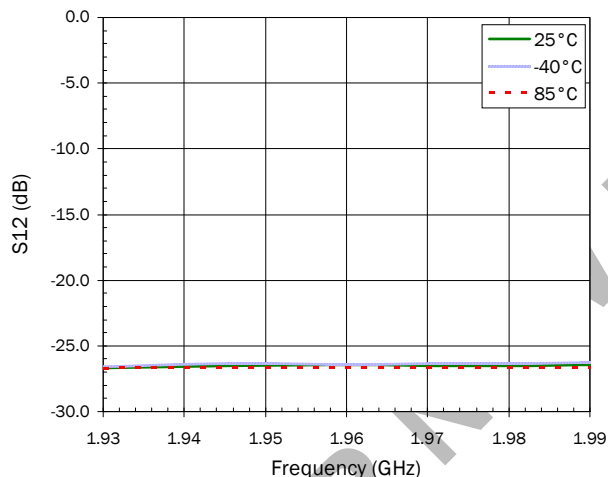

S22 over Temperature

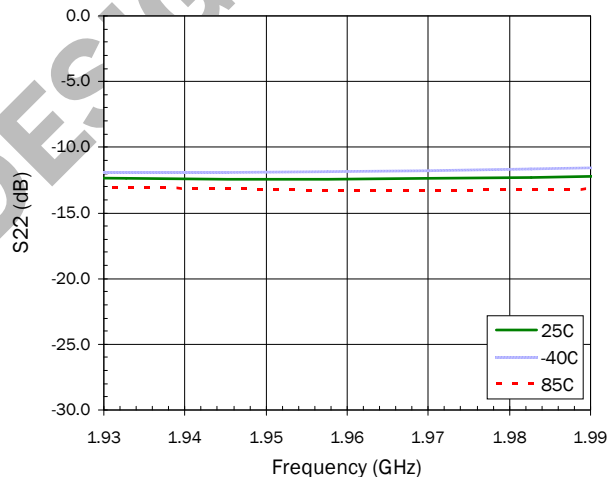

Typical RF Performance (2110MHz to 2170MHz Application Circuit)

Single Carrier ACP versus Channel Power @ 2140MHz

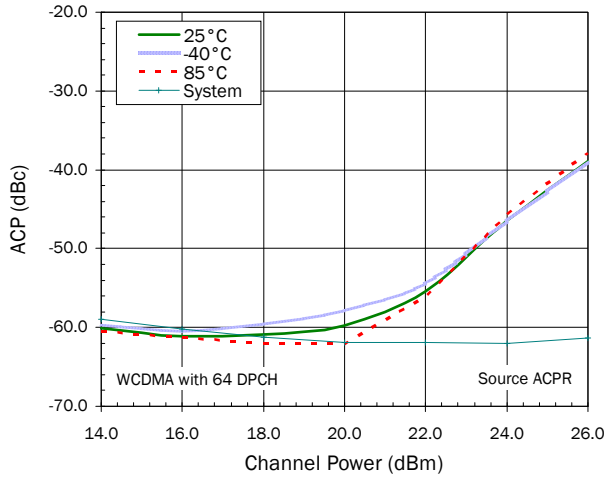

Dual Carrier ACP versus Channel Power @ 2140MHz

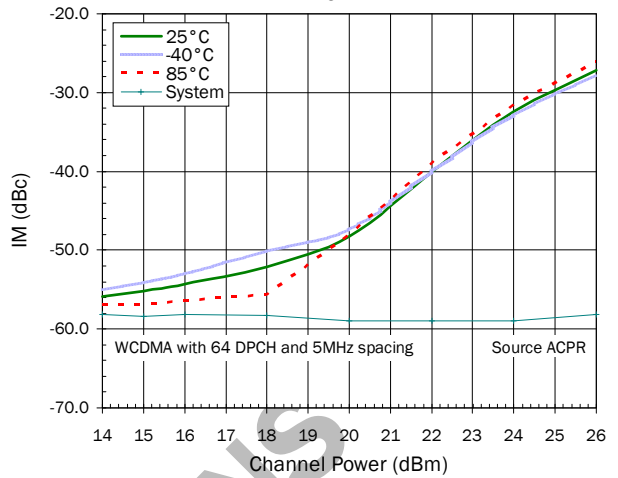

IM3 versus Frequency (22dBm Output Tones)

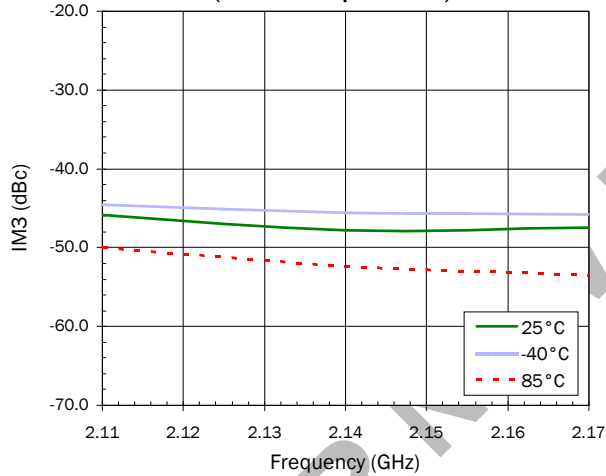

IM3 versus Tone Power @ 2140MHz

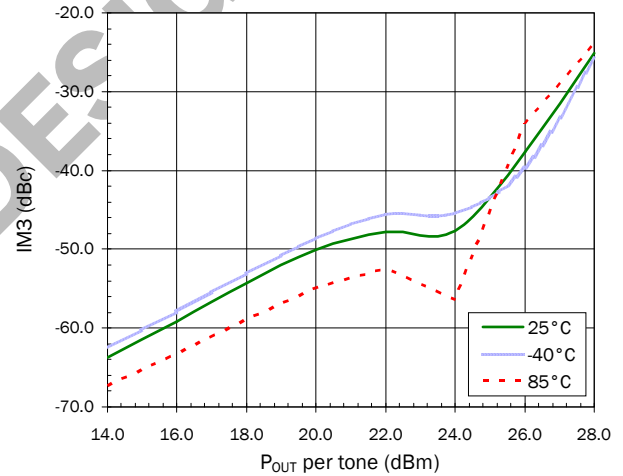

Typical RF Performance (2110MHz to 2170MHz Application Circuit)

P_{1dB} versus Frequency

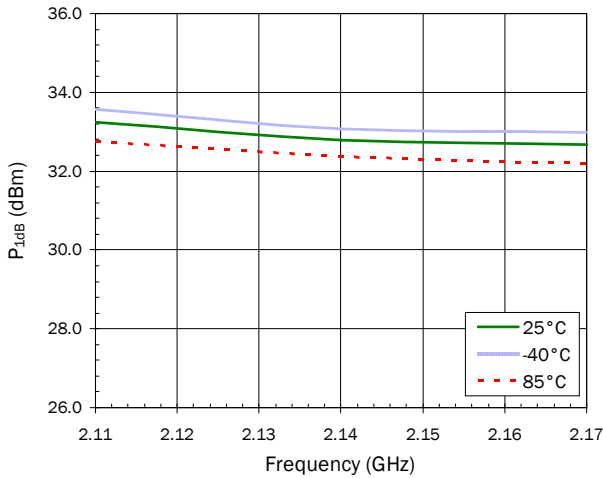

P_{IN} versus P_{OUT} @ 2140MHz

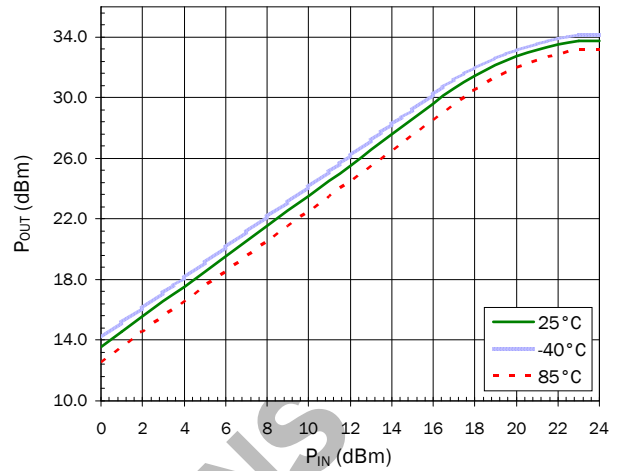

Noise Figure vs. Frequency

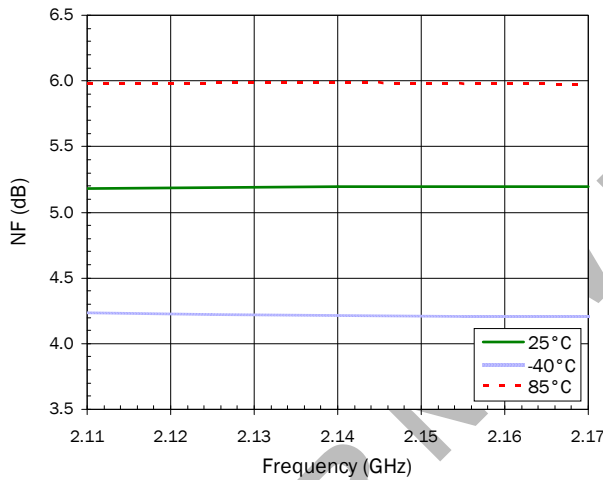

V_{DETECT} versus P_{OUT} @ 2140MHz

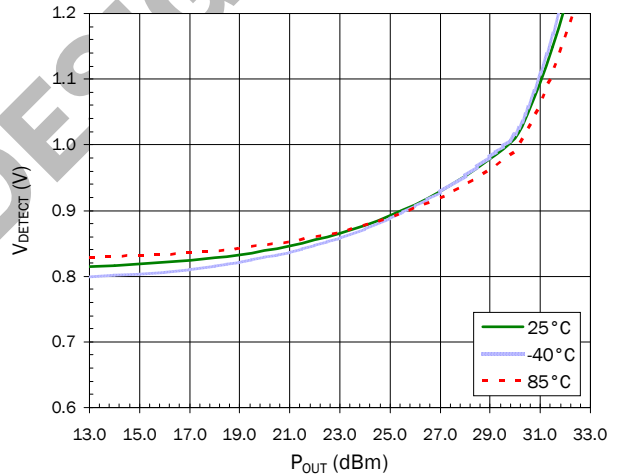

S-Parameters over Temperature (2110MHz to 2170MHz Application Circuit)

S11 over Temperature

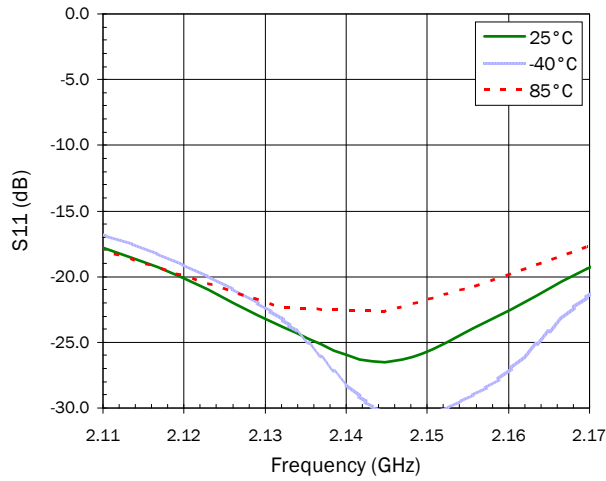

S21 over Temperature

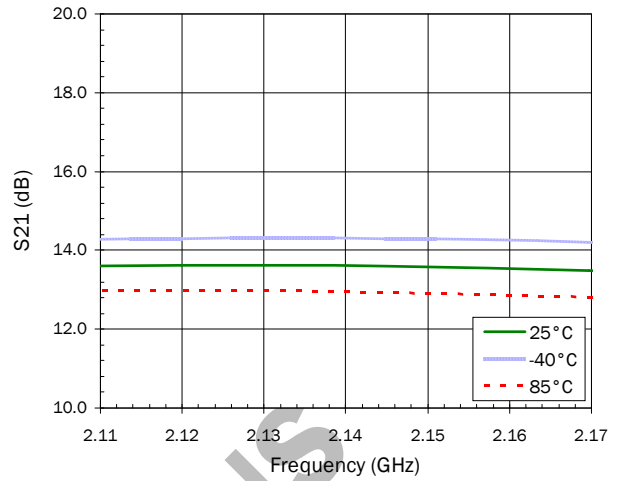

S12 over Temperature

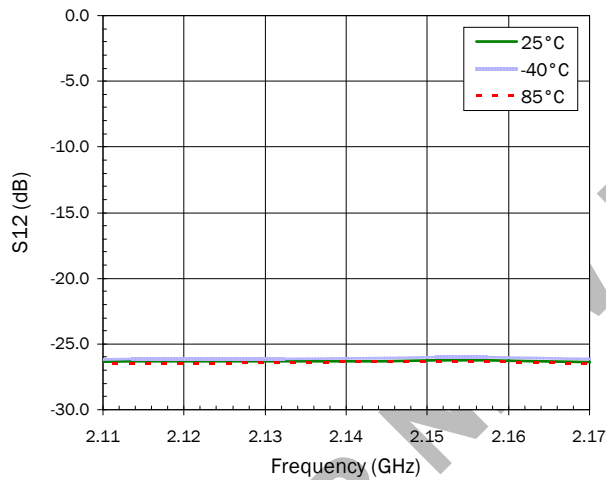

S22 over Temperature

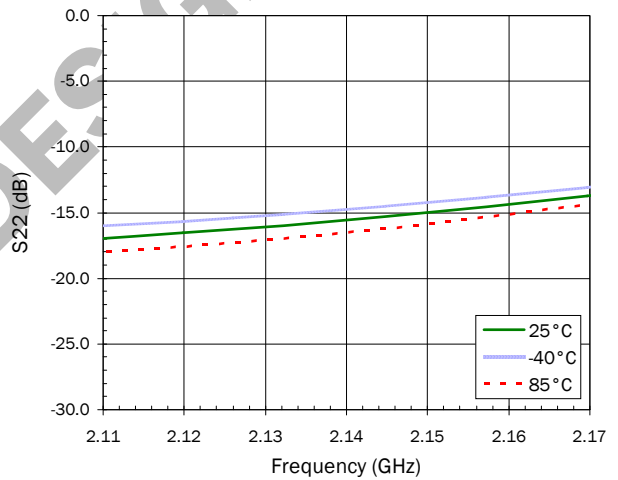

Pin	Function	Description
1	VBIAS	This is the supply voltage for the active bias circuit.
2	RF IN	This is the RF input pin and has a DC voltage present. An external DC block is required.
3	VPC	Power up/down control pin. The voltage on this pin should never exceed the voltage on pin 1 by more than 0.5V unless the supply current from pin 3 is limited < 10mA.
4	VDET	This is the output port for the power detector. It samples the power at the input of the amplifier.
5	RF OUT/VCC	This is the RF output pin and DC connection to the collector.
6	NC	Not connected
GND	GND	These pins are DC connected to the backside paddle. They provide good thermal connection to the backside paddle for hand soldering and rework. Many thermal and electrical GND vias are required as shown in the recommended land pattern.

Suggested Pad Layout

Dimensions in millimeters (inches)

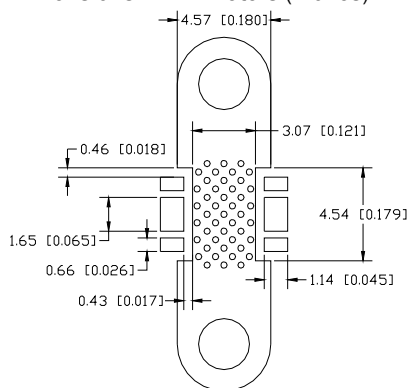

Package Drawing

Dimensions in millimeters (inches)

Refer to drawing posted at www.rfmd.com for tolerances.

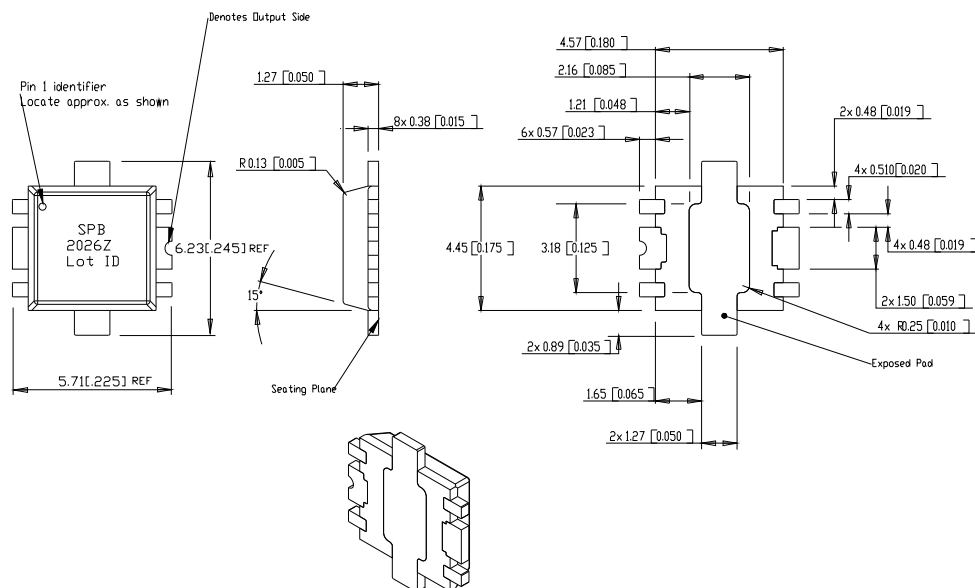

1805 MHz to 1880 MHz Application Schematic

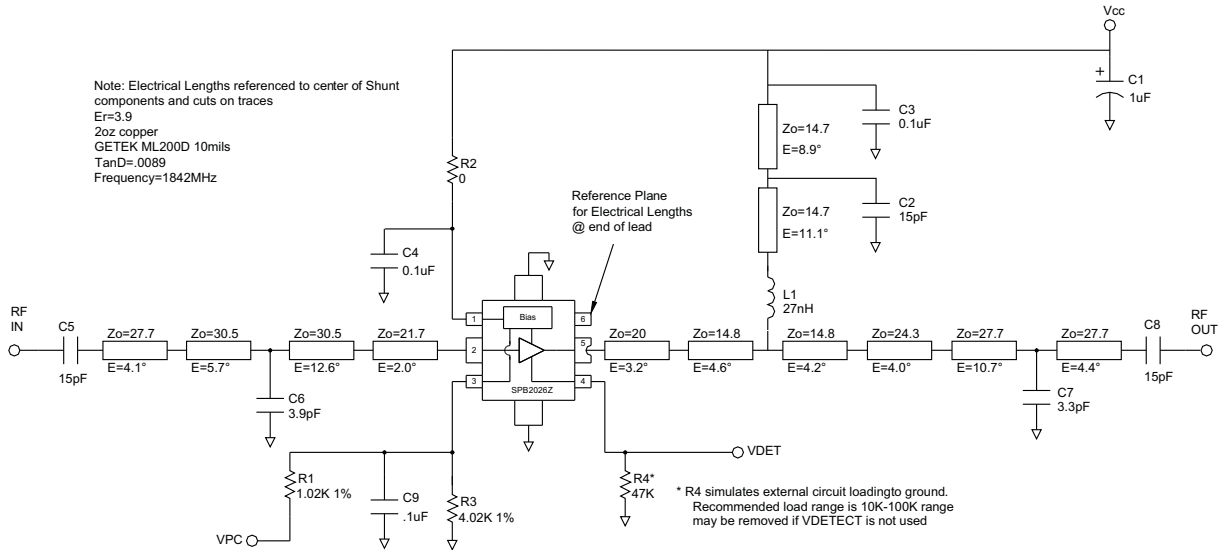

1805MHz to 1880 MHz Evaluation Board Layout and Bill of Materials

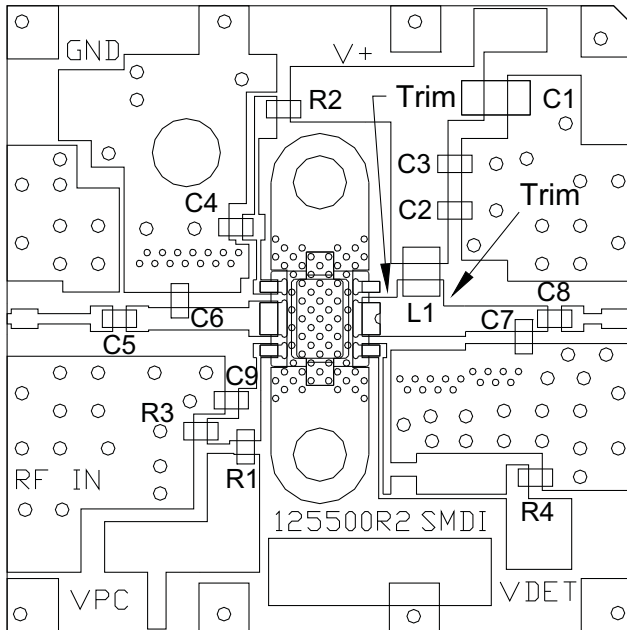

DESG	DESCRIPTION
Q1	SPB2026Z
R1	1.02K OHM, 0603 1%
R2	0 OHM, 0603
R3	4.02K OHM, 0603 1%
R4	47K OHM, 0603
C1	1uF Tant.
C2	15pF CAP, 0603 AVX
C3,C4,C9	0.1uF CAP, 0603
C5	15pF CAP, 0603 AVX
C6	3.9pF CAP, 0603 AVX
C7	3.3pF CAP, 0603 AVX
C8	15pF CAP, 0603 AVX
L1	27nH IND, CC 0805HQ

1930MHz to 1990MHz Application Schematic

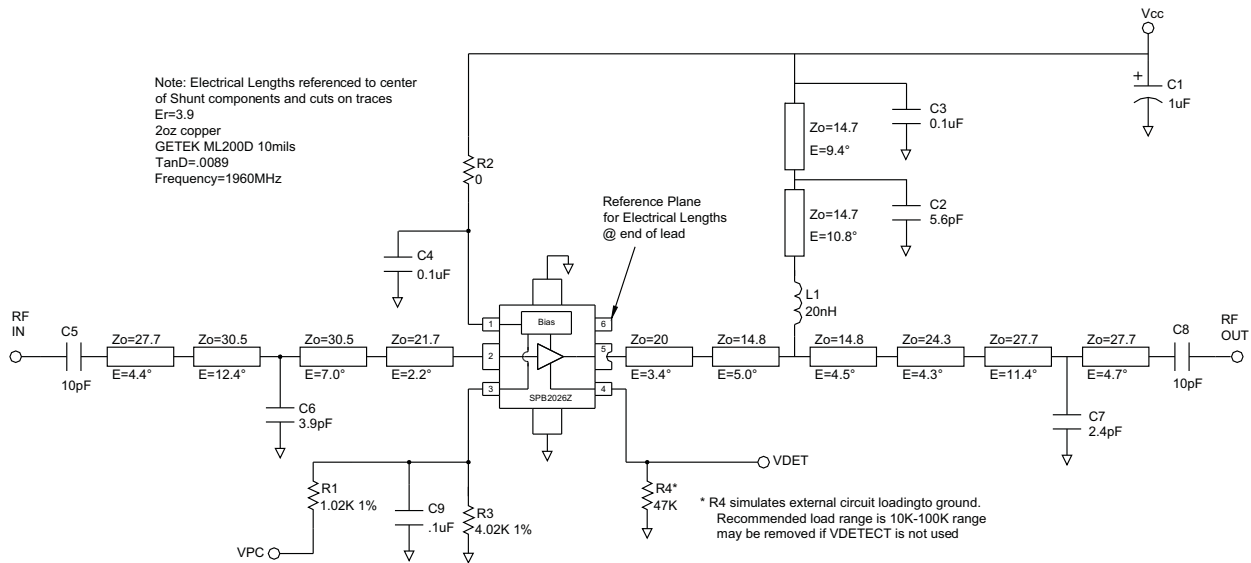

1930MHz to 1990MHz Evaluation Board Layout and Bill of Materials

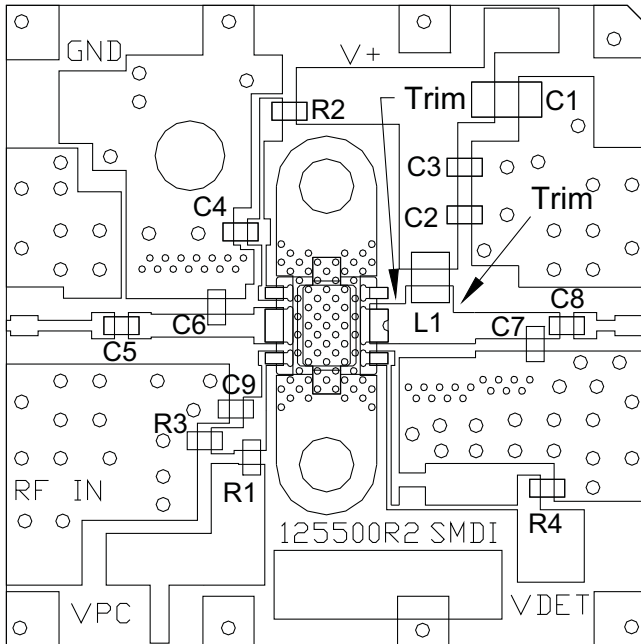

DESG	DESCRIPTION
Q1	SPB2026Z
R1	1.02K OHM, 0603 1%
R2	0 OHM, 0603
R3	4.02K OHM, 0603 1%
R4	47K OHM, 0603
C1	1uF Tant.
C2	5.6pF CAP, 0603 AVX
C3,C4,C9	0.1uF CAP, 0603
C5	10pF CAP, 0603 AVX
C6	3.9pF CAP, 0603 AVX
C7	2.4pF CAP, 0603 AVX
C8	10pF CAP, 0603 AVX
L1	20nH IND, CC 0805HQ

2110MHz to 2170MHz Application Schematic

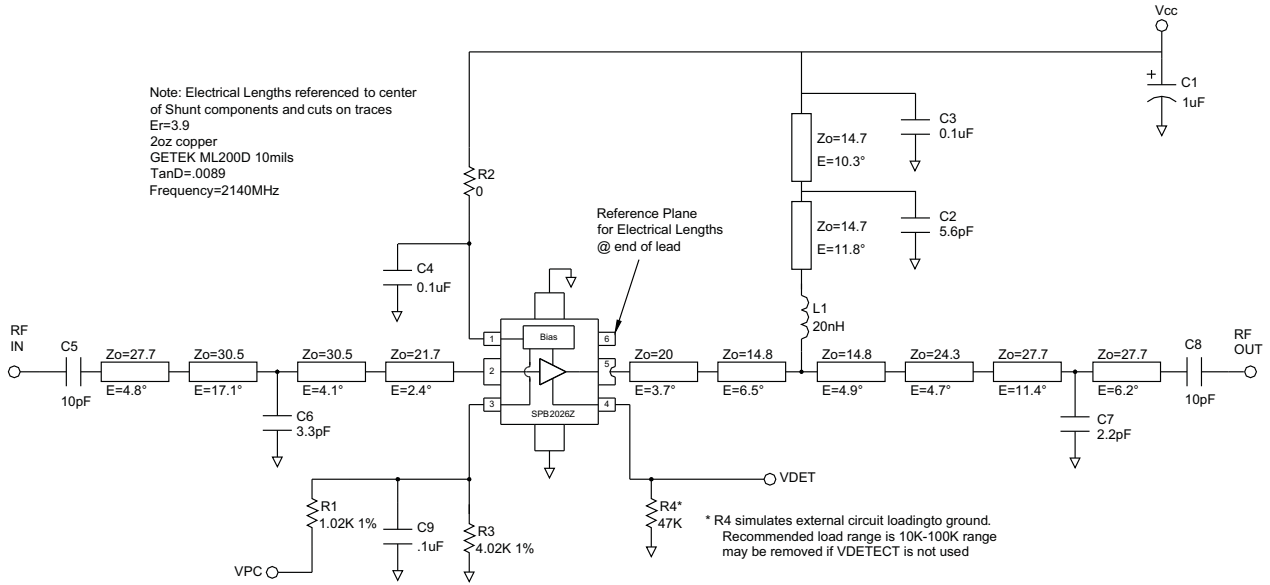

2110MHz to 2170MHz Evaluation Board Layout and Bill of Materials

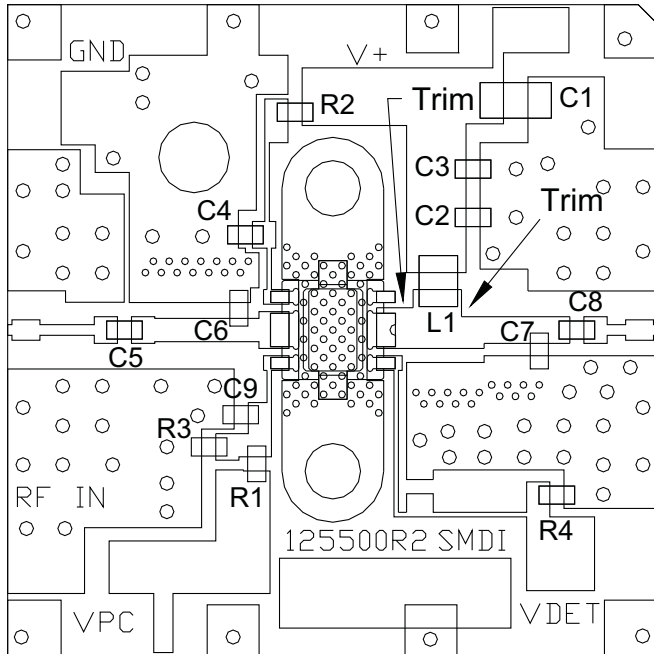

DESG	DESCRIPTION
Q1	SPB2026Z
R1	1.02K OHM, 0603 1%
R2	0 OHM, 0603
R3	4.02K OHM, 0603 1%
R4	47K OHM, 0603
C1	1uF Tant.
C2	5.6pF CAP, 0603 AVX
C3,C4,C9	0.1uF CAP, 0603
C5	10pF CAP, 0603 AVX
C6	3.3pF CAP, 0603 AVX
C7	2.2pF CAP, 0603 AVX
C8	10pF CAP, 0603 AVX
L1	20nH IND, CC 0805HQ

Part Identification

SPB2026Z on line one with Trace Code on line two.

Ordering Information

Part Number	Description
SPB2026Z	7" Reel with 1000 pieces
SPB2026ZSQ	Sample Bag with 25 pieces
SPB2026ZSR	7" Reel with 100 pieces
SPB2026ZPCK1	1805MHz to 1880MHz PCBA with 5 piece Sample Bag
SPB2026ZPCK2	1930MHz to 1990MHz PCBA with 5 piece Sample Bag
SPB2026ZPCK3	2110MHz to 2170MHz PCBA with 5 piece Sample Bag

NOT FOR NEW DESIGNS