

Highly integrated ballast controller for TL and CFL

**Features**

- Half bridge circuit able to drive both BJT and MOSFET transistors
- Very accurate oscillator precision in wide operating temperature range
- BJTs' storage time compensation
- Preheated start and instant start
- Hard switching protection
- Overcurrent / voltage protection
- Choke saturation control
- End-of-life protection
- Programmable without capacitors

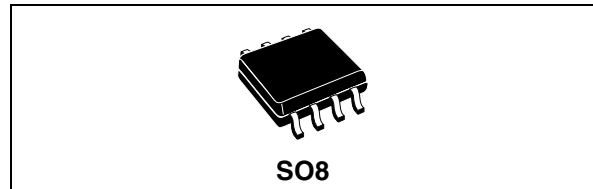

**Applications**

- Electronic ballasts (TL, Industrial CFL)
- Integrated CFLs

**Table 1. Device summary**

Order codes	Package	Packaging
L6520	SO8	Tube
L6520TR		Tape and reel
L6521		Tube
L6521TR		Tape and reel

**Figure 1. Block diagram**

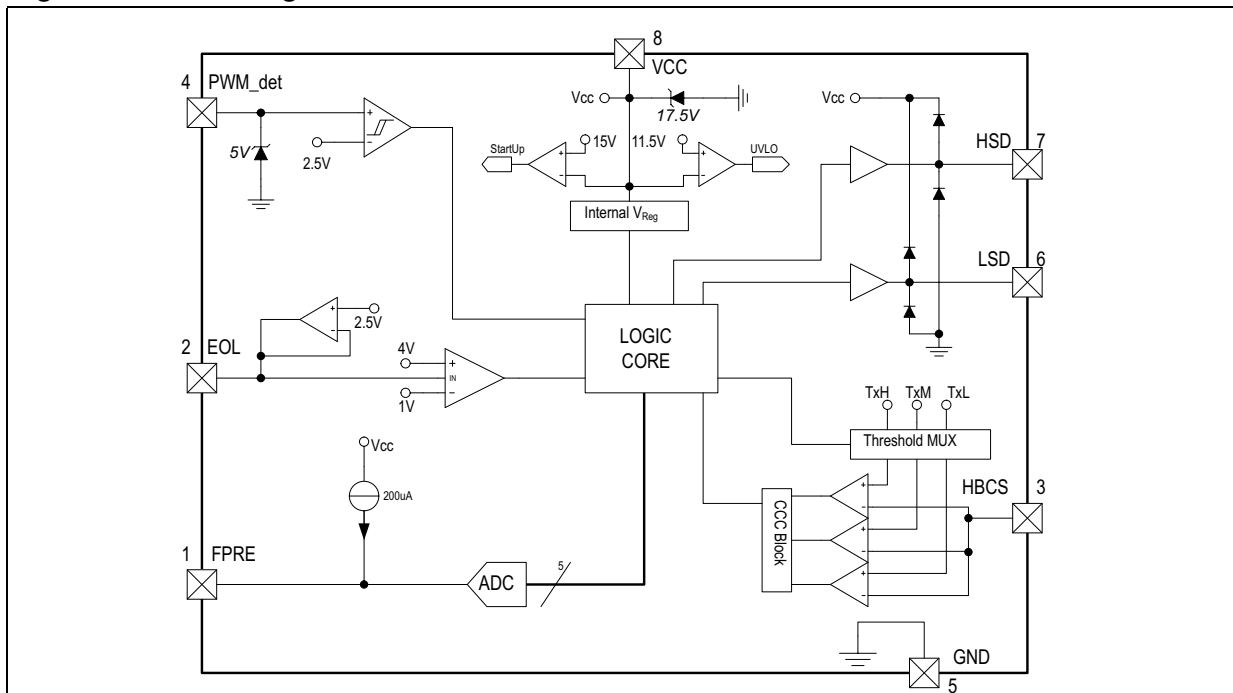

# Contents

<b>1</b>	<b>Description</b> .....	<b>3</b>
<b>2</b>	<b>Pin connection</b> .....	<b>4</b>
<b>3</b>	<b>Maximum ratings</b> .....	<b>5</b>
<b>4</b>	<b>Electrical characteristics</b> .....	<b>6</b>
<b>5</b>	<b>Functions description</b> .....	<b>9</b>
5.1	Start-up .....	9
5.2	Preheating and instant start .....	9
5.3	Ignition .....	10
5.4	Run mode .....	10
5.5	Storage time compensation network .....	10
5.6	Current control circuit (CCC) .....	11
5.6.1	Hard switching protection (HSP) .....	11
5.6.2	Overcurrent protection (OCPH) during ignition mode .....	11
5.6.3	Overcurrent protection (OCPL) during run mode .....	11
5.6.4	Choke saturation control (CSC) during ignition and run mode .....	12
5.7	End of life (EOL) .....	12
5.8	Summary of protections .....	13
<b>6</b>	<b>Typical electrical characteristics</b> .....	<b>14</b>
<b>7</b>	<b>Application examples</b> .....	<b>15</b>
<b>8</b>	<b>Package mechanical data</b> .....	<b>16</b>
<b>9</b>	<b>Revision history</b> .....	<b>18</b>

# 1 Description

The L6520/1 is the first highly integrated ballast controller in the market able to drive both BJTs and MOSFETs, providing all the necessary protections to ensure the maximum reliability of the application in compliance with major safety and power consumption regulations.

By adopting BJTs switches in the application, the IC allows to replace more expensive MOSFETs, strongly reducing the system cost without compromises.

The IC represents also the best and cost effective solution to replace self oscillating solutions when the key requirement is the reliability of the ballast. The benefits are an increased MTBF and a reduction of the costs due to the return from the field.

The higher level of flexibility and integration provided allows the possibility to quickly design ballast with any kind of lamp topology/size/power, without limitations. Depending on the power of the lamp, the IC can work without PFC, with passive PFC or with active PFC. In the latter case the L6562A from STMicroelectronics is the suggested IC for the most cost effective solution.

The IC is fully programmable using only resistors and offers over current protections, choke saturation control and hard switching protection thanks to a sophisticated current control circuit (CCC). In ignition, the CCC limits both the maximum lamp voltage in case of old or broken lamp, and also the lamp current in case of inductor saturation.

When the IC is driving bipolar transistors, a variable dead time ensures the correct base discharge time avoiding cross conduction phenomena. Moreover, the IC prevents the failure due to the lamp's end of life (EOL).

## 2 Pin connection

**Figure 2. Pin connection**

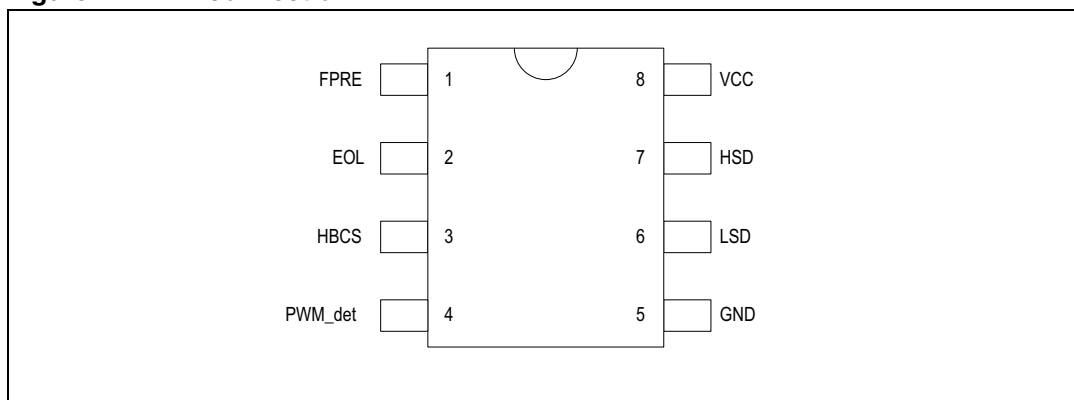

**Table 2. Pin description**

Symbol	Pin	Description
FPRE	1	Preheating frequency programming and ignition modes selection
EOL	2	Window comparator input
HBCS	3	Current sensing input
PWM_det	4	Half bridge middle point monitor
GND	5	IC power and signal ground
LSD	6	Low side driver output
HSD	7	High side driver output
VCC	8	Power supply

### 3 Maximum ratings

**Table 3. Absolute maximum ratings**

Symbol	Pin	Parameter	Conditions	Value	Unit
$V_Z$	8	Active clamp protection voltage	Active clamp protection must not be supplied by a low impedance voltage source	18.5	V
$I_{VCC}$	8	Active clamp protection current	During low consumption state	2	mA
$V_{OD1}$	6,7	Differential voltage between driver output and $V_{CC}$	$V_{OD1} = V_{CC} - V_{OUT}^{(1)}$	18.5	V
$V_{OD2}$	6,7	Differential voltage between driver output and GND	$V_{OD2} = V_{OUT} - GND^{(1)}$	18.5	V
$V_{FPRE}$	1	FPRE positive voltage		5	V
$V_{FPRE}$	1	FPRE negative voltage		-0.3	V
$V_{PWM\_det}$	4	PWM_det pin positive voltage	PWM_det input current < 5mA	5.1	V
$V_{PWM\_det}$	4	PWM_det pin negative voltage	PWM_det output current < 0.1mA	-0.3	V
$V_{HBCS}$	3	HBCS positive voltage		5	V
$V_{HBCS}$	3	HBCS negative voltage	HBCS output current < 2mA	-5	V
$V_{EOL,max}$	2	EOL positive voltage	EOL input current < 5mA	5	V
$V_{EOL,min}$	2	EOL negative voltage	EOL output current < 0.1mA	-0.3	V

1.  $V_{OUT}$  refers to the voltage at either LVG pin or HVG pin

**Table 4. Thermal data**

Symbol	Description	Value	Unit
$R_{thJA}$	Max. thermal resistance junction to ambient	150	°C/W
$T_J$	Junction operating temperature range	-40 to 150	°C
$T_{STG}$	Storage temperature	-55 to 150	°C

## 4 Electrical characteristics (a)

$V_{CC} = 16\text{ V}$ ,  $T_A = -25\text{ °C}$  to  $85\text{ °C}$ , unless otherwise specified

**Table 5. Electrical characteristics**

Symbol	Pin	Parameter	Test condition	Min.	Typ.	Max.	Unit
<b>Supply voltage</b>							
$V_{CC}$	VCC	Operating range	After turn-on <sup>(1)</sup>	10.5		$V_Z$	V
$V_{CC(ON)}$	VCC	Turn-on threshold		13.5	15	16.5	V
$V_{CC(OFF)}$	VCC	Turn-off threshold		10.5	11.5	12.5	V
$V_Z$	VCC	Zener voltage	$I_Z = 2\text{ mA}$	16.5	17.5	18.5	V
<b>Supply current</b>							
$I_{ST-UP}$	VCC	Start-up current	Before turn-on, ( $V_{CC} = 13\text{ V}$ )		130	200	$\mu\text{A}$
$I_{CC}$	VCC	Operating supply current	No load		8	10	mA
$I_Q$	VCC	Quiescent current	IDLE mode, <sup>(2)</sup>		150	220	$\mu\text{A}$
<b>Timing and oscillator</b>							
D		Output duty cycle	Run mode	49.5	50	50.5	%
$t_{DEAD}$		Fixed dead time	<sup>(3)</sup>	1.24	1.42	1.6	$\mu\text{s}$
$f_{RUN}$		HB run frequency	$T_{AMB} = 25\text{ °C}$	46	46.6	47.2	kHz
				43.2		47.8	kHz
$f_{PRE}$		Max programmable preheating frequency	$R_{FPRE} = 24.9\text{ k}\Omega$	96	100	104	kHz
$t_{PRE}$		Preheating time	$R_{FPRE} \geq 196\ \Omega$ , <sup>(1)</sup> , <sup>(4)</sup> , L6520		1.5		s
			$R_{FPRE} \geq 196\ \Omega$ , <sup>(2)</sup> , <sup>(4)</sup> , L6521		0.8		
$f_{INS}$		HB instant start initial frequency	FPRE connected to GND, <sup>(2)</sup>		85		kHz
$df_{IGN}/dt$		Ignition time frequency sweep rate	<sup>(4)</sup> , $T_{AMB} = 25\text{ °C}$		-2.75		kHz/ms
$df_{CCC}/dt$		Frequency sweep rate after overcurrent	<sup>(4)</sup> , $T_{AMB} = 25\text{ °C}$		-500		Hz/ms
$I_{FPRE}$	FPRE	FPRE current reference	$T_{AMB} = 25\text{ °C}$	200	202	204	$\mu\text{A}$
				192		204	
$t_{ON,min}$	HSD LSD	Minimum half bridge on time	$T_{AMB} = 25\text{ °C}$		1		$\mu\text{s}$
<b>Half bridge drivers</b>							
$V_{OL}$	HSD LSD	Output low voltage	$I_{load} = 300\text{ mA}$			3	V

a. This is a preliminary version: all the parameters are subject to change

Table 5. Electrical characteristics (continued)

Symbol	Pin	Parameter	Test condition	Min.	Typ.	Max.	Unit
V <sub>OH</sub>	HSD LSD	Output high voltage	I <sub>load</sub> = 300 mA	13			V
I <sub>SRC</sub>	HSD LSD	Peak source current		300			mA
I <sub>SNK</sub>	HSD LSD	Peak sink current		300			mA
T <sub>RISE</sub>	HSD LSD	Rise time	C <sub>load</sub> = 1 nF			120	ns
T <sub>FALL</sub>	HSD LSD	Fall time	C <sub>load</sub> = 1 nF			120	ns
I <sub>PD</sub>	HSD LSD	Pull down current	Before turn-on, (V <sub>CC</sub> = 13V) V <sub>LSD</sub> or V <sub>HSD</sub> = 1V	20			mA
<b>Storage time compensation and hard switching detection</b>							
V <sub>OUTup</sub>	PWM_det	PWM detector threshold	Positive going HB middle point	2.65		3	V
V <sub>HSW</sub>	PWM_det	Hard switching detector threshold	Negative going HB middle point	2		2.35	V
V <sub>P_dclamp</sub>	PWM_det	Clamping voltage	I <sub>PWM_det</sub> = 2 mA	4.5	5	5.5	V
t <sub>HSW</sub>	PWM_det	Max. time of hard switching operation	(4), T <sub>AMB</sub> = 25 °C		200		ms
<b>Half bridge current control circuit (CCC)</b>							
THL	HBCS	First threshold in ignition mode		0.96	1	1.04	V
THM	HBCS	Second threshold in ignition mode		1.21	1.26	1.31	V
THH	HBCS	Third threshold in ignition mode		2.4	2.5	2.6	V
TLL	HBCS	First threshold in run mode		0.67	0.7	0.73	V
TLM	HBCS	Second threshold in run mode		0.87	0.9	0.93	V
TLH	HBCS	Third threshold in run mode		1.7	1.8	1.9	V
T <sub>PROT</sub>		Maximum current control time	(4), T <sub>AMB</sub> = 25 °C		200		ms
t1	HBCS	Minimum interval between two consecutive threshold crossing for slow events	(4), T <sub>AMB</sub> = 25 °C		510		ns
t2	HBCS	Minimum interval between two consecutive threshold crossing for fast events (not saturating)	(4), T <sub>AMB</sub> = 25 °C		255		ns
Δf <sub>TxL</sub>	HBCS	Frequency increase in case of lower threshold crossing	(4), T <sub>AMB</sub> = 25 °C		1		kHz
Δf <sub>slow</sub>	HBCS	Frequency increase in case of slow event	(4), T <sub>AMB</sub> = 25 °C		1		kHz
Δf <sub>fast</sub>	HBCS	Frequency increase in case of fast event	(4), T <sub>AMB</sub> = 25 °C		2		kHz

**Table 5. Electrical characteristics (continued)**

Symbol	Pin	Parameter	Test condition	Min.	Typ.	Max.	Unit
$t_{LEB}$	HBCS	Leading edge time after LSD turn on	<sup>(4)</sup> , $T_{AMB} = 25\text{ °C}$		255		ns
<b>End of life</b>							
$V_{EOL}$	EOL	EOL pin biasing voltage reference		2.43	2.5	2.57	V
$V_{EOL\_H}$	EOL	EOL upper threshold		3.84	4	4.16	V
$V_{EOL\_L}$	EOL	EOL lower threshold		0.96	1	1.04	V
$I_{EOL}$	EOL	Sink/source capability	$V_{EOL} = 1.5V$ (source) $V_{EOL} = 3.5V$ (sink)	8.2	9.1	10	$\mu A$
$t_{EOL}$	EOL	Protection delay time	<sup>(4)</sup> , $T_{AMB} = 25\text{ °C}$		1.5		s

1. During the operation at  $V_{CC} \geq V_Z$  the maximum supply current must be limited to 2mA.
2. Guaranteed by characterization.
3.  $t_{DEAD}$  is the sum of a fixed time, generated by internal logic and the propagation delay of PWM\_det comparator.
4. Guaranteed by testing logic verification.



## 5 Functions description

### 5.1 Start-up

During the first start-up ramp of the supply voltage ( $V_{CC}$ ) both driver outputs, LSD and HSD, are low impedance to ground ( $I_{sink} 20 \text{ mA min}$ ). Once the  $V_{CC}$  voltage reaches the turn-on voltage  $V_{CC(ON)}$  the IC starts its operation. During the first  $100 \mu\text{s}$  the IC senses the status of FPRE pin to detect the programmed preheating frequency and the selected ignition mode (instant or preheated start). When all the IC internal functions are ready, the driver-outputs are released.

If the preheated start is selected, the half-bridge oscillates at the programmed preheating frequency, otherwise it starts from 85 kHz (typ.).

### 5.2 Preheating and instant start

The preheating time is 1.5 s (typ.) in the L6520 and 0.8 s (typ.) in the L6521. The FPRE pin embeds a precise current reference: the voltage read by this pin sets the preheating frequency or enables the instant start. If the FPRE pin is connected to ground, the instant start is active and the IC runs immediately into ignition sequence from the starting frequency of 85 kHz. If the pin FPRE is connected to a resistor equal or higher than  $196 \Omega$  the preheating frequency can be programmed from 55 kHz upwards till 100 kHz (1.5 kHz/step) accordingly to [Table 6](#). For the best precision the resistor tolerance should be less or equal to 1%. After the preheating sequence, the IC runs into ignition mode.

**Table 6. Preheating and instant start**

$F_{PRE}$ (kHz)	$R_{FPRE}$ ( $\Omega$ )	$F_{PRE}$ (kHz)	$R_{FPRE}$ ( $\Omega$ )
Instant start	0	77.5	5490
55	196	79	6190
56.5	383	80.5	6980
58	576	82	7870
59.5	806	83.5	8660
61	1050	85	9530
62.5	1300	86.5	10500
64.	1580	88	11500
65.5	1870	89.5	12700
67	2210	91	14000
68.5	2550	92.5	15400
70	2940	94	16900
71.5	3400	95.5	18700
73	3830	97	20500
74.5	4320	98.5	22600
76	4870	100	24900

### 5.3 Ignition

During the ignition sequence the output frequency ramps down from the programmed preheating frequency to the fixed run frequency with a fixed rate  $df_{IGN}/dt$  of - 2.75 kHz/ms. If the instant start is selected, the frequency ramps down from 85 kHz to 46.6 kHz (typ.) with the same rate.

The current control circuit limits the maximum lamp voltage (OCPH) in case of old or broken lamp and it is able to control the lamp current in case of inductor saturation (CSC).

The ignition phase lasts for maximum 200 ms. If the Run frequency is not reached during ignition phase, the IC is turned off (latched).

### 5.4 Run mode

The run frequency is internally set to 46.6 kHz.

The HSD and LSD pins drive respectively the high side and the low side switches. The potential isolation to the high side switch is realized by a pulse transformer. The HSD and LSD drivers are able to manage the inductive load represented by the primary side of the pulse transformer.

Between the turn-off of one driver and turn-on of the other one there is a dead time automatically optimized accordingly to the kind of the half bridge switches (MOS or BJT) to ensure the maximum reliability. The CCC protects the circuit against over currents, choke saturation and hard switching events.

### 5.5 Storage time compensation network

In all the operating states (preheating, ignition and run mode), the storage time compensation ensures the application of the fixed dead time ( $t_{DEAD}$ : 1.42  $\mu$ s typ.) once the BJT's collector current is effectively reduced to zero. The  $t_{DEAD}$  is the sum of a fixed time, generated by internal logic and the propagation delay of PWM\_det comparator.

The voltage level of the middle point of the half bridge is monitored through the PWM\_det pin: the high side switch is turned on after a fixed dead time from the instant when the voltage on the PWM\_det pin is above 2.65 V. The time between the falling edge of pin LSD and the rising edge of HSD is recorded in order to set the same dead time between the falling edge of pin HSD and the rising edge of pin LSD.

The minimum duration of the resulting ON time is internally limited to 1  $\mu$ s. This condition can last for a maximum time equal to 200 ms. After this time the IC is shut down (latched).

The PWM\_det pin embeds a 5 V (typ.) clamping zener, allowing the connection between the half bridge middle point and the pin itself by means of a limiting resistor.

When driving MOSFET no storage time is present, therefore the resulting dead time is equal to (1.42  $\mu$ s).

## 5.6 Current control circuit (CCC)

The current control circuit (CCC) is a sophisticated circuit able to protect the ballast against any possible failure. It limits the maximum lamp voltage during ignition (OCPH), overcurrent protection (OCPL) during run mode, chokes saturation control (CSC) and hard switching protection (HSP). The control circuit senses the voltage on HBCS pin and PWM\_det pin.

*Figure 3 on page 13* shows the CCC protections active in each operating mode (preheating, ignition and run):

### 5.6.1 Hard switching protection (HSP)

If the voltage on PWM\_det pin is higher than 2.35 V at the moment the LS driver turns on, an up-down event counter is increased and an internal timer is started. Without hard switching events, the counter decreases at every cycle and the timer is reset when 0 is reached. If the events counter value is higher than 0 after 200 ms from the detection of the first event, then the IC is turned off (latched).

### 5.6.2 Overcurrent protection (OCPH) during ignition mode

The protection results in lamp voltage limitation during ignition. In this phase three thresholds are active (THL, THM and THH):

If the first threshold is crossed the frequency is increased by 1 kHz during the next cycle.

The interval between the crossings of the two lower thresholds (THL and THM) is used as an indication of the slope of the half bridge current: if this interval is longer than  $t_1 = 510$  ns the event is considered "slow" and the frequency is increased by another 1 kHz/cycle during the next cycle. If the interval is shorter than  $t_1 = 510$  ns but longer than  $t_2 = 255$  ns, the event is considered "fast" and the frequency is increased by another 2 kHz/cycle during the next cycle.

If no further threshold crossing is detected, the frequency is decreased with a fixed rate equal to  $df_{CCC}/dt = -500$  Hz/ms, until the frequency at which the lowest threshold was crossed firstly is reached; then, the decreasing ratio becomes again  $df_{IGN}/dt$ .

If the run frequency has not been reached within 200 ms after the lower threshold was crossed the first time, the IC is turned off (latched).

A leading edge blanking of 255 ns is active.

### 5.6.3 Overcurrent protection (OCPL) during run mode

The behavior of the OCPL is similar to the OCPH but with reduced thresholds (TLL, TLM and TLH) since the current involved in this phase is smaller. If no further threshold crossing is detected, the frequency is decreased with a fixed rate equal to  $df_{CCC}/dt = -500$  Hz/ms, until the run frequency is reached.

If the run frequency has not been reached after 200 ms from when the lower threshold was crossed the first time, the IC is turned off (latched).

A leading edge blanking of 255 ns is active.

#### 5.6.4 Choke saturation control (CSC) during ignition and run mode

The same thresholds used to detect OCPH and OCPL are active.

The control is still based on the time between two consecutive thresholds but its behavior is different with respect to the OCPH/OCPL detection to take into account the increase of  $di/dt$  when the inductor is saturating. When either the two lower thresholds are crossed in a time shorter than 255 ns or the higher threshold is crossed, the LS driver is immediately turned off and the time between the LS turn on and the instant when the second threshold (THM or TLM) is crossed is used to calculate the new (higher) frequency.

If this new frequency is higher than 100 kHz then the new frequency will be set at 100 kHz.

The frequency is then decreased with a fixed  $df/dt$  equal to  $df_{CCC}/dt = -500 \text{ Hz/ms}$ , until the frequency at which the first threshold was crossed is reached. Then, the decreasing ratio becomes again  $df_{IGN}/dt$  during ignition whereas, during run mode, the  $df_{CCC}/dt$  decreasing ratio is maintained until run frequency is reached.

If the run frequency has not been reached after 200 ms from when the lower threshold was crossed the first time, the IC is turned off (latched).

A leading edge blanking of 255 ns is active.

#### 5.7 End of life (EOL)

An embedded window comparator can be used to detect the end of life (EOL) when the lamp is directly connected to ground (lamp to ground configuration).

After the ignition sequence, the EOL window comparator becomes active. When the voltage at EOL pin goes outside the limits of this comparator a 1.5 s timer is started. If the EOL pin voltage does not return inside the allowed range before the end of the timer, the IC is shut down (latched).

The EOL pin is biased to the center of the window comparator by means of an OTA (2.5 V typ. with +/- 1.5 V typ. window), having a current capability equal to 9.1  $\mu\text{A}$  (typ.).

### 5.8 Summary of protections

Figure 3. Summary of protections

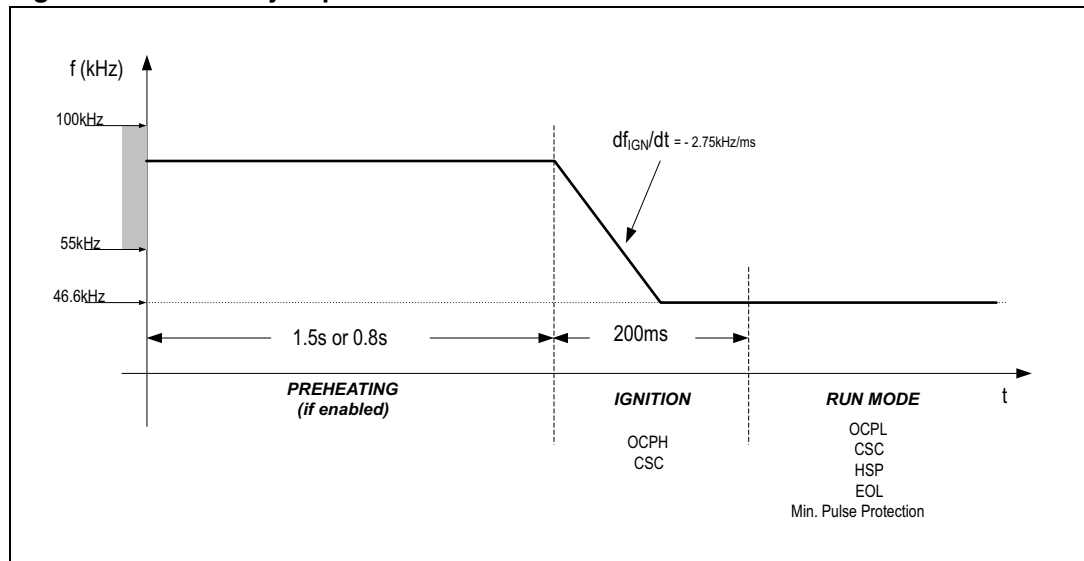

Table 7. Table of faults

Fault	Active during			Condition	Ic behaviour	Required action
	PH	Ign	Run			
Minimum driving pulse duration			✓	Driving pulses shorter than 1 $\mu$ s	- The drivers are stopped after 200 ms of minimum pulse duration events - The IC is shut down in low consumption mode	V <sub>CC</sub> cycle
Inductor saturation		✓	✓	HBCS TxL and TxM thresholds crossed in less than 255 ns OR Higher threshold crossing	LS driver turned off and a new frequency is calculated. If the situation is not recovered after 200 ms, the IC is shut down in low consumption mode	V <sub>CC</sub> cycle
Hard switching			✓	PWM_det higher than 2.35 V at LSD turn on	IC is shut down in low consumption mode after 200 ms of HSW events	V <sub>CC</sub> cycle
Overcurrent		✓	✓	HBCS TxL and TxM thresholds crossing (different values during ignition or run mode)	Frequency increase proportional to the failure. If the situation is not recovered after 200 ms the IC is shut down in low consumption mode	V <sub>CC</sub> cycle
End Of Life			✓	EOL voltage outside the limits of the window comparator	- Delay time started - If EOL voltage is outside the limits of the window comparator at the end of the timer count than the IC is shut down (latched)	V <sub>CC</sub> cycle

## 6 Typical electrical characteristics

Figure 4. VCC thresholds vs temperature

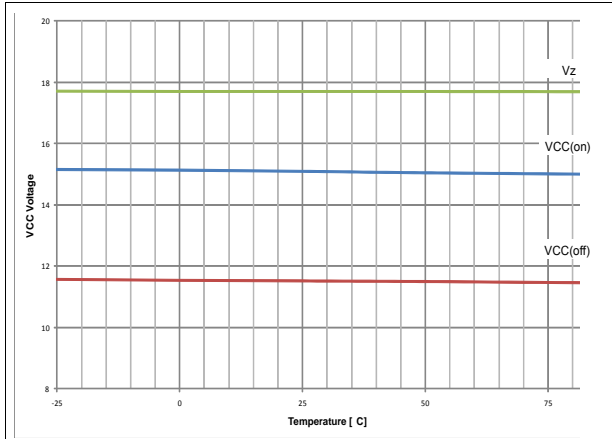

Figure 5. Frequencies vs temperature

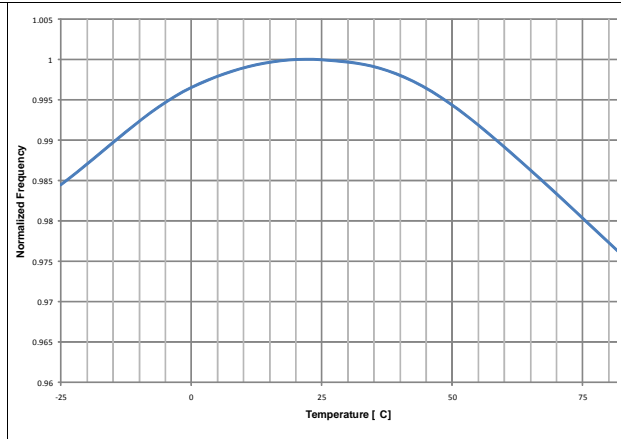

Figure 6. Times vs temperature

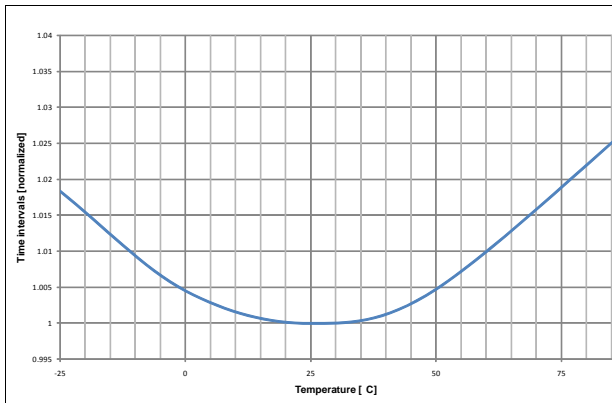

Figure 7. FPRE resistance converter temperature behavior

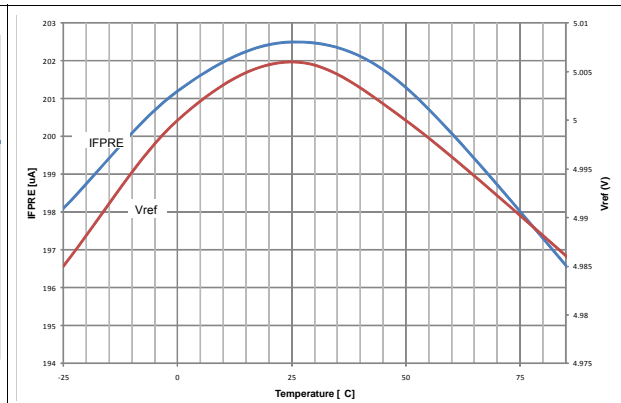

Figure 8. IEOL vs temperature

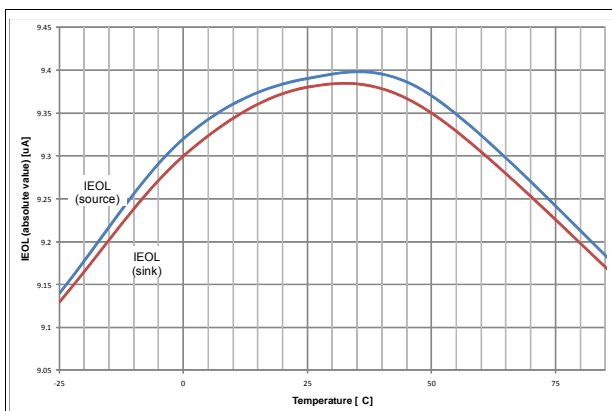
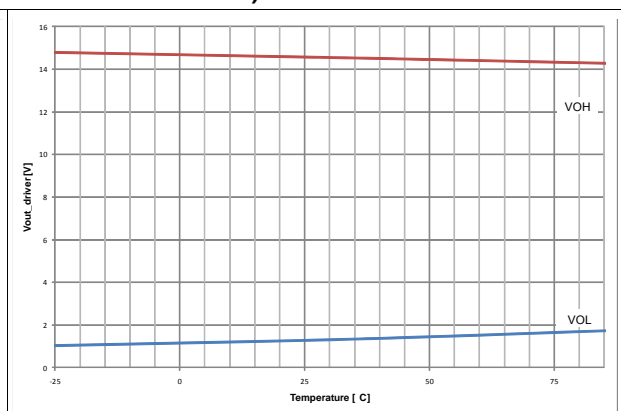

Figure 9. LSG and HSG output voltage vs temperature (driver's current: 300mA)



# 7 Application examples

Figure 10. BJT application example

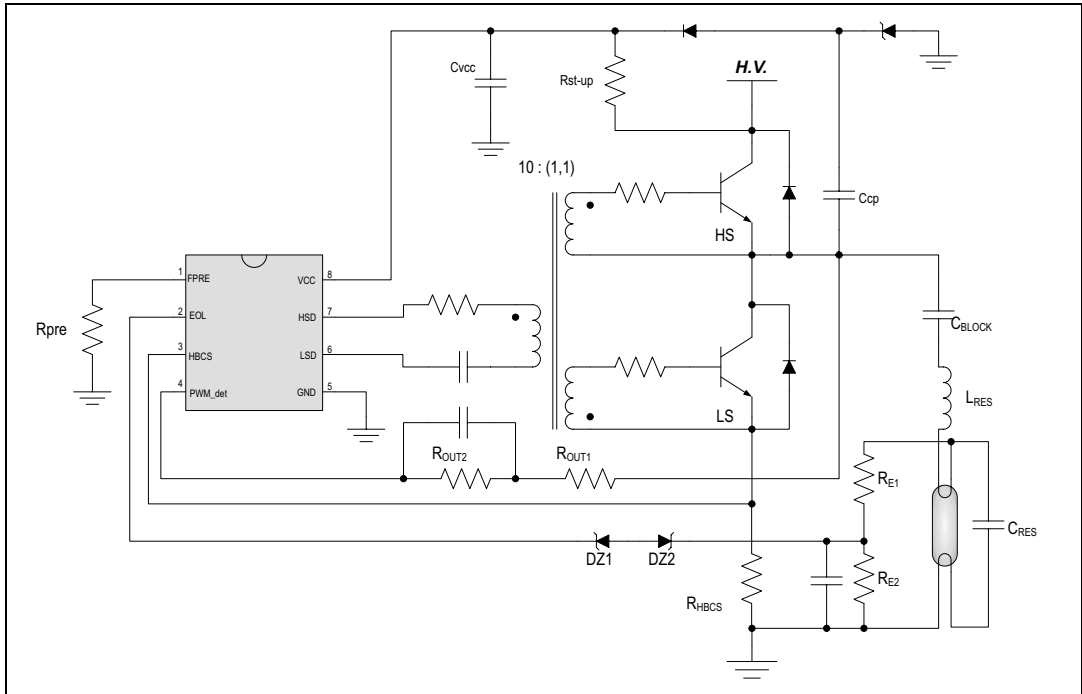
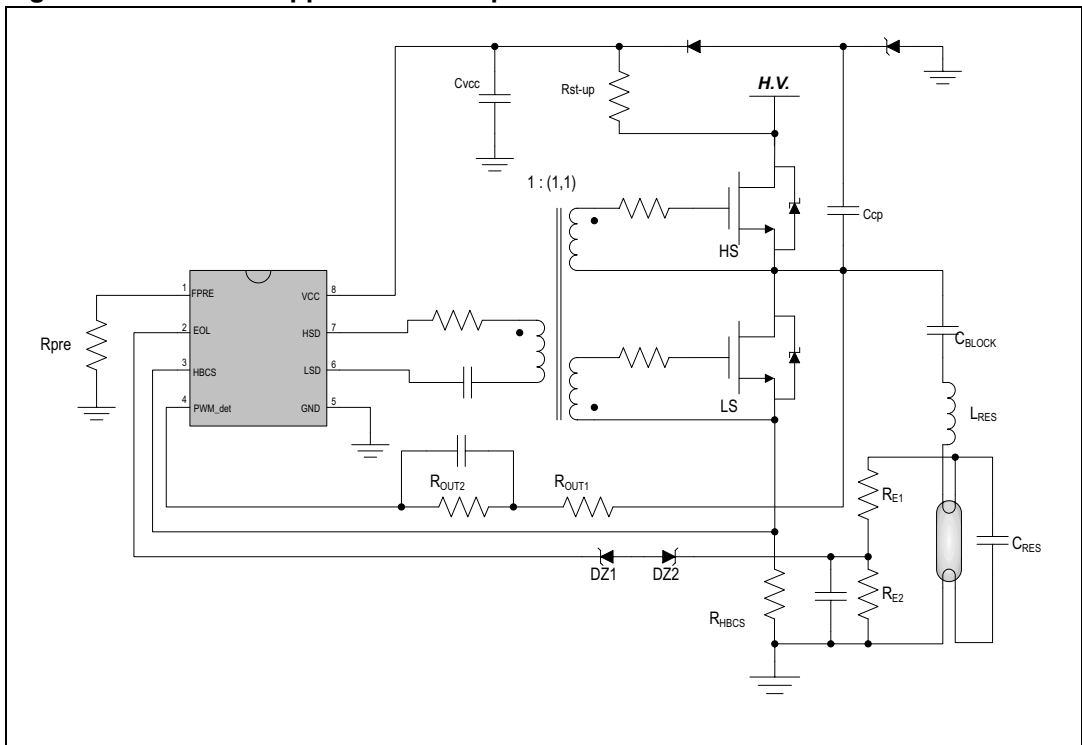

Figure 11. MOSFET application example



## 8 Package mechanical data

In order to meet environmental requirements, ST offers these devices in different grades of ECOPACK<sup>®</sup> packages, depending on their level of environmental compliance. ECOPACK<sup>®</sup> specifications, grade definitions and product status are available at: [www.st.com](http://www.st.com). ECOPACK is an ST trademark.

**Table 8. SO-8 mechanical data**

Dim.	mm.			inch		
	Min	Typ	Max	Min	Typ	Max
A	1.35		1.75	0.053		0.069
A1	0.10		0.25	0.004		0.010
A2	1.10		1.65	0.043		0.065
B	0.33		0.51	0.013		0.020
C	0.19		0.25	0.007		0.010
D <sup>(1)</sup>	4.80		5.00	0.189		0.197
E	3.80		4.00	0.15		0.157
e		1.27			0.050	
H	5.80		6.20	0.228		0.244
h	0.25		0.50	0.010		0.020
L	0.40		1.27	0.016		0.050
k	0° (min.), 8° (max.)					
ddd			0.10			0.004

1. Dimensions D does not include mold flash, protrusions or gate burrs. Mold flash, protrusions or gate burrs shall not exceed 0.15mm (.006inch) in total (both side).



Figure 12. Package dimensions

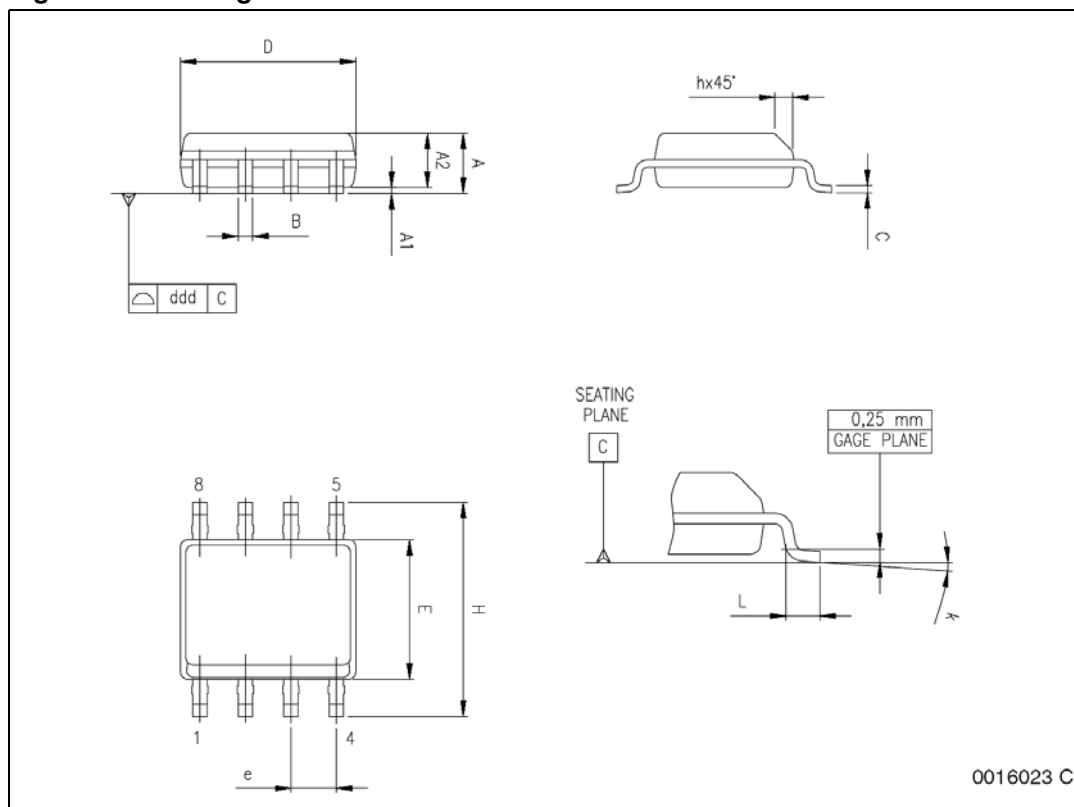

## 9 Revision history

**Table 9. Document revision history**

Date	Revision	Changes
19-Jan-2010	1	Initial release
08-Feb-2011	2	Added: L6521 option, <a href="#">Section 6: Typical electrical characteristics</a> Updated: Coverpage, <a href="#">Figure 1</a> , <a href="#">Table 4</a> , <a href="#">Table 5</a> , <a href="#">Section 1</a> , <a href="#">Figure 3</a> , <a href="#">Table 7</a> , <a href="#">Figure 10</a> , <a href="#">Figure 11</a>
09-Mar-2011	3	Datasheet updated from preliminary data to final datasheet

**Please Read Carefully:**

Information in this document is provided solely in connection with ST products. STMicroelectronics NV and its subsidiaries ("ST") reserve the right to make changes, corrections, modifications or improvements, to this document, and the products and services described herein at any time, without notice.

All ST products are sold pursuant to ST's terms and conditions of sale.

Purchasers are solely responsible for the choice, selection and use of the ST products and services described herein, and ST assumes no liability whatsoever relating to the choice, selection or use of the ST products and services described herein.

No license, express or implied, by estoppel or otherwise, to any intellectual property rights is granted under this document. If any part of this document refers to any third party products or services it shall not be deemed a license grant by ST for the use of such third party products or services, or any intellectual property contained therein or considered as a warranty covering the use in any manner whatsoever of such third party products or services or any intellectual property contained therein.

**UNLESS OTHERWISE SET FORTH IN ST'S TERMS AND CONDITIONS OF SALE ST DISCLAIMS ANY EXPRESS OR IMPLIED WARRANTY WITH RESPECT TO THE USE AND/OR SALE OF ST PRODUCTS INCLUDING WITHOUT LIMITATION IMPLIED WARRANTIES OF MERCHANTABILITY, FITNESS FOR A PARTICULAR PURPOSE (AND THEIR EQUIVALENTS UNDER THE LAWS OF ANY JURISDICTION), OR INFRINGEMENT OF ANY PATENT, COPYRIGHT OR OTHER INTELLECTUAL PROPERTY RIGHT.**

**UNLESS EXPRESSLY APPROVED IN WRITING BY AN AUTHORIZED ST REPRESENTATIVE, ST PRODUCTS ARE NOT RECOMMENDED, AUTHORIZED OR WARRANTED FOR USE IN MILITARY, AIR CRAFT, SPACE, LIFE SAVING, OR LIFE SUSTAINING APPLICATIONS, NOR IN PRODUCTS OR SYSTEMS WHERE FAILURE OR MALFUNCTION MAY RESULT IN PERSONAL INJURY, DEATH, OR SEVERE PROPERTY OR ENVIRONMENTAL DAMAGE. ST PRODUCTS WHICH ARE NOT SPECIFIED AS "AUTOMOTIVE GRADE" MAY ONLY BE USED IN AUTOMOTIVE APPLICATIONS AT USER'S OWN RISK.**

Resale of ST products with provisions different from the statements and/or technical features set forth in this document shall immediately void any warranty granted by ST for the ST product or service described herein and shall not create or extend in any manner whatsoever, any liability of ST.

ST and the ST logo are trademarks or registered trademarks of ST in various countries.

Information in this document supersedes and replaces all information previously supplied.

The ST logo is a registered trademark of STMicroelectronics. All other names are the property of their respective owners.

© 2011 STMicroelectronics - All rights reserved

STMicroelectronics group of companies

Australia - Belgium - Brazil - Canada - China - Czech Republic - Finland - France - Germany - Hong Kong - India - Israel - Italy - Japan - Malaysia - Malta - Morocco - Philippines - Singapore - Spain - Sweden - Switzerland - United Kingdom - United States of America

[www.st.com](http://www.st.com)

