



LM134-LM234-LM334

Three terminal adjustable current sources

Features

- Operates from 1V to 40V
- 0.02%/V current regulation
- Programmable from 1 μ A to 10mA
- \pm 3% initial accuracy

Description

The LM134/LM234/LM334 are 3-terminal adjustable current sources characterized by:

- an operating current range of 10000: 1
- an excellent current regulation
- a wide dynamic voltage range of 1V t 10V

The current is determined by an external resistor without requiring other external components.

Reverse voltages of up to 20V will only draw a current of several microamperes. This enables the circuit to operate as a rectifier and as a source of current in a.c. applications.

For the LM134/LM234/LM334, the voltage on the control pin is 64mV at +25°C and is directly proportional to the absolute temperature ($^{\circ}$ K). The simplest external resistor connection generates a current with approximately 0.33%/ $^{\circ}$ C temperature dependence. Zero drift can be obtained by adding an additional resistor and a diode to the external circuit.



Z
TO-92
(Plastic package)



D
SO-8
(Plastic micropackage)

Pin connections

TO-92
(Bottom view)

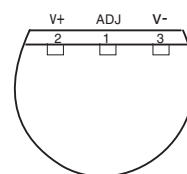

SO-8
(Top view)

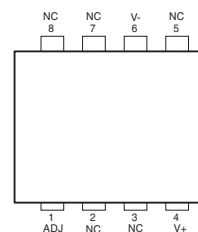

1 Schematic diagram

Figure 1. Schematic diagram

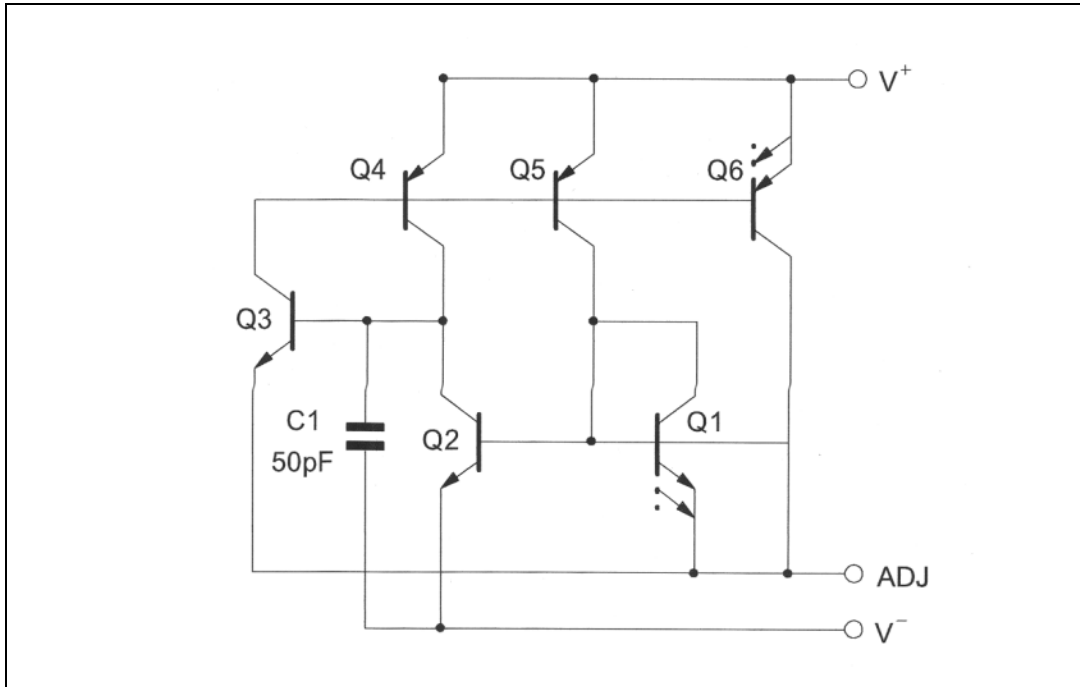

2 Absolute maximum ratings

Table 1. Absolute maximum ratings

Symbol	Parameter	LM134	LM234	LM334	Unit
	Voltage V+ to V- Forward Reverse	40 20		30 20	V
V_{ADJ^-}	ADJ pin to V- voltage	5			V
I_{set}	Set current	10			mA
P_{tot}	Power dissipation	400			mW
T_{stg}	Storage temperature range	-65 to +150			°C
T_{oper}	Operating free-air temperature range	-55 to +125	-25 to +100	0 to +70	°C

3 Electrical characteristics

$T_j = +25^\circ\text{C}$ with pulse testing so that junction temperature does not change during testing (unless otherwise specified)

Table 2. Electrical characteristics

Parameter	LM134 - LM234			LM334			Unit
	Min.	Typ.	Max.	Min.	Typ.	Max.	
Set current error ($V^+ = +2.5\text{V}$) ⁻⁽¹⁾ $10\mu\text{A} \leq I_{\text{set}} \leq 1\text{mA}$ $1\text{mA} \leq I_{\text{set}} \leq 5\text{mA}$ $2\mu\text{A} \leq I_{\text{set}} \leq 10\mu\text{A}$			3 5 8			6 8 12	%
Ratio of set current to V_- current $10\mu\text{A} \leq I_{\text{set}} \leq 1\text{mA}$ $1\text{mA} \leq I_{\text{set}} \leq 5\text{mA}$ $2\mu\text{A} \leq I_{\text{set}} \leq 10\mu\text{A}$	14	18 14 14	23	14	18 14 14	26	
Minimum operating voltage $2\mu\text{A} \leq I_{\text{set}} \leq 100\mu\text{A}$ $100\mu\text{A} \leq I_{\text{set}} \leq 1\text{mA}$ $1\text{mA} \leq I_{\text{set}} \leq 5\text{mA}$		0.8 0.9 1			0.8 0.9 1		V
Average change in set current with input voltage $2\mu\text{A} \leq I_{\text{set}} \leq 1\text{mA}$ $+1.5\text{V} \leq V^+ \leq +5\text{V}$ $+5\text{V} \leq V^+ \leq +40\text{V}$ $1\text{mA} \leq I_{\text{set}} \leq 5\text{mA}$ $+1.5\text{V} \leq V^+ \leq +5\text{V}$ $+5\text{V} \leq V^+ \leq +40\text{V}$		0.02 0.01	0.05 0.03		0.02 0.01	0.1 0.05	% / V
Temperature dependence of set current ⁻⁽²⁾ $25\mu\text{A} \leq I_{\text{set}} \leq 1\text{mA}$	0.96 T	T	1.04 T	0.96 T	T	1.04 T	
Effective shunt capacitance		15			15		pF

1. The set current is the current flowing into the V_+ pin. It is determined by the following formula:

$$I_{\text{set}} = 67.7\text{mV}/R_{\text{set}} \quad (T_j = +25^\circ\text{C})$$

The set current error is expressed as a percent deviation from this amount.

2. I_{set} is directly proportional to absolute temperature ($^\circ\text{K}$). I_{set} at any temperature can be calculated from

$$I_{\text{set}} = I_0 (T/T_0)$$

where I_0 is I_{set} measured at T_0 ($^\circ\text{K}$).

Figure 2. Output impedance

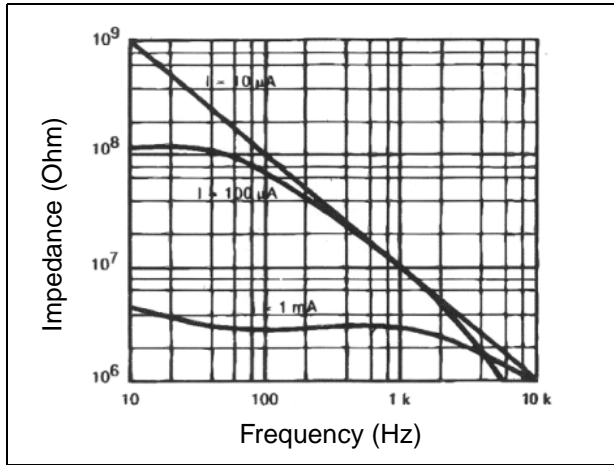

Figure 3. Maximum slew rate for linear operation

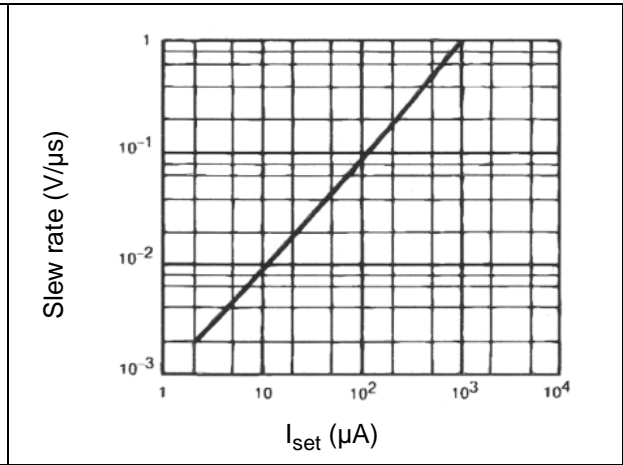

Figure 4. Startup

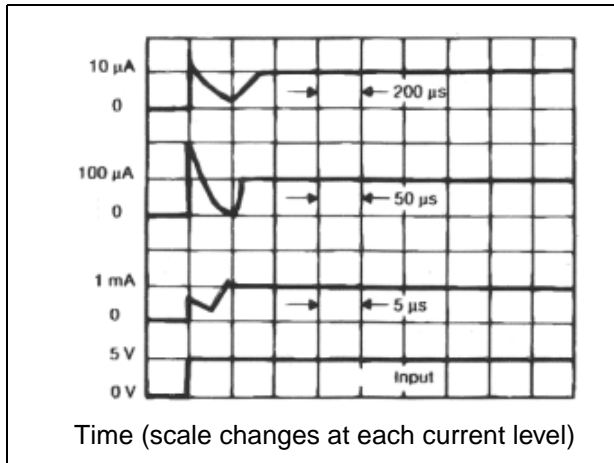

Figure 5. Transient response

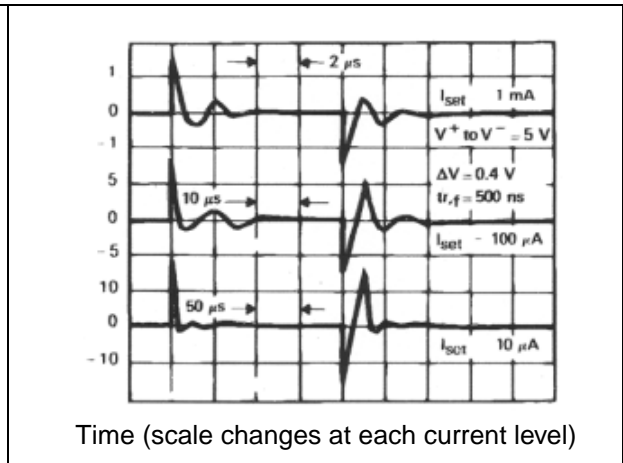

Figure 6. Voltage across R_{set}

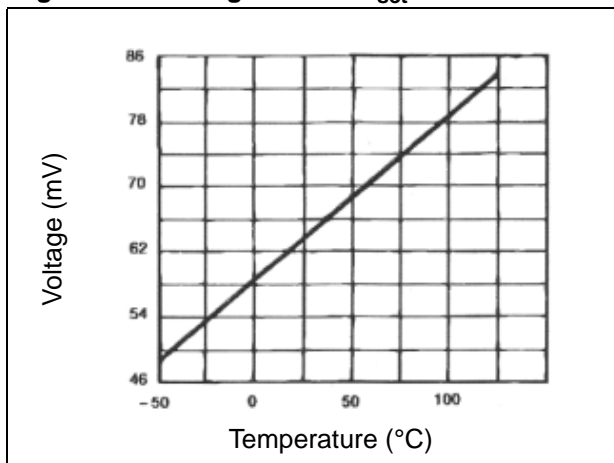

Figure 7. Current noise

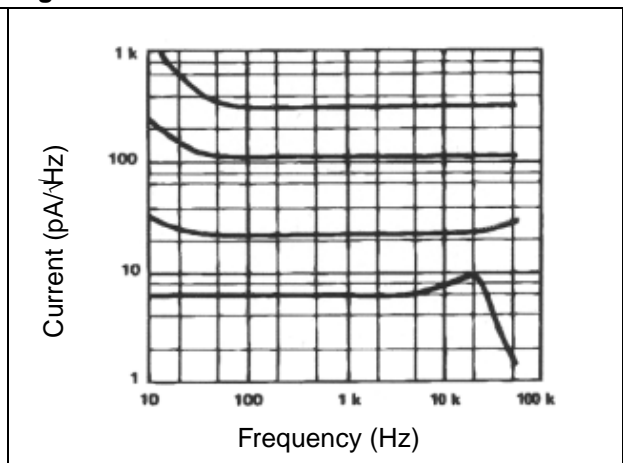

Figure 8. Turn-on voltage

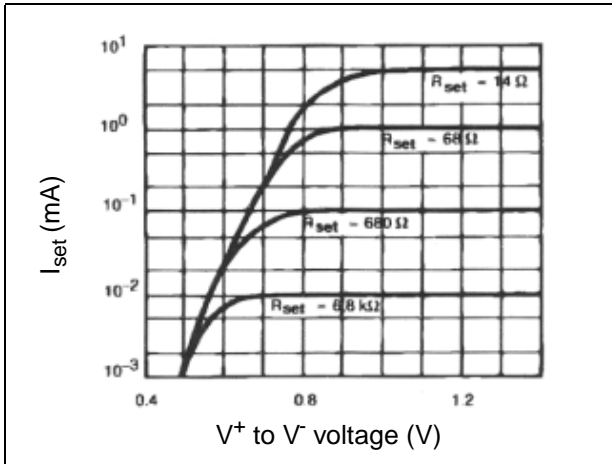
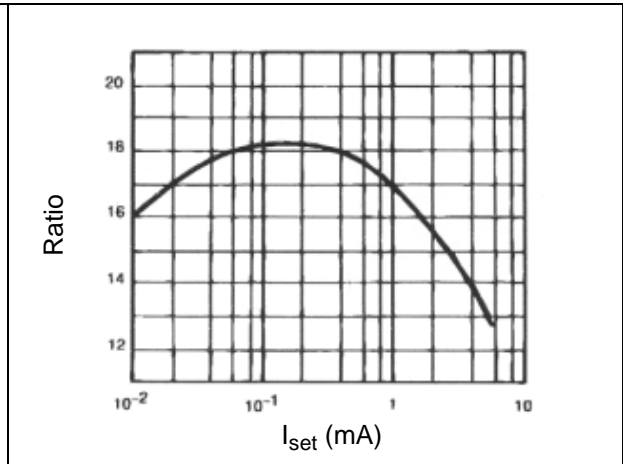

Figure 9. Ratio of I_{set} to V^- current



4 Application information

4.1 Slew rate

At slew rates above a threshold (see [Figure 4](#) and [Figure 5](#)), the LM134, LM234, LM334 can have a non-linear current characteristic. The slew rate at which this takes place is directly proportional to I_{set} . At $I_{\text{set}} = 10\mu\text{A}$, $dv/dt \text{ max.} = 0.01\text{V}/\mu\text{s}$; at $I_{\text{set}} = 1\text{mA}$, $dv/dt \text{ max.} = 1\text{V}/\mu\text{s}$. Slew rates of more than $1\text{V}/\mu\text{s}$ do not damage the circuit nor do they produce high currents.

4.2 Thermal effects

Internal heating can have a significant effect on current regulation for an I_{set} above $100\mu\text{A}$. For example, each increase of 1V in the voltage across the LM134 at $I_{\text{set}} = 1\text{mA}$ will increase the junction temperature by $\approx 0.4^\circ\text{C}$ (in still air). The output current (I_{set}) has a temperature coefficient of about $0.33\%/^\circ\text{C}$. Thus the change in current due to the increase in temperature will be $(0.4)(0.33) = 0.132\%$. This is a degradation of 10 : 1 in regulation versus the true electrical effects. Thermal effects should be taken into account when d.c. regulation is critical and I_{set} is higher than $100\mu\text{A}$.

4.3 Shunt capacitance

In certain applications, the 15pF value for the shunt capacitance should be reduced:

- because of loading problems,
- because of limitation of output impedance of the current source in a.c. applications.

You can easily reduce the capacitance by adding a FET as shown in [Typical applications on page 8](#).

The value of this capacitance can be reduced by at least 3pF and regulation can be improved by an order of magnitude without any modifications of the d.c. characteristics (except for the minimum input voltage).

4.4 Noise

The current noise produced by LM134, LM234, and LM334 is about 4 times that of a transistor. If the LM134, LM234, LM334 is used as an active load for a transistor amplifier, the noise at the input will increase by about 12dB. In most cases this is acceptable, and a single amplifier can be built with a voltage gain higher than 2000.

4.5 Lead resistance

The sense voltage which determines the current of the LM134, LM234, LM334 is less than 100mV. At this level, the thermocouple effects and the connection resistance should be reduced by locating the current setting resistor close to the device. Do not use sockets for the ICs. A contact resistance of 0.7Ω is sufficient to decrease the output current by 1% at the 1mA level.

4.6 Sensing temperature

The LM134, LM234, LM334 are excellent remote controlled temperature sensors because their operation as current sources preserves their accuracy even in the case of long connecting wires. The output current is directly proportional to the absolute temperature in Kelvin degrees according to the following equation.

$$I_{\text{set}} = \frac{(227 \mu\text{V}/^\circ\text{K}) (T)}{R_{\text{set}}}$$

The calibration of the LM134, LM234, LM334 is simplified by the fact that most of the initial accuracy is due to gain limitation (slope error) and not an offset. Gain adjustment is a one point trim because the output of the device extrapolates to zero at 0°K.

Figure 10. Device calibration

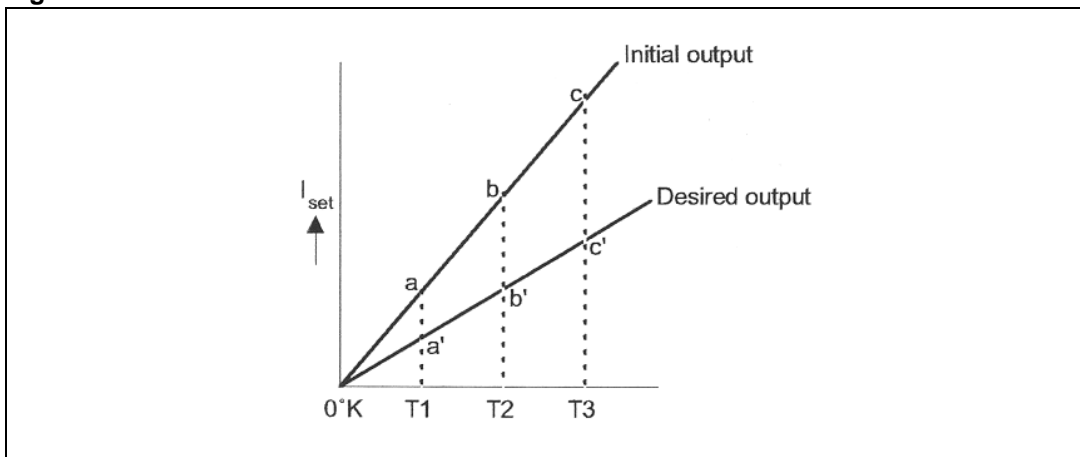

This particularity of the LM134, LM234, LM334 is illustrated in the above diagram. Line abc represents the sensor current before adjustment and line a'b'c' represents the desired output. A gain adjustment provided at T2 will move the output from b to b' and will correct the slope at the same time so that the output at T1 and T3 will be correct. This gain adjustment can be carried out by means of R_{set} or the load resistor used in the circuit. After adjustment, the slope error should be less than 1%. A low temperature coefficient for R_{set} is necessary to keep this accuracy. A 33ppm/°C temperature drift of R_{set} will give an error of 1% on the slope because the resistance follows the same temperature variations as the LM134, LM234, LM334.

Three wires are required to isolate R_{set} from the LM134, LM234, LM334. Since this solution is not recommended, metal-film resistors with a drift of less than 20ppm/°C are now available. Wirewound resistors can be used when very high stability is required.

Typical applications

Figure 11. Basic 2-terminal current source

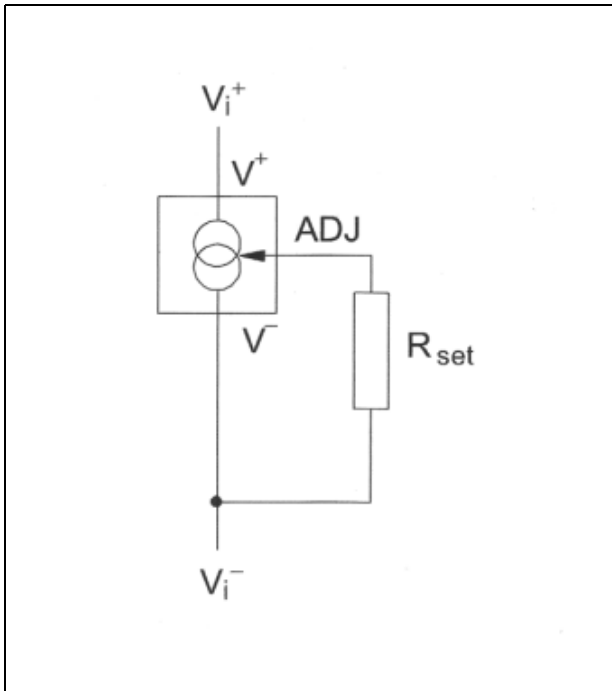

Figure 12. Alternate trimming technique

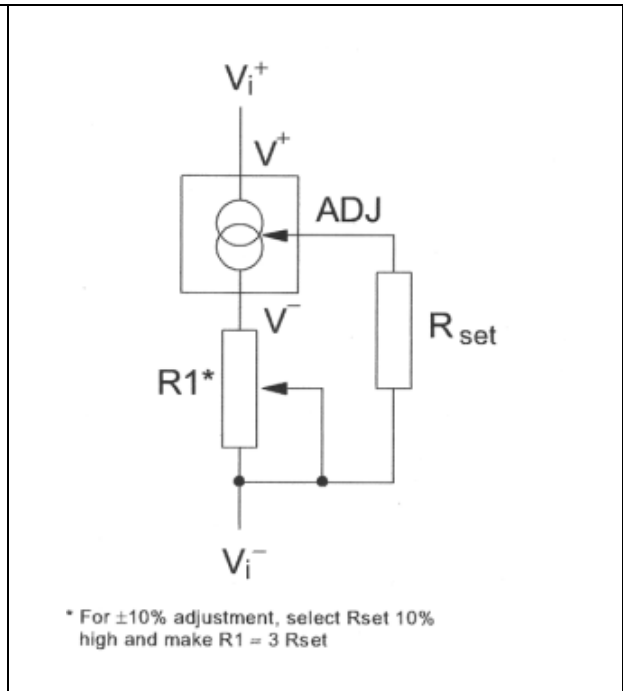

Figure 13. Terminating remote sensor for voltage output

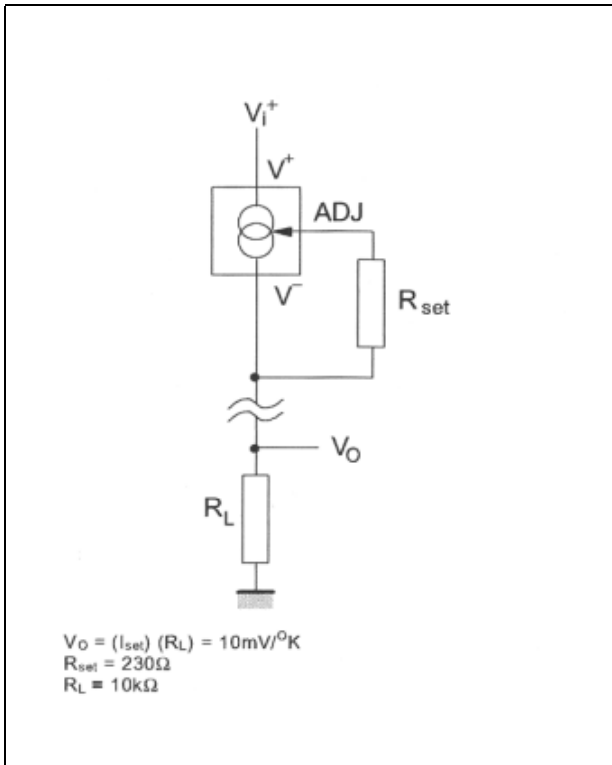

Figure 14. Zero temperature coefficient current source

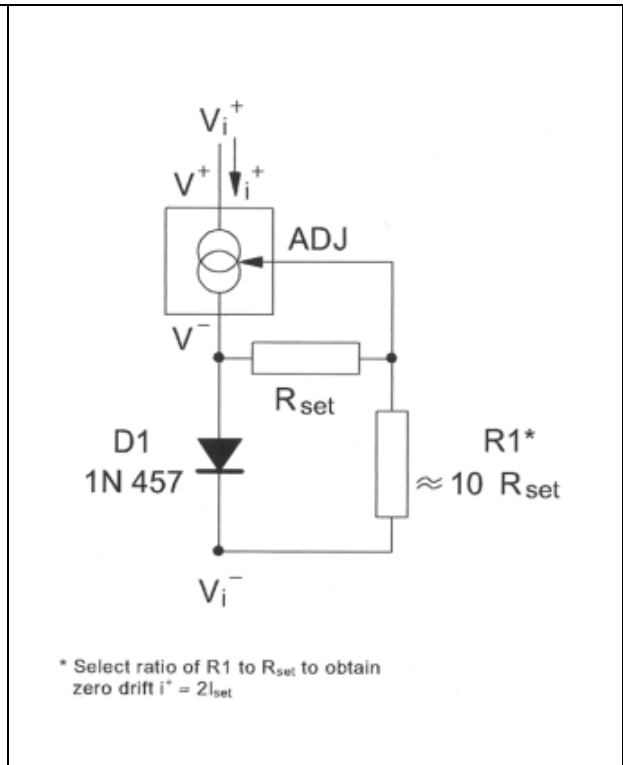

Figure 15. Low output impedance thermometer

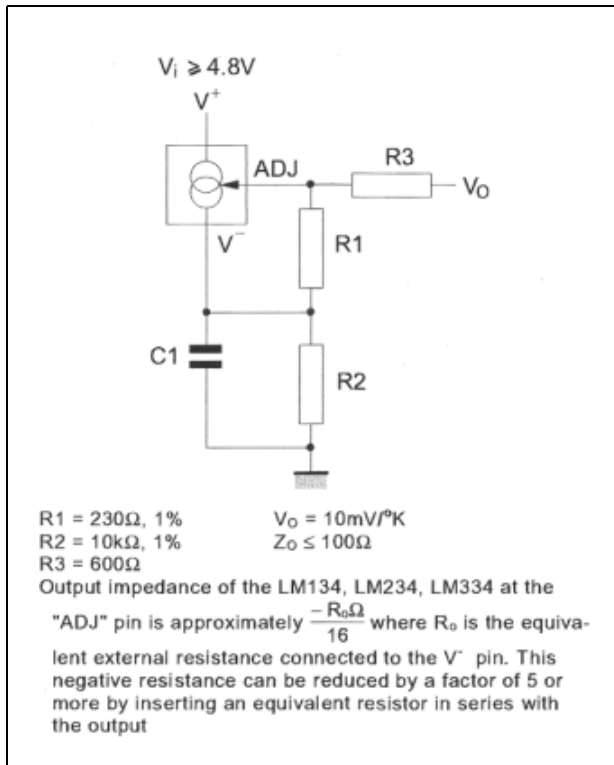

Figure 16. Low output impedance thermometer

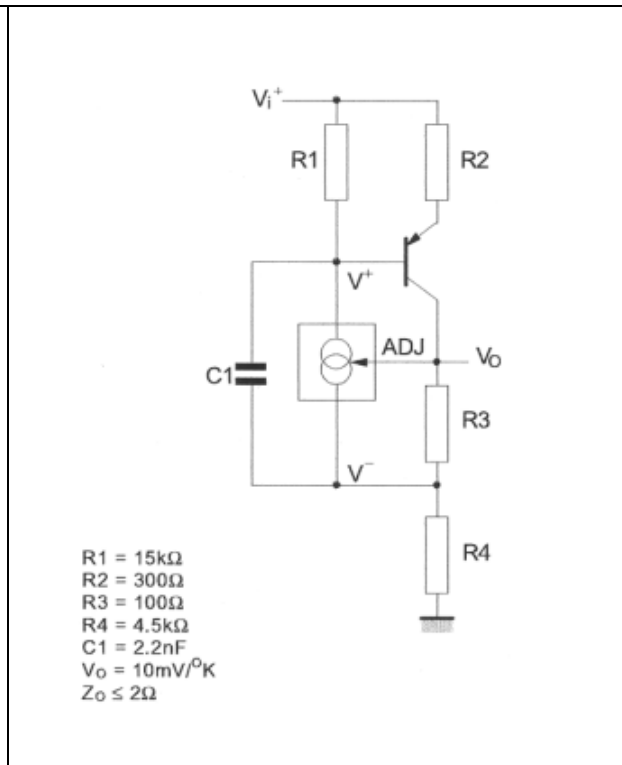

Figure 17. Micropower bias

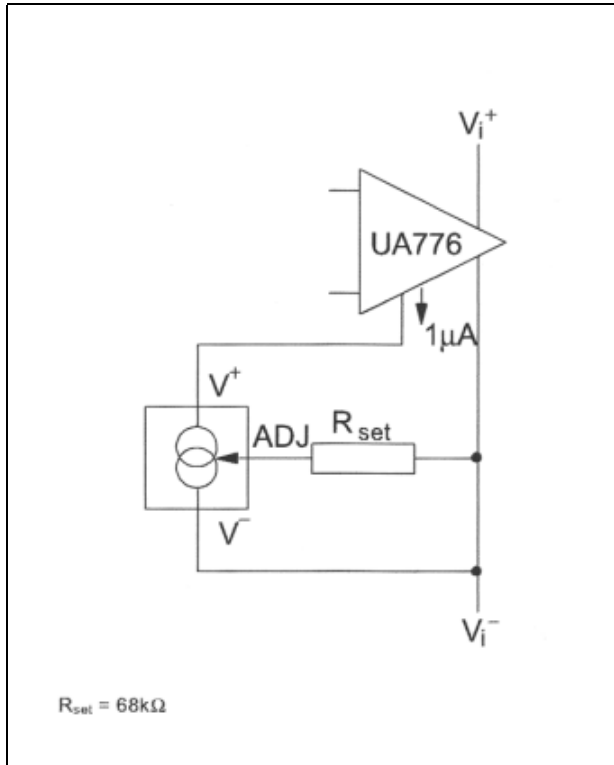

Figure 18. Low input voltage reference driver

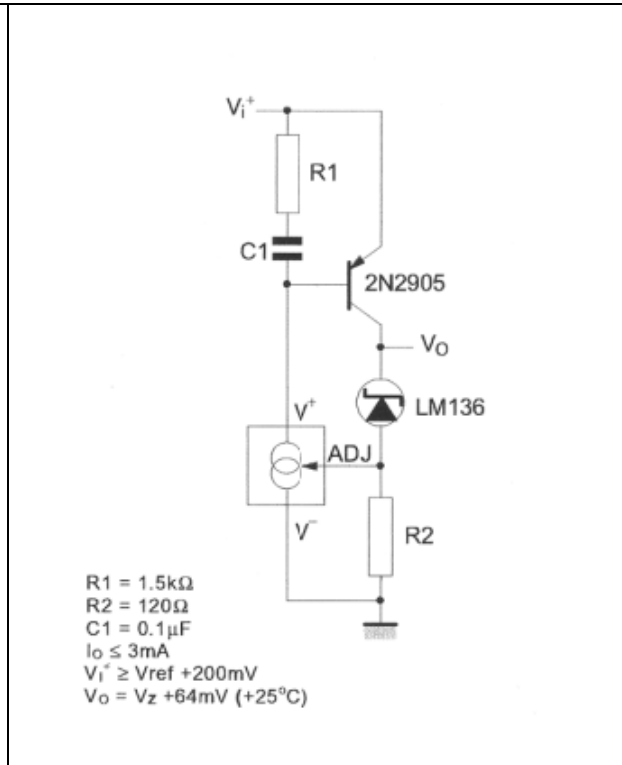

Figure 19. In-line current limiter

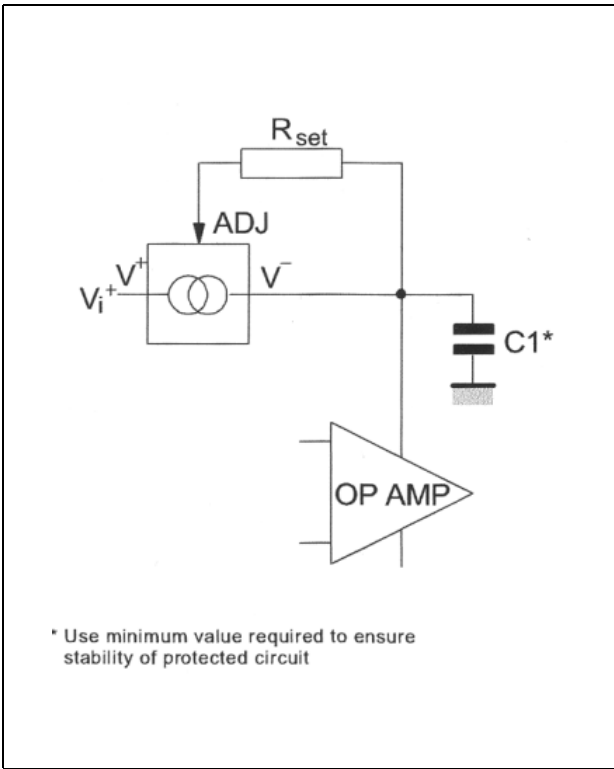
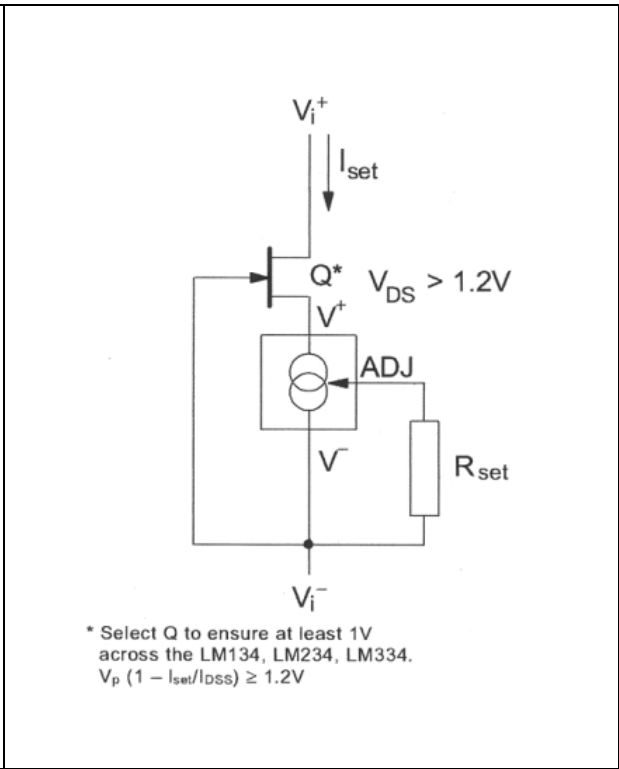

Figure 20. Fet cascading for low capacitance



5 Package information

In order to meet environmental requirements, STMicroelectronics offers these devices in ECOPACK® packages. These packages have a lead-free second level interconnect. The category of second level interconnect is marked on the package and on the inner box label, in compliance with JEDEC Standard JESD97. The maximum ratings related to soldering conditions are also marked on the inner box label. ECOPACK is an STMicroelectronics trademark. ECOPACK specifications are available at: www.st.com.

5.1 SO-8 package mechanical data

Ref.	Dimensions					
	Millimeters			Inches		
	Min.	Typ.	Max.	Min.	Typ.	Max.
A			1.75			0.069
A1	0.10		0.25	0.004		0.010
A2	1.25			0.049		
b	0.28		0.48	0.011		0.019
c	0.17		0.23	0.007		0.010
D	4.80	4.90	5.00	0.189	0.193	0.197
H	5.80	6.00	6.20	0.228	0.236	0.244
E1	3.80	3.90	4.00	0.150	0.154	0.157
e		1.27			0.050	
h	0.25		0.50	0.010		0.020
L	0.40		1.27	0.016		0.050
k	1°		8°	1°		8°
ccc			0.10			0.004

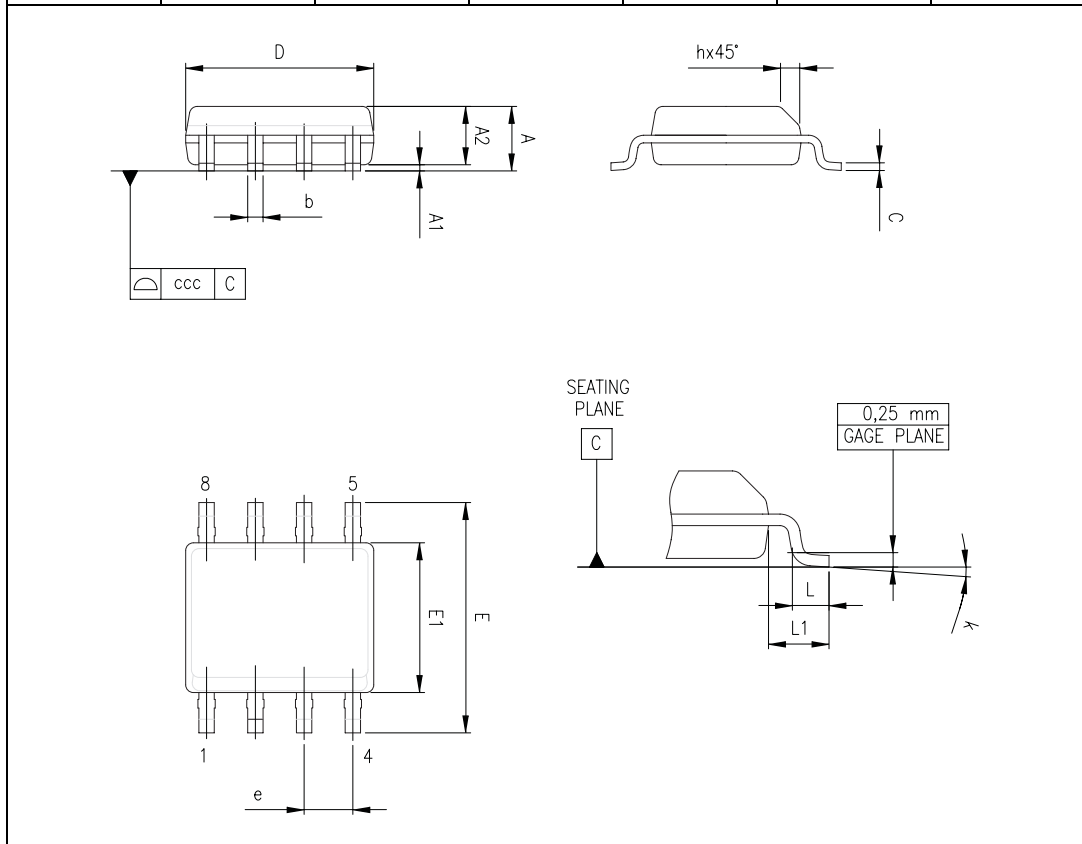

5.2 TO-92 ammpack and tape & reel package mechanical data

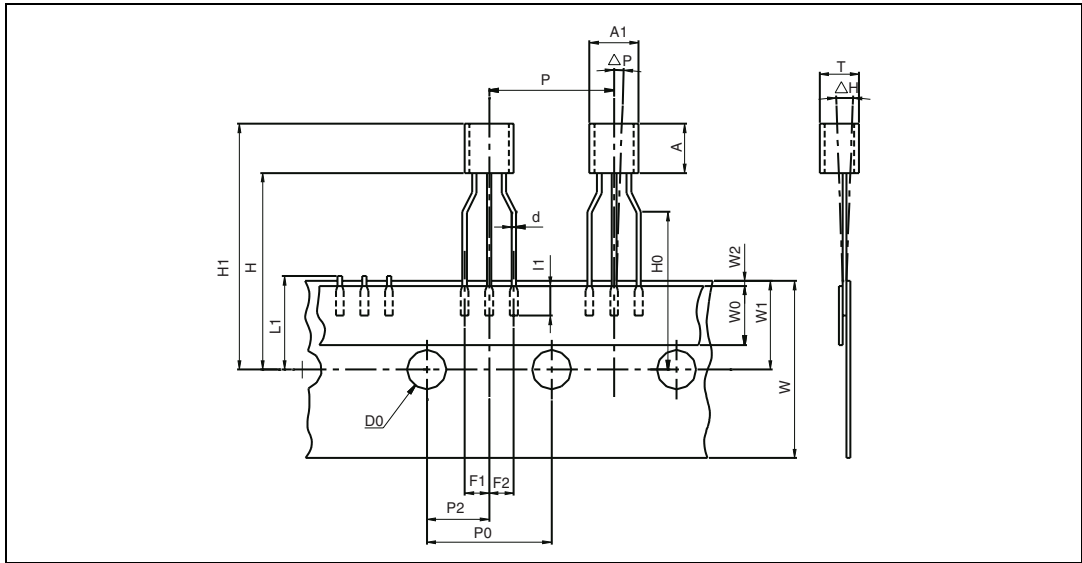

Dim.	Millimeters			Inches		
	Min.	Typ.	Max.	Min.	Typ.	Max.
AL			5.0			0.197
A			5.0			0.197
T			4.0			0.157
d		0.45			0.018	
I1	2.5			0.098		
P	11.7	12.7	13.7	0.461	0.500	0.539
PO	12.4	12.7	13	0.488	0.500	0.512
P2	5.95	6.35	6.75	0.234	0.250	0.266
F1/F2	2.4	2.5	2.8	0.094	0.098	0.110
Δh	-1	0	1	-0.039	0	0.039
ΔP	-1	0	1	-0.039	0	0.039
W	17.5	18.0	19.0	0.689	0.709	0.748
W0	5.7	6	6.3	0.224	0.236	0.248
W1	8.5	9	9.75	0.335	0.354	0.384
W2			0.5			0.020
H			20			0.787
H0	15.5	16	16.5	0.610	0.630	0.650
H1			25			0.984
DO	3.8	4.0	4.2	0.150	0.157	0.165
L1			11			0.433

5.3 TO-92 bulk package mechanical data

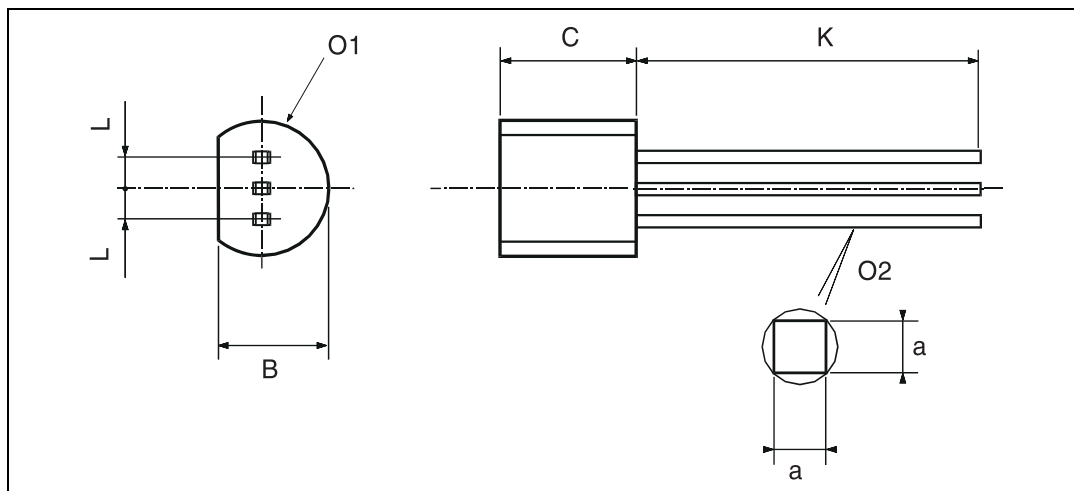

Dim.	Millimeters			Inches		
	Min.	Typ.	Max.	Min.	Typ.	Max.
L		1.27			0.05	
B	3.2	3.7	4.2	0.126	0.1457	0.1654
O1	4.45	5.00	5.2	0.1752	0.1969	0.2047
C	4.58	5.03	5.33	0.1803	0.198	0.2098
K	12.7			0.5		
O2	0.407	0.5	0.508	0.016	0.0197	0.02
a	0.35			0.0138		

6 Ordering information

Table 3. Order codes

Part number	Temperature range	Package	Packing	Marking
LM134D/DT	-55°C to +125°C	SO-8	Tube or Tape & reel	LM134
LM134Z/ZT/AP	-55°C to +125°C	TO-92	Bulk or Tape & reel or Ammopack	LM134
LM234D/DT	-25°C to +100°C	SO-8	Tube or Tape & reel	LM234
LM234Z/ZT/AP	-24°C to +100°C	TO-92	Bulk or Tape & reel or Ammopack	LM234
LM334D/DT	-0°C to +70°C	SO-8	Tube or Tape & reel	LM334
LM334Z/ZT/AP	-0°C to +70°C	TO-92	Bulk or Tape & reel or Ammopack	LM334
LM334AD/ADT	-0°C to +70°C	SO-8	Tube or Tape & reel	LM334A
LM334AZ/AZT/AAP	-0°C to +70°C	TO-92	Bulk or Tape & reel or Ammopack	LM334A

7 Revision history

Date	Revision	Changes
2-May-2003	1	Initial release.
28-Oct-2005	2	Internal revision.
29-May-2007	3	Corrected error in pinout diagram for TO-92 package on cover page (it is a bottom view, not a top view). Updated Section 5: Package information and expanded Table 3: Order codes .

Please Read Carefully:

Information in this document is provided solely in connection with ST products. STMicroelectronics NV and its subsidiaries ("ST") reserve the right to make changes, corrections, modifications or improvements, to this document, and the products and services described herein at any time, without notice.

All ST products are sold pursuant to ST's terms and conditions of sale.

Purchasers are solely responsible for the choice, selection and use of the ST products and services described herein, and ST assumes no liability whatsoever relating to the choice, selection or use of the ST products and services described herein.

No license, express or implied, by estoppel or otherwise, to any intellectual property rights is granted under this document. If any part of this document refers to any third party products or services it shall not be deemed a license grant by ST for the use of such third party products or services, or any intellectual property contained therein or considered as a warranty covering the use in any manner whatsoever of such third party products or services or any intellectual property contained therein.

UNLESS OTHERWISE SET FORTH IN ST'S TERMS AND CONDITIONS OF SALE ST DISCLAIMS ANY EXPRESS OR IMPLIED WARRANTY WITH RESPECT TO THE USE AND/OR SALE OF ST PRODUCTS INCLUDING WITHOUT LIMITATION IMPLIED WARRANTIES OF MERCHANTABILITY, FITNESS FOR A PARTICULAR PURPOSE (AND THEIR EQUIVALENTS UNDER THE LAWS OF ANY JURISDICTION), OR INFRINGEMENT OF ANY PATENT, COPYRIGHT OR OTHER INTELLECTUAL PROPERTY RIGHT.

UNLESS EXPRESSLY APPROVED IN WRITING BY AN AUTHORIZED ST REPRESENTATIVE, ST PRODUCTS ARE NOT RECOMMENDED, AUTHORIZED OR WARRANTED FOR USE IN MILITARY, AIR CRAFT, SPACE, LIFE SAVING, OR LIFE SUSTAINING APPLICATIONS, NOR IN PRODUCTS OR SYSTEMS WHERE FAILURE OR MALFUNCTION MAY RESULT IN PERSONAL INJURY, DEATH, OR SEVERE PROPERTY OR ENVIRONMENTAL DAMAGE. ST PRODUCTS WHICH ARE NOT SPECIFIED AS "AUTOMOTIVE GRADE" MAY ONLY BE USED IN AUTOMOTIVE APPLICATIONS AT USER'S OWN RISK.

Resale of ST products with provisions different from the statements and/or technical features set forth in this document shall immediately void any warranty granted by ST for the ST product or service described herein and shall not create or extend in any manner whatsoever, any liability of ST.

ST and the ST logo are trademarks or registered trademarks of ST in various countries.

Information in this document supersedes and replaces all information previously supplied.

The ST logo is a registered trademark of STMicroelectronics. All other names are the property of their respective owners.

© 2007 STMicroelectronics - All rights reserved

STMicroelectronics group of companies

Australia - Belgium - Brazil - Canada - China - Czech Republic - Finland - France - Germany - Hong Kong - India - Israel - Italy - Japan - Malaysia - Malta - Morocco - Singapore - Spain - Sweden - Switzerland - United Kingdom - United States of America

www.st.com