



# M41ST95Y\* M41ST95W

5.0 or 3.0V, 512 bit (64 bit x8) Serial RTC  
(SPI) SRAM and NVRAM Supervisor

## FEATURES SUMMARY

- 5.0 OR 3.0V OPERATING VOLTAGE
- SERIAL PERIPHERAL INTERFACE (SPI)
- NVRAM SUPERVISOR FOR EXTERNAL LPSRAM
- 2.5 TO 5.5V OSCILLATOR OPERATING VOLTAGE
- AUTOMATIC SWITCH-OVER AND DESELECT CIRCUITRY
- CHOICE OF POWER-FAIL DESELECT VOLTAGES:
  - M41ST95Y\*:  $V_{CC} = 4.5$  to  $5.5V$   
 $4.20V \leq V_{PFD} \leq 4.50V$
  - M41ST95W:  $V_{CC} = 2.7$  to  $3.6V$   
 $2.55V \leq V_{PFD} \leq 2.70V$
- 1.25V REFERENCE (FOR PFI/PFO)
- COUNTERS FOR TENTHS/HUNDRETHS OF SECONDS, SECONDS, MINUTES, HOURS, DAYS, DATE, MONTH, YEAR, AND CENTURY
- 44 BYTES OF GENERAL PURPOSE RAM
- PROGRAMMABLE ALARM and INTERRUPT FUNCTION (VALID EVEN DURING BATTERY BACK-UP MODE)
- WATCHDOG TIMER
- MICROPROCESSOR POWER-ON RESET
- BATTERY LOW FLAG
- 32kHz FREQUENCY OUTPUT AVAILABLE IMMEDIATELY UPON POWER-ON (300mil SO28 MX PACKAGE ONLY)
- AUTOMATICALLY RECORDS TIME WHEN POWER-FAIL OCCURS
- ULTRA-LOW BATTERY SUPPLY CURRENT OF 550nA (MAX)
- PACKAGING INCLUDES A 28-LEAD SOIC and SNAPHAT® TOP (to be ordered separately)
- SOIC PACKAGE PROVIDES DIRECT CONNECTION FOR A SNAPHAT TOP WHICH CONTAINS THE BATTERY and CRYSTAL

Figure 1. 28-pin SOIC Package\*

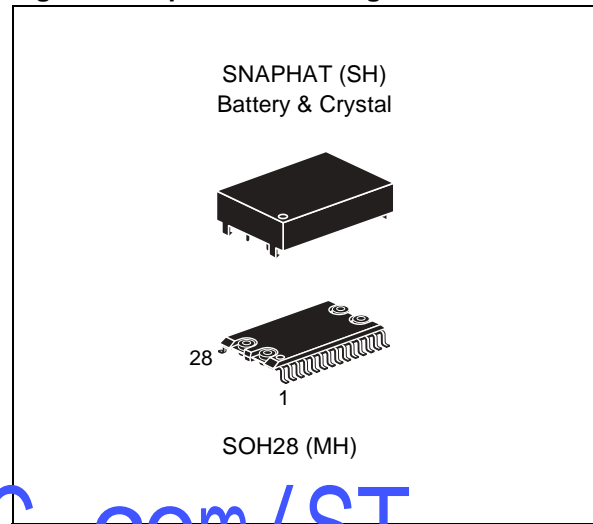
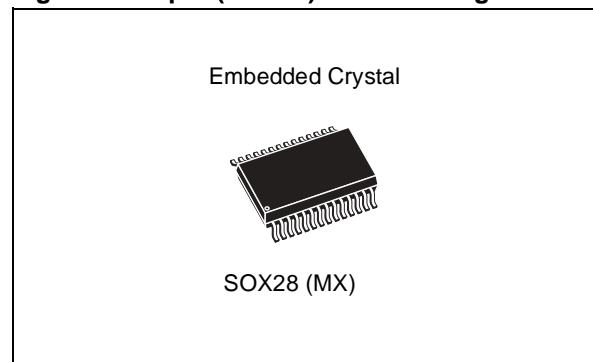


Figure 2. 28-pin (300mil) SOIC Package



\* Contact Local Sales Office

**TABLE OF CONTENTS**

**FEATURES SUMMARY** ..... 1

    Figure 1. 28-pin SOIC Package\* ..... 1

    Figure 2. 28-pin (300mil) SOIC Package ..... 1

**SUMMARY DESCRIPTION** ..... 4

    Figure 3. Logic Diagram ..... 5

    Table 1. Signal Names ..... 5

    Figure 4. 28-pin SOIC Connections ..... 6

    Figure 5. 28-pin, 300mil SOIC (MX) Connections ..... 6

    Figure 6. Block Diagram ..... 7

    Figure 7. Hardware Hookup ..... 8

**OPERATION** ..... 9

**SPI Bus Characteristics** ..... 9

**Signal Description** ..... 10

    Table 2. Function Table ..... 10

    Figure 8. Data and Clock Timing ..... 10

    Figure 9. Input Timing Requirements ..... 11

    Figure 10. Output Timing Requirements ..... 11

    Figure 11. WRITE Cycle Timing: RTC and External SRAM Control Signals ..... 11

    Table 3. AC Characteristics ..... 12

**READ and WRITE Cycles** ..... 13

    Figure 12. READ Mode Sequence ..... 13

    Figure 13. WRITE Mode Sequence ..... 14

**Data Retention Mode** ..... 14

**CLOCK OPERATION** ..... 15

**Power-down Time-Stamp** ..... 15

**TIMEKEEPER® Registers** ..... 15

    Table 4. TIMEKEEPER® Register Map ..... 16

**Calibrating the Clock** ..... 17

**Setting Alarm Clock Registers** ..... 17

    Figure 14. Alarm Interrupt Reset Waveform ..... 18

    Table 5. Alarm Repeat Mode ..... 18

    Figure 15. Back-up Mode Alarm Waveforms ..... 19

**Watchdog Timer** ..... 19

**Square Wave Output** ..... 20

    Table 6. Square Wave Output Frequency ..... 20

**Full-time F<sub>32k</sub> Square Wave Output** ..... 20

    (Available only in 28-pin, 300mil SOIC (MX) package) ..... 20

**Power-on Reset** ..... 21

**Reset Input (RSTIN1 and RSTIN2)** ..... 21

    Figure 16. RSTIN1 and RSTIN2 Timing Waveforms ..... 21



Table 7. Reset AC Characteristics. . . . .	21
<b>Power-fail INPUT/OUTPUT . . . . .</b>	<b>22</b>
Figure 17. Power-Fail Comparator Hookup . . . . .	22
<b>Century Bit . . . . .</b>	<b>23</b>
<b>Output Driver Pin. . . . .</b>	<b>23</b>
<b>Battery Low Warning. . . . .</b>	<b>23</b>
<b>t<sub>REC</sub> Bit . . . . .</b>	<b>23</b>
<b>Preferred Power-on Defaults . . . . .</b>	<b>23</b>
Table 8. t <sub>REC</sub> Definitions . . . . .	23
Table 9. Default Values . . . . .	23
Figure 18. Crystal Accuracy Across Temperature . . . . .	24
Figure 19. Calibration Waveform . . . . .	24
<b>MAXIMUM RATING. . . . .</b>	<b>25</b>
Table 10. Absolute Maximum Ratings. . . . .	25
<b>DC AND AC PARAMETERS. . . . .</b>	<b>26</b>
Table 11. DC and AC Measurement Conditions . . . . .	26
Figure 20. AC Testing Input/Output Waveforms. . . . .	26
Table 12. Capacitance. . . . .	26
Table 13. DC Characteristics. . . . .	27
Figure 21. Power Down/Up Mode AC Waveforms . . . . .	28
Table 14. Power Down/Up AC Characteristics . . . . .	28
<b>PACKAGE MECHANICAL INFORMATION . . . . .</b>	<b>29</b>
Figure 22. SOH28 – 28-lead Plastic Small Outline, Battery SNAPHAT, Package Outline . . . . .	29
Table 15. SOH28 – 28-lead Plastic Small Outline, battery SNAPHAT, Package Mechanical Data . . . . .	29
Figure 23. SH – 4-pin SNAPHAT Housing for 48mAh Battery & Crystal, Package Outline . . . . .	30
Table 16. SH – 4-pin SNAPHAT Housing for 48mAh Battery & Crystal, Package Mechanical Data . . . . .	30
Figure 24. SH – 4-pin SNAPHAT Housing for 120mAh Battery & Crystal, Package Outline . . . . .	31
Table 17. SH – 4-pin SNAPHAT Housing for 120mAh Battery & Crystal, Package Mech. Data. . . . .	31
Figure 25. SOX28 – 28-lead Plastic Small Outline, 300mils, Embedded Crystal, Outline . . . . .	32
Table 18. SOX28 – 28-lead Plastic Small, 300mils, Embedded Crystal, Package Mech. Data . . . . .	32
<b>PART NUMBERING . . . . .</b>	<b>33</b>
Table 19. Ordering Information Scheme . . . . .	33
Table 20. SNAPHAT Battery Table . . . . .	33
<b>REVISION HISTORY. . . . .</b>	<b>34</b>
Table 21. Document Revision History . . . . .	34

## SUMMARY DESCRIPTION

The M41ST95Y/W Serial TIMEKEEPER® SRAM is a low power, 512-bit static CMOS SRAM organized as 64 words by 8 bits. A built-in 32,768Hz oscillator (external crystal controlled) and 8 bytes of the SRAM (see [Table 4., page 16](#)) are used for the clock/calendar function and are configured in binary coded decimal (BCD) format.

An additional 12 bytes of RAM provide status/control of Alarm, Watchdog and Square Wave functions. Addresses and data are transferred serially via a serial SPI interface. The built-in address register is incremented automatically after each WRITE or READ data byte. The M41ST95Y/W has a built-in power sense circuit which detects power failures and automatically switches to the battery supply when a power failure occurs. The energy needed to sustain the SRAM and clock operations can be supplied by a small lithium button-cell supply when a power failure occurs. Functions available to the user include a non-volatile, time-of-day clock/calendar, Alarm interrupts, Watchdog Timer and programmable Square Wave output. Other features include a Power-On Reset as well as two additional debounced inputs ( $\overline{\text{RSTIN1}}$  and  $\overline{\text{RSTIN2}}$ ) which can also generate an output Reset ( $\overline{\text{RST}}$ ). The eight clock address locations contain the century, year, month, date, day, hour, minute, second and tenths/hundredths of a second in 24 hour BCD format. Corrections for 23, 29 (leap year - valid until year 2100), 30 and 31 day months are made automatically.

The M41ST95Y/W is supplied in a 28-lead SOIC SNAPHAT® (MH) package (which integrates both crystal and battery in a single SNAPHAT top), or a 28-pin, 300mil SOIC package (MX) which includes an embedded 32kHz crystal.

The 28-pin, 330mil SOIC provides sockets with gold plated contacts at both ends for direct connection to a separate SNAPHAT housing containing the battery and crystal. The unique design allows the SNAPHAT battery/crystal package to be mounted on top of the SOIC package after the completion of the surface mount process.

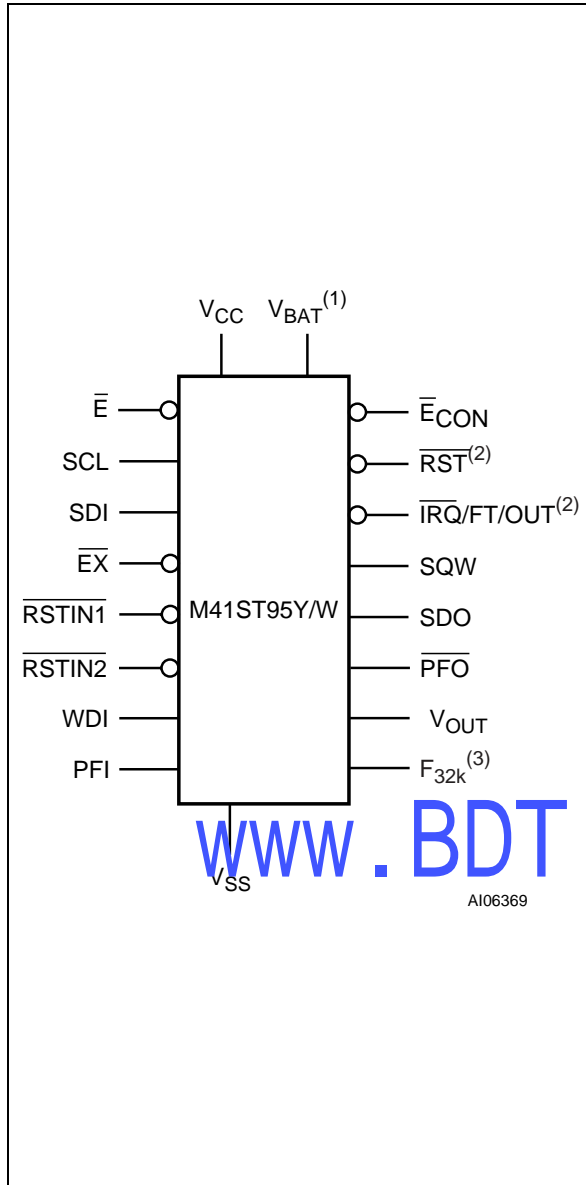
Insertion of the SNAPHAT housing after reflow prevents potential battery and crystal damage due to the high temperatures required for device surface-mounting. The SNAPHAT housing is also keyed to prevent reverse insertion.

The SNAPHAT SOIC and battery/crystal packages are shipped separately in plastic anti-static tubes or in Tape & Reel form. For the 28-lead SOIC, the battery/crystal package (e.g., SNAPHAT) part number is "M4TXX-BR12SH" (see [Table 20., page 33](#)).

**Caution:** Do not place the SNAPHAT battery/crystal top in conductive foam, as this will drain the lithium button-cell battery.

The 300mil, embedded crystal SOIC requires only a user-supplied battery to provide non-volatile operation.

Figure 3. Logic Diagram



Note: 1. For SOX28 package only.  
 2. Open drain  
 3. Available only in 28-pin, 300mil SOIC (MX) package.

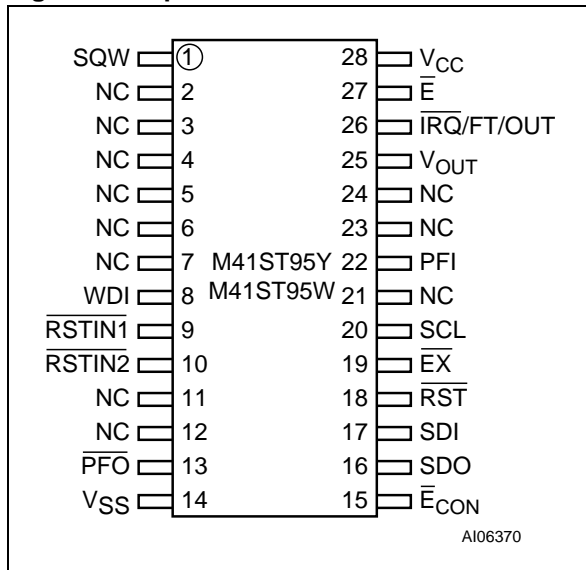
Table 1. Signal Names

E <sub>CON</sub>	Conditioned Chip Enable Output
$\overline{E}X$	External Chip Enable
E	Chip Enable
$\overline{I}RQ/FT/OUT$	Interrupt/Frequency Test/Out Output (Open Drain)
$\overline{R}ST$	Reset Output (Open Drain)
$\overline{R}STIN1$	Reset 1 Input
RSTIN2	Reset 2 Input
SCL	Serial Clock Input
SDI	Serial Data Input
SDO	Serial Data Output
SQW	Square Wave Output
F <sub>32k</sub> <sup>(2)</sup>	32kHz Square Wave Output
WDI	Watchdog Input
PFI	Power-Fail Input
PFO	Power-Fail Output
V <sub>OUT</sub>	Voltage Output
V <sub>BAT</sub> <sup>(1)</sup>	Battery Supply Voltage
V <sub>CC</sub>	Supply Voltage
V <sub>SS</sub>	Ground
NC	No Connect
NF	No Function

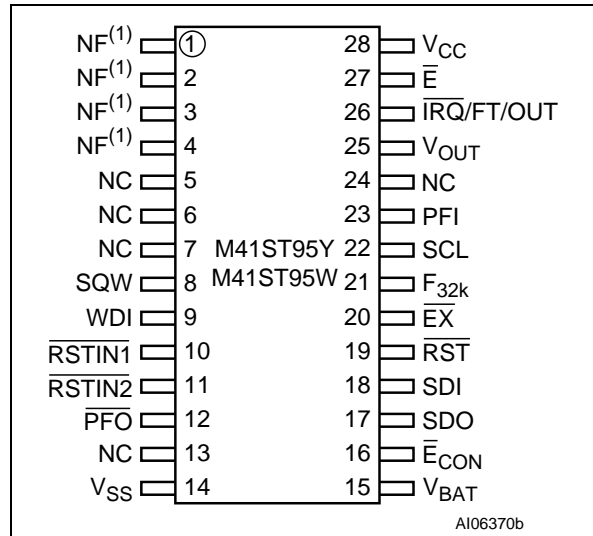
Note: 1. For SOX28 package only.  
 2. Available only in 28-pin, 300mil SOIC (MX) package.

**M41ST95Y\*, M41ST95W**

**Figure 4. 28-pin SOIC Connections**



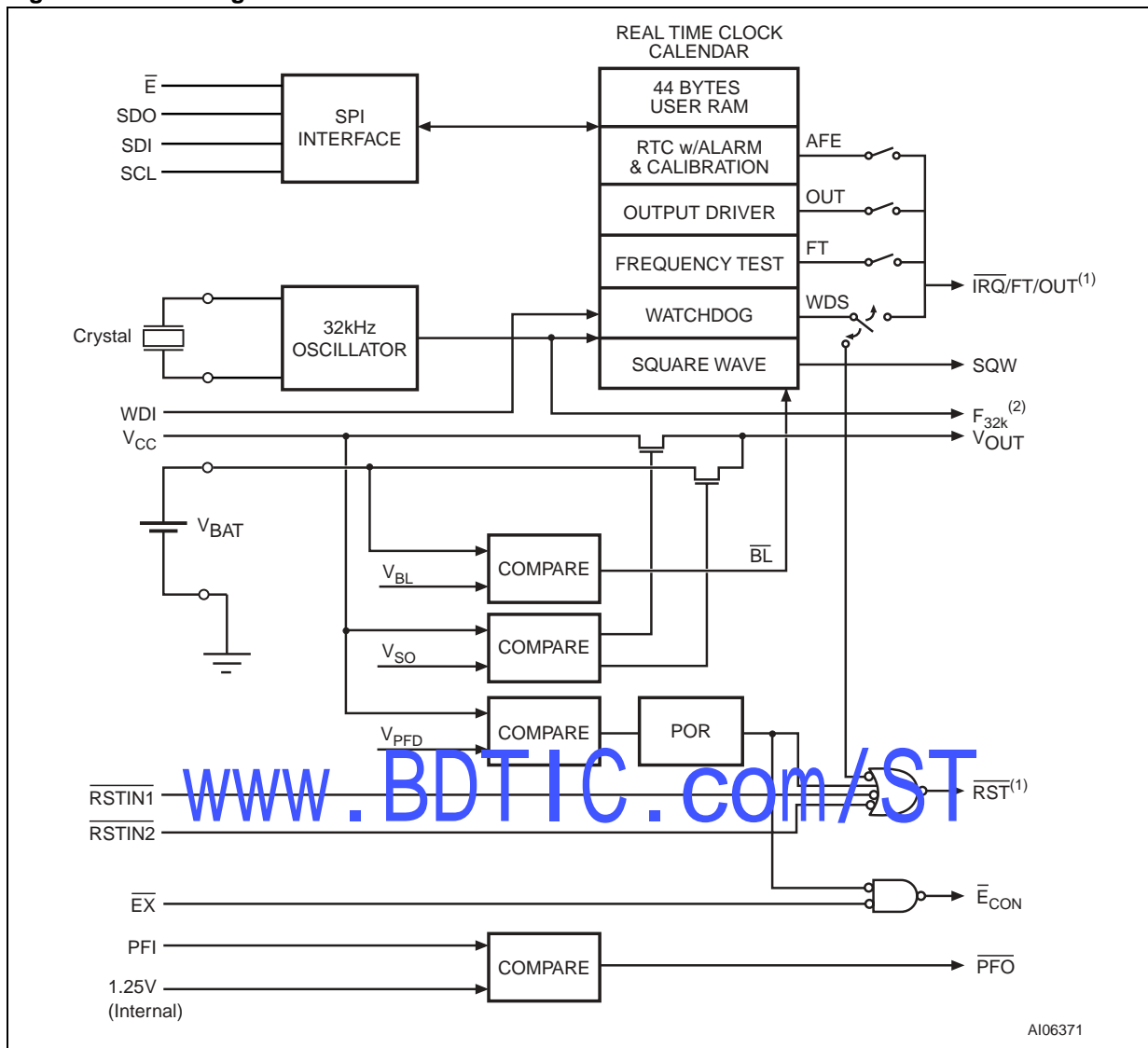
**Figure 5. 28-pin, 300mil SOIC (MX) Connections**



Note: 1. No Function (NF) pins (1, 2, 3, and 4) pins must be tied to V<sub>SS</sub>, and are internally shorted together.

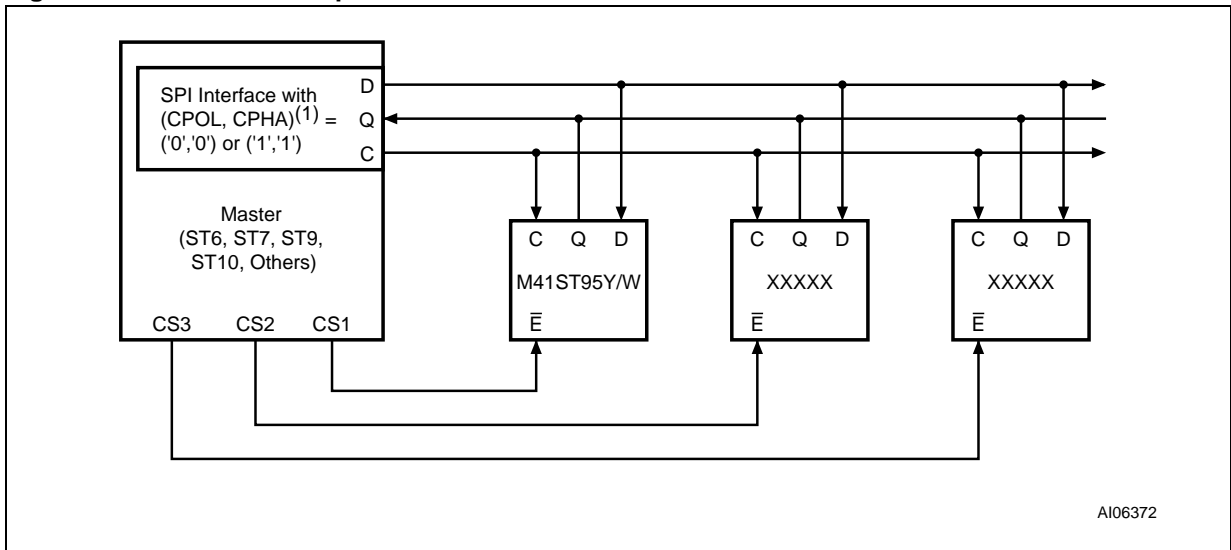
[www.BDTIC.com/ST](http://www.BDTIC.com/ST)

Figure 6. Block Diagram



Note: 1. Open Drain Output  
 2. Available only in 28-pin, 300mil SOIC (MX) package.

Figure 7. Hardware Hookup



Note: 1. CPOL (Clock Polarity) and CPHA (Clock Phase) are bits that may be set in the SPI Control Register of the MCU.

[www.BDTIC.com/ST](http://www.BDTIC.com/ST)



## OPERATION

The M41ST95Y/W clock operates as a slave device on the SPI serial bus. Each memory device is accessed by a simple serial interface that is SPI bus compatible. The bus signals are SCL, SDI and SDO (see [Table 1., page 5](#) and [Figure 7., page 8](#)). The device is selected when the Chip Enable input ( $\bar{E}$ ) is held low. All instructions, addresses and data are shifted serially in and out of the chip. The most significant bit is presented first, with the data input (SDI) sampled on the first rising edge of the clock (SCL) after the Chip Enable ( $\bar{E}$ ) goes low. The 64 bytes contained in the device can then be accessed sequentially in the following order:

1. Tenths/Hundredths of a Second Register
2. Seconds Register
3. Minutes Register
4. Century/Hours Register
5. Day Register
6. Date Register
7. Month Register
8. Year Register
9. Control Register
10. Watchdog Register
- 11 - 16. Alarm Registers
- 17 - 19. Reserved
20. Square Wave Register
- 21 - 64. User RAM

The M41ST95Y/W clock continually monitors  $V_{CC}$  for an out-of-tolerance condition. Should  $V_{CC}$  fall below  $V_{PFD}$ , the device terminates an access in progress and resets the device address counter. Inputs to the device will not be recognized at this time to prevent erroneous data from being written to the device from an out-of-tolerance system. When  $V_{CC}$  falls below  $V_{SO}$ , the device automatically switches over to the battery and powers down into an ultra low current mode of operation to conserve battery life. As system power returns and  $V_{CC}$  rises above  $V_{SO}$ , the battery is disconnected,

and the power supply is switched to external  $V_{CC}$ . Write protection continues until  $V_{CC}$  reaches  $V_{PFD}(\text{min})$  plus  $t_{REC}(\text{min})$ . For more information on Battery Storage Life refer to Application Note AN1012.

### SPI Bus Characteristics

The Serial Peripheral interface (SPI) bus is intended for synchronous communication between different ICs. It consists of four signal lines: Serial Data Input (SDI), Serial Data Output (SDO), Serial Clock (SCL) and a Chip Enable ( $\bar{E}$ ).

By definition a device that gives out a message is called "transmitter," the receiving device that gets the message is called "receiver." The device that controls the message is called "master." The devices that are controlled by the master are called "slaves."

The  $\bar{E}$  input is used to initiate and terminate a data transfer. The SCL input is used to synchronize data transfer between the master (micro) and the slave (M41ST95Y/W) devices.

The SCL input, which is generated by the microcontroller, is active only during address and data transfer to any device on the SPI bus (see [Figure 7., page 8](#)).

The M41ST95Y/W can be driven by a microcontroller with its SPI peripheral running in either of the two following modes:

(CPOL, CPHA) = ('0', '0') or  
(CPOL, CPHA) = ('1', '1').

For these two modes, input data (SDI) is latched in by the low-to-high transition of clock SCL, and output data (SDO) is shifted out on the high-to-low transition of SCL (see [Table 2., page 10](#) and [Figure 8., page 10](#)).

There is one clock for each bit transferred. Address and data bits are transferred in groups of eight bits. Due to memory size the second most significant address bit is a Don't Care (address bit 6).

**Signal Description**

**Serial Data Output (SDO).** The output pin is used to transfer data serially out of the Memory. Data is shifted out on the falling edge of the serial clock.

**Serial Data Input (SDI).** The input pin is used to transfer data serially into the device. Instructions, addresses, and the data to be written, are each received this way. Input is latched on the rising edge of the serial clock.

**Serial Clock (SCL).** The serial clock provides the timing for the serial interface (as shown in Figure 9., page 11 and Figure 10., page 11). The W/R Bit, addresses, or data are latched, from the input pin, on the rising edge of the clock input. The output data on the SDO pin changes state after the falling edge of the clock input.

The M41ST95Y/W can be driven by a microcontroller with its SPI peripheral running in either of the two following modes:

(CPOL, CPHA) = ('0', '0') or

(CPOL, CPHA) = ('1', '1').

For these two modes, input data (SDI) is latched in by the low-to-high transition of clock SCL, and output data (SDO) is shifted out on the high-to-low transition of SCL (see Table 2 and Figure 8).

**Chip Enable ( $\bar{E}$ ).** When  $\bar{E}$  is high, the memory device is deselected, and the SDO output pin is held in its high impedance state.

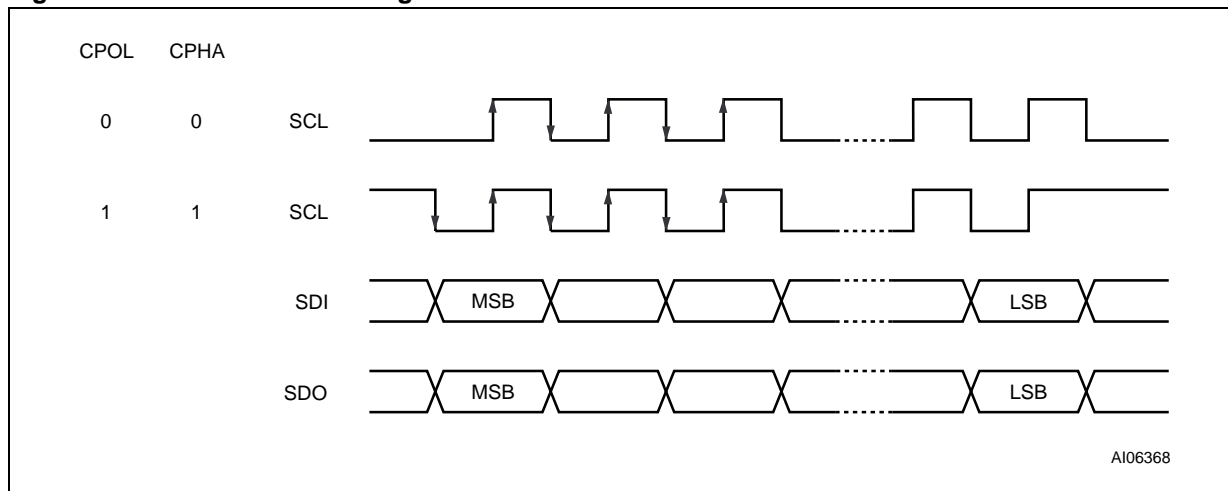
After power-on, a high-to-low transition on  $\bar{E}$  is required prior to the start of any operation.

**Table 2. Function Table**

Mode	$\bar{E}$	SCL	SDI	SDO
Disable Reset	H	Input Disabled	Input Disabled	High Z
WRITE	L		Data Bit latch	High Z
READ	L		X	Next data bit shift <sup>(1)</sup>

Note: 1. SDO remains at High Z until eight bits of data are ready to be shifted out during a READ.

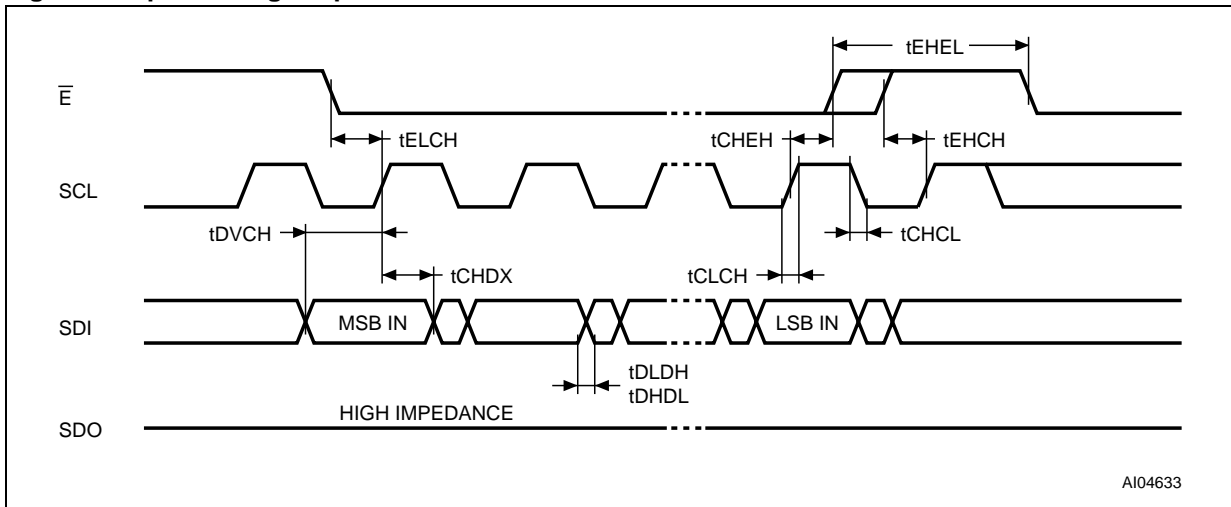
**Figure 8. Data and Clock Timing**



AI06368

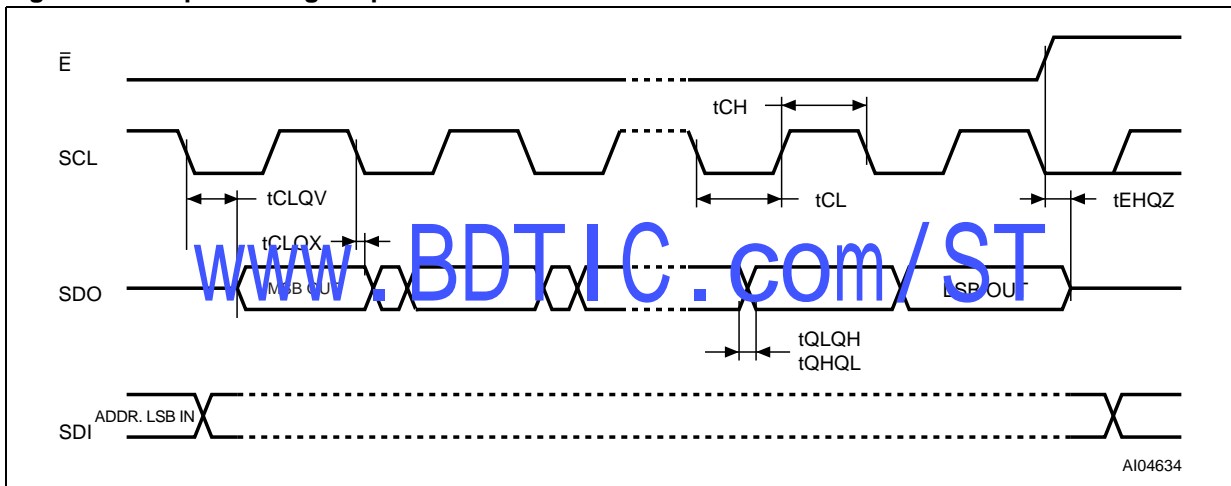


Figure 9. Input Timing Requirements



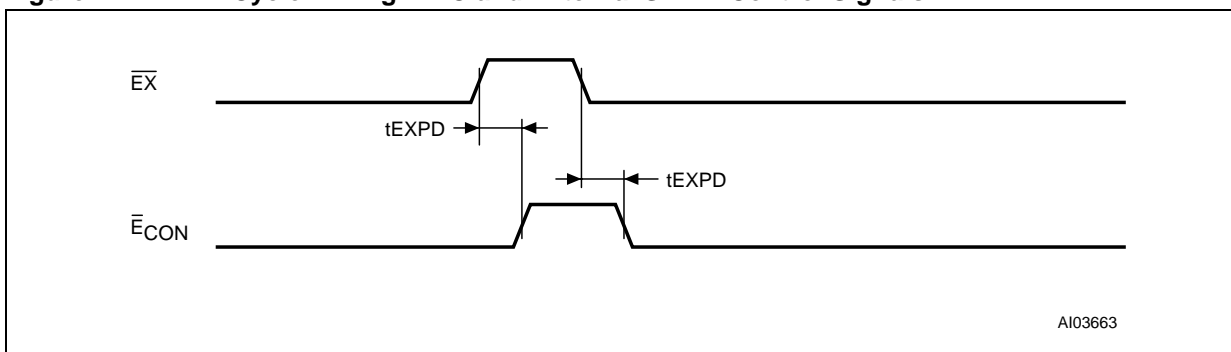
AI04633

Figure 10. Output Timing Requirements



AI04634

Figure 11. WRITE Cycle Timing: RTC and External SRAM Control Signals



AI03663

**Table 3. AC Characteristics**

Symbol	Parameter <sup>(1)</sup>	Min	Max	Unit	
f <sub>SCL</sub>	Serial Clock Input Frequency	DC	2	MHz	
t <sub>CH</sub> <sup>(2)</sup>	Clock High	200		ns	
t <sub>CHCL</sub> <sup>(3)</sup>	Clock Transition (Fall Time)		1	µs	
t <sub>CHDX</sub>	Serial Clock Input High to Input Data Transition	50		ns	
t <sub>CHEH</sub>	Serial Clock Input High to Chip Enable High	200		ns	
t <sub>CL</sub> <sup>(2)</sup>	Clock Low	200		ns	
t <sub>CLCH</sub> <sup>(3)</sup>	Clock Transition (Rise Time)		1	µs	
t <sub>CLQV</sub>	Serial Clock Input Low to Output Valid		150	ns	
t <sub>CLQX</sub>	Serial Clock Input Low to Output Data Transition	0		ns	
t <sub>DHDL</sub> <sup>(3)</sup>	Input Data Transition (Fall Time)		1	µs	
t <sub>DLDH</sub> <sup>(3)</sup>	Input Data Transition (Rise Time)		1	µs	
t <sub>DVCH</sub>	Input Data to Serial Clock Input High	40		ns	
t <sub>EHCH</sub>	Chip Enable High to Serial Clock Input High	200		ns	
t <sub>EHEL</sub>	Chip Enable High to Chip Enable Low	200		ns	
t <sub>EHQZ</sub> <sup>(3)</sup>	Chip Enable High to Output High-Z		250	ns	
t <sub>ELCH</sub>	Chip Enable Low to Serial Clock Input High	200		ns	
t <sub>QHQL</sub> <sup>(3)</sup>	Output Data Transition (Fall Time)		100	ns	
t <sub>QLQH</sub> <sup>(3)</sup>	Output Data Transition (Rise Time)		100	ns	
t <sub>EXPD</sub>	$\bar{E}X$ to $\bar{E}CON$ Propagation Delay	M41ST95Y		10	ns
		M41ST95W		15	ns

Note: 1. Valid for Ambient Operating Temperature: T<sub>A</sub> = -40 to 85°C; V<sub>CC</sub> = 4.5 to 5.5V or 2.7 to 3.6V (except where noted).

2. t<sub>CH</sub> + t<sub>CL</sub> ≥ 1/f<sub>SCL</sub>

3. Value guaranteed by design, not 100% tested in production.

### READ and WRITE Cycles

Address and data are shifted MSB first into the Serial Data Input (SDI) and out of the Serial Data Output (SDO). Any data transfer considers the first bit to define whether a READ or WRITE will occur. This is followed by seven bits defining the address to be read or written. Data is transferred out of the SDO for a READ operation and into the SDI for a WRITE operation. The address is always the second through the eighth bit written after the Enable ( $\bar{E}$ ) pin goes low. If the first bit is a '1,' one or more WRITE cycles will occur. If the first bit is a '0,' one or more READ cycles will occur (see Figure 12 and Figure 13., page 14).

Data transfers can occur one byte at a time or in multiple byte burst mode, during which the address pointer will be automatically incremented. For a single byte transfer, one byte is read or written and then  $\bar{E}$  is driven high. For a multiple byte transfer all that is required is that  $\bar{E}$  continue to remain low. Under this condition, the address pointer will continue to increment as stated previously. Incrementing will continue until the device is deselected by taking  $\bar{E}$  high. The address will wrap to 00h after incrementing to 3Fh.

The system-to-user transfer of clock data will be halted whenever the address being read is a clock address (00h to 07h). Although the clock continues to maintain the correct time, this will prevent updates of time and date during either a READ or WRITE of these address locations by the user. The update will resume either due to a deselect condition or when the pointer increments to a non-clock or RAM address (08h to 3Fh).

**Note:** This is true both in READ and WRITE mode.

Figure 12. READ Mode Sequence

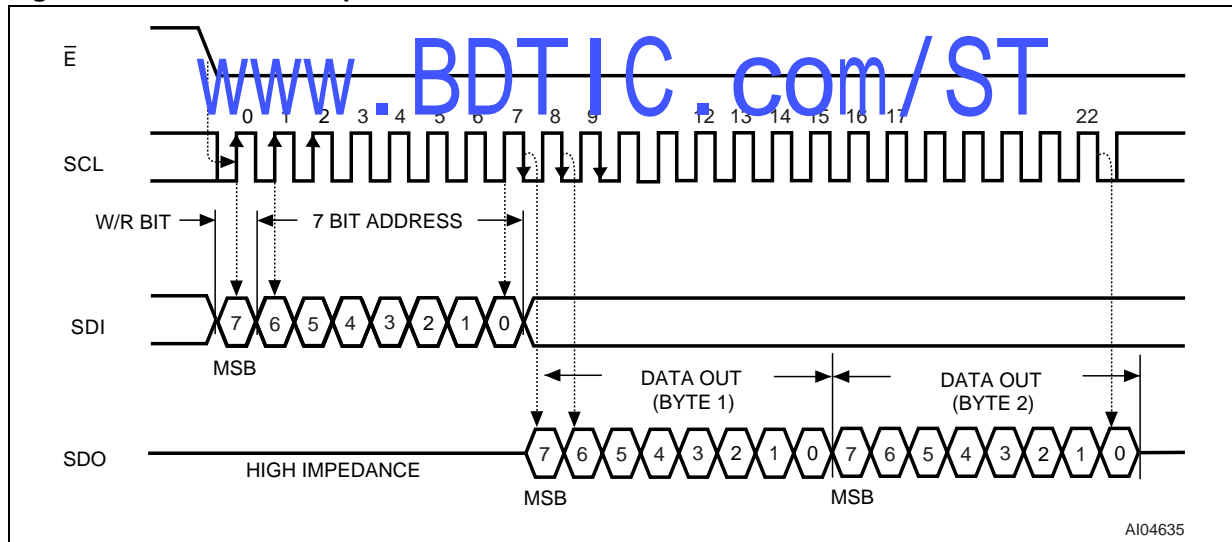
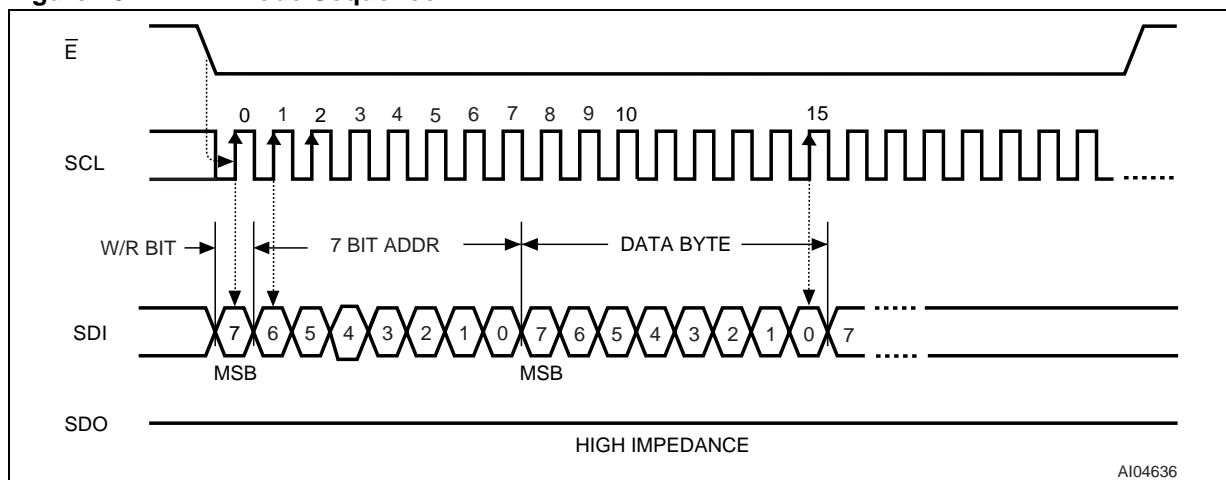


Figure 13. WRITE Mode Sequence



### Data Retention Mode

With valid  $V_{CC}$  applied, the M41ST95Y/W can be accessed as described above with READ or WRITE Cycles. Should the supply voltage decay, the M41ST95Y/W will automatically deselect, write protecting itself (and any external SRAM) when  $V_{CC}$  falls between  $V_{PFD(max)}$  and  $V_{PFD(min)}$ . This is accomplished by internally inhibiting access to the clock registers. At this time, the Reset pin (RST) is driven active and will remain active until  $V_{CC}$  returns to nominal levels. External RAM accesses are inhibited in a similar manner by forcing  $\bar{E}_{CON}$  to a high level. This level is within 0.2 volts of the  $V_{BAT}$ .  $\bar{E}_{CON}$  will remain at this level as long as  $V_{CC}$  remains at an out-of-tolerance condition. When  $V_{CC}$  falls below the Battery Back-up Switchover Voltage ( $V_{SO}$ ), power input is switched from the  $V_{CC}$  pin to the SNAPHAT<sup>®</sup> battery, and the clock registers and external SRAM are maintained from the attached battery supply.

All outputs become high impedance. The  $V_{OUT}$  pin is capable of supplying 100  $\mu A$  of current to the attached memory with less than 0.3 volts drop under this condition. On power up, when  $V_{CC}$  returns to a nominal value, write protection continues for  $t_{REC}$  by inhibiting  $\bar{E}_{CON}$ . The  $\bar{RST}$  signal also remains active during this time (see Figure 21., page 28).

**Note:** Most low power SRAMs on the market today can be used with the M41ST95Y/W RTC SUPERVISOR. There are, however some criteria which should be used in making the final choice of an SRAM to use.

The SRAM must be designed in a way where the chip enable input disables all other inputs to the SRAM. This allows inputs to the M41ST95Y/W and SRAMs to be "Don't Care" once  $V_{CC}$  falls below  $V_{PFD(min)}$ . The SRAM should also guarantee data retention down to  $V_{CC} = 2.0$  volts. The chip enable access time must be sufficient to meet the system needs with the chip enable output propagation delays included. If the SRAM includes a second chip enable pin ( $\bar{E}2$ ), this pin should be tied to  $V_{OUT}$ .

If data retention lifetime is a critical parameter for the system, it is important to review the data retention current specifications for the particular SRAMs being evaluated. Most SRAMs specify a data retention current at 3.0 volts. Manufacturers generally specify a typical condition for room temperature along with a worst case condition (generally at elevated temperatures). The system level requirements will determine the choice of which value to use. The data retention current value of the SRAMs can then be added to the  $I_{BAT}$  value of the M41ST95Y/W to determine the total current requirements for data retention. The available battery capacity for the SNAPHAT<sup>®</sup> of your choice can then be divided by this current to determine the amount of data retention available (see 20).

For a further more detailed review of lifetime calculations, please see Application Note AN1012.

## CLOCK OPERATION

The eight byte clock register (see [Table 4., page 16](#)) is used to both set the clock and to read the date and time from the clock, in a binary coded decimal format. Tenths/Hundredths of Seconds, Seconds, Minutes, and Hours are contained within the first four registers.

**Note:** The Tenths/Hundredths of Seconds cannot be written to any value other than "00."

Bits D6 and D7 of Clock Register 03h (Century/Hours Register) contain the CENTURY ENABLE Bit (CEB) and the CENTURY Bit (CB). Setting CEB to a '1' will cause CB to toggle, either from '0' to '1' or from '1' to '0' at the turn of the century (depending upon its initial state). If CEB is set to a '0,' CB will not toggle. Bits D0 through D2 of Register 04h contain the Day (day of week). Registers 05h, 06h, and 07h contain the Date (day of month), Month and Years. The ninth clock register is the Control Register (this is described in the Clock Calibration section). Bit D7 of Register 01h contains the STOP Bit (ST). Setting this bit to a '1' will cause the oscillator to stop. If the device is expected to spend a significant amount of time on the shelf, the oscillator may be stopped to reduce current drain. When reset to a '0' the oscillator restarts within one second.

The eight Clock Registers may be read one byte at a time, or in a sequential block. The Control Register (Address location 08h) may be accessed independently. Provision has been made to assure that a clock update does not occur while any of the eight clock addresses are being read. If a clock address is being read, an update of the clock registers will be halted. This will prevent a transition of data during the READ.

### Power-down Time-Stamp

When a power failure occurs, the Halt Update Bit (HT) will automatically be set to a '1.' This will prevent the clock from updating the clock registers, and will allow the user to read the exact time of the power-down event. Resetting the HT Bit to a '0' will allow the clock to update the clock registers with the current time.

### TIMEKEEPER® Registers

The M41ST95Y/W offers 20 internal registers which contain Clock, Alarm, Watchdog, Flag, Square Wave and Control data (see [Table 4., page 16](#)). These registers are memory locations which contain external (user accessible) and internal copies of the data (usually referred to as BiPORT™ TIMEKEEPER cells). The external copies are independent of internal functions except that they are updated periodically by the simultaneous transfer of the incremented internal copy. The internal divider (or clock) chain will be reset upon the completion of a WRITE to any clock address.

The system-to-user transfer of clock data will be halted whenever the clock addresses (00h to 07h) are being written. The update will resume either due to a deselect condition or when the pointer increments to a non-clock or RAM address.

TIMEKEEPER and Alarm Registers store data in BCD. Control, Watchdog and Square Wave Registers store data in Binary format.

Table 4. TIMEKEEPER® Register Map

Addr									Function/Range BCD Format	
	D7	D6	D5	D4	D3	D2	D1	D0		
00h	0.1 Seconds				0.01 Seconds				10ths/100ths of Seconds	00-99
01h	ST	10 Seconds			Seconds				Seconds	00-59
02h	0	10 Minutes			Minutes				Minutes	00-59
03h	CEB	CB	10 Hours		Hours (24 Hour Format)				Century/Hours	0-1/00-23
04h	TR	0	0	0	0	Day of Week			Day	01-7
05h	0	0	10 Date		Date: Day of Month				Date	01-31
06h	0	0	0	10M	Month				Month	01-12
07h	10 Years				Year				Year	00-99
08h	OUT	FT	S	Calibration					Control	
09h	WDS	BMB4	BMB3	BMB2	BMB1	BMB0	RB1	RB0	Watchdog	
0Ah	AFE	SQWE	ABE	AI 10M	Alarm Month				AI Month	01-12
0Bh	RPT4	RPT5	AI 10 Date		Alarm Date				AI Date	01-31
0Ch	RPT3	HT	AI 10 Hour		Alarm Hour				AI Hour	00-23
0Dh	RPT2	Alarm 10 Minutes			Alarm Minutes				AI Min	00-59
0Eh	RPT1	Alarm 10 Seconds			Alarm Seconds				AI Sec	00-59
0Fh	WDF	AF	0	BL	0	0	0	0	Flags	
10h	0	0	0	0	0	0	0	0	Reserved	
11h	0	0	0	0	0	0	0	0	Reserved	
12h	0	0	0	0	0	0	0	0	Reserved	
13h	RS3	RS2	RS1	RS0	0	0	0	0	SQW	

Keys: S = Sign Bit

FT = Frequency Test Bit

ST = Stop Bit

0 = Must be set to '0'

BL = Battery Low Flag (Read only)

BMB0-BMB4 = Watchdog Multiplier Bits

CEB = Century Enable Bit

CB = Century Bit

OUT = Output level

AFE = Alarm Flag Enable Flag

RB0-RB1 = Watchdog Resolution Bits

WDS = Watchdog Steering Bit

ABE = Alarm in Battery Back-Up Mode Enable Bit

RPT1-RPT5 = Alarm Repeat Mode Bits

WDF = Watchdog flag (Read only)

AF = Alarm flag (Read only)

SQWE = Square Wave Enable

RS0-RS3 = SQW Frequency

HT = Halt Update Bit

TR = tREC Bit



## Calibrating the Clock

The M41ST95Y/W is driven by a quartz-controlled oscillator with a nominal frequency of 32,768Hz. Uncalibrated clock accuracy will not exceed  $\pm 35$  ppm (parts per million) oscillator frequency error at 25°C, which equates to about  $\pm 1.53$  minutes per month. When the Calibration circuit is properly employed, accuracy improves to better than  $\pm 2$  ppm at 25°C.

The oscillation rate of crystals changes with temperature (see [Figure 18., page 24](#)). Therefore, the M41ST95Y/W design employs periodic counter correction. The calibration circuit adds or subtracts counts from the oscillator divider circuit at the divide by 256 stage, as shown in [Figure 19., page 24](#). The number of times pulses are blanked (subtracted, negative calibration) or split (added, positive calibration) depends upon the value loaded into the five Calibration Bits found in the Control Register. Adding counts speeds the clock up, subtracting counts slows the clock down.

The Calibration Bits occupy the five lower order bits (D4-D0) in the Control Register (8h). These bits can be set to represent any value between 0 and 31 in binary form. Bit D5 is a Sign Bit; '1' indicates positive calibration, '0' indicates negative calibration. Calibration occurs within a 64 minute cycle. The first 62 minutes in the cycle may, once per minute, have one second either shortened by 128 or lengthened by 256 oscillator cycles. If a binary '1' is loaded into the register, only the first 2 minutes in the 64 minute cycle will be modified; if a binary 6 is loaded, the first 12 will be affected, and so on.

Therefore, each calibration step has the effect of adding 512 or subtracting 256 oscillator cycles for every 125,829,120 actual oscillator cycles, that is +4.068 or -2.034 ppm of adjustment per calibration step in the calibration register. Assuming that the oscillator is running at exactly 32,768Hz, each of the 31 increments in the Calibration byte would represent +10.7 or -5.35 seconds per month which corresponds to a total range of +5.5 or -2.75 minutes per month.

Two methods are available for ascertaining how much calibration a given M41ST95Y/W may require.

The first involves setting the clock, letting it run for a month and comparing it to a known accurate reference and recording deviation over a fixed period of time. Calibration values, including the number of seconds lost or gained in a given period, can be found in Application Note AN934: TIMEKEEPER CALIBRATION. This allows the designer to give the end user the ability to calibrate the clock as the environment requires, even if the final product is packaged in a non-user serviceable enclosure.

The designer could provide a simple utility that accesses the Calibration Byte.

The second approach is better suited to a manufacturing environment, and involves the use of the  $\overline{\text{IRQ}}/\text{FT}/\text{OUT}$  pin. The pin will toggle at 512Hz, when the Stop Bit (ST, D7 of 1h) is '0,' the Frequency Test Bit (FT, D6 of 8h) is '1,' the Alarm Flag Enable Bit (AFE, D7 of Ah) is '0,' and the Watchdog Steering Bit (WDS, D7 of 9h) is '1' or the Watchdog Register (9h = 0) is reset.

Any deviation from 512Hz indicates the degree and direction of oscillator frequency shift at the test temperature. For example, a reading of 512.010124Hz would indicate a +20 ppm oscillator frequency error, requiring a -10 (XX001010) to be loaded into the Calibration Byte for correction.

**Note:** Setting or changing the Calibration Byte does not affect the Frequency Test output frequency.

The  $\overline{\text{IRQ}}/\text{FT}/\text{OUT}$  pin is an open drain output which requires a pull-up resistor for proper operation. A 500 to 10k $\Omega$  resistor is recommended in order to control the rise time. The FT Bit is cleared on power-down.

## Setting Alarm Clock Registers

Address locations 0Ah-0Eh contain the alarm settings. The alarm can be configured to go off at a prescribed time on a specific month, date, hour, minute, or second, or repeat every year, month, day, hour, minute, or second. It can also be programmed to go off while the M41ST95Y/W is in the battery back-up to serve as a system wake-up call.

Bits RPT5-RPT1 put the alarm in the repeat mode of operation. [Table 5., page 18](#) shows the possible configurations. Codes not listed in the table default to the once per second mode to quickly alert the user of an incorrect alarm setting.

When the clock information matches the alarm clock settings based on the match criteria defined by RPT5-RPT1, the AF (Alarm Flag) is set. If AFE (Alarm Flag Enable) is also set, the alarm condition activates the  $\overline{\text{IRQ}}/\text{FT}/\text{OUT}$  pin.

**Note:** If the address pointer is allowed to increment to the Flag Register address, an alarm condition will not cause the Interrupt/Flag to occur until the address pointer is moved to a different address.

It should also be noted that if the last address written is the "Alarm Seconds," the address pointer will increment to the Flag address, causing this situation to occur.

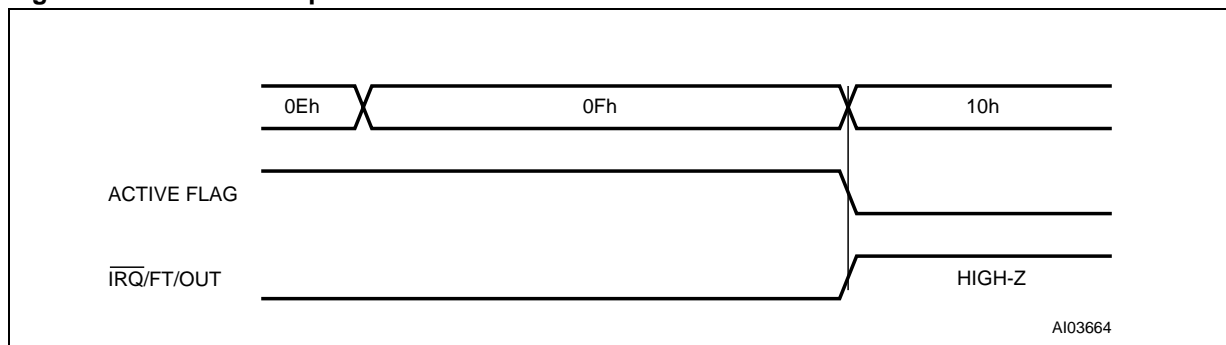
## M41ST95Y\*, M41ST95W

To disable the alarm, write '0' to the Alarm Date Register and to RPT1-5. The  $\overline{\text{IRQ/FT/OUT}}$  output is cleared by a READ to the Flags Register as shown in Figure 14. A subsequent READ of the Flags Register is necessary to see that the value of the Alarm Flag has been reset to '0.'

The  $\overline{\text{IRQ/FT/OUT}}$  pin can also be activated in the battery back-up mode. The  $\overline{\text{IRQ/FT/OUT}}$  will go low if an alarm occurs and both ABE (Alarm in Battery Back-up Mode Enable) and AFE are set.

The ABE and AFE Bits are reset during power-up, therefore an alarm generated during power-up will only set AF. The user can read the Flag Register at system boot-up to determine if an alarm was generated while the M41ST95Y/W was in the de-select mode during power-up. Figure 15., page 19 illustrates the back-up mode alarm timing.

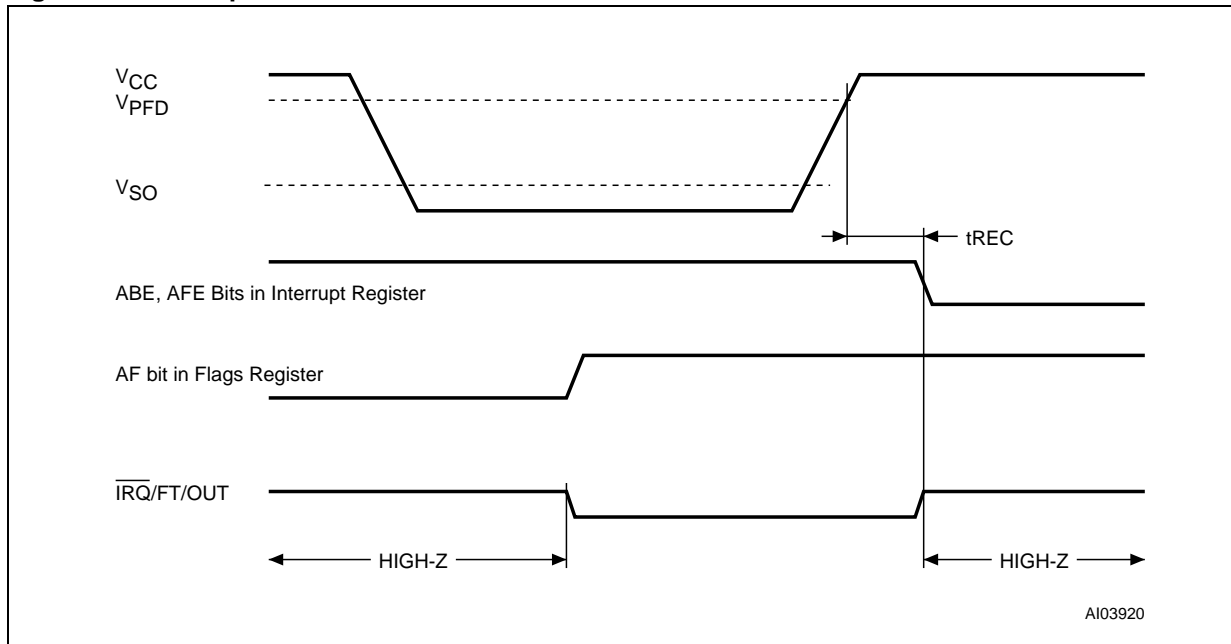
**Figure 14. Alarm Interrupt Reset Waveform**



**Table 5. Alarm Repeat Mode**

RPT5	RPT4	RPT3	RPT2	RPT1	Alarm Setting
1	1	1	1	1	Once per Second
1	1	1	1	0	Once per Minute
1	1	1	0	0	Once per Hour
1	1	0	0	0	Once per Day
1	0	0	0	0	Once per Month
0	0	0	0	0	Once per Year

Figure 15. Back-up Mode Alarm Waveforms



### Watchdog Timer

The watchdog timer can be used to detect an out-of-control microprocessor. The user programs the watchdog timer by setting the desired amount of time-out into the Watchdog Register, address 09h. Bits BMB4-BMB0 store a binary multiplier and the two lower order bits RB1-RB0 select the resolution, where 00 =  $\frac{1}{16}$  second, 01 =  $\frac{1}{4}$  second, 10 = 1 second, and 11 = 4 seconds. The amount of time-out is then determined to be the multiplication of the five-bit multiplier value with the resolution. (For example: writing 00001110 in the Watchdog Register =  $3 \cdot 1$  or 3 seconds).

**Note:** Accuracy of timer is within  $\pm$  the selected resolution.

If the processor does not reset the timer within the specified period, the M41ST95Y/W sets the WDF (Watchdog Flag) and generates a watchdog interrupt or a microprocessor reset. WDF is reset by reading the Flags Register (0Fh).

The most significant bit of the Watchdog Register is the Watchdog Steering Bit (WDS). When set to a '0,' the watchdog will activate the  $\overline{\text{IRQ}}/\text{FT}/\text{OUT}$  pin when timed-out. When WDS is set to a '1,' the watchdog will output a negative pulse on the RST pin for  $t_{\text{REC}}$ .

The Watchdog register and the AFE, ABE, SQWE, and FT Bits will reset to a '0' at the end of a Watchdog time-out when the WDS Bit is set to a '1.'

The watchdog timer can be reset by two methods:

1. a transition (high-to-low or low-to-high) can be applied to the Watchdog Input pin (WDI), or
2. the microprocessor can perform a WRITE of the Watchdog Register.

The time-out period then starts over. The WDI pin should be tied to  $V_{\text{SS}}$  if not used. In order to perform a software reset of the watchdog timer, the original time-out period can be written into the Watchdog Register, effectively restarting the count-down cycle.

Should the watchdog timer time-out, and the WDS Bit is programmed to output an interrupt, a value of 00h needs to be written to the Watchdog Register in order to clear the  $\overline{\text{IRQ}}/\text{FT}/\text{OUT}$  pin. This will also disable the watchdog function until it is again programmed correctly. A READ of the Flags Register will reset the Watchdog Flag (Bit D7; Register 0Fh).

The watchdog function is automatically disabled upon power-up and the Watchdog Register is cleared. If the watchdog function is set to output to the  $\overline{\text{IRQ}}/\text{FT}/\text{OUT}$  pin and the Frequency Test (FT) function is activated, the watchdog function prevails and the Frequency Test function is denied.

## M41ST95Y\*, M41ST95W

### Square Wave Output

The M41ST95Y/W offers the user a programmable square wave function which is output on the SQW pin. RS3-RS0 bits located in 13h establish the square wave output frequency. These frequencies are listed in Table 6. Once the selection

of the SQW frequency has been completed, the SQW pin can be turned on and off under software control with the Square Wave Enable Bit (SQWE) located in Register 0Ah.

**Table 6. Square Wave Output Frequency**

Square Wave Bits				Square Wave	
RS3	RS2	RS1	RS0	Frequency	Units
0	0	0	0	None	–
0	0	0	1	32.768	kHz
0	0	1	0	8.192	kHz
0	0	1	1	4.096	kHz
0	1	0	0	2.048	kHz
0	1	0	1	1.024	kHz
0	1	1	0	512	Hz
0	1	1	1	256	Hz
1	0	0	0	128	Hz
1	0	0	1	64	Hz
1	0	1	0	32	Hz
1	0	1	1	16	Hz
1	1	0	0	8	Hz
1	1	0	1	4	Hz
1	1	1	0	2	Hz
1	1	1	1	1	Hz

### Full-time F<sub>32k</sub> Square Wave Output (Available only in 28-pin, 300mil SOIC (MX) package).

The M41ST95Y/W offers the user a special 32kHz square wave function which is always output on the F<sub>32k</sub> pin (Pin 21) as long as V<sub>CC</sub> ≥ V<sub>SO</sub>, and the oscillator is running (ST Bit = '0'). This function is available within four seconds of initial power-up

and can only be disabled by setting the ST Bit to '1,' or while the device is in back-up. If not used, the F<sub>32k</sub> pin should be disconnected and allowed to float.

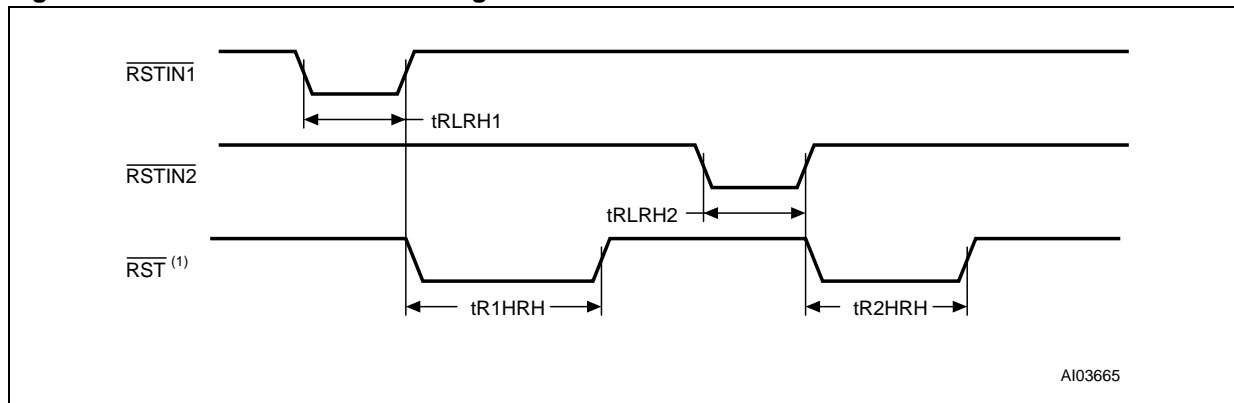
**Power-on Reset**

The M41ST95Y/W continuously monitors  $V_{CC}$ . When  $V_{CC}$  falls to the power fail detect trip point, the  $\overline{RST}$  pulls low (open drain) and remains low on power-up for  $t_{REC}$  after  $V_{CC}$  passes  $V_{PFD}$  (max). The  $\overline{RST}$  pin is an open drain output and an appropriate pull-up resistor should be chosen to control rise time.

**Reset Input ( $\overline{RSTIN1}$  and  $\overline{RSTIN2}$ )**

The M41ST95Y/W provides two independent inputs which can generate an output reset. The duration and function of these resets is identical to a reset generated by a power cycle. Table 7 and Figure 16 illustrate the AC reset characteristics of this function. Pulses shorter than  $t_{RLRH1}$  and  $t_{RLRH2}$  will not generate a reset condition.  $\overline{RSTIN1}$  and  $\overline{RSTIN2}$  are each internally pulled up to  $V_{CC}$  through a 100k $\Omega$  resistor.

**Figure 16.  $\overline{RSTIN1}$  and  $\overline{RSTIN2}$  Timing Waveforms**



Note: 1. Open Drain Output

**Table 7. Reset AC Characteristics**

Symbol	Parameter <sup>(1)</sup>	Min	Max	Unit
$t_{RLRH1}$ <sup>(2)</sup>	$\overline{RSTIN1}$ Low to $\overline{RSTIN1}$ High	200		ns
$t_{RLRH2}$ <sup>(3)</sup>	$\overline{RSTIN2}$ Low to $\overline{RSTIN2}$ High	100		ms
$t_{R1HRH}$ <sup>(4)</sup>	$\overline{RSTIN1}$ High to $\overline{RST}$ High	96	98	ms
$t_{R2HRH}$ <sup>(4,5)</sup>	$\overline{RSTIN2}$ High to $\overline{RST}$ High	96	98	ms

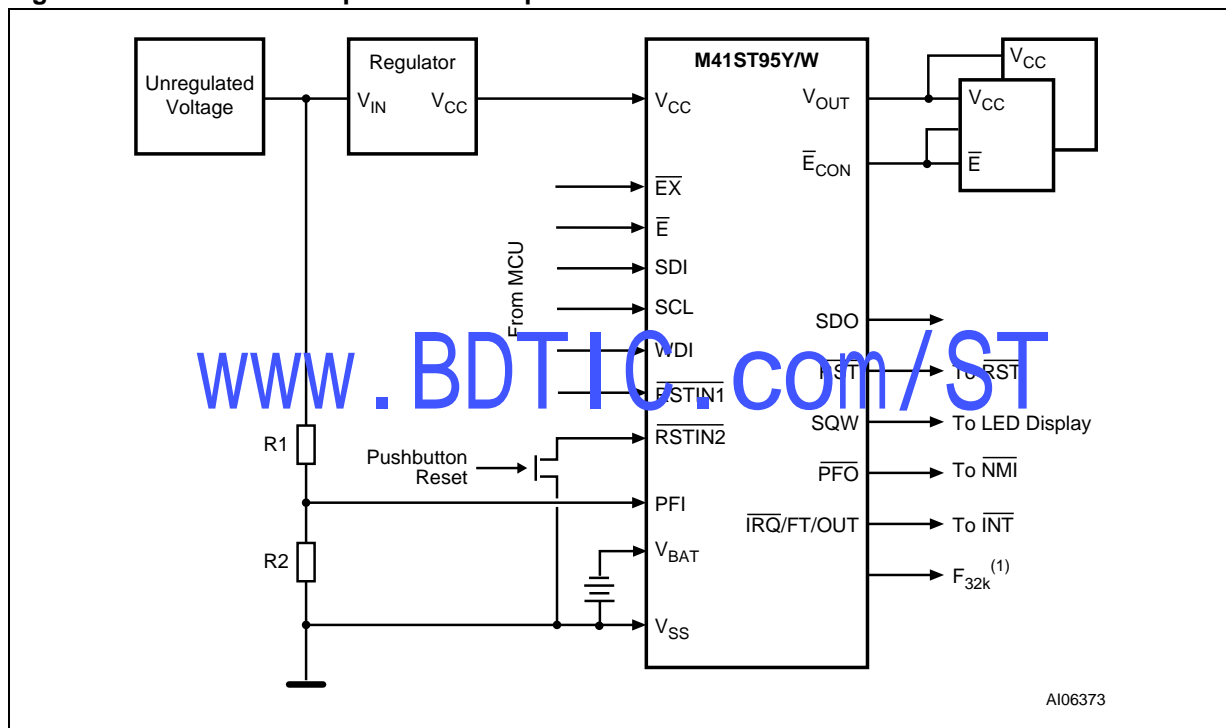
Note: 1. Valid for Ambient Operating Temperature:  $T_A = -40$  to  $85^\circ\text{C}$ ;  $V_{CC} = 4.5$  to  $5.5\text{V}$  or  $2.7$  to  $3.6\text{V}$  (except where noted).  
 2. Pulse width less than 50ns will result in no RESET (for noise immunity).  
 3. Pulse width less than 20ms will result in no RESET (for noise immunity).  
 4. Programmable (see Table 8., page 23)  
 5. After crystal oscillator has started

**Power-fail INPUT/OUTPUT**

The Power-Fail Input (PFI) is compared to an internal reference voltage (1.25V). If PFI is less than the power-fail threshold ( $V_{PFI}$ ), the Power-Fail Output ( $\overline{PFO}$ ) will go low. This function is intended for use as an under-voltage detector to signal a failing power supply. Typically PFI is connected through an external voltage divider (see Figure 17) to either the unregulated DC input (if it is available) or the regulated output of the  $V_{CC}$  regulator. The voltage divider can be set up such that the voltage at PFI falls below  $V_{PFI}$  several milliseconds before the regulated  $V_{CC}$  input to the M41ST95Y/W or the microprocessor drops below the minimum operating voltage.

During battery back-up, the power-fail comparator turns off and  $\overline{PFO}$  goes (or remains) low. This occurs after  $V_{CC}$  drops below  $V_{PFD(min)}$ . When power returns,  $\overline{PFO}$  is forced high, irrespective of  $V_{PFI}$  for the write protect time ( $t_{REC}$ ), which is the time from  $V_{PFD(max)}$  until the inputs are recognized. At the end of this time, the power-fail comparator is enabled and  $\overline{PFO}$  follows PFI. If the comparator is unused, PFI should be connected to  $V_{SS}$  and  $\overline{PFO}$  left unconnected.

**Figure 17. Power-Fail Comparator Hookup**



Note: 1. Available only in 28-pin, 300mil SOIC (MX) package.

### Century Bit

Bits D7 and D6 of Clock Register 03h contain the CENTURY ENABLE Bit (CEB) and the CENTURY Bit (CB). Setting CEB to a '1' will cause CB to toggle, either from a '0' to '1' or from '1' to '0' at the turn of the century (depending upon its initial state). If CEB is set to a '0,' CB will not toggle.

### Output Driver Pin

When the FT Bit, AFE Bit and Watchdog Register are not set, the  $\overline{\text{IRQ/FT/OUT}}$  pin becomes an output driver that reflects the contents of D7 of the Control Register. In other words, when D7 (OUT Bit) and D6 (FT Bit) of address location 08h are a '0,' then the  $\overline{\text{IRQ/FT/OUT}}$  pin will be driven low.

**Note:** The  $\overline{\text{IRQ/FT/OUT}}$  pin is an open drain which requires an external pull-up resistor.

### Battery Low Warning

The M41ST95Y/W automatically performs battery voltage monitoring upon power-up and at factory-programmed time intervals of approximately 24 hours. The Battery Low (BL) Bit, Bit D4 of Flags Register 0Fh, will be asserted if the battery voltage is found to be less than approximately 2.5V. The BL Bit will remain asserted until completion of battery replacement and subsequent battery low monitoring tests, either during the next power-up sequence or the next scheduled 24-hour interval.

If a battery low is generated during a power-up sequence, this indicates that the battery is below approximately 2.5 volts and may not be able to maintain data integrity in the SRAM. Data should be considered suspect and verified as correct. A fresh battery should be installed.

If a battery low indication is generated during the 24-hour interval check, this indicates that the battery is near end of life. However, data is not compromised due to the fact that a nominal  $V_{CC}$  is supplied. In order to insure data integrity during subsequent periods of battery back-up mode, the battery should be replaced. The SNAPHAT<sup>®</sup> top may be replaced while  $V_{CC}$  applied to the device.

The M41ST95Y/W only monitors the battery when a nominal  $V_{CC}$  is applied to the device. Thus applications which require extensive durations in the battery back-up mode should be powered-up periodically (at least once every few months) in order for this technique to be beneficial. Additionally, if a battery low is indicated, data integrity should be verified upon power-up via a checksum or other technique.

### $t_{REC}$ Bit

Bit D7 of Clock Register 04h contains the  $t_{REC}$  Bit (TR).  $t_{REC}$  refers to the automatic continuation of the deselect time after  $V_{CC}$  reaches  $V_{PFD}$ . This allows for a voltage setting time before WRITES may again be performed to the device after a power-down condition. The  $t_{REC}$  Bit will allow the user to set the length of this deselect time as defined by Table 8.

### Preferred Power-on Defaults

Upon initial application of power to the device, the following register bits are set to a '0' state: Watchdog Register, TR, FT, AFE, ABE, and SQWE. The following bits are set to a '1' state: OUT and HT (see Table 9).

**Table 8.  $t_{REC}$  Definitions**

$t_{REC}$ Bit (TR)	STOP Bit (ST)	$t_{REC}$ Time		Units
		Min	Max	
0	0	96	98 <sup>(1)</sup>	ms
0	1	40	200	ms
1	X	50	2000	$\mu$ s

Note: 1. Default Setting; after oscillator has started

**Table 9. Default Values**

Condition	TR	ST	HT	Out	FT	AFE	ABE	SQWE	WATCHDOG Register <sup>(1)</sup>
Initial Power-up (Battery Attach for SNAPHAT) <sup>(2)</sup>	0	0	1	1	0	0	0	0	0
Subsequent power-up (with battery back-up) <sup>(3)</sup>	UC	UC	1	UC	0	0	0	0	0

Note: 1. WDS, BMB0-BMB4, RB0, RB1.

2. State of other control bits undefined.

3. UC = Unchanged.



Figure 18. Crystal Accuracy Across Temperature

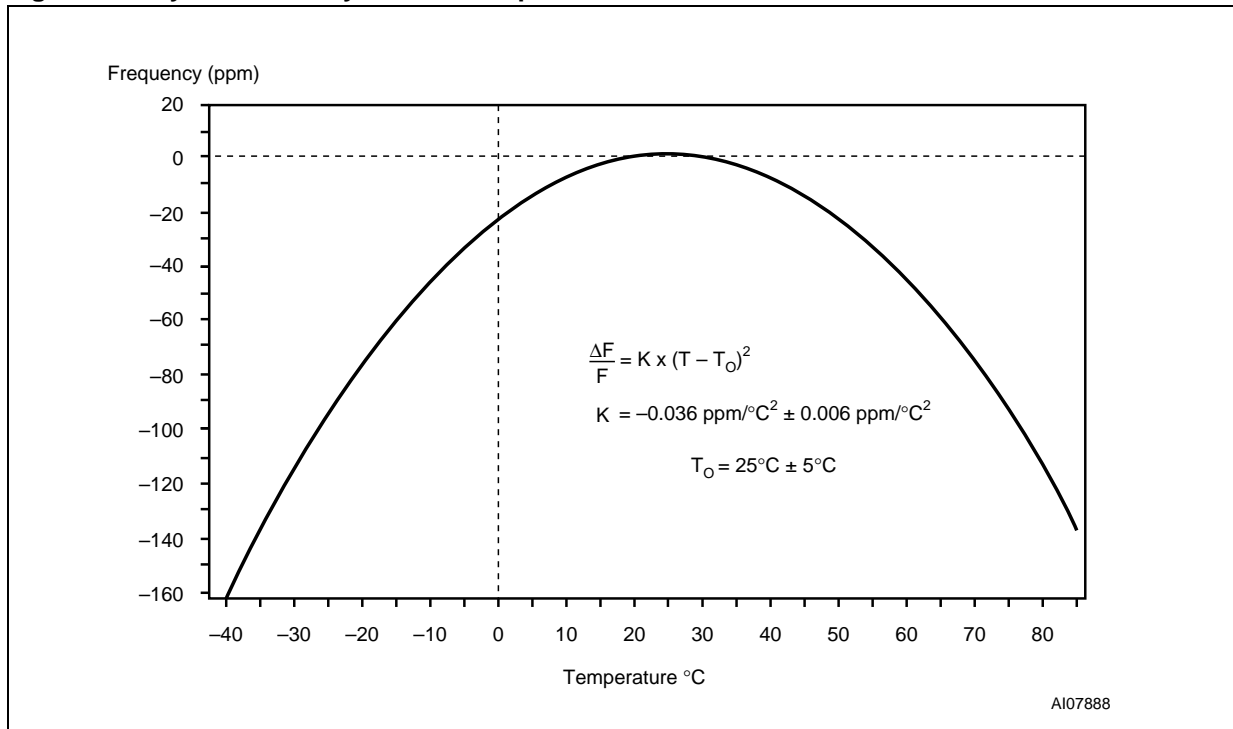
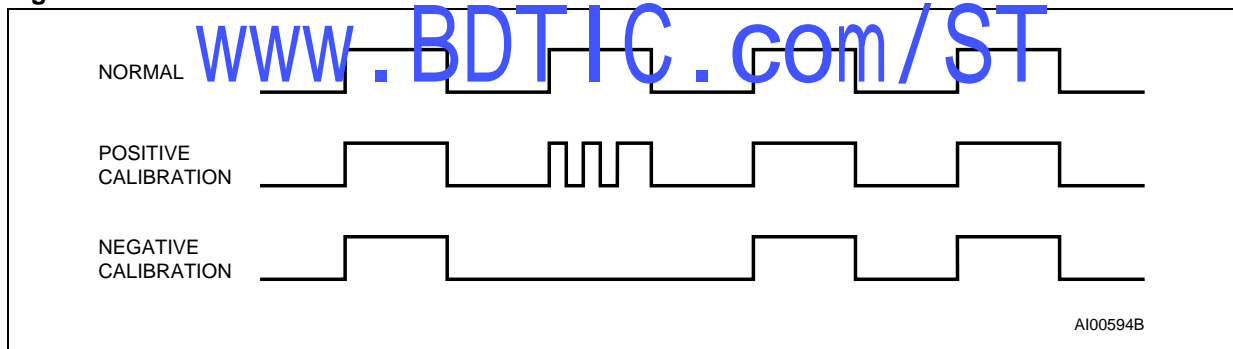


Figure 19. Calibration Waveform





## MAXIMUM RATING

Stressing the device above the rating listed in the “Absolute Maximum Ratings” table may cause permanent damage to the device. These are stress ratings only and operation of the device at these or any other conditions above those indicated in the Operating sections of this specification is

not implied. Exposure to Absolute Maximum Rating conditions for extended periods may affect device reliability. Refer also to the STMicroelectronics SURE Program and other relevant quality documents.

**Table 10. Absolute Maximum Ratings**

Symbol	Parameter	Value	Unit	
T <sub>STG</sub>	Storage Temperature (V <sub>CC</sub> Off, Oscillator Off)	–55 to 125	°C	
V <sub>CC</sub>	Supply Voltage	M41ST95Y	–0.3 to 7	V
		M41ST95W	–0.3 to 4.6	V
T <sub>SLD</sub>	Lead Solder Temperature for 10 seconds	Lead-free lead finish <sup>(1)</sup>	260	°C
		Standard (SnPb) lead finish <sup>(2,3)</sup>	240	°C
T <sub>SLD</sub> <sup>(1,2)</sup>	Lead Solder Temperature for 10 seconds	260	°C	
V <sub>IO</sub>	Input or Output Voltage	–0.3 to V <sub>CC</sub> +0.3	V	
I <sub>O</sub>	Output Current	20	mA	
P <sub>D</sub>	Power Dissipation	1	W	

Note: 1. For SOH28 package, Lead-free (Pb-free) lead finish: Reflow at peak temperature of 260°C (total thermal budget not to exceed 245°C for greater than 30 seconds).  
 2. For SOH28 package, standard (SnPb) lead finish: Reflow at peak temperature of 235°C (total thermal budget not to exceed 180°C for between 30 to 60 seconds).  
 3. The SOX28 package has Lead-free (Pb-free) lead finish, but cannot be exposed to peak reflow temperature in excess of 240°C (use same reflow profile as standard (SnPb) lead finish).

**CAUTION:** Negative undershoots below –0.3V are not allowed on any pin while in the Battery Back-up mode.

**CAUTION:** Do NOT wave solder SOIC to avoid damaging SNAPHAT sockets.

### DC AND AC PARAMETERS

This section summarizes the operating and measurement conditions, as well as the DC and AC characteristics of the device. The parameters in the following DC and AC Characteristic tables are derived from tests performed under the Measure-

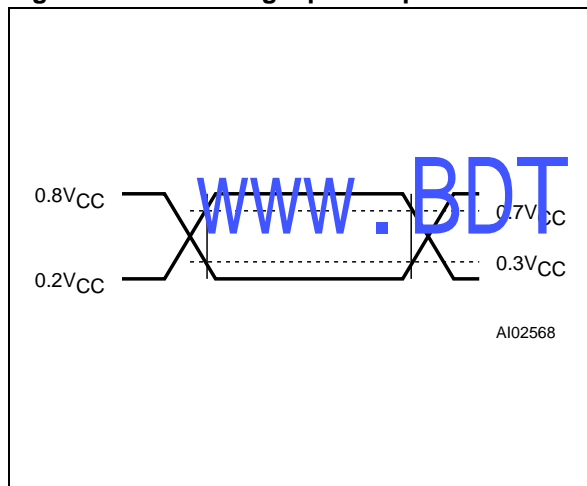
ment Conditions listed in the relevant tables. Designers should check that the operating conditions in their projects match the measurement conditions when using the quoted parameters.

**Table 11. DC and AC Measurement Conditions**

Parameter	M41ST95Y	M41ST95W
V <sub>CC</sub> Supply Voltage	4.5 to 5.5V	2.7 to 3.6V
Ambient Operating Temperature	-40 to 85°C	-40 to 85°C
Load Capacitance (C <sub>L</sub> )	100pF	50pF
Input Rise and Fall Times	≤ 50ns	≤ 50ns
Input Pulse Voltages	0.2 to 0.8V <sub>CC</sub>	0.2 to 0.8V <sub>CC</sub>
Input and Output Timing Ref. Voltages	0.3 to 0.7V <sub>CC</sub>	0.3 to 0.7V <sub>CC</sub>

Note: Output Hi-Z is defined as the point where data is no longer driven.

**Figure 20. AC Testing Input/Output Waveforms**



**Table 12. Capacitance**

Symbol	Parameter <sup>(1,2)</sup>	Min	Max	Unit
C <sub>IN</sub>	Input Capacitance		7	pF
C <sub>OUT</sub> <sup>(3)</sup>	Output Capacitance		10	pF
t <sub>LP</sub>	Low-pass filter input time constant (SDI and SCL)		50	ns

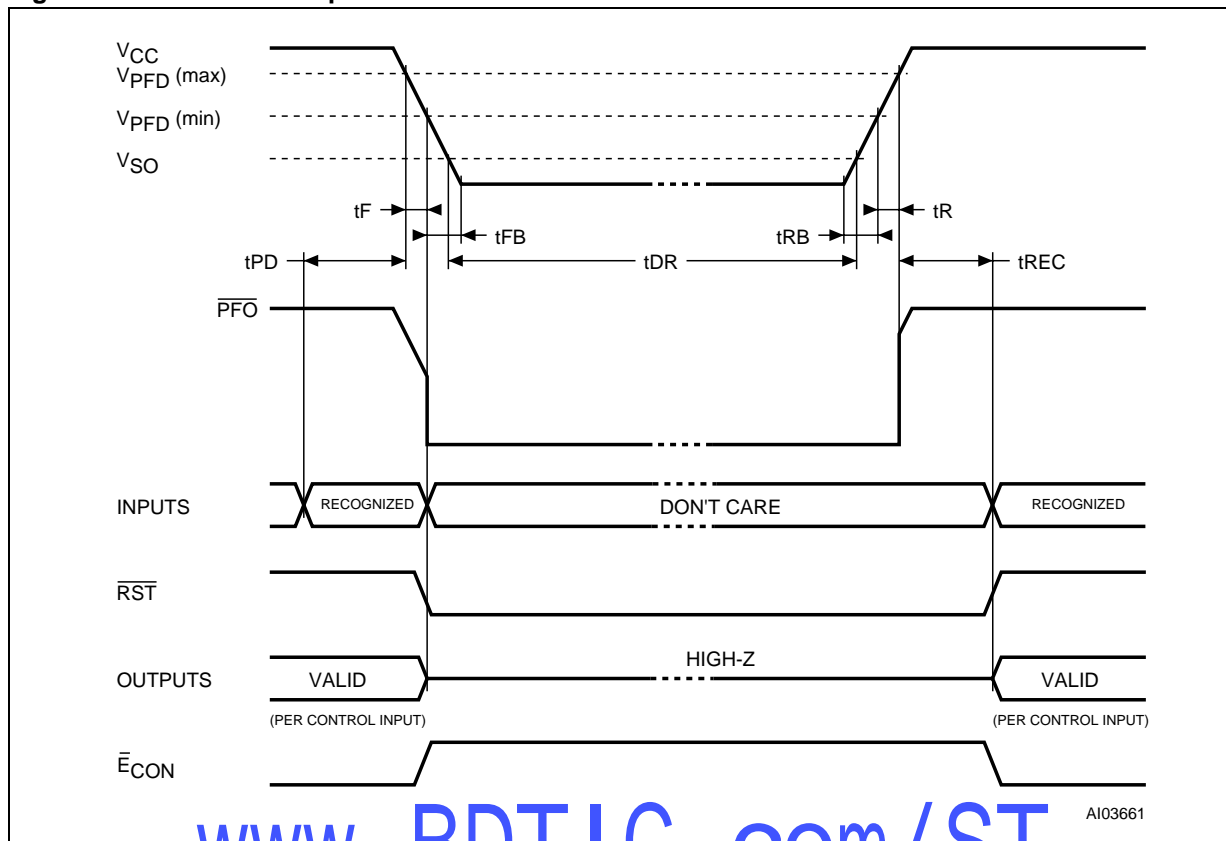
Note: 1. Effective capacitance measured with power supply at 5V; sampled only, not 100% tested.  
 2. At 25°C, f = 1MHz.  
 3. Outputs are deselected.

Table 13. DC Characteristics

Sym	Parameter	Test Condition <sup>(1)</sup>	M41ST95Y			M41ST95W			Unit
			Min	Typ	Max	Min	Typ	Max	
I <sub>BAT</sub> <sup>(2)</sup>	Battery Current OSC ON	T <sub>A</sub> = 25°C, V <sub>CC</sub> = 0V, V <sub>BAT</sub> = 3V		400	550		400	550	nA
	Battery Current OSC OFF			50		50		nA	
I <sub>CC1</sub>	Supply Current	f = 2MHz			2		2	mA	
I <sub>CC2</sub>	Supply Current (Standby)	SCL, SDI = V <sub>CC</sub> - 0.3V			1.4		1.4	mA	
I <sub>LI</sub> <sup>(3)</sup>	Input Leakage Current	0V ≤ V <sub>IN</sub> ≤ V <sub>CC</sub>			±1		±1	µA	
	Input Leakage Current (PFI)		-25	2	25	-25	2	25	nA
I <sub>LO</sub> <sup>(4)</sup>	Output Leakage Current	0V ≤ V <sub>IN</sub> ≤ V <sub>CC</sub>			±1		±1	µA	
I <sub>OUT1</sub> <sup>(5)</sup>	V <sub>OUT</sub> Current (Active)	V <sub>OUT1</sub> > V <sub>CC</sub> - 0.3V			175		100	mA	
I <sub>OUT2</sub>	V <sub>OUT</sub> Current (Battery Back-up)	V <sub>OUT2</sub> > V <sub>BAT</sub> - 0.3V			100		100	µA	
V <sub>IH</sub>	Input High Voltage		0.7V <sub>CC</sub>		V <sub>CC</sub> + 0.3	0.7V <sub>CC</sub>	V <sub>CC</sub> + 0.3	V	
V <sub>IL</sub>	Input Low Voltage		-0.3		0.3V <sub>CC</sub>	-0.3	0.3V <sub>CC</sub>	V	
V <sub>BAT</sub>	Battery Voltage		2.5	3.0	3.5 <sup>(6)</sup>	2.5	3.0	3.5 <sup>(6)</sup>	V
V <sub>OH</sub>	Output High Voltage <sup>(7)</sup>	I <sub>OH</sub> = -1.0mA	2.4			2.4		V	
	Power Supply Voltage (Open Drain)	$\overline{\text{IRQ}}/\text{FT}/\text{OUT}, \overline{\text{RST}}$			5.5		3.6	V	
V <sub>OHB</sub> <sup>(8)</sup>	V <sub>OH</sub> (Battery Back-up)	I <sub>OUT2</sub> = -1.0µA	2.5	2.9	3.5	2.5	2.9	3.5	V
V <sub>OL</sub>	Output Low Voltage	I <sub>OL</sub> = 3.0mA			0.4		0.4	V	
	Output Low Voltage (Open Drain) <sup>(9)</sup>	I <sub>OL</sub> = 10mA			0.4		0.4	V	
V <sub>PFD</sub>	Power Fail Deselect		4.20	4.40	4.50	2.55	2.60	2.70	V
V <sub>PFI</sub>	PFI Input Threshold	V <sub>CC</sub> = 5V(Y) V <sub>CC</sub> = 3V(W)	1.225	1.250	1.275	1.225	1.250	1.275	V
	PFI Hysteresis	PFI Rising		20	70		20	70	mV
V <sub>SO</sub>	Battery Back-up Switchover			2.5		2.5		V	

- Note: 1. Valid for Ambient Operating Temperature: T<sub>A</sub> = -40 to 85°C; V<sub>CC</sub> = 4.5 to 5.5V or 2.7 to 3.6V (except where noted).  
2. Measured with V<sub>OUT</sub> and  $\overline{\text{ECON}}$  open.  
3.  $\overline{\text{RSTIN1}}$  and  $\overline{\text{RSTIN2}}$  internally pulled-up to V<sub>CC</sub> through 100KΩ resistor. WDI internally pulled-down to V<sub>SS</sub> through 100KΩ resistor.  
4. Outputs Deselected.  
5. External SRAM must match RTC SUPERVISOR chip V<sub>CC</sub> specification.  
6. For rechargeable back-up, V<sub>BAT(max)</sub> may be considered V<sub>CC</sub>.  
7. For PFO, F<sub>32k</sub>, and SQW pins (CMOS).  
8. Conditioned output ( $\overline{\text{ECON}}$ ) can only sustain CMOS leakage current in the battery back-up mode. Higher leakage currents will reduce battery life.  
9. For  $\overline{\text{IRQ}}/\text{FT}/\text{OUT}, \overline{\text{RST}}$  pins (Open Drain); if pulled-up to supply other than V<sub>CC</sub>, this supply must be equal to, or less than 3.0V when V<sub>CC</sub> = 0V (during battery back-up mode).

Figure 21. Power Down/Up Mode AC Waveforms



www.BDTIC.com/ST

AI03661

Table 14. Power Down/Up AC Characteristics

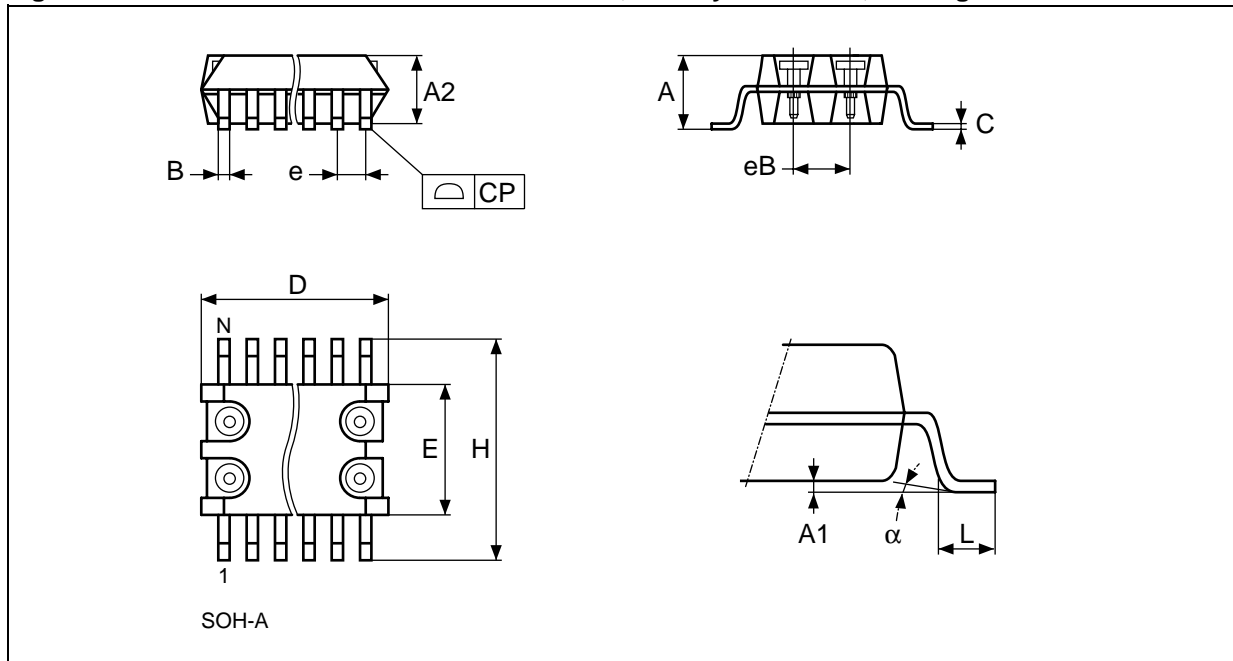
Symbol	Parameter <sup>(1)</sup>	Min	Typ	Max	Unit
t <sub>F</sub> <sup>(2)</sup>	V <sub>PFD</sub> (max) to V <sub>PFD</sub> (min) V <sub>CC</sub> Fall Time	300			μs
t <sub>FB</sub> <sup>(3)</sup>	V <sub>PFD</sub> (min) to V <sub>SS</sub> V <sub>CC</sub> Fall Time	10			μs
t <sub>R</sub>	V <sub>PFD</sub> (min) to V <sub>PFD</sub> (max) V <sub>CC</sub> Rise Time	10			μs
t <sub>RB</sub>	V <sub>SS</sub> to V <sub>PFD</sub> (min) V <sub>CC</sub> Rise Time	1			μs
t <sub>PF</sub>	PFI to PFI Propagation Delay		15	25	μs
t <sub>REC</sub> <sup>(4,5)</sup>	Power up Deselect Time	96		98	ms

- Note: 1. Valid for Ambient Operating Temperature: T<sub>A</sub> = -40 to 85°C; V<sub>CC</sub> = 4.5 to 5.5V or 2.7 to 3.6V (except where noted).  
 2. V<sub>PFD</sub> (max) to V<sub>PFD</sub> (min) fall time of less than t<sub>F</sub> may result in deselection/write protection not occurring until 200μs after V<sub>CC</sub> passes V<sub>PFD</sub> (min).  
 3. V<sub>PFD</sub> (min) to V<sub>SS</sub> fall time of less than t<sub>FB</sub> may cause corruption of RAM data.  
 4. Programmable (see Table 8., page 23)  
 5. After crystal oscillator has started



## PACKAGE MECHANICAL INFORMATION

Figure 22. SOH28 – 28-lead Plastic Small Outline, Battery SNAPHAT, Package Outline



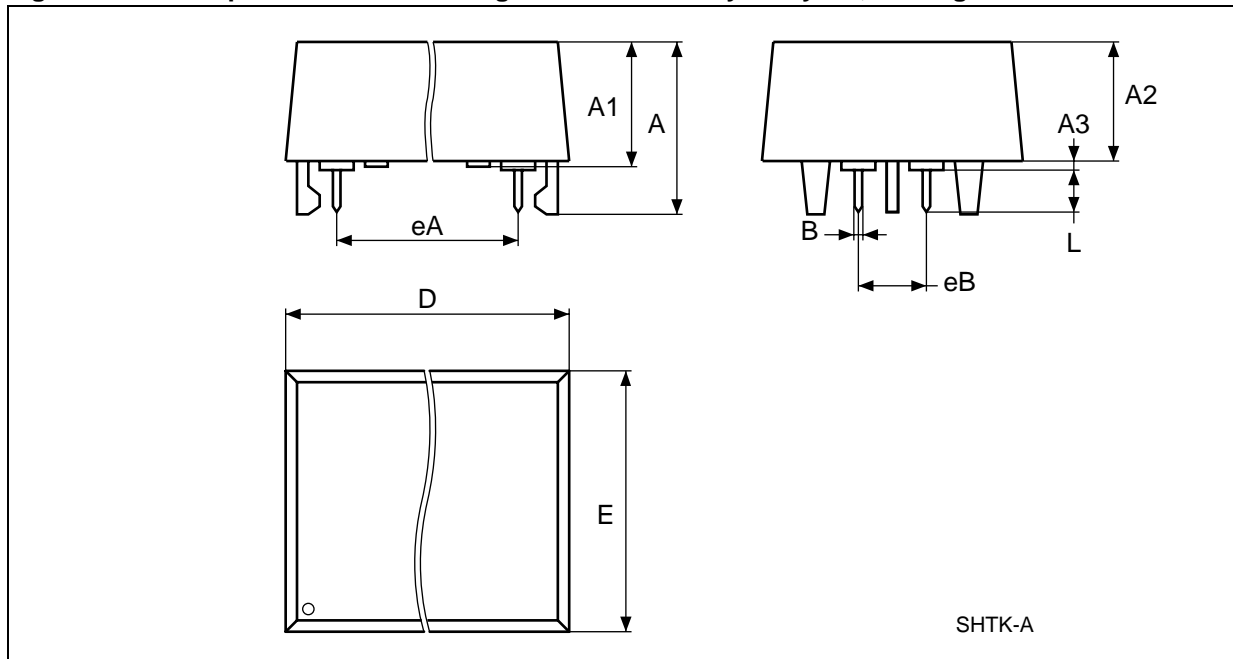
Note: Drawing is not to scale.

Table 15. SOH28 – 28-lead Plastic Small Outline, Battery SNAPHAT, Package Mechanical Data

Symbol	millimeters			inches		
	Typ	Min	Max	Typ	Min	Max
A			3.05			0.120
A1		0.05	0.36		0.002	0.014
A2		2.34	2.69		0.092	0.106
B		0.36	0.51		0.014	0.020
C		0.15	0.32		0.006	0.012
D		17.71	18.49		0.697	0.728
E		8.23	8.89		0.324	0.350
e	1.27	–	–	0.050	–	–
eB		3.20	3.61		0.126	0.142
H		11.51	12.70		0.453	0.500
L		0.41	1.27		0.016	0.050
$\alpha$		0°	8°		0°	8°
N	28			28		
CP			0.10			0.004

**M41ST95Y\*, M41ST95W**

**Figure 23. SH – 4-pin SNAPHAT Housing for 48mAh Battery & Crystal, Package Outline**

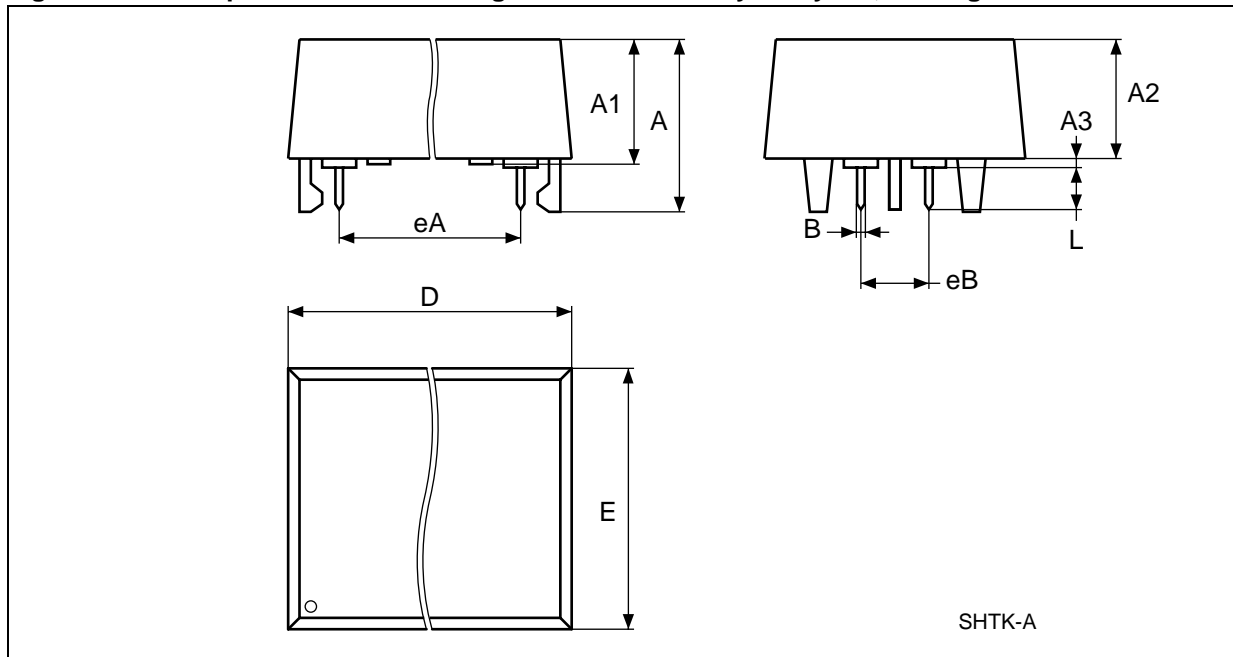


Note: Drawing is not to scale.

**Table 16. SH – 4-pin SNAPHAT Housing for 48mAh Battery & Crystal, Package Mechanical Data**

Symbol	millimeters			inches		
	Typ	Min	Max	Typ	Min	Max
A			9.76			0.3850
A1		6.73	7.24		0.2650	0.2850
A2		6.48	6.99		0.2551	0.2752
A3			0.38			0.0150
B		0.46	0.56		0.0181	0.0220
D		21.21	21.84		0.8350	0.8598
E		14.22	14.99		0.5598	0.5902
eA		15.55	15.95		0.6122	0.6280
eB		3.20	3.61		0.1260	0.1421
L		2.03	2.29		0.0799	0.0902

Figure 24. SH – 4-pin SNAPHAT Housing for 120mAh Battery &amp; Crystal, Package Outline



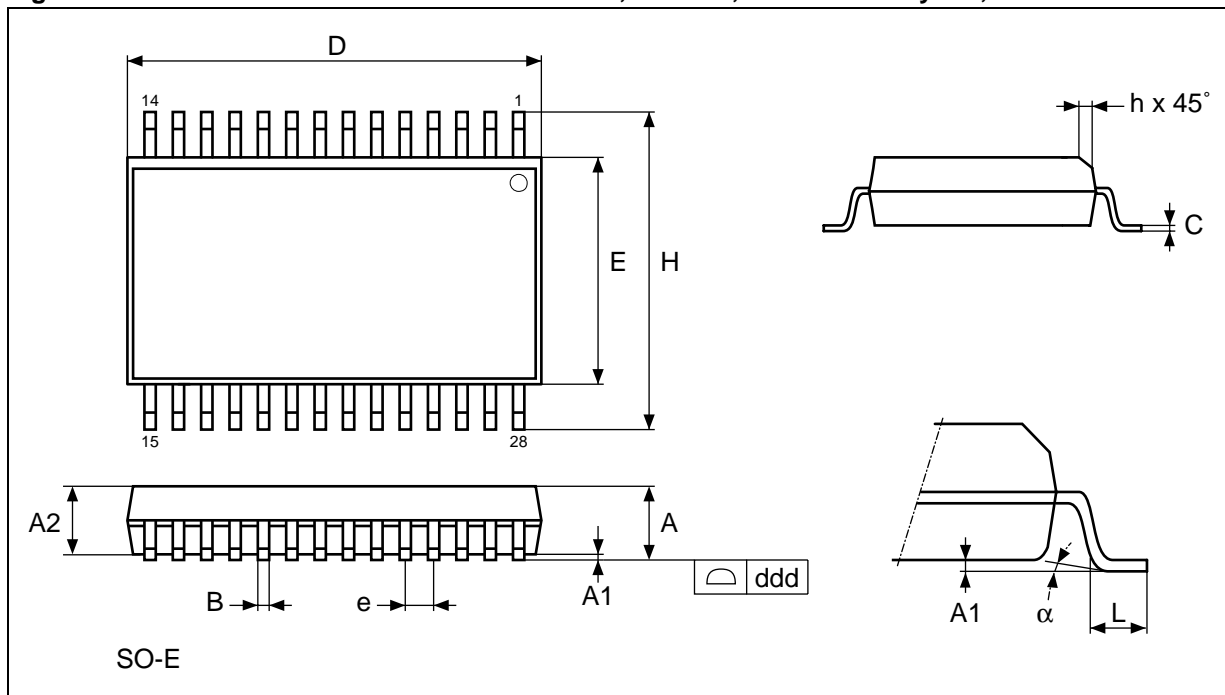
Note: Drawing is not to scale.

Table 17. SH – 4-pin SNAPHAT Housing for 120mAh Battery &amp; Crystal, Package Mech. Data

Symbol	millimeters			inches		
	Typ	Min	Max	Typ	Min	Max
A			10.54			0.4150
A1		6.73	7.24		0.2650	0.2850
A2		6.48	6.99		0.2551	0.2752
A3			0.38			0.0150
B		0.46	0.56		0.0181	0.0220
D		21.21	21.84		0.8350	0.8598
E		14.22	14.99		0.5598	0.5902
eA		15.55	15.95		0.6122	0.6280
eB		3.20	3.61		0.1260	0.1421
L		2.03	2.29		0.0799	0.0902

**M41ST95Y\*, M41ST95W**

**Figure 25. SOX28 – 28-lead Plastic Small Outline, 300mils, Embedded Crystal, Outline**



Note: Drawing is not to scale.

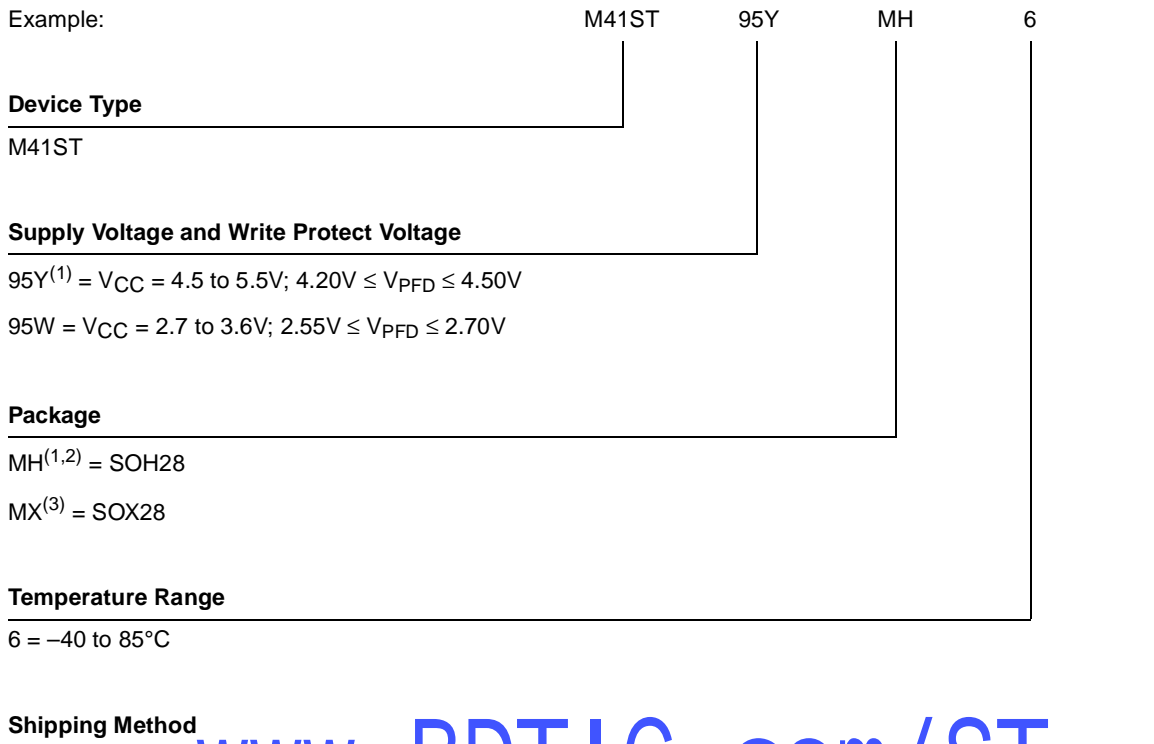
**Table 18. SOX28 – 28-lead Plastic Small, 300mils, Embedded Crystal, Package Mech. Data**

Symbol	millimeters			inches		
	Typ	Min	Max	Typ	Min	Max
A		2.44	2.69		0.096	0.106
A1		0.15	0.31		0.006	0.012
A2		2.29	2.39		0.090	0.094
B		0.41	0.51		0.016	0.020
C		0.20	0.31		0.008	0.012
D		17.91	18.01		0.705	0.709
ddd			0.10			0.004
E		7.57	7.67		0.298	0.302
e	1.27	–	–	0.050	–	–
H		10.16	10.52		0.400	0.414
L		0.51	0.81		0.020	0.032
$\alpha$		0°	8°		0°	8°
N		28			28	



## PART NUMBERING

**Table 19. Ordering Information Scheme**



**For SOH28:**

blank = Tubes (Not for New Design - Use E)

E = Lead-free Package (ECO<sup>®</sup>PACK<sup>®</sup>), Tubes

F = Lead-free Package (ECO<sup>®</sup>PACK<sup>®</sup>), Tape & Reel

TR = Tape & Reel (Not for New Design - Use F)

**For SOX28:**

blank = Tubes

TR = Tape & Reel

Note: 1. Contact Local Sales Office

2. The SOIC package (SOH28) requires the SNAPHAT<sup>®</sup> battery package which is ordered separately under the part number "M4TXX-BR12SH" in plastic tube or "M4TXX-BR12SHTR" in Tape & Reel form (see Table 20).

3. The SOX28 package includes an embedded 32,768Hz crystal.

**Caution:** Do not place the SNAPHAT battery package "M4TXX-BR12SH" in conductive foam as it will drain the lithium button-cell battery.

For other options, or for more information on any aspect of this device, please contact the ST Sales Office nearest you.

**Table 20. SNAPHAT Battery Table**

Part Number	Description	Package
M4T28-BR12SH	Lithium Battery (48mAh) and Crystal SNAPHAT	SH
M4T32-BR12SH	Lithium Battery (120mAh) and Crystal SNAPHAT	SH



**REVISION HISTORY****Table 21. Document Revision History**

<b>Date</b>	<b>Rev. #</b>	<b>Revision Details</b>
February 2002	1.0	First draft
27-Mar-02	1.1	Change $t_{REC}$ Definition (Table 8)
01-Apr-02	1.2	Addition of new package option and inherent features
12-Apr-02	2.0	Document promoted
21-Jan-03	2.1	Add marketing note; (Figure 1); modify logic, signals (Figure 3; Table 1); modify block diagram (Figure 6)
25-Feb-03	2.2	Update Definitions (Table 8); correct mechanical dimensions (Figure 25; Table 18)
20-Mar-03	3.0	Document promoted
27-Mar-03	3.1	Add marketing status (Table 19)
06-May-03	3.2	Update 32kHz information (Figure 3, 5, 6, 17; Table 1, 13, 14, 7)
15-Jun-04	4.0	Reformatted; update characteristics; added Lead-free information (Figure 5, 6, 18; Table 1, 4, 7, 8, 10, 13, 14, 19)
13-Sep-04	5.0	Update Maximum ratings (Table 10)

[www.BDTIC.com/ST](http://www.BDTIC.com/ST)

[www.BDTIC.com/ST](http://www.BDTIC.com/ST)

Information furnished is believed to be accurate and reliable. However, STMicroelectronics assumes no responsibility for the consequences of use of such information nor for any infringement of patents or other rights of third parties which may result from its use. No license is granted by implication or otherwise under any patent or patent rights of STMicroelectronics. Specifications mentioned in this publication are subject to change without notice. This publication supersedes and replaces all information previously supplied. STMicroelectronics products are not authorized for use as critical components in life support devices or systems without express written approval of STMicroelectronics.

The ST logo is a registered trademark of STMicroelectronics.

All other names are the property of their respective owners

© 2004 STMicroelectronics - All rights reserved

STMicroelectronics group of companies

Australia - Belgium - Brazil - Canada - China - Czech Republic - Finland - France - Germany - Hong Kong - India - Israel - Italy - Japan - Malaysia - Malta - Morocco - Singapore - Spain - Sweden - Switzerland - United Kingdom - United States of America

[www.st.com](http://www.st.com)

