



STA333W

2-channel high-efficiency digital audio system Sound Terminal™

Features

- Wide supply-voltage range (4.5 V - 20 V)
- 2 power output configurations
 - 2 channels of binary PWM (stereo mode)
 - 2 channels of ternary PWM (stereo mode)
- PowerSSO-36 with exposed pad down
- 2 channels of 24-bit DDX®
- 100-dB SNR and dynamic range
- Selectable 32- to 192-kHz input sample rates
- I²C control with selectable device address
- Digital gain -80 dB to +48 dB in 0.5-dB steps
- Software volume update
- Individual channel and master gain/attenuation
- Individual channel and master software and hardware mute
- Independent channel volume bypass
- Automatic zero-detect mute
- Automatic invalid input detect mute
- 2-channel I²S input data Interface
- Selectable clock input ratio
- Input channel mapping
- Automatic volume control for limiting maximum power
- 96-kHz internal processing sample rate, 24-bit precision
- Advanced AM interference frequency switching and noise suppression modes
- Thermal-overload and short-circuit protection embedded
- Video application: 576 * f_S input mode support

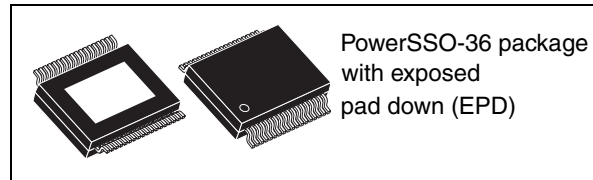

Applications

- LCD
- DVD
- Cradle
- Digital speaker
- Wireless-speaker cradle

Description

The STA333W is an integrated circuit comprising digital audio processing, digital amplifier control and DDX® power output stage to create a high-power, single-chip DDX® solution for all-digital amplification with high quality and high efficiency.

The STA333W power section consists of four independent half-bridges stages. These can be configured via digital control to operate in different modes. 2 channels can be provided by two full bridges, providing up to 20 W + 20 W of power.

Also provided in the STA333W are new advanced AM radio interference reduction modes. The serial audio data input interface accepts all possible formats, including the popular I²S format. Three channels of DDX® processing are provided.

The STA333W is part of the Sound Terminal™ family that provides full digital audio streaming to the speaker offering cost effectiveness, low power dissipation and sound enrichment.

Table 1. Device summary

Order code	Package	Packaging
STA333W	PowerSSO-36 EPD	Tube
STA333W13TR	PowerSSO-36 EPD	Tape and reel

Contents

- 1 Block diagram 7**

- 2 Pin description 8**
 - 2.1 Pin out 8
 - 2.2 Pin list 8
 - 2.3 Thermal data 10

- 3 Electrical specification 11**
 - 3.1 Absolute maximum ratings 11
 - 3.2 Recommended operating conditions 11
 - 3.3 Electrical specifications - digital section 12
 - 3.4 Electrical specifications - power section 12
 - 3.5 Power-on/off sequences 14
 - 3.6 Testing 15

- 4 Functional description 16**
 - 4.1 Functional pins 16
 - 4.1.1 Power-down function 16
 - 4.1.2 Reset function 16
 - 4.2 Serial audio interface description 17
 - 4.2.1 Serial audio interface protocols 17

- 5 I²C bus specification 18**
 - 5.1 Communication protocol 18
 - 5.1.1 Data transition or change 18
 - 5.1.2 Start condition 18
 - 5.1.3 Stop condition 18
 - 5.1.4 Data input 18
 - 5.2 Device addressing 18
 - 5.3 Write operation 19
 - 5.3.1 Byte write 19
 - 5.3.2 Multi-byte write 19
 - 5.4 Read operation 19

5.4.1	Current address byte read	19
5.4.2	Current address multi-byte read	19
5.4.3	Random address byte read	19
5.4.4	Random address multi-byte read	20
6	Register description	21
6.1	Configuration registers (addr 0x00 to 0x05)	22
6.1.1	Configuration register A (addr 0x00)	22
6.1.2	Configuration register B (addr 0x01)	24
6.1.3	Configuration register C (addr 0x02)	27
6.1.4	Configuration register D (addr 0x03)	28
6.1.5	Configuration register E (addr 0x04)	28
6.1.6	Configuration register F (addr 0x05)	30
6.2	Volume control registers (addr 0x06 to 0x09)	32
6.2.1	Mute/line output configuration register (addr 0x06)	32
6.2.2	Master volume register (addr 0x07)	33
6.2.3	Channel volume (addr 0x08, 0x09)	33
6.3	Automodes™ register (0x0C)	34
6.4	Channel configuration registers (addr 0x0E, 0x0F)	35
6.5	Variable max power correction registers (addr 0x27, 0x28)	35
6.6	Variable distortion compensation registers (addr 0x29, 0x2A)	36
6.7	Fault detect recovery constant registers (addr 0x2B, 0x2C)	36
6.8	Device status register (addr 0x2D)	36
6.9	Reserved registers (addr 0x2E, 0x2F, 0x30, 0x31)	37
6.10	Postscale registers (addr 0x32, 0x33)	37
6.11	Output limit register (addr 0x34)	38
6.11.1	Thermal and overcurrent warning output limit register	38
7	Applications information	39
7.1	Applications scheme for power supplies	39
7.2	PLL filter	39
7.3	Typical output configuration	40
8	Characterization data	41
9	Package thermal characteristics	44

10	Package mechanical data	45
11	Trademarks and other acknowledgements	47
12	Revision history	48

List of tables

Table 1.	Device summary	1
Table 2.	Pin description	8
Table 3.	Thermal data	10
Table 4.	Absolute maximum ratings	11
Table 5.	Recommended operating conditions	11
Table 6.	Electrical characteristics for digital section	12
Table 7.	Electrical specifications for power section	12
Table 8.	Register summary	21
Table 9.	Master clock select	22
Table 10.	MCS bits	22
Table 11.	Interpolation ratio select	23
Table 12.	IR bit settings as a function of input sample rate	23
Table 13.	Thermal warning recovery	23
Table 14.	Thermal warning adjustment	24
Table 15.	Fault detect recovery	24
Table 16.	Serial audio input interface format	25
Table 17.	Serial data first bit	25
Table 18.	Support serial audio input formats for MSB first (SAIFB = 0)	25
Table 19.	Supported serial audio input formats for LSB-First (SAIFB = 1)	26
Table 20.	Channel input mapping	27
Table 21.	DDX power output mode	27
Table 22.	DDX compensating pulse size	27
Table 23.	Overcurrent warning detect adjustment bypass	28
Table 24.	Zero detect mute enable	28
Table 25.	Max power correction variable	28
Table 26.	Max power correction	29
Table 27.	Noise-shaper bandwidth selection	29
Table 28.	AM mode enable	29
Table 29.	PWM speed mode	29
Table 30.	Distortion compensation variable enable	29
Table 31.	Zero-crossing volume enable	30
Table 32.	Zero-crossing volume enable	30
Table 33.	Invalid input detect mute enable	30
Table 34.	Binary output mode clock loss detection	30
Table 35.	LRCK double trigger protection	31
Table 36.	Auto EAPD on clock loss	31
Table 37.	Power down	31
Table 38.	External amplifier power down	31
Table 39.	Master mute	32
Table 40.	Channel mute	32
Table 41.	Master volume offset as a function of MV	33
Table 42.	Channel volume as a function of CxV	34
Table 43.	AM interference frequency switching	34
Table 44.	Automodes™ AM switching frequency selection	34
Table 45.	Status bits description	36
Table 46.	Output limit values for thermal and overcurrent warnings	38
Table 47.	PowerSSO-36 EPD dimensions	46
Table 48.	Document revision history	48

List of figures

Figure 1.	Block diagram	7
Figure 2.	Pin connection (package top view)	8
Figure 3.	Power-on sequence	14
Figure 4.	Power-off sequence	14
Figure 5.	Test circuit	15
Figure 6.	Current dead-time test circuit	15
Figure 7.	I ² S	17
Figure 8.	Left justified	17
Figure 9.	Write-mode sequence	19
Figure 10.	Read-mode sequence	20
Figure 11.	Applications diagram	39
Figure 12.	PLL filter circuit	40
Figure 13.	Output configuration for stereo BTL mode	40
Figure 14.	Output power vs. supply voltage (THD = 1%)	41
Figure 15.	FFT 0 dBfs (V _{CC} = 12 V)	41
Figure 16.	FFT -60 dBfs (V _{CC} = 12 V)	42
Figure 17.	THD vs. frequency (V _{CC} = 12 V, P _o = 1 W)	42
Figure 18.	FFT 0 dBfs (V _{CC} = 18 V)	43
Figure 19.	FFT -60 dBfs (V _{CC} = 18 V)	43
Figure 20.	THD vs. frequency (V _{CC} = 18 V, P _o = 1 W)	43
Figure 21.	Double-layer PCB with two copper ground areas and 16 vias	44
Figure 22.	Power derating curve for PCB used as heatsink	44
Figure 23.	PowerSSO-36 EPD outline drawing	45

1 Block diagram

Figure 1. Block diagram

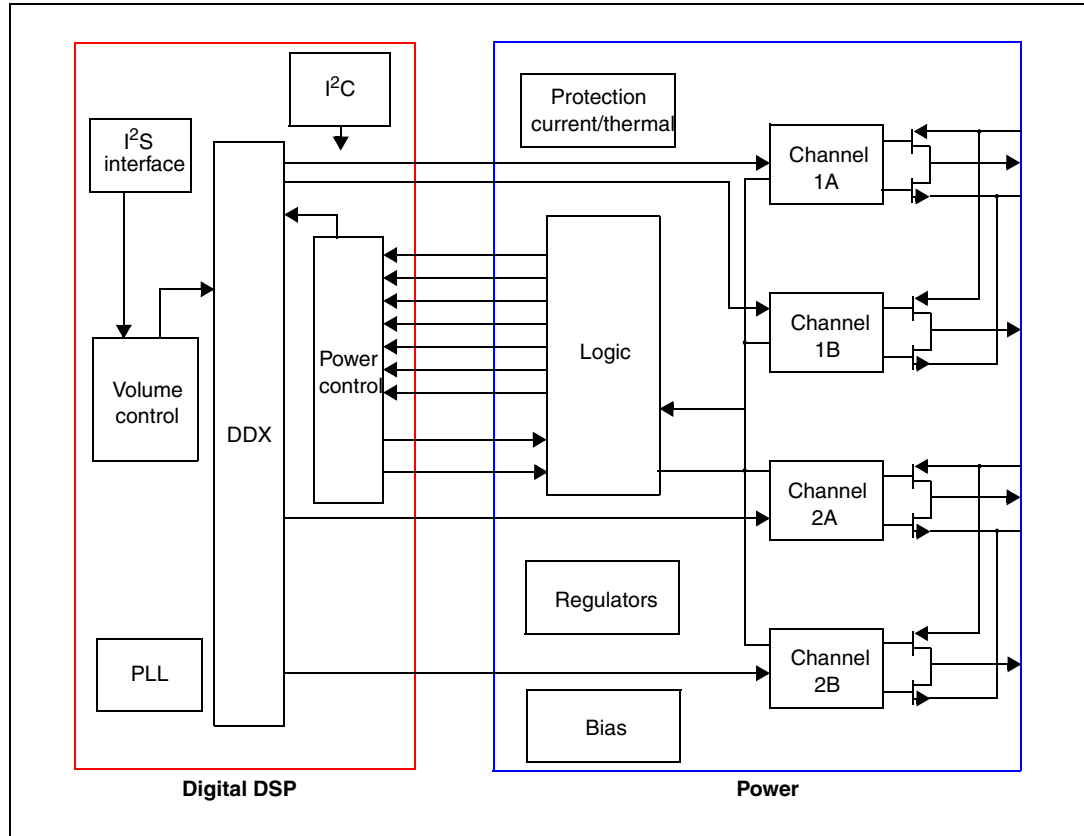

2 Pin description

2.1 Pin out

Figure 2. Pin connection (package top view)

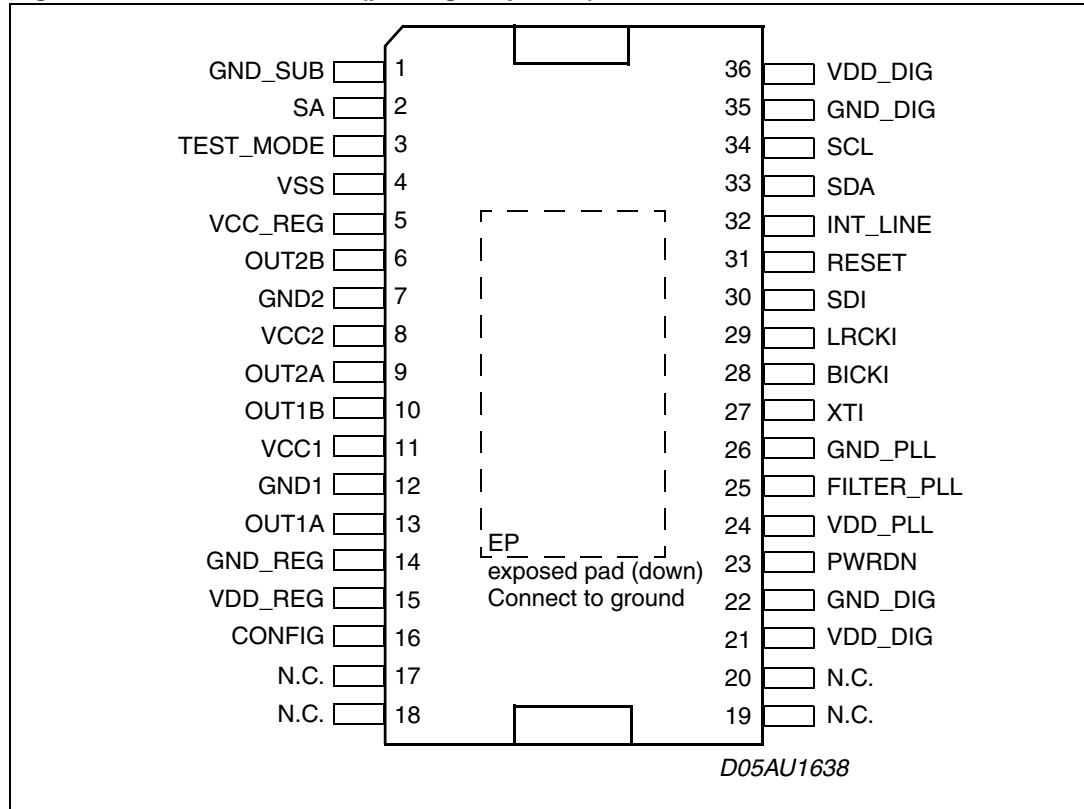

2.2 Pin list

Table 2. Pin description

Number	Type	Name	Description
1	PWR	GND_SUB	Substrate ground
2	I	SA	I ² C select address
3	I	TEST_MODE	This pin must be connected to ground
4	I/O	VSS	Internal reference at V _{CC} - 3.3 V
5	I/O	VCC_REG	Internal V _{CC} reference
6	O	OUT2B	Output half bridge 2B
7	PWR	GND2	Power negative supply
8	PWR	VCC2	Power positive supply
9	O	OUT2A	Output half bridge 2A

Table 2. Pin description (continued)

Number	Type	Name	Description
10	O	OUT1B	Output half bridge 1B
11	PWR	VCC1	Power positive supply
12	PWR	GND1	Power negative supply
13	O	OUT1A	Output half bridge 1A
14	PWR	GND_REG	Internal ground reference
15	PWR	VDD_REG	Internal 3.3-V reference voltage
16	I	CONFIG	Paralleled mode command
17	-	N.C.	No internal connection
18	-	N.C.	No internal connection
19	-	N.C.	No internal connection
20	-	N.C.	No internal connection
21	PWR	VDD_DIG	Positive supply digital
22	PWR	GND_DIG	Digital ground
23	I	PWRDN	Power down: 0: power stage is switched off then the PLL is also switched off (this operation take 13 million clock cycles) 1: normal operation
24	PWR	VDD_PLL	Positive supply for PLL
25	I	FILTER_PLL	Connection to PLL filter
26	PWR	GND_PLL	Negative supply for PLL
27	I	XTI	PLL input clock, $256 * f_S$, or $384 * f_S$
28	I	BICKI	I ² S serial clock
29	I	LRCKI	I ² S left/right clock
30	I	SDI	I ² S serial data channel
31	I	RESET	Reset: 0: reset state, power stage is switched off, all registers are set to default value 1: normal operation
32	O	INT_LINE	Fault interrupt
33	I/O	SDA	I ² C serial data, used as SDA_OUT
34	I	SCL	I ² C serial clock
35	PWR	GND_DIG	Digital ground
36	PWR	VDD_DIG	Digital supply
-	-	EP	Exposed pad for ground-plane heatsink, to be connected to GND

2.3 Thermal data

Table 3. Thermal data

Symbol	Parameter	Min	Typ	Max	Unit
$R_{Th(j-case)}$	Thermal resistance junction to case (thermal pad)	-	1.5	2.0	°C/W
T_{sd}	Thermal-shutdown junction temperature	140	150	160	°C
T_w	Thermal-warning temperature	-	130	-	°C
T_{hsd}	Thermal-shutdown hysteresis	18	20	22	°C

3 Electrical specification

3.1 Absolute maximum ratings

Table 4. Absolute maximum ratings

Symbol	Parameter	Min	Typ	Max	Unit
V _{CC}	Analog supply voltage (pins VCCx)	-	-	23	V
V _{DD}	Digital supply voltage (pins VDD_DIG)	-	-	4.0	V
I _L	Logic input interface	-0.3	-	4.0	V
T _{op}	Operating junction temperature	0	-	150	°C
T _{stg}	Storage temperature	-40	-	150	°C

Warning: Stresses beyond those listed in [Table 4: Absolute maximum ratings](#) may cause permanent damage to the device. These are stress ratings only, and functional operation of the device at these or any other conditions beyond those indicated in [Table 5: Recommended operating conditions](#) are not implied. Exposure to absolute-maximum-rated conditions for extended periods may affect device reliability. In the real application, a power supply with nominal value rated within the limits of the recommended operating conditions, may experience some rising beyond the maximum operating conditions for a short time when no or very low current is being sunk (amplifier in mute state). In this case the reliability of the device is guaranteed, provided that the absolute maximum ratings are not exceeded.

3.2 Recommended operating conditions

Table 5. Recommended operating conditions

Symbol	Parameter	Min	Typ	Max	Unit
V _{CC}	Analog supply voltage (VCCx)	4.5	-	20.0	V
V _{DD}	Digital supply voltage (VDD_DIG)	2.7	3.3	3.6	V
I _L	Logic input interface	2.7	3.3	3.6	V
T _{amb}	Ambient temperature	0	-	70	°C

3.3 Electrical specifications - digital section

Table 6. Electrical characteristics for digital section

Symbol	Parameter	Conditions	Min	Typ	Max	Unit
I_{il}	Input current, no pull-up or pull-down resistor	$V_i = 0\text{ V}$	-	-	± 10	μA
I_{ih}		$V_i = V_{DD} = 3.6\text{ V}$	-	-	± 10	μA
V_{il}	Low-level input voltage	-	-	-	$0.2 * V_{DD}$	V
V_{ih}	High-level input voltage	-	$0.8 * V_{DD}$	-	-	V
V_{ol}	Low-level output voltage	$I_{ol} = 2\text{ mA}$	-	-	$0.4 * V_{DD}$	V
V_{oh}	High-level output voltage	$I_{oh} = 2\text{ mA}$	$0.8 * V_{DD}$	-	-	V
I_{pu}	Pull-up current	-	25	66	125	μA
R_{pu}	Equivalent pull-up resistance	-	-	50	-	$\text{k}\Omega$

3.4 Electrical specifications - power section

The specifications in [Table 7](#) below are given for the conditions $V_{CC} = 18\text{ V}$, $V_{DD} = 3.3\text{ V}$, $f_{SW} = 384\text{ kHz}$, $T_{amb} = 25\text{ }^\circ\text{C}$ and $R_L = 8\text{ }\Omega$, unless otherwise specified.

Table 7. Electrical specifications for power section

Symbol	Parameter	Conditions	Min	Typ	Max	Unit
P_o	Output power BTL	THD = 1%	-	16	-	W
		THD = 10%	-	20	-	
R_{dsON}	Power P-channel/N-channel MOSFET (total bridge)	$I_d = 1\text{ A}$	-	180	250	$\text{m}\Omega$
I_{dss}	Power P-channel/N-channel leakage	$V_{CC} = 18\text{ V}$	-	-	10	μA
g_P	Power P-channel R_{dsON} matching	$I_d = 1\text{ A}$	95	-	-	%
g_N	Power N-channel R_{dsON} matching	$I_d = 1\text{ A}$	95	-	-	%
I_{LDT}	Low-current dead time (static)	Resistive load, refer to Figure 5	-	5	10	ns
I_{HDT}	High-current dead time (dynamic)	Refer to Figure 6	-	10	20	ns
t_r	Rise time	Resistive load, refer to Figure 5	-	8	10	ns
t_f	Fall time	Resistive load, refer to Figure 5	-	8	10	ns

Table 7. Electrical specifications for power section (continued)

Symbol	Parameter	Conditions	Min	Typ	Max	Unit
V_{CC}	Supply voltage	-	4.5	-	20	V
I_{VCC}	Supply current from V_{CC} in power down	PWRDN = 0	30	60	200	μ A
	Supply current from V_{CC} in operation	PCM input signal = -60 dBfs Switching frequency = 384 kHz No LC filters	-	30	50	mA
I_{VDD_DIG}	Supply current for DDX processing (reference only)	Internal clock = 49.152 MHz	10	30	50	mA
	Supply current in standby	-	8	11	25	mA
I_{LIM}	Overcurrent limit	Non-linear output ⁽¹⁾	2.2	3.5	4.3	A
I_{SCP}	Short-circuit protection	High-impedance output ⁽²⁾	2.7	3.8	5.0	A
V_{UVP}	Undervoltage protection threshold	-	-	3.5	4.3	V
t_{min}	Output minimum pulse width	No load	20	30	60	ns
THD+N	Total harmonic distortion and noise	DXX stereo mode, $P_o = 1$ W, $f = 1$ kHz	-	0.05	0.2	%
DR	Dynamic range	-	-	100	-	dB
SNR	Signal to noise ratio in ternary mode	A-weighted	-	100	-	dB
	Signal to noise ratio in binary mode	A-weighted	-	90	-	
PSRR	Power supply rejection ratio	DXX stereo mode, < 5 kHz, $V_{RIPPLE} = 1$ V RMS audio input = dither only	-	80	-	dB
X_{TALK}	Crosstalk	DXX stereo mode, < 5 kHz, One channel driven at 1 W the other channel measured	-	80	-	dB
η	Peak efficiency in DXX mode	$P_o = 2 \times 20$ W into 8Ω	-	90	-	%

1. The I_{LIM} data is for 1 channel of BTL configuration, thus, $2 * I_{LIM}$ drives the 2-channel BTL configuration. The current limit is active when $OCRB = 0$ (see [Table 23: Overcurrent warning detect adjustment bypass on page 28](#)). When $OCRB = 1$ then I_{SC} applies.
2. The I_{SCP} current limit data is for 1 channel of BTL configuration, thus, $2 * I_{SCP}$ drives the 2-channel BTL configuration. The short-circuit current is applicable when $OCRB = 1$ (see [Table 23: Overcurrent warning detect adjustment bypass on page 28](#)).

3.5 Power-on/off sequences

The power-on/off sequences shown in *Figure 3* and *Figure 4* below ensure a pop-free turn on and turn off.

Figure 3. Power-on sequence

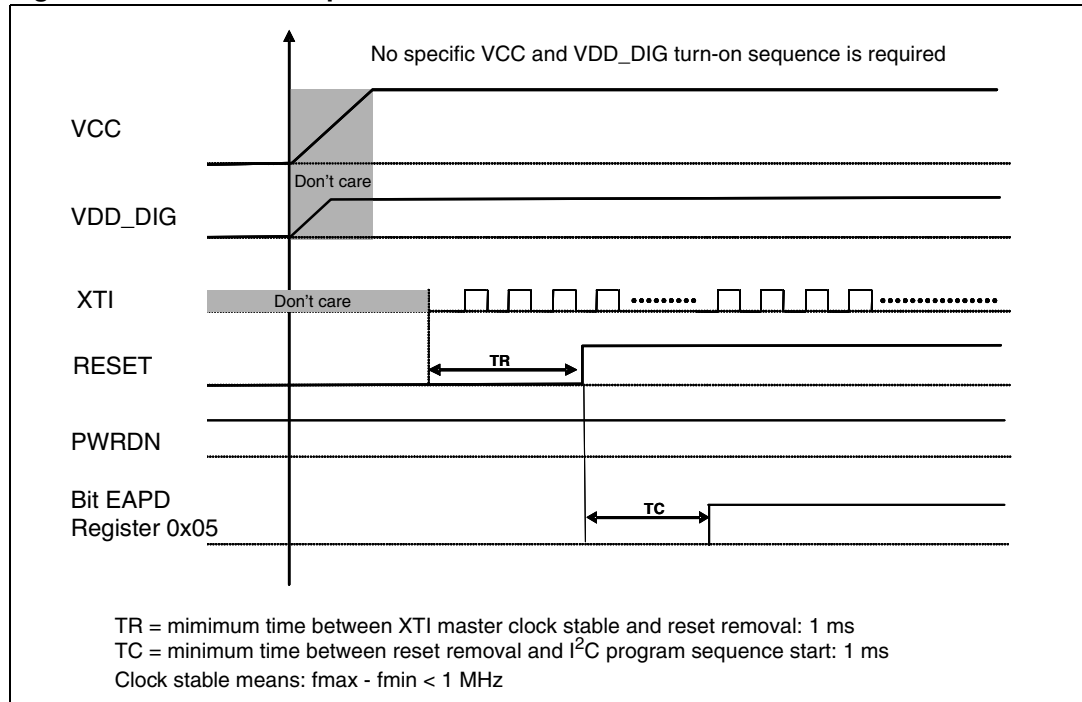
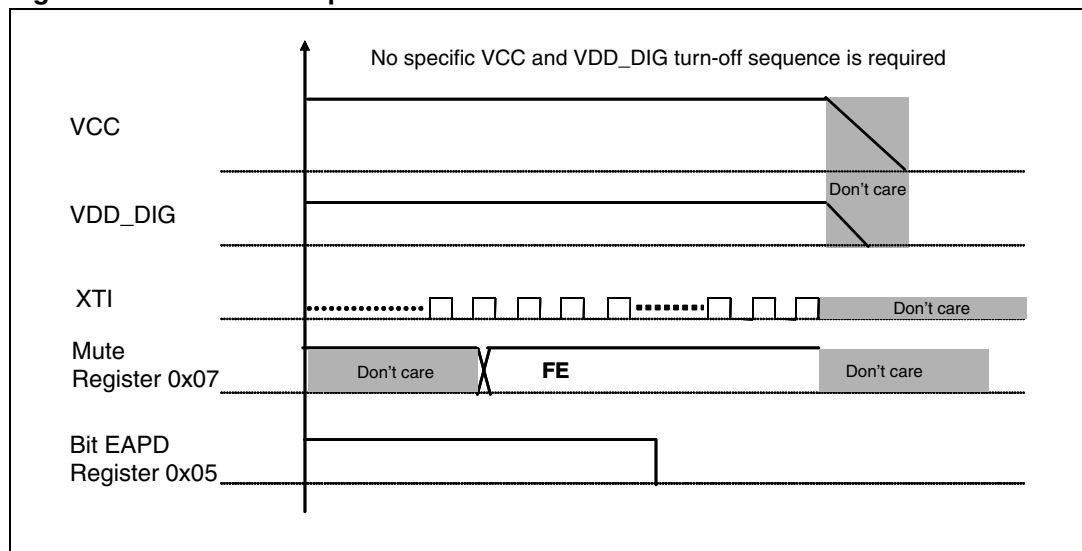

Figure 4. Power-off sequence



3.6 Testing

Figure 5. Test circuit

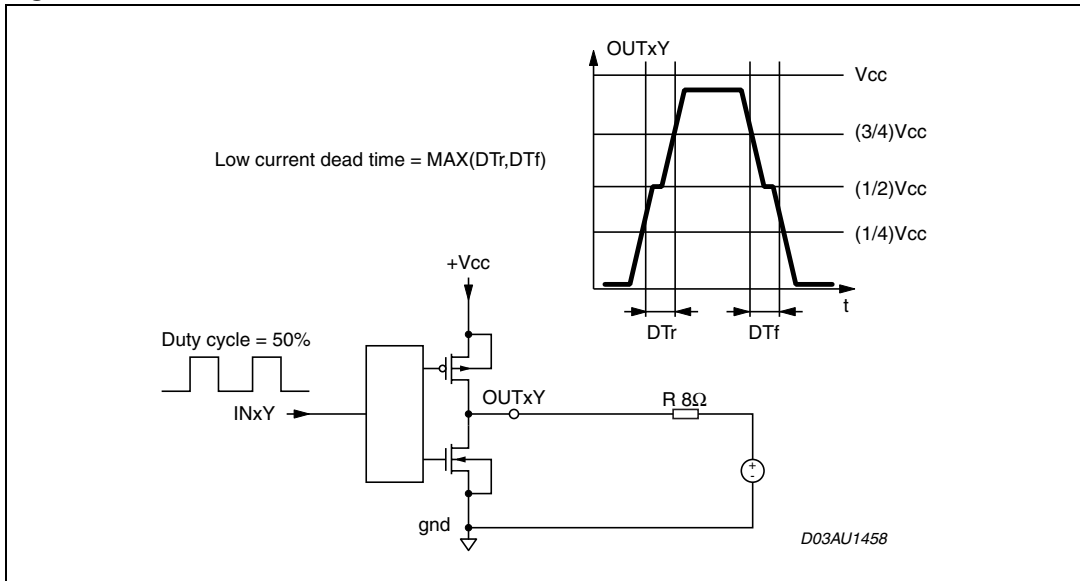
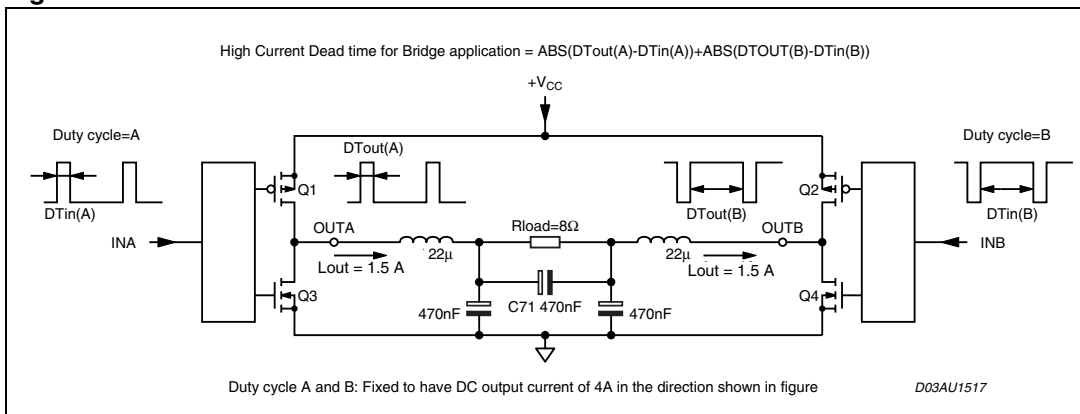

Figure 6. Current dead-time test circuit



4 Functional description

4.1 Functional pins

4.1.1 Power-down function

Pin PWRDN (23) is used to power down the STA333W.

PWRDN = 0 (0 V): power-down state.

PWRDN = 1 (V_{DD}): normal operation.

During the power-down sequence the output begins to mute. After the mute condition is reached the power stage is switched off and the output becomes high impedance. Then the master clock to all internal hardware blocks is gated off. The PLL is also switched off. The complete power-down sequence takes 13 million cycles.

4.1.2 Reset function

Pin RESET (31) is used to reset the STA333W.

RESET = 0 (0 V): reset state.

RESET = 1 (V_{DD}): normal operation.

When pin RESET is forced to 0 the power stage is switched off (with high-impedance output) and the master clock to all internal hardware blocks is gated off.

Note: Reset has a higher priority than power down.

4.2 Serial audio interface description

4.2.1 Serial audio interface protocols

The STA333W serial audio input was designed to interface with standard digital audio components and to accept serial data formats. The STA333W always acts as a slave when receiving audio input from standard digital audio components. Serial data for two channels is provided using 3 input pins: left/right clock LRCLKI (pin 29), serial clock BICKI (pin 28), and serial data SDI (pin 30).

The available formats are showed in [Table 7](#) and [Table 8](#), and set through register CONFB [on page 24](#).

Figure 7. I²S

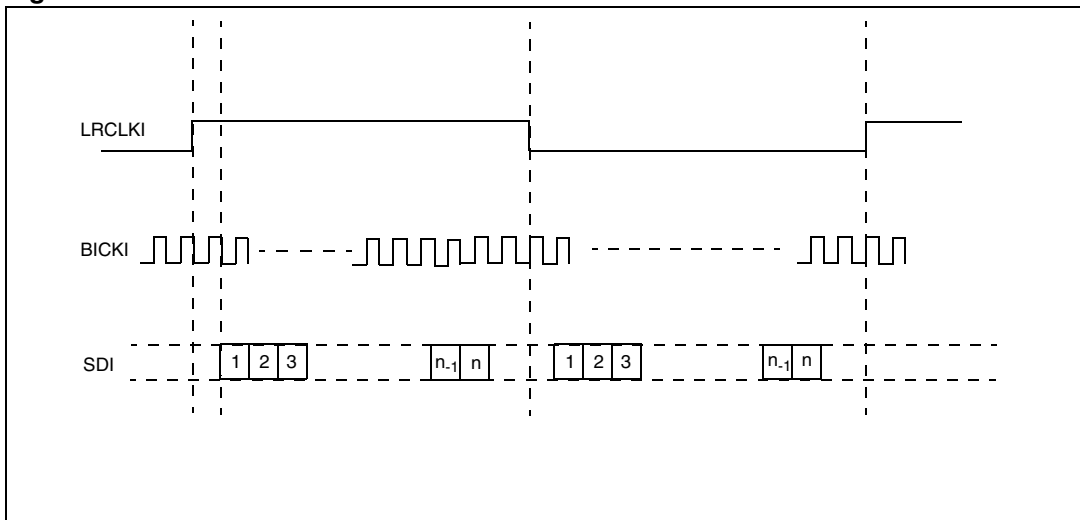
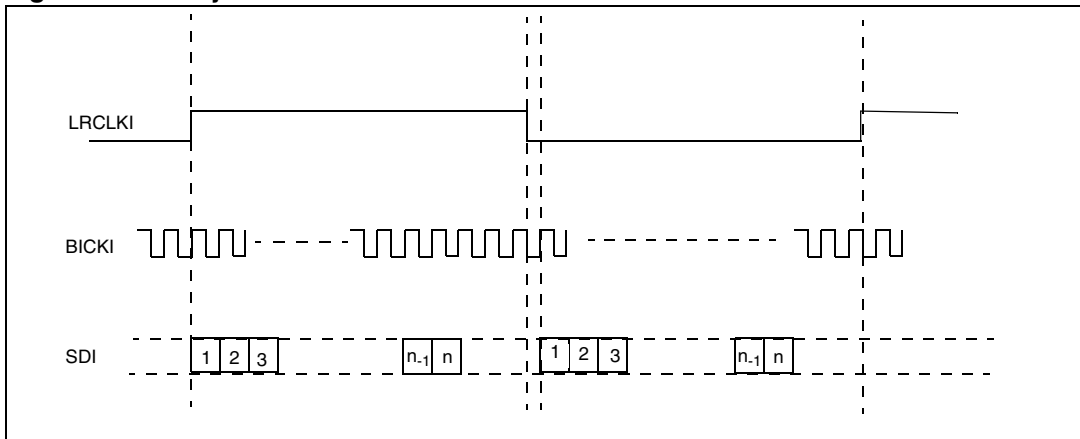

Figure 8. Left justified



5 I²C bus specification

The STA333W supports the I²C protocol via the input ports SCL and SDA. This protocol defines any device that sends data on to the bus as a transmitter and any device that reads the data as a receiver. The device that controls the data transfer is known as the master and the other as the slave. The master always starts the transfer and provides the serial clock for synchronization. The STA333W is always a slave device in all of its communications. It supports up to 400 kb/s (fast-mode bit rate).

5.1 Communication protocol

5.1.1 Data transition or change

Data changes on the SDA line must only occur when the SCL clock is low. SDA transition while the clock is high is used to identify a START or STOP condition.

5.1.2 Start condition

START is identified by a high to low transition of the data bus SDA signal while the clock signal SCL is stable in the high state. A START condition must precede any command for data transfer.

5.1.3 Stop condition

STOP is identified by low to high transition of the data bus SDA signal while the clock signal SCL is stable in the high state. A STOP condition terminates communication between STA333W and the bus master.

5.1.4 Data input

During the data input the STA333W samples the SDA signal on the rising edge of clock SCL. For correct device operation the SDA signal must be stable during the rising edge of the clock and the data can change only when the SCL line is low.

5.2 Device addressing

To start communication between the master and the STA333W, the master must initiate a start condition. Following this, the master sends onto the SDA line 8 bits (MSB first) corresponding to the device-select address and read or write mode.

The 7 most significant bits are the device address identifiers, corresponding to the I²C bus definition. In the STA333W the I²C interface has two device addresses depending on the SA port configuration, 0x38 when SA = 0, and 0x3A when SA = 1.

The 8th bit (LSB) identifies read or write operation RW, this bit is set to 1 for read mode and 0 for write mode. After a START condition the STA333W identifies the device address on the SDA bus and if a match is found, acknowledges the identification during the 9th bit time. The byte following the device identification byte is the internal space address.

5.3 Write operation

Following the START condition the master sends a device select code with the RW bit set to 0. The STA333W acknowledges this and then waits for the byte of internal address. After receiving the internal byte address the STA333W again responds with an acknowledgement.

5.3.1 Byte write

In the byte write mode the master sends one data byte, this is acknowledged by the STA333W. The master then terminates the transfer by generating a STOP condition.

5.3.2 Multi-byte write

The multi-byte write modes can start from any internal address. The master generating a STOP condition terminates the transfer.

Figure 9. Write-mode sequence

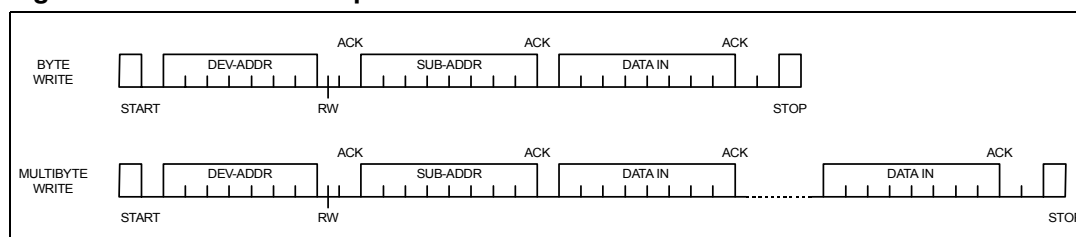

5.4 Read operation

5.4.1 Current address byte read

Following the START condition the master sends a device select code with the RW bit set to 1. The STA333W acknowledges this and then responds by sending one byte of data. The master then terminates the transfer by generating a STOP condition.

5.4.2 Current address multi-byte read

The multi-byte read modes can start from any internal address. Sequential data bytes are read from sequential addresses within the STA333W. The master acknowledges each data byte read and then generates a STOP condition terminating the transfer.

5.4.3 Random address byte read

Following the START condition the master sends a device select code with the RW bit set to 0. The STA333W acknowledges this and then the master writes the internal address byte. After receiving, the internal byte address the STA333W again responds with an acknowledgement. The master then initiates another START condition and sends the device select code with the RW bit set to 1. The STA333W acknowledges this and then responds by sending one byte of data. The master then terminates the transfer by generating a STOP condition.

5.4.4 Random address multi-byte read

The multi-byte read modes could start from any internal address. Sequential data bytes are read from sequential addresses within the STA333W. The master acknowledges each data byte read and then generates a STOP condition to terminate the transfer.

Figure 10. Read-mode sequence

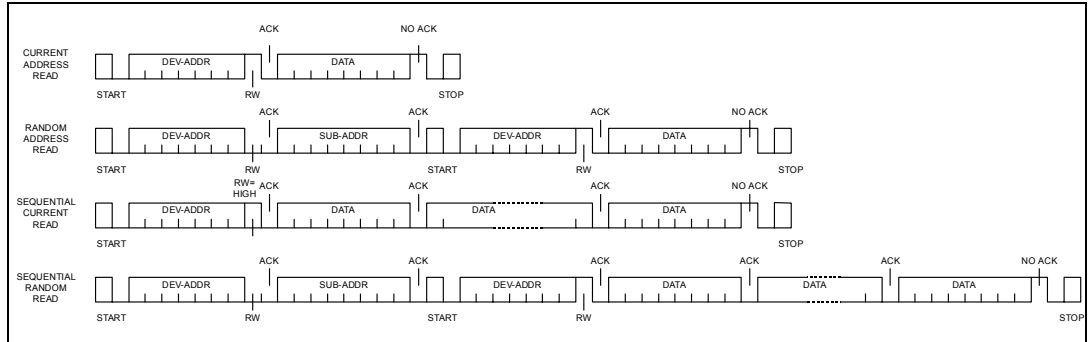

6 Register description

Table 8. Register summary

Addr	Name	D7	D6	D5	D4	D3	D2	D1	D0
0x00	CONFA	FDRB	TWAB	TWRB	IR1	IR0	MCS2	MCS1	MCS0
0x01	CONFB	C2IM	C1IM	Reserved	SAIFB	SAI3	SAI2	SAI1	SAI0
0x02	CONFC	OCRB	Reserved	CSZ3	CSZ2	CSZ1	CSZ0	OM1	OM0
0x03	CONFD	Reserved	ZDE	Reserved					
0x04	CONFE	SVE	ZCE	DCCV	PWMS	AME	NSBW	MPC	MPCV
0x05	CONFF	EAPD	PWDN	ECLE	LDTE	BCLE	IDE	Reserved	
0x06	MUTE	Reserved					C2M	C1M	MMUTE
0x07	MVOL	MV7	MV6	MV5	MV4	MV3	MV2	MV1	MV0
0x08	C1VOL	C1V7	C1V6	C1V5	C1V4	C1V3	C1V2	C1V1	C1V0
0x09	C2VOL	C2V7	C2V6	C2V5	C2V4	C2V3	C2V2	C2V1	C2V0
0x0C	AUTO	Reserved				AMAM2	AMAM1	AMAM0	AMAME
0x0E	C1CFG	Reserved					C1VBP	Reserved	
0x0F	C2CFG	Reserved					C2VBP	Reserved	
0x27	MPCC1	MPCC15	MPCC14	MPCC13	MPCC12	MPCC11	MPCC10	MPCC9	MPCC8
0x28	MPCC2	MPCC7	MPCC6	MPCC5	MPCC4	MPCC3	MPCC2	MPCC1	MPCC0
0x29	DCC1	DCC15	DCC14	DCC13	DCC12	DCC11	DCC10	DCC9	DCC8
0x2A	DCC2	DCC7	DCC6	DCC5	DCC4	DCC3	DCC2	DCC1	DCC0
0x2B	FDRC1	FDRC15	FDRC14	FDRC13	FDRC12	FDRC11	FDRC10	FDRC9	FDRC8
0x2C	FDRC2	FDRC7	FDRC6	FDRC5	FDRC4	FDRC3	FDRC2	FDRC1	FDRC0
0x2D	STATUS	PLLUL	FAULT	UVFAULT	Reserved	OCFAULT	OCWARN	TFAULT	TWARN
0x2E	BIST1	Reserved		RO1BACT	R5BACT	R4BACT	R3BACT	R2BACT	R1BACT
0x2F	BIST2	Reserved		RO1BEND	R5BEND	R4BEND	R3BEND	R2BEND	R1BEND
0x30	BIST3	Reserved			R5BBAD	R4BBAD	R3BBAD	R1BBAD	R1BBAD
0x31	TSTCTL	Reserved							
0x32	C1PS	C1PS7	C1PS6	C1PS5	C1PS4	C1PS3	C1PS2	C1PS1	C1PS0
0x33	C2PS	C2PS7	C2PS6	C2PS5	C2PS4	C2PS3	C2PS2	C2PS1	C2PS0
0x34	OLIM	OLIM7	OLIM6	OLIM5	OLIM4	OLIM3	OLIM2	OLIM1	OLIM0

6.1 Configuration registers (addr 0x00 to 0x05)

6.1.1 Configuration register A (addr 0x00)

D7	D6	D5	D4	D3	D2	D1	D0
FDRB	TWAB	TWRB	IR1	IR0	MCS2	MCS1	MCS0
0	1	1	0	0	0	1	1

Master clock select

Table 9. Master clock select

Bit	R/W	RST	Name	Description
0	R/W	1	MCS0	Master clock select: Selects the ratio between the input I ² S sample frequency and the input clock.
1	R/W	1	MCS1	
2	R/W	0	MCS2	

The STA333W supports sample rates of 32 kHz, 44.1 kHz, 48 kHz, 88.2 kHz, 96 kHz, 176.4 kHz, and 192 kHz. Therefore the internal clock is:

- 32.768 MHz for 32 kHz
- 45.1584 MHz for 44.1 kHz, 88.2 kHz, and 176.4 kHz
- 49.152 MHz for 48 kHz, 96 kHz, and 192 kHz

The external clock frequency provided to the XTI pin must be a multiple of the input sample frequency (f_S).

The relationship between the input clock and the input sample rate is determined by both the MCSx and the IR (input rate) register bits. The MCSx bits determine the PLL factor generating the internal clock and the IR bit determines the oversampling ratio used internally.

Table 10. MCS bits

Input sample rate f_S (kHz)	IR	MCS[2:0]					
		101	100	011	010	001	000
32, 44.1, 48	00	$576 * f_S$	$128 * f_S$	$256 * f_S$	$384 * f_S$	$512 * f_S$	$768 * f_S$
88.2, 96	01	NA	$64 * f_S$	$128 * f_S$	$192 * f_S$	$256 * f_S$	$384 * f_S$
176.4, 192	1X	NA	$32 * f_S$	$64 * f_S$	$96 * f_S$	$128 * f_S$	$192 * f_S$

Interpolation ratio select

Table 11. Interpolation ratio select

Bit	R/W	RST	Name	Description
4:3	R/W	00	IR [1:0]	Interpolation ratio select: Selects internal interpolation ratio based on input I ² S sample frequency.

The STA333W has variable interpolation (oversampling) settings such that internal processing and DDX output rates remain consistent. The first processing block interpolates by either 2 times or 1 time (pass-through) or provides a 2-times downsample. The oversampling ratio of this interpolation is determined by the IR bits.

Table 12. IR bit settings as a function of input sample rate

Input sample rate f_s (kHz)	IR	1 st stage interpolation ratio
32	00	2-times oversampling
44.1	00	2-times oversampling
48	00	2-times oversampling
88.2	01	Pass-through
96	01	Pass-through
176.2	10	2-times downsampling
192	10	2-times downsampling

Thermal warning recovery bypass

Table 13. Thermal warning recovery

Bit	R/W	RST	Name	Description
5	R/W	1	TWRB	Thermal warning recovery bypass: 0: thermal warning recovery enabled 1: thermal warning recovery disabled

If the thermal warning adjustment is enabled (TWAB = 0), then the thermal warning recovery determines if the -3 dB output limit is removed when thermal warning is negative.

If TWRB = 0 and TWAB = 0, then when a thermal warning disappears the -3 dB output limit is removed and the gain is added back to the system. If TWRB = 1 and TWAB = 0, then when a thermal warning disappears the -3 dB output limit remains until TWRB is changed to zero or the device is reset.

Thermal warning adjustment bypass

Table 14. Thermal warning adjustment

Bit	R/W	RST	Name	Description
6	R/W	1	TWAB	Thermal warning adjustment bypass: 0: thermal warning adjustment enabled 1: thermal warning adjustment disabled

The on-chip STA333W power output block provides feedback to the digital controller using inputs to the power control block. The TWARN input is used to indicate a thermal warning condition. When TWARN is asserted (set to 0) for a period of time greater than 400 ms, the power control block will force a -3dB output limit (determined by TWOCL in coefficient RAM) to the modulation limit in an attempt to eliminate the thermal warning condition. Once the thermal warning output limit adjustment is applied, it remains in this state until reset, unless FDRB = 0.

Fault detect recovery bypass

Table 15. Fault detect recovery

Bit	R/W	RST	Name	Description
7	R/W	0	FDRB	Fault detect recovery bypass: 0: fault detect recovery enabled 1: fault detect recovery disabled

The on-chip STA333W power output block provides feedback to the digital controller using inputs to the power control block. The FAULT input is used to indicate a fault condition (either overcurrent or thermal). When FAULT is asserted (set to 0), the power control block attempts a recovery from the fault by asserting the 3-state output (setting it to 0 which directs the power output block to begin recovery), holding it at 0 for period of time in the range of 0.1 ms to 1 second as defined by the fault detect recovery constant register (FDRC registers 0x2B, 0x2C), then toggling it back to 1. This sequence is repeated as long as the fault indication exists. This feature is enabled by default but can be bypassed by setting the FDRB control bit to 1.

6.1.2 Configuration register B (addr 0x01)

D7	D6	D5	D4	D3	D2	D1	D0
C2IM	C1IM	Reserved	SAIFB	SAI3	SAI2	SAI1	SAI0
1	0	0	0	0	0	0	0

Serial audio input interface format

Table 16. Serial audio input interface format

Bit	R/W	RST	Name	Description
0	R/W	0	SAI0	Determines the interface format of the input serial digital audio interface.
1	R/W	0	SAI1	
2	R/W	0	SAI2	
3	R/W	0	SAI3	

Serial data interface

The STA333W audio serial input interfaces with standard digital audio components and accepts a number of serial data formats. STA333W always acts a slave when receiving audio input from standard digital audio components. Serial data for two channels is provided using three inputs: left/right clock LRCKI, serial clock BICKI, and serial data SDI.

Bits SAI and bit SAIFB are used to specify the serial data format. The default serial data format is I²S, MSB first. Available formats are shown in the tables and figure that follow.

Serial data first bit

Table 17. Serial data first bit

SAIFB	Format
0	MSB-first
1	LSB-first

Table 18. Support serial audio input formats for MSB first (SAIFB = 0)

BICKI	SAI [3:0]	SAIFB	Interface format
32 * f _S	0000	0	I ² S 15-bit data
	0001	0	Left/right justified 16-bit data
48* f _S	0000	0	I ² S 16- to 23-bit data
	0001	0	Left justified 16- to 24-bit data
	0010	0	Right justified 24-bit data
	0110	0	Right justified 20-bit data
	1010	0	Right justified 18-bit data
	1110	0	Right justified 16-bit data

Table 18. Support serial audio input formats for MSB first (SAIFB = 0) (continued)

64* f _S	0000	0	I ² S 16- to 24-bit data
	0001	0	Left justified 16- to 24-bit data
	0010	0	Right justified 24-bit data
	0110	0	Right justified 20-bit data
	1010	0	Right justified 18-bit data
	1110	0	Right justified 16-bit data

Table 19. Supported serial audio input formats for LSB-First (SAIFB = 1)

BICKI	SAI[3:0]	SAIFB	Interface format
32* f _S	1100	1	I ² S 15-bit data
	1110	1	Left/right justified 16-bit data
48* f _S	0100	1	I ² S 23-bit data
	0100	1	I ² S 20-bit data
	1000	1	I ² S 18-bit data
	1100	1	LSB first I ² S 16-bit data
	0001	1	Left justified 24-bit data
	0101	1	Left justified 20-bit data
	1001	1	Left justified 18-bit data
	1101	1	Left justified 16-bit data
48* f _S	0010	1	Right justified 24-bit data
	0110	1	Right justified 20-bit data
	1010	1	Right justified 18-bit data
64* f _S	1110	1	Right justified 16-bit data
	0000	1	I ² S 24-bit data
	0100	1	I ² S 20-bit data
	1000	1	I ² S 18-bit data
	1100	1	LSB First I ² S 16-bit data
	0001	1	Left justified 24-bit data
	0101	1	Left justified 20-bit data
	1001	1	Left justified 18-bit data
	1101	1	Left justified 16-bit data
	0010	1	Right justified 24-bit data
	0110	1	Right justified 20-bit data
	1010	1	Right justified 18-bit data
1110	1	Right justified 16-bit data	

Channel input mapping

Table 20. Channel input mapping

Bit	R/W	RST	Name	Description
6	R/W	0	C1IM	0: processing channel 1 receives left I ² S input 1: processing channel 1 receives right I ² S input
7	R/W	0	C2IM	0: processing channel 2 receives left I ² S input 1: processing channel 2 receives right I ² S input

Each channel received via I²S can be mapped to any internal processing channel via the channel input mapping registers. This allows for flexibility in processing. The default settings of these registers map each I²S input channel to its corresponding processing channel.

6.1.3 Configuration register C (addr 0x02)

D7	D6	D5	D4	D3	D2	D1	D0
OCRB	Reserved	CSZ3	CSZ2	CSZ1	CSZ0	OM1	OM0
1	0	0	1	0	1	1	1

DDX power output mode

Table 21. DDX power output mode

Bit	R/W	RST	Name	Description
0	R/W	1	OM0	The DDX power output mode selects the configuration of the DDX output: 00: drop compensation 01: discrete output stage: tapered compensation 10: full-power mode 11: variable drop compensation (CSZx bits)
1	R/W	1	OM1	

DDX compensation pulse size register

Table 22. DDX compensating pulse size

Bit	R/W	RST	Name	Description
2	R/W	1	CSZ0	When OM[1:0] = 11, this register determines the size of the DDX compensating pulse from 0 to 15 clock periods: 0000: 0 ns (0 ticks) compensating pulse size 0001: 20 ns (1 tick) clock period compensating pulse size 1111: 300 ns (15 ticks) clock period compensating pulse size
3	R/W	0	CSZ1	
4	R/W	1	CSZ2	
5	R/W	0	CSZ3	

Overcurrent warning detect adjustment bypass

Table 23. Overcurrent warning detect adjustment bypass

Bit	R/W	RST	Name	Description
7	R/W	1	OCRB	0: overcurrent warning adjustment enabled 1: overcurrent warning adjustment disabled

The status bit OCWARN is used to warn of an overcurrent condition. When OCWARN is asserted (set to 0), the power control block forces an adjustment to the modulation limit (default -3dB) in an attempt to eliminate the overcurrent warning condition. Once the overcurrent warning volume adjustment is applied, it remains applied until the device is reset. The overcurrent limit can be changed via register OLIM (*Output limit register (addr 0x34) on page 38*).

6.1.4 Configuration register D (addr 0x03)

D7	D6	D5	D4	D3	D2	D1	D0
Reserved	ZDE	Reserved					
0	1	0	0	0	0	0	0

Zero-detect mute enable

Table 24. Zero detect mute enable

Bit	R/W	RST	Name	Description
6	R/W	1	ZDE	1: enable the automatic zero-detect mute

Setting the ZDE bit enables the zero-detect automatic mute. The zero-detect circuit looks at the data for each processing channel at the output of the crossover (bass management) filter. If any channel receives 2048 consecutive zero value samples (regardless of f_s) then that individual channel is muted if this function is enabled.

6.1.5 Configuration register E (addr 0x04)

D7	D6	D5	D4	D3	D2	D1	D0
SVE	ZCE	DCCV	PWMS	AME	NSBW	MPC	MPCV
1	1	0	0	0	0	1	0

Max power correction variable

Table 25. Max power correction variable

Bit	R/W	RST	Name	Description
0	R/W	0	MPCV	0: use standard MPC coefficient 1: use MPCC bits for MPC coefficient

Max power correction

Table 26. Max power correction

Bit	R/W	RST	Name	Description
1	R/W	1	MPC	1: enable power bridge correction for THD reduction near maximum power output.

Setting the MPC bit turns on special processing that corrects the STA333W power device at high power. This mode lowers the THD+N of a full DDX system at maximum power output and slightly below. If enabled, MPC is operational in all output modes except tapered (OM[1:0] = 01) and binary. When OCFG = 00, MPC does not affect channels 3 and 4, the line-out channels.

Noise-shaper bandwidth selection

Table 27. Noise-shaper bandwidth selection

Bit	R/W	RST	Name	Description
2	R/W	0	NSBW	1: 3 rd order NS 0: 4 th order NS

AM mode enable

Table 28. AM mode enable

Bit	R/W	RST	Name	Description
3	R/W	0	AME	0: normal DDX operation 1: AM reduction mode DDX operation

The STA333W features a DDX processing mode that minimizes the amount of noise generated in frequency range of AM radio. This mode is intended for use when DDX is operating in a device with an AM tuner active. The SNR of the DDX processing is reduced to approximately 83 dB in this mode, which is still greater than the SNR of AM radio.

PWM speed mode

Table 29. PWM speed mode

Bit	R/W	RST	Name	Description
4	R/W	0	PWMS	0: normal speed (384 kHz) all channels 1: odd speed (341.3 kHz) all channels

Distortion compensation variable enable

Table 30. Distortion compensation variable enable

Bit	R/W	RST	Name	Description
5	R/W	0	DCCV	0: uses preset DC coefficient. 1: uses DCC coefficient.

Zero-crossing volume enable**Table 31. Zero-crossing volume enable**

Bit	R/W	RST	Name	Description
6	R/W	1	ZCE	1: volume adjustments will only occur at digital zero-crossings 0: volume adjustments will occur immediately

The ZCE bit enables zero-crossing volume adjustments. When volume is adjusted on digital zero-crossings no clicks will be audible.

Soft volume update enable**Table 32. Zero-crossing volume enable**

Bit	R/W	RST	Name	Description
7	R/W	1	SVE	1: volume adjustments ramp according to SVR settings 0: volume adjustments will occur immediately

6.1.6 Configuration register F (addr 0x05)

D7	D6	D5	D4	D3	D2	D1	D0
EAPD	PWDN	ECLE	LDTE	BCLE	IDE	Reserved	
0	1	0	1	1	1	0	0

Invalid Input detect mute enable**Table 33. Invalid input detect mute enable**

Bit	R/W	RST	Name	Description
2	R/W	1	IDE	1: enables the automatic invalid input detect mute

Setting the IDE bit enables this function, which looks at the input I²S data and will automatically mute if the signals are perceived as invalid.

Binary output mode clock loss detection**Table 34. Binary output mode clock loss detection**

Bit	R/W	RST	Name	Description
3	R/W	1	BCLE	Binary output mode clock loss detection enable

Detects loss of input MCLK in binary mode and outputs 50% of the duty cycle.

LRCK double trigger protection

Table 35. LRCK double trigger protection

Bit	R/W	RST	Name	Description
4	R/W	1	LDTE	LRCLK double trigger protection enable

Actively prevents double trigger of LRCLK.

Auto EAPD on clock loss

Table 36. Auto EAPD on clock loss

Bit	R/W	RST	Name	Description
5	R/W	0	ECLE	Auto EAPD on clock loss

When active will issue a power device power-down signal (EAPD) on clock loss detection.

IC power down

Table 37. Power down

Bit	R/W	RST	Name	Description
6	R/W	1	PWDN	0: power down, low-power condition 1: normal operation

The PWDN register is used to put the IC in a low-power state. When PWDN is 0, the output begins a soft-mute. After the mute condition is reached, EAPD is asserted to power down the power stage, then the master clock to all internal hardware except the I²C block is gated. This puts the IC in a very low power consumption state.

External amplifier power down

Table 38. External amplifier power down

Bit	R/W	RST	Name	Description
7	R/W	1	EAPD	0: external power stage power down active 1: normal operation

The EAPD register directly disables/enables the internal power circuitry.

When EAPD = 0, the internal power section is placed in a low-power state (disabled).

6.2 Volume control registers (addr 0x06 to 0x09)

6.2.1 Mute/line output configuration register (addr 0x06)

D7	D6	D5	D4	D3	D2	D1	D0
Reserved					C2M	C1M	MMUTE
0	0	0	0	0	0	0	0

Master mute

Table 39. Master mute

Bit	R/W	RST	Name	Description
0	R/W	0	MMUTE	0: normal operation 1: all channels are in mute condition

Channel mute

Table 40. Channel mute

Bit	R/W	RST	Name	Description
1	R/W	0	C1M	Channel 1 mute: 0: not muted, it is possible to set the channel volume 1: hardware muted
2	R/W	0	C2M	Channel 2 mute: 0: not muted, it is possible to set the channel volume 1: hardware muted

6.2.2 Master volume register (addr 0x07)

D7	D6	D5	D4	D3	D2	D1	D0
MV7	MV6	MV5	MV4	MV3	MV2	MV1	MV0
1	1	1	1	1	1	1	1

6.2.3 Channel volume (addr 0x08, 0x09)

D7	D6	D5	D4	D3	D2	D1	D0
C1V7	C1V6	C1V5	C1V4	C1V3	C1V2	C1V1	C1V0
0	1	1	0	0	0	0	0

D7	D6	D5	D4	D3	D2	D1	D0
C2V7	C2V6	C2V5	C2V4	C2V3	C2V2	C2V1	C2V0
0	1	1	0	0	0	0	0

Volume setting

The volume structure of the STA333W consists of individual volume registers for each channel and a master volume register that provides an offset to each channels volume setting. The individual channel volumes are adjustable in 0.5-dB steps from +48 dB to -80 dB. As an example if C3V = 0x00 or +48 dB and MV = 0x18 or -12 dB, then the total gain for channel 3 = +36 dB.

The master mute when set to 1 will mute all channels at once, whereas the individual channel mutes (CxM) mute only that channel. Both the master mute and the channel mutes provide a “soft mute” with the volume ramping down to mute in 4096 samples from the maximum volume setting at the internal processing rate (about 96 kHz). A hard mute can be obtained by commanding a value of all 1’s (255) to any channel volume register or the master volume register. When volume offsets are provided via the master volume register any channel that whose total volume is less than -80 dB is muted.

All changes in volume take place at zero-crossings when ZCE = 1 (configuration register F) on a per channel basis as this creates the smoothest possible volume transitions. When ZCE = 0, volume updates will occur immediately.

Table 41. Master volume offset as a function of MV

MV[7:0]	Volume offset from channel value
00000000 (0x00)	0 dB
00000001 (0x01)	-0.5 dB
00000010 (0x02)	-1 dB
...	...
01001100 (0x4C)	-38 dB
...	...
11111110 (0xFE)	-127.5 dB
11111111 (0xFF)	Hard master mute

Table 42. Channel volume as a function of CxV

CxV[7:0]	Volume
00000000 (0x00)	+48 dB
00000001 (0x01)	+47.5 dB
00000010 (0x02)	+47 dB
...	...
01011111 (0x5F)	+0.5 dB
01100000 (0x60)	0 dB
01100001 (0x61)	-0.5 dB
...	...
11010111 (0xD7)	-59.5 dB
11011000 (0xD8)	-60 dB
11011001 (0xD9)	-61 dB
11011010 (0xDA)	-62 dB
...	...
11101100 (0xEC)	-80 dB
11101101 (0xED)	Hard channel mute
...	...
11111111 (0xFF)	Hard channel mute

6.3 Automodes™ register (0x0C)

D7	D6	D5	D4	D3	D2	D1	D0
Reserved				AMAM2	AMAM1	AMAM0	AMAME
0	0	0	0	0	0	0	0

AM interference frequency switching

Table 43. AM interference frequency switching

Bit	R/W	RST	Name	Description
0	R/W	0	AMAME	0: switching frequency determined by PWMS setting 1: switching frequency determined by AMAM setting

AMAM bits

Table 44. Automodes™ AM switching frequency selection

AMAM[2:0]	48 kHz / 96 kHz input f _S	44.1 kHz / 88.2 kHz input f _S
000	0.535 MHz - 0.720 MHz	0.535 MHz - 0.670 MHz
001	0.721 MHz - 0.900 MHz	0.671 MHz - 0.800 MHz

Table 44. Automodes™ AM switching frequency selection

010	0.901 MHz - 1.100 MHz	0.801 MHz - 1.000 MHz
011	1.101 MHz - 1.300 MHz	1.001 MHz - 1.180 MHz
100	1.301 MHz - 1.480 MHz	1.181 MHz - 1.340 MHz
101	1.481 MHz - 1.600 MHz	1.341 MHz - 1.500 MHz
110	1.601 MHz - 1.700 MHz	1.501 MHz - 1.700 MHz

6.4 Channel configuration registers (addr 0x0E, 0x0F)

D7	D6	D5	D4	D3	D2	D1	D0
Reserved					C1VBP	Reserved	
0	0	0	0	0	0	0	0

D7	D6	D5	D4	D3	D2	D1	D0
Reserved					C2VBP	Reserved	
0	0	0	0	0	0	0	0

Volume bypass

Each channel contains an individual channel volume bypass. If a particular channel has volume bypassed via the CxVBP = 1 register then only the channel volume setting for that particular channel affects the volume setting, the master volume setting will not affect that channel.

6.5 Variable max power correction registers (addr 0x27, 0x28)

MPCC bits determine the 16 MSBs of the MPC compensation coefficient. This coefficient is used in place of the default coefficient when MPCV = 1.

D7	D6	D5	D4	D3	D2	D1	D0
MPCC15	MPCC14	MPCC13	MPCC12	MPCC11	MPCC10	MPCC9	MPCC8
0	0	0	1	1	0	1	0

D7	D6	D5	D4	D3	D2	D1	D0
MPCC7	MPCC6	MPCC5	MPCC4	MPCC3	MPCC2	MPCC1	MPCC0
1	1	0	0	0	0	0	0

6.6 Variable distortion compensation registers (addr 0x29, 0x2A)

D7	D6	D5	D4	D3	D2	D1	D0
DCC15	DCC14	DCC13	DCC12	DCC11	DCC10	DCC9	DCC8
1	1	1	1	0	0	1	1

D7	D6	D5	D4	D3	D2	D1	D0
DCC7	DCC6	DCC5	DCC4	DCC3	DCC2	DCC1	DCC0
0	0	1	1	0	0	1	1

DCC bits determine the 16 MSBs of the distortion compensation coefficient. This coefficient is used in place of the default coefficient when DCCV = 1.

6.7 Fault detect recovery constant registers (addr 0x2B, 0x2C)

D7	D6	D5	D4	D3	D2	D1	D0
FDRC15	FDRC14	FDRC13	FDRC12	FDRC11	FDRC10	FDRC9	FDRC8
0	0	0	0	0	0	0	0

D7	D6	D5	D4	D3	D2	D1	D0
FDRC7	FDRC6	FDRC5	FDRC4	FDRC3	FDRC2	FDRC1	FDRC0
0	0	0	0	1	1	0	0

FDRC bits specify the 16-bit fault detect recovery time delay. When status register bit FAULT is asserted, the tristate output is immediately asserted low and held low for the time period specified by this constant. A value of 0x0001 in this register is approximately 0.083 ms. The default value of 0x000C gives approximately 0.1 ms.

Note: 0x0000 is a reserved value for this register pair. This value must not be used.

6.8 Device status register (addr 0x2D)

D7	D6	D5	D4	D3	D2	D1	D0
PLLUL	FAULT	UVFAULT	Reserved	OCFAULT	OCWARN	TFAULT	TWARN

This read-only register provides the fault, warning and PLL status from the power control block.

Table 45. Status bits description

Bit	R/W	RST	Name	Description
0	RO	-	TWARN	Thermal warning: 0: junction temperature is close to the fault condition 1: normal operation
1	RO	-	TFAULT	Thermal fault: 0: junction temperature limit detection 1: normal operation

Table 45. Status bits description (continued)

Bit	R/W	RST	Name	Description
2	RO	-	OCWARN	Overcurrent warning: 0: warning 1: normal operation
3	RO	-	OCFAULT	Overcurrent fault: 0: fault detected 1: normal operation
4	-	-	-	Reserved
5	RO	-	UVFAULT	Undervoltage warning: 0: VCCx below lower voltage threshold 1: normal operation
6	RO	-	FAULT	Power bridge fault: 0: fault detected 1: normal operation
7	RO	-	PLLUL	PLL lock: 0: locked 1: not locked

6.9 Reserved registers (addr 0x2E, 0x2F, 0x30, 0x31)

These registers are not to be used.

6.10 Postscale registers (addr 0x32, 0x33)

D7	D6	D5	D4	D3	D2	D1	D0
C1PS7	C1PS6	C1PS5	C1PS4	C1PS3	C1PS2	C1PS1	C1PS0
0	1	1	1	1	1	1	1

D7	D6	D5	D4	D3	D2	D1	D0
C2PS7	C2PS6	C2PS5	C2PS4	C2PS3	C2PS2	C2PS1	C2PS0
0	1	1	1	1	1	1	1

Postscale

The STA333W provides one additional multiplication after the last interpolation stage and the distortion compensation on each channel, which can be used to limit the maximum modulation index and therefore the peak current through the power device. The register values represent an 8-bit signed fractional number. This number is extended to a 24-bit number, by adding zeros to the right, and then directly multiplied by the data on that channel. An independent postscale is provided for each channel but all channels can use channel 1 postscale factor by setting the postscale link bit. By default, all postscale factors are set to 0x7F (pass-through).

6.11 Output limit register (addr 0x34)

6.11.1 Thermal and overcurrent warning output limit register

D7	D6	D5	D4	D3	D2	D1	D0
OLIM7	OLIM6	OLIM5	OLIM4	OLIM3	OLIM2	OLIM1	OLIM0
0	1	0	1	1	0	1	0

The STA333W provides a simple mechanism for reacting to a thermal or overcurrent warning in the power device. When the TWARN or OCWARN status bit is asserted, the output is limited to the OLIM setting. The limit can be adjusted by modifying the thermal warning/overcurrent output limit value. As for the normal postscale, the register value represents an 8-bit signed fractional number. This number is extended to a 24-bit number, by adding zeros to the right, and then directly multiplied by the data on both channels. The scaling value range is from $0x80 = -1$ to $0x7F = 0.992$. To avoid phase changes in the output signal only the positive range is used ($0x00$ to $0x7F$). The default setting of $0x5A$ provides a -3-dB limit.

If the cause of the limiting is a thermal warning, the output limiting is removed when the thermal warning situation disappears. If the cause of the limiting is an overcurrent warning, output limiting remains in effect until the device is reset.

Table 46. Output limit values for thermal and overcurrent warnings

OLIM[7:0]	Attenuation (dB)
0x7F	0.06
0x7E	0.13
....
0x5A	3.0
....
0x40	6.0
....
0x28	10
....
0x01	42
0x00	Inf

7 Applications information

7.1 Applications scheme for power supplies

Figure 11 below shows a typical applications scheme for STA333W.

Special care has to be taken with regard to the power supplies when laying out the PCB. In particular the 3.3-Ω resistors on the digital supplies (VDD_DIG) have to be placed as close as possible to the device. This prevents unwanted oscillation on the digital parts of the device due to the inductive effects of the PCB tracks. The same rule also applies to all the decoupling capacitors; they should be placed as close as possible to the device in order to limit the effect of spikes on the supplies.

Figure 11. Applications diagram

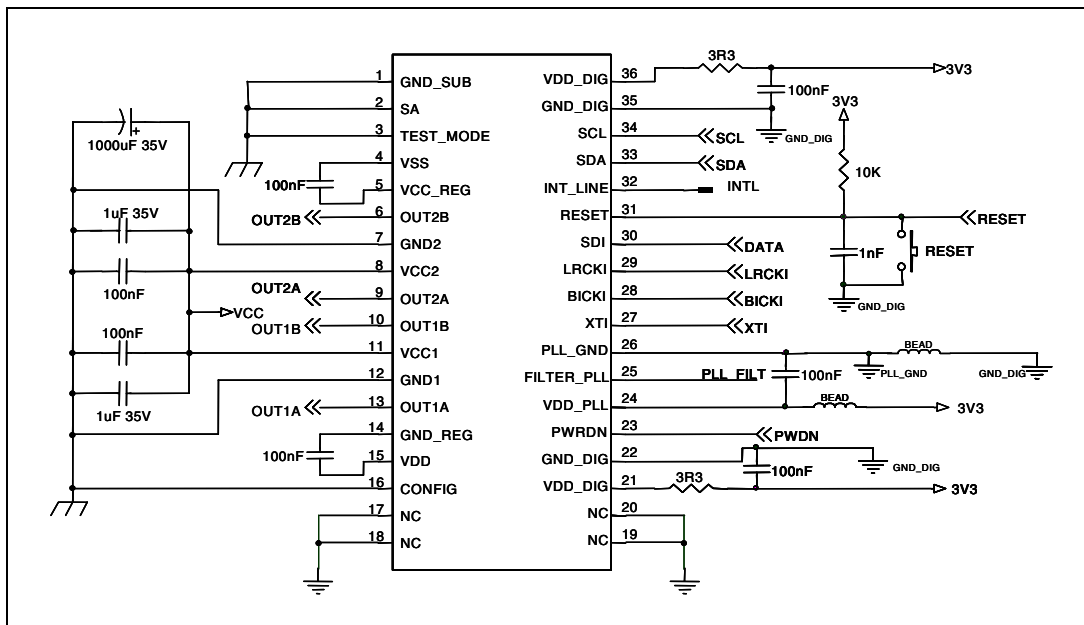

7.2 PLL filter

It is recommended to use the circuit in Figure 12 below for the PLL loop filter to achieve the best performance from the device in general applications. Note that the ground of this filter has to be connected to the ground of the PLL without any resistive path.

For the component values, it should be remembered that the greater the filter bandwidth, the shorter the lock time but the higher the PLL output jitter.

Figure 12. PLL filter circuit

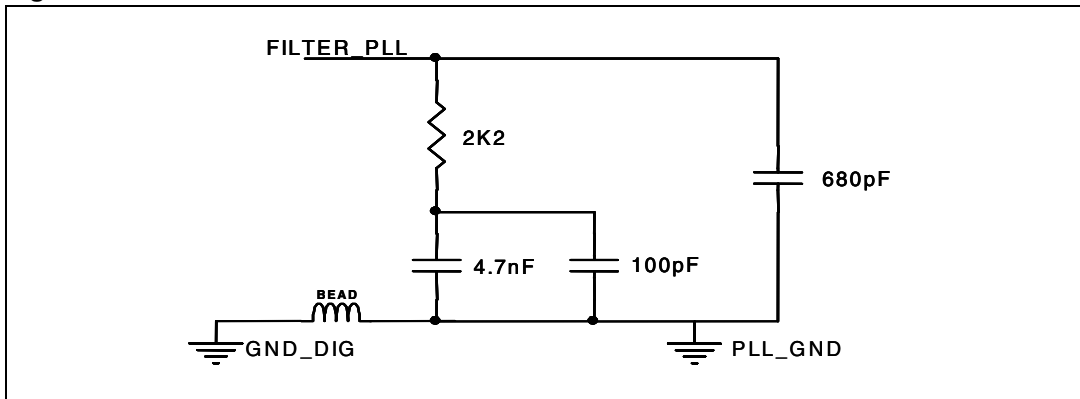

7.3 Typical output configuration

Figure 13 below shows a typical output configuration used for BTL stereo mode.

Figure 13. Output configuration for stereo BTL mode

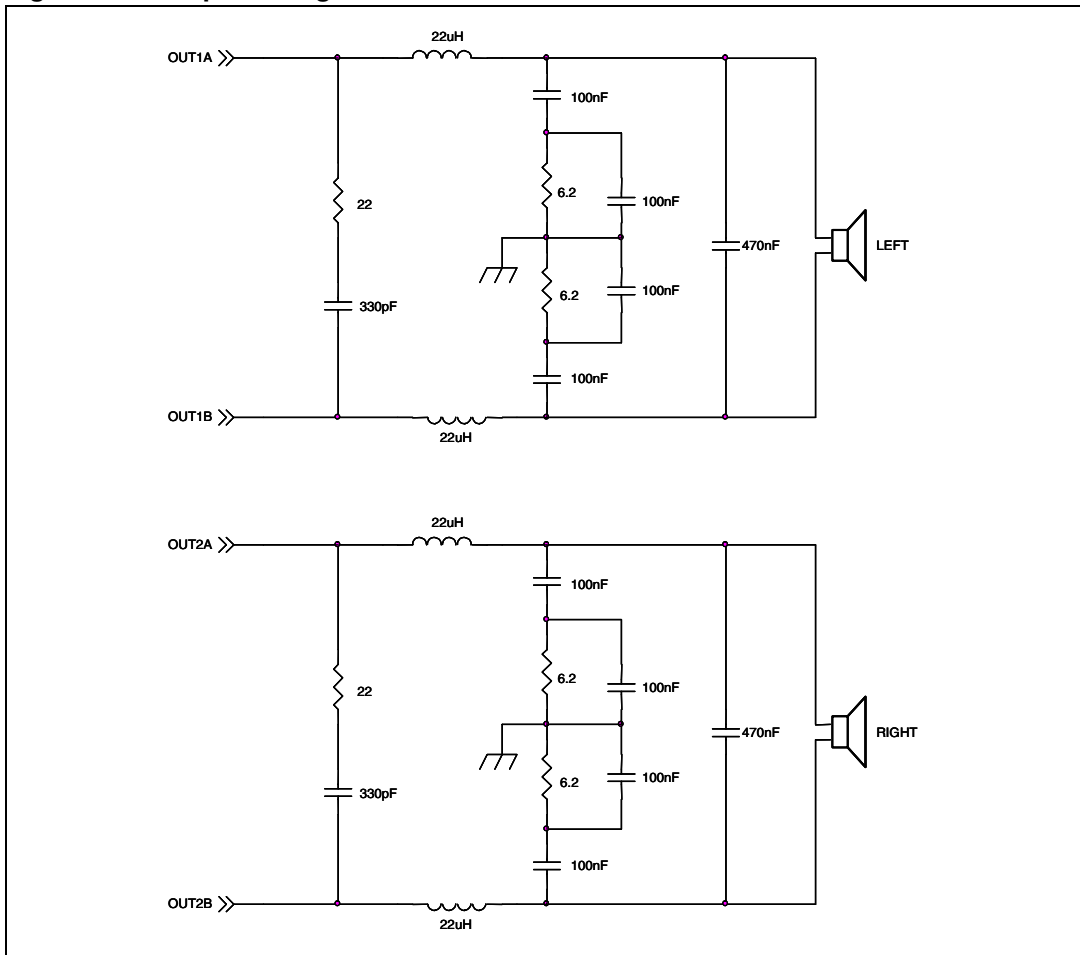

8 Characterization data

The following characterizations were made with $R_L = 8 \Omega$ and $f = 1 \text{ kHz}$ unless otherwise stated.

Figure 14. Output power vs. supply voltage (THD = 1%)

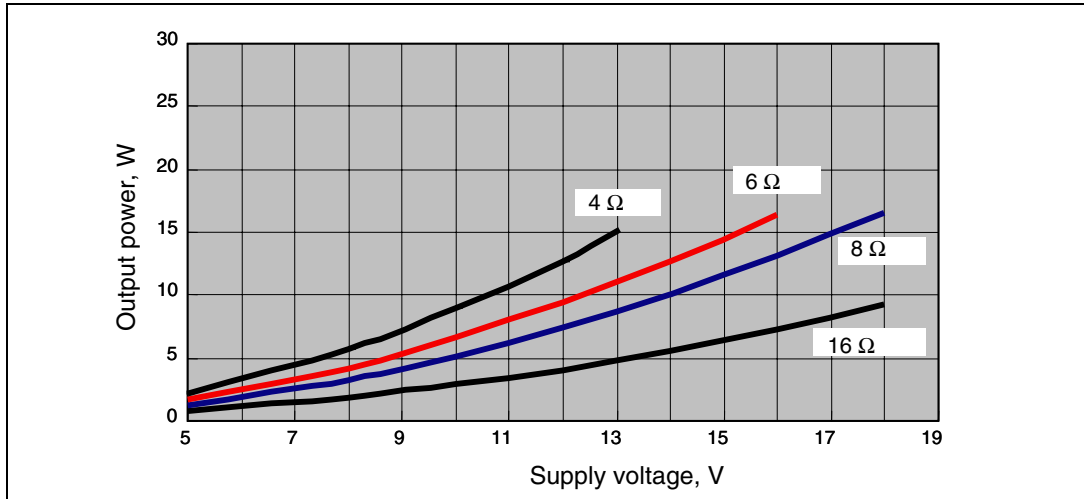

Figure 15. FFT 0 dBfs ($V_{CC} = 12 \text{ V}$)

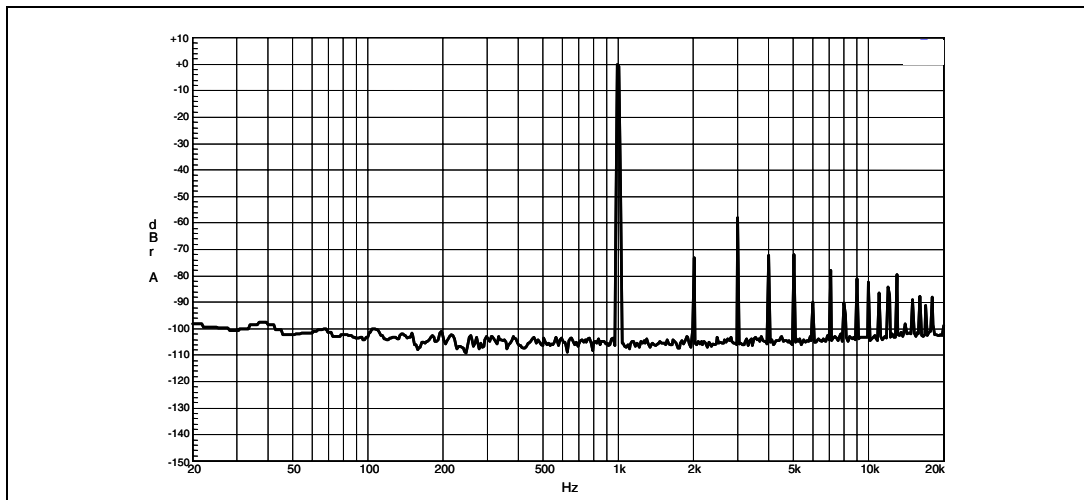

Figure 16. FFT -60 dBfs ($V_{CC} = 12\text{ V}$)

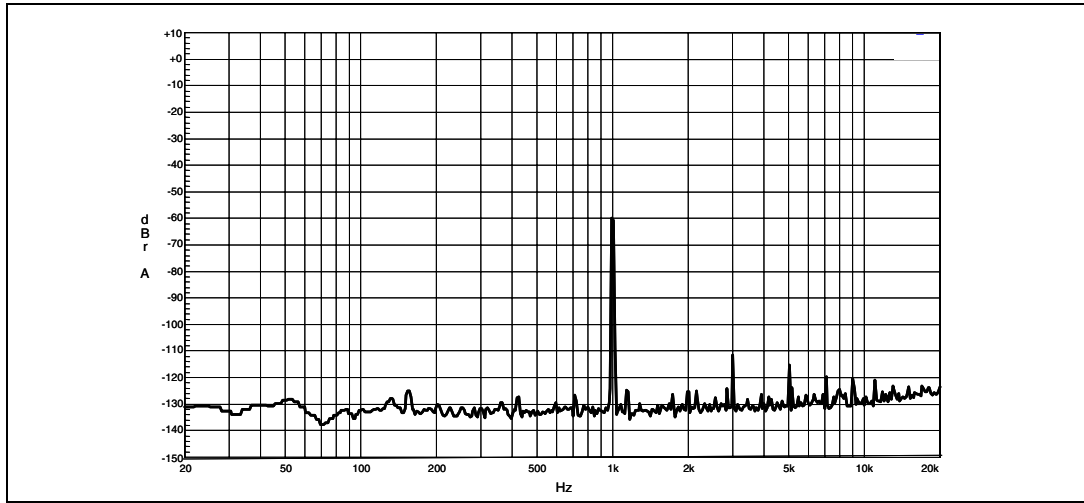

Figure 17. THD vs. frequency ($V_{CC} = 12\text{ V}$, $P_o = 1\text{ W}$)

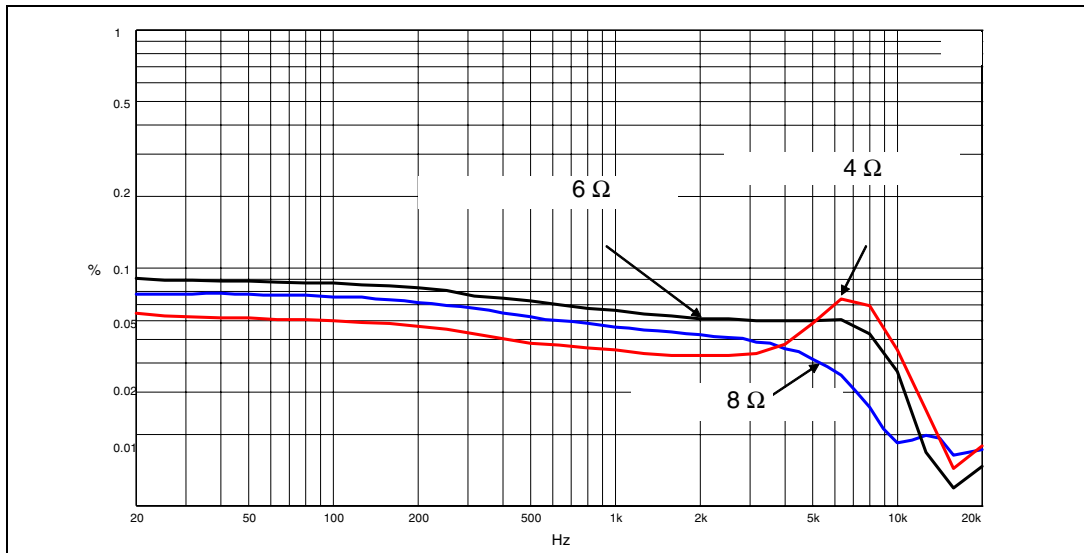

Figure 18. FFT 0 dBfs ($V_{CC} = 18\text{ V}$)

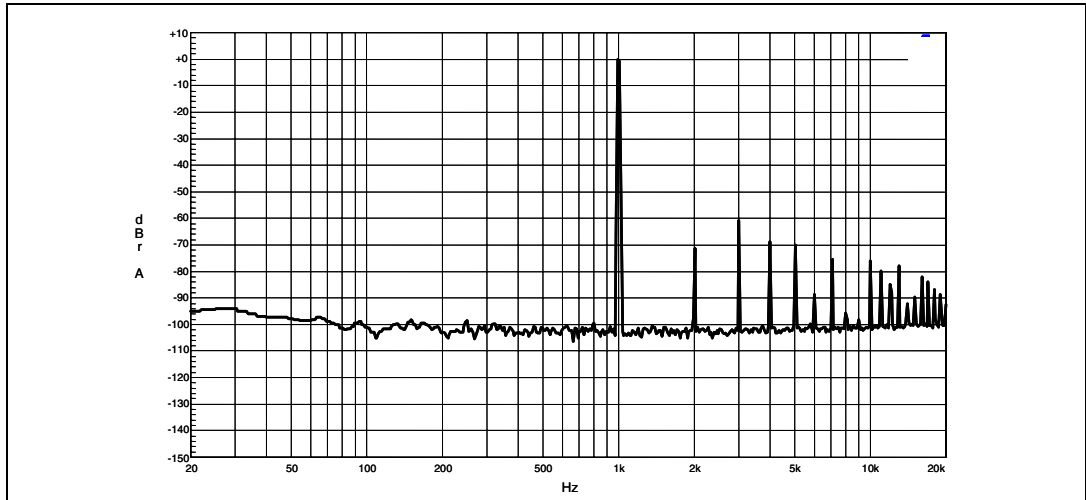

Figure 19. FFT -60 dBfs ($V_{CC} = 18\text{ V}$)

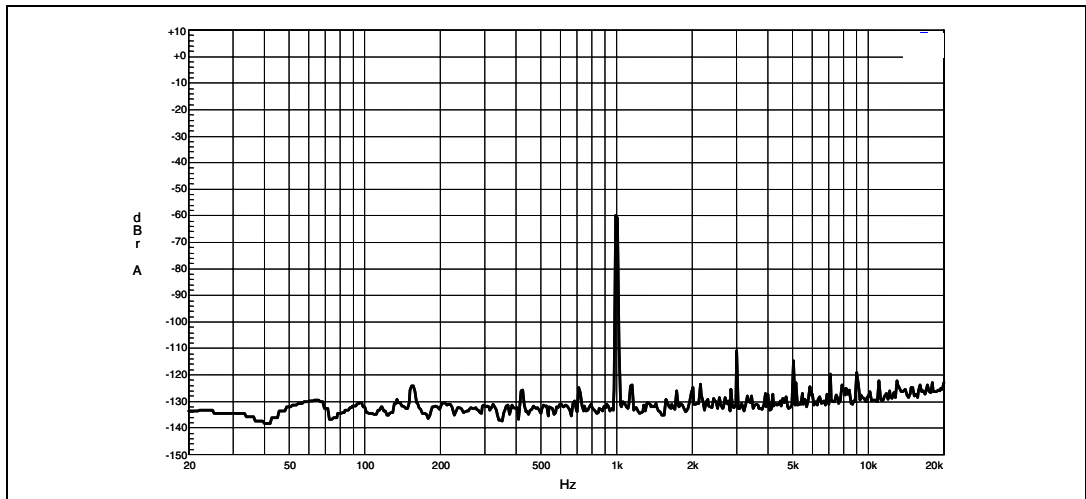
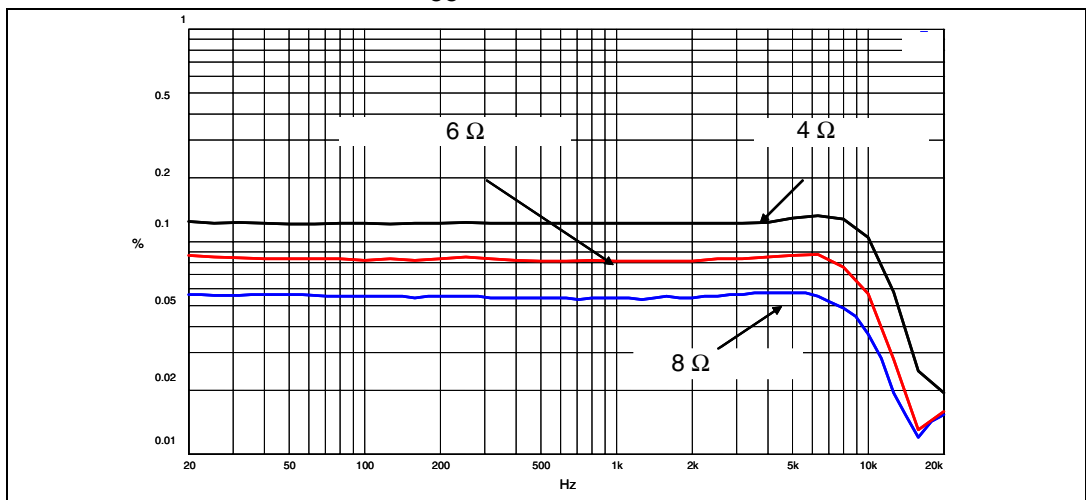

Figure 20. THD vs. frequency ($V_{CC} = 18\text{ V}$, $P_o = 1\text{ W}$)



9 Package thermal characteristics

A thermal resistance of 25 °C/W can be achieved by mounting the device on a PCB which has two copper ground areas of 3 x 3 cm and 16 vias (see [Figure 21](#)).

Given that the amount of power dissipated within the device depends primarily on the supply voltage, load impedance and output modulation level the maximum estimated dissipated power for the STA333W is 3 W.

With the above suggested board as heatsink, a maximum junction temperature rise, ΔT_j , of 75 °C is possible. In consumer environments where 50 °C is the maximum ambient temperature this provides some safety margin before the intervention of the thermal protection ($T_j = 150$ °C).

Figure 21. Double-layer PCB with two copper ground areas and 16 vias

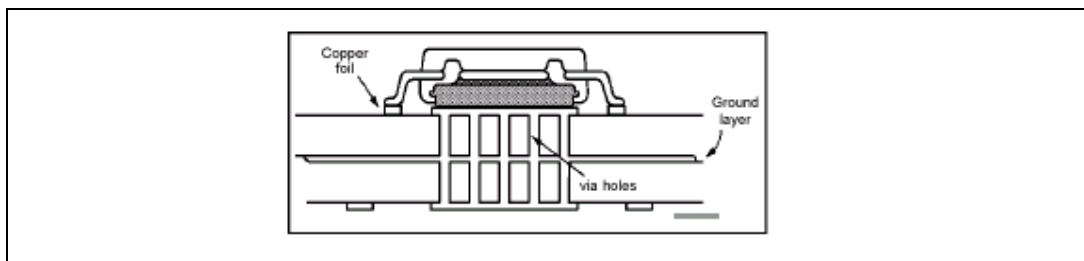

[Figure 22](#) shows the power derating curve for the PowerSSO-36 package on PCBs with copper areas of 2 x 2 cm² and 3 x 3 cm².

Figure 22. Power derating curve for PCB used as heatsink

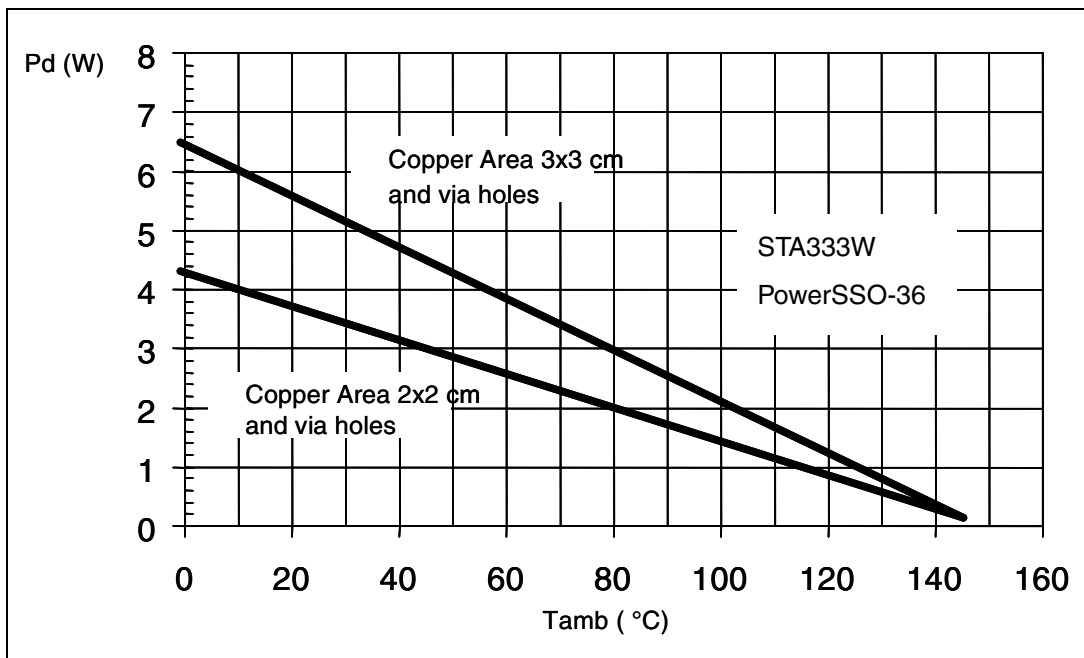

10 Package mechanical data

The STA333W comes in a 36-pin PowerSSO package with exposed pad down (EPD). [Figure 23](#) below shows the package outline and [Table 47](#) gives the dimensions.

Figure 23. PowerSSO-36 EPD outline drawing

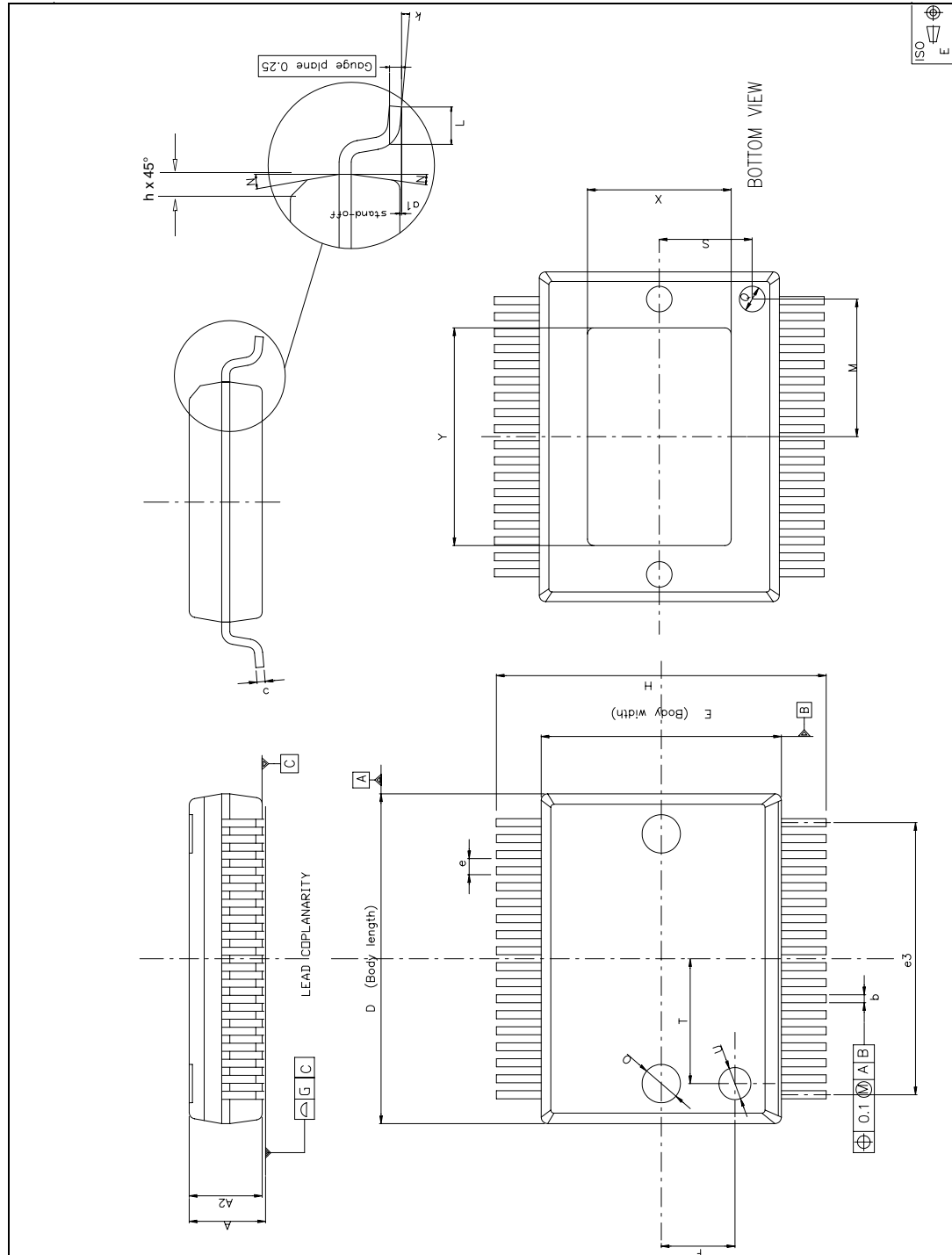

Table 47. PowerSSO-36 EPD dimensions

Symbol	Dimensions in mm			Dimensions in inches		
	Min	Typ	Max	Min	Typ	Max
A	2.15	-	2.47	0.085	-	0.097
A2	2.15	-	2.40	0.085	-	0.094
a1	0.00	-	0.10	0.000	-	0.004
b	0.18	-	0.36	0.007	-	0.014
c	0.23	-	0.32	0.009	-	0.013
D	10.10	-	10.50	0.398	-	0.413
E	7.40	-	7.60	0.291	-	0.299
e	-	0.5	-	-	0.020	-
e3	-	8.5	-	-	0.335	-
F	-	2.3	-	-	0.091	-
G	-	-	0.10	-	-	0.004
H	10.10	-	10.50	0.398	-	0.413
h	-	-	0.40	-	-	0.016
k	0	-	8 degrees	0	-	8 degrees
L	0.60	-	1.00	0.024	-	0.039
M	-	4.30	-	-	0.169	-
N	-	-	10 degrees	-	-	10 degrees
O	-	1.20	-	-	0.047	-
Q	-	0.80	-	-	0.031	-
S	-	2.90	-	-	0.114	-
T	-	3.65	-	-	0.144	-
U	-	1.00	-	-	0.039	-
X	4.10	-	4.70	0.161	-	0.185
Y	4.90	-	7.10	0.193	-	0.280

In order to meet environmental requirements, ST offers these devices in different grades of ECOPACK[®] packages, depending on their level of environmental compliance. ECOPACK[®] specifications, grade definitions and product status are available at: www.st.com. ECOPACK[®] is an ST trademark.

11 Trademarks and other acknowledgements

DDX is a registered trademark of Apogee Technology Inc.

Automodes is a trademark of Apogee Technology Inc.

ECOPACK is a registered trademark of STMicroelectronics.

Sound Terminal is a trademark of STMicroelectronics.

12 Revision history

Table 48. Document revision history

Date	Revision	Changes
25-May-2007	1	Initial release.
21-Jan-2010	2	<p>Updated features for operating voltage range, digital gain increments and maximum power control on page 1</p> <p>Updated description on page 1</p> <p>Updated electrical specifications Table 4, Table 3 and Table 5 on page 11</p> <p>Added Section 3.3: Electrical specifications - digital section on page 12</p> <p>Added chapter Functional description on page 16</p> <p>Updated usage of pin name SDA in first paragraph of Chapter 5: I²C bus specification on page 18</p> <p>Added Section 5.4: Read operation on page 19</p> <p>Removed PSL (register add 0x03) in Table 8: Register summary on page 21</p> <p>Updated text concerning overcurrent warning for register CONF_C on page 27</p> <p>Removed bit PSL in Configuration register D (addr 0x03) on page 28</p> <p>Corrected reset value for register bit MPCV in Table 25 on page 28</p> <p>Updated bit names and added register description table in Device status register (addr 0x2D) on page 36</p> <p>Updated text and added OLIM attenuation table in Output limit register (addr 0x34) on page 38</p> <p>Deleted mention of appsnote in Section 7.3 on page 40</p> <p>Updated package Y (Min) dimension in Table 47 on page 46</p> <p>Removed references to STA50x/51x throughout the document</p>

Please Read Carefully:

Information in this document is provided solely in connection with ST products. STMicroelectronics NV and its subsidiaries ("ST") reserve the right to make changes, corrections, modifications or improvements, to this document, and the products and services described herein at any time, without notice.

All ST products are sold pursuant to ST's terms and conditions of sale.

Purchasers are solely responsible for the choice, selection and use of the ST products and services described herein, and ST assumes no liability whatsoever relating to the choice, selection or use of the ST products and services described herein.

No license, express or implied, by estoppel or otherwise, to any intellectual property rights is granted under this document. If any part of this document refers to any third party products or services it shall not be deemed a license grant by ST for the use of such third party products or services, or any intellectual property contained therein or considered as a warranty covering the use in any manner whatsoever of such third party products or services or any intellectual property contained therein.

UNLESS OTHERWISE SET FORTH IN ST'S TERMS AND CONDITIONS OF SALE ST DISCLAIMS ANY EXPRESS OR IMPLIED WARRANTY WITH RESPECT TO THE USE AND/OR SALE OF ST PRODUCTS INCLUDING WITHOUT LIMITATION IMPLIED WARRANTIES OF MERCHANTABILITY, FITNESS FOR A PARTICULAR PURPOSE (AND THEIR EQUIVALENTS UNDER THE LAWS OF ANY JURISDICTION), OR INFRINGEMENT OF ANY PATENT, COPYRIGHT OR OTHER INTELLECTUAL PROPERTY RIGHT.

UNLESS EXPRESSLY APPROVED IN WRITING BY AN AUTHORIZED ST REPRESENTATIVE, ST PRODUCTS ARE NOT RECOMMENDED, AUTHORIZED OR WARRANTED FOR USE IN MILITARY, AIR CRAFT, SPACE, LIFE SAVING, OR LIFE SUSTAINING APPLICATIONS, NOR IN PRODUCTS OR SYSTEMS WHERE FAILURE OR MALFUNCTION MAY RESULT IN PERSONAL INJURY, DEATH, OR SEVERE PROPERTY OR ENVIRONMENTAL DAMAGE. ST PRODUCTS WHICH ARE NOT SPECIFIED AS "AUTOMOTIVE GRADE" MAY ONLY BE USED IN AUTOMOTIVE APPLICATIONS AT USER'S OWN RISK.

Resale of ST products with provisions different from the statements and/or technical features set forth in this document shall immediately void any warranty granted by ST for the ST product or service described herein and shall not create or extend in any manner whatsoever, any liability of ST.

ST and the ST logo are trademarks or registered trademarks of ST in various countries.

Information in this document supersedes and replaces all information previously supplied.

The ST logo is a registered trademark of STMicroelectronics. All other names are the property of their respective owners.

© 2010 STMicroelectronics - All rights reserved

STMicroelectronics group of companies

Australia - Belgium - Brazil - Canada - China - Czech Republic - Finland - France - Germany - Hong Kong - India - Israel - Italy - Japan - Malaysia - Malta - Morocco - Philippines - Singapore - Spain - Sweden - Switzerland - United Kingdom - United States of America

www.st.com

