



STM32F102x8 STM32F102xB

Medium-density USB access line, ARM-based 32-bit MCU with 64/128KB Flash, USB FS interface, 6 timers, ADC & 8 communication interfaces

Features

- Core: ARM 32-bit Cortex™-M3 CPU
 - 48 MHz maximum frequency, 1.25 DMIPS/MHz (Dhrystone 2.1) performance at 0 WS memory access
 - Single-cycle multiplication and hardware division
- Memories
 - 64 or 128 Kbytes of Flash memory
 - 10 or 16 Kbytes of SRAM
- Clock, reset and supply management
 - 2.0 to 3.6 V application supply and I/Os
 - POR, PDR and programmable voltage detector (PVD)
 - 4-to-16 MHz crystal oscillator
 - Internal 8 MHz factory-trimmed RC
 - Internal 40 kHz RC
 - PLL for CPU clock
 - 32 kHz oscillator for RTC with calibration
- Low power
 - Sleep, Stop and Standby modes
 - V_{BAT} supply for RTC and backup registers
- Debug mode
 - Serial wire debug (SWD) and JTAG interfaces
- DMA
 - 7-channel DMA controller
 - Peripherals supported: timers, ADC, SPIs, I²Cs and USARTs
- 1 × 12-bit, 1.2 μs A/D converter (up to 16 channels)
 - Conversion range: 0 to 3.6 V
 - Temperature sensor
- Up to 51 fast I/O ports
 - 37/51 IOs all mappable on 16 external interrupt vectors and almost all 5 V-tolerant

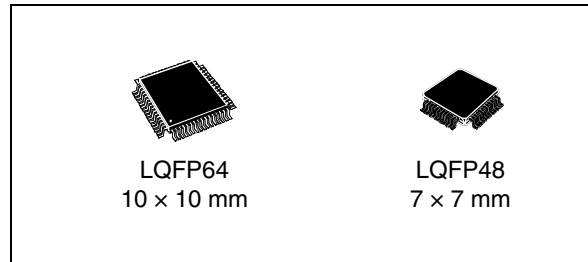

- Up to 6 timers
 - Three 16-bit timers, each with up to 4 IC/OC/PWM or pulse counter
 - 2 watchdog timers (Independent and Window)
 - SysTick timer: 24-bit downcounter
- Up to 8 communication interfaces
 - Up to 2 × I²C interfaces (SMBus/PMBus)
 - Up to 3 USARTs (ISO 7816 interface, LIN, IrDA capability, modem control)
 - Up to 2 SPIs (12 Mbit/s)
 - USB 2.0 full speed interface
- CRC calculation unit, 96-bit unique ID
- ECOPACK® packages

Table 1. Device summary

Reference	Part number
STM32F102x8	STM32F102C8, STM32F102R8
STM32F102xB	STM32F102CB, STM32F102RB

Contents

1	Introduction	7
2	Description	8
2.1	Device overview	9
2.2	Full compatibility throughout the family	10
2.3	Overview	10
3	Pinouts and pin description	18
4	Memory mapping	22
5	Electrical characteristics	23
5.1	Parameter conditions	23
5.1.1	Minimum and maximum values	23
5.1.2	Typical values	23
5.1.3	Typical curves	23
5.1.4	Loading capacitor	23
5.1.5	Pin input voltage	23
5.1.6	Power supply scheme	24
5.1.7	Current consumption measurement	25
5.2	Absolute maximum ratings	25
5.3	Operating conditions	27
5.3.1	General operating conditions	27
5.3.2	Operating conditions at power-up / power-down	27
5.3.3	Embedded reset and power control block characteristics	28
5.3.4	Embedded reference voltage	28
5.3.5	Supply current characteristics	29
5.3.6	External clock source characteristics	38
5.3.7	Internal clock source characteristics	42
5.3.8	PLL characteristics	43
5.3.9	Memory characteristics	44
5.3.10	EMC characteristics	44
5.3.11	Absolute maximum ratings (electrical sensitivity)	46
5.3.12	I/O port characteristics	46

5.3.13	NRST pin characteristics	50
5.3.14	TIM timer characteristics	51
5.3.15	Communications interfaces	51
5.3.16	12-bit ADC characteristics	57
5.3.17	Temperature sensor characteristics	61
6	Package characteristics	62
6.1	Package mechanical data	62
6.2	Thermal characteristics	65
6.3	Reference document	65
6.3.1	Evaluating the maximum junction temperature for an application	66
7	Ordering information scheme	67
8	Revision history	68

List of tables

Table 1.	Device summary	1
Table 2.	STM32F102x8 and STM32F102xB medium-density USB access line features and peripheral counts	9
Table 3.	STM32F102xx USB access line family	10
Table 4.	Medium-density STM32F102xx pin definitions	19
Table 5.	Voltage characteristics	25
Table 6.	Current characteristics	26
Table 7.	Thermal characteristics	26
Table 8.	General operating conditions	27
Table 9.	Operating conditions at power-up / power-down	27
Table 10.	Embedded reset and power control block characteristics	28
Table 11.	Embedded internal reference voltage	29
Table 12.	Maximum current consumption in Run mode, code with data processing running from Flash	30
Table 13.	Maximum current consumption in Run mode, code with data processing running from RAM	30
Table 14.	Maximum current consumption in Sleep mode, code running from Flash or RAM	32
Table 15.	Typical and maximum current consumptions in Stop and Standby modes	32
Table 16.	Typical current consumption in Run mode, code with data processing running from Flash	35
Table 17.	Typical current consumption in Sleep mode, code running from Flash or RAM	36
Table 18.	Peripheral current consumption	37
Table 19.	High-speed external user clock characteristics	38
Table 20.	Low-speed external user clock characteristics	38
Table 21.	HSE 4-16 MHz oscillator characteristics	40
Table 22.	LSE oscillator characteristics ($f_{LSE} = 32.768$ kHz)	41
Table 23.	HSI oscillator characteristics	42
Table 24.	LSI oscillator characteristics	42
Table 25.	Low-power mode wakeup timings	43
Table 26.	PLL characteristics	43
Table 27.	Flash memory characteristics	44
Table 28.	Flash memory endurance and data retention	44
Table 29.	EMS characteristics	45
Table 30.	EMI characteristics	45
Table 31.	ESD absolute maximum ratings	46
Table 32.	Electrical sensitivities	46
Table 33.	I/O static characteristics	47
Table 34.	Output voltage characteristics	48
Table 35.	I/O AC characteristics	49
Table 36.	NRST pin characteristics	50
Table 37.	TIMx characteristics	51
Table 38.	I ² C characteristics	52
Table 39.	SCL frequency ($f_{PCLK1} = 24$ MHz, $V_{DD} = 3.3$ V)	53
Table 40.	SPI characteristics	54
Table 41.	USB startup time	56
Table 42.	USB DC electrical characteristics	57
Table 43.	USB: Full speed electrical characteristics of the driver	57
Table 44.	ADC characteristics	58

Table 45.	R_{AIN} max for $f_{ADC} = 12$ MHz	59
Table 46.	ADC accuracy - limited test conditions	59
Table 47.	ADC accuracy	59
Table 48.	TS characteristics	61
Table 49.	LQFP64 – 64-pin low-profile quad flat package mechanical data	63
Table 50.	LQFP48 – 48-pin low-profile quad flat package mechanical data	64
Table 51.	Package thermal characteristics	65
Table 52.	Ordering information scheme	67
Table 53.	Document revision history	68

List of figures

Figure 1.	STM32F102xx medium-density USB access line block diagram	16
Figure 2.	Clock tree	17
Figure 3.	STM32F102xx medium-density USB access line LQFP48 pinout	18
Figure 4.	STM32F102xx medium-density USB access line LQFP64 pinout	18
Figure 5.	Memory map	22
Figure 6.	Pin loading conditions	24
Figure 7.	Pin input voltage	24
Figure 8.	Power supply scheme	24
Figure 9.	Current consumption measurement scheme	25
Figure 10.	Typical current consumption in Run mode versus temperature (at 3.6 V) - code with data processing running from RAM, peripherals enabled.	31
Figure 11.	Typical current consumption in Run mode versus temperature (at 3.6 V) - code with data processing running from RAM, peripherals disabled	31
Figure 12.	Typical current consumption in Stop mode with regulator in Run mode versus temperature at $V_{DD} = 3.3\text{ V}$ and 3.6 V	33
Figure 13.	Typical current consumption in Stop mode with regulator in Low-power mode versus temperature at $V_{DD} = 3.3\text{ V}$ and 3.6 V	33
Figure 14.	Typical current consumption in Standby mode versus temperature at $V_{DD} = 3.3\text{ V}$ and 3.6 V	34
Figure 15.	High-speed external clock source AC timing diagram	39
Figure 16.	Low-speed external clock source AC timing diagram	39
Figure 17.	Typical application with an 8 MHz crystal	40
Figure 18.	Typical application with a 32.768 kHz crystal	42
Figure 19.	I/O AC characteristics definition	50
Figure 20.	Recommended NRST pin protection	50
Figure 21.	I ² C bus AC waveforms and measurement circuit ⁽¹⁾	53
Figure 22.	SPI timing diagram - slave mode and CPHA=0	55
Figure 23.	SPI timing diagram - slave mode and CPHA=1 ⁽¹⁾	55
Figure 24.	SPI timing diagram - master mode ⁽¹⁾	56
Figure 25.	USB timings: definition of data signal rise and fall time	57
Figure 26.	ADC accuracy characteristics	60
Figure 27.	Typical connection diagram using the ADC	60
Figure 28.	Power supply and reference decoupling	61
Figure 29.	LQFP64 – 64 pin low-profile quad flat package outline	63
Figure 30.	Recommended footprint ⁽¹⁾	63
Figure 31.	LQFP48 – 48-pin low-profile quad flat package outline	64
Figure 32.	Recommended footprint ⁽¹⁾	64
Figure 33.	LQFP64 P_D max vs. T_A	66

1 Introduction

This datasheet provides the ordering information and mechanical device characteristics of the STM32F102x4 and STM32F102x6 medium-density USB access line microcontrollers. For more details on the whole STMicroelectronics STM32F102xx family, please refer to [Section 2.2: Full compatibility throughout the family](#).

The medium-density STM32F102xx datasheet should be read in conjunction with the low-, medium- and high-density STM32F10xxx reference manual.

For information on programming, erasing and protection of the internal Flash memory please refer to the *STM32F10xxx Flash programming manual*.

The reference and Flash programming manuals are both available from the STMicroelectronics website www.st.com.

For information on the Cortex™-M3 core please refer to the Cortex™-M3 Technical Reference Manual, available from the www.arm.com website at the following address: <http://infocenter.arm.com/help/index.jsp?topic=/com.arm.doc.ddi0337e/>.



2 Description

The STM32F102xx medium-density USB access line incorporates the high-performance ARM Cortex™-M3 32-bit RISC core operating at a 48 MHz frequency, high-speed embedded memories (Flash memory of 64 or 128 Kbytes and SRAM of 10 or 16 Kbytes), and an extensive range of enhanced peripherals and I/Os connected to two APB buses. All devices offer standard communication interfaces (two I²Cs, two SPIs, one USB and three USARTs), one 12-bit ADC and three general-purpose 16-bit timers.

The STM32F102xx family operates in the –40 to +85 °C temperature range, from a 2.0 to 3.6 V power supply. A comprehensive set of power-saving mode allows the design of low-power applications.

The STM32F102xx medium-density USB access line is delivered in the LQFP48 7 × 7 mm and LQFP64 10 × 10 mm packages.

The STM32F102xx medium-density USB access line microcontrollers are suitable for a wide range of applications:

- Application control and user interface
- Medical and handheld equipment
- PC peripherals, gaming and GPS platforms
- Industrial applications: PLC, inverters, printers, and scanners
- Alarm systems, Video intercom, and HVAC

Figure 1 shows the general block diagram of the device family.

2.1 Device overview

Table 2. STM32F102x8 and STM32F102xB medium-density USB access line features and peripheral counts

Peripheral		STM32F102Cx		STM32F102Rx	
Flash - Kbytes		64	128	64	128
SRAM - Kbytes		10	16	10	16
Timers	General-purpose	3	3	3	3
Communication interfaces	SPI	2	2	2	2
	I ² C	2	2	2	2
	USART	3	3	3	3
	USB	1	1	1	1
12-bit synchronized ADC number of channels		1 10 channels		1 16 channels	
GPIOs		37		51	
CPU frequency		48 MHz			
Operating voltage		2.0 to 3.6 V			
Operating temperatures		Ambient temperature: -40 to +85 °C (see Table 8) Junction temperature: -40 to +105 °C (see Table 8)			
Packages		LQFP48		LQFP64	

2.2 Full compatibility throughout the family

The STM32F102xx is a complete family whose members are fully pin-to-pin, software and feature compatible. In the reference manual, the STM32F102x4 and STM32F102x6 are referred to as low-density devices and the STM32F102x8 and STM32F102xB are referred to as medium-density devices.

Low-density devices are an extension of the STM32F102x8/B devices, they are specified in the STM32F102x4/6 datasheet. Low-density devices feature lower Flash memory and RAM capacities, a timer and a few communication interfaces less.

The STM32F102x4 and STM32F102x6 are a drop-in replacement for the STM32F102x8/B medium-density devices, allowing the user to try different memory densities and providing a greater degree of freedom during the development cycle.

Moreover the STM32F102xx family is fully compatible with all existing STM32F101xx access line and STM32F103xx performance line devices.

Table 3. STM32F102xx USB access line family

Pinout	Low-density STM32F102xx devices		Medium-density STM32F102xx devices	
	16 KB Flash	32 KB Flash ⁽¹⁾	64 KB Flash	128 KB Flash
	4 KB RAM	6 KB RAM	10 KB RAM	16 KB RAM
64	2 × USARTs, 2 × 16-bit timers		3 × USARTs, 3 × 16-bit timers	
48	1 × SPI, 1 × I ² C, 1 × ADC, 1 × USB		2 × SPIs, 2 × I ² Cs, 1 × ADC, 1 × USB	

1. For orderable part numbers that do not show the A internal code after the temperature range code (6), the reference datasheet for electrical characteristics is that of the STM32F102x8/B medium-density devices.

2.3 Overview

ARM[®] Cortex[™]-M3 core with embedded Flash and SRAM

The ARM Cortex[™]-M3 processor is the latest generation of ARM processors for embedded systems. It has been developed to provide a low-cost platform that meets the needs of MCU implementation, with a reduced pin count and low-power consumption, while delivering outstanding computational performance and an advanced system response to interrupts.

The ARM Cortex[™]-M3 32-bit RISC processor features exceptional code-efficiency, delivering the high-performance expected from an ARM core in the memory size usually associated with 8- and 16-bit devices.

The STM32F102xx medium-density USB access line having an embedded ARM core, is therefore compatible with all ARM tools and software.

Embedded Flash memory

64 or 128 Kbytes of embedded Flash is available for storing programs and data.

CRC (cyclic redundancy check) calculation unit

The CRC (cyclic redundancy check) calculation unit is used to get a CRC code from a 32-bit data word and a fixed generator polynomial.

Among other applications, CRC-based techniques are used to verify data transmission or storage integrity. In the scope of the EN/IEC 60335-1 standard, they offer a means of verifying the Flash memory integrity. The CRC calculation unit helps compute a signature of the software during runtime, to be compared with a reference signature generated at link-time and stored at a given memory location.

Embedded SRAM

10 or 16 Kbytes of embedded SRAM accessed (read/write) at CPU clock speed with 0 wait states.

Nested vectored interrupt controller (NVIC)

The STM32F102xx medium-density USB access line embeds a nested vectored interrupt controller able to handle up to 36 maskable interrupt channels (not including the 16 interrupt lines of Cortex™-M3) and 16 priority levels.

- Closely coupled NVIC gives low latency interrupt processing
- Interrupt entry vector table address passed directly to the core
- Closely coupled NVIC core interface
- Allows early processing of interrupts
- Processing of *late arriving* higher priority interrupts
- Support for tail-chaining
- Processor state automatically saved
- Interrupt entry restored on interrupt exit with no instruction overhead

This hardware block provides flexible interrupt management features with minimal interrupt latency.

External interrupt/event controller (EXTI)

The external interrupt/event controller consists of 19 edge detectors lines used to generate interrupt/event requests. Each line can be independently configured to select the trigger event (rising edge, falling edge, both) and can be masked independently. A pending register maintains the status of the interrupt requests. The EXTI can detect external line with pulse width lower than the Internal APB2 clock period. Up to 51 GPIOs are connected to the 16 external interrupt lines.

Clocks and startup

System clock selection is performed on startup, however the internal RC 8 MHz oscillator is selected as default CPU clock on reset. An external 4-16 MHz clock can be selected, in which case it is monitored for failure. If failure is detected, the system automatically switches back to the internal RC oscillator. A software interrupt is generated if enabled. Similarly, full interrupt management of the PLL clock entry is available when necessary (for example on failure of an indirectly used external crystal, resonator or oscillator).

Several prescalers allow the configuration of the AHB frequency, the High Speed APB (APB2) and the low Speed APB (APB1) domains. The maximum frequency of the AHB and the APB domains is 48 MHz. See [Figure 2](#) for details on the clock tree.

Boot modes

At startup, boot pins are used to select one of five boot options:

- Boot from User Flash
- Boot from System Memory
- Boot from embedded SRAM

The boot loader is located in System Memory. It is used to reprogram the Flash memory by using USART1. For further details please refer to AN2606.

Power supply schemes

- $V_{DD} = 2.0$ to 3.6 V: External power supply for I/Os and the internal regulator. Provided externally through V_{DD} pins.
- V_{SSA} , $V_{DDA} = 2.0$ to 3.6 V: External analog power supplies for ADC, Reset blocks, RCs and PLL (minimum voltage to be applied to V_{DDA} is 2.4 V when the ADC is used). V_{DDA} and V_{SSA} must be connected to V_{DD} and V_{SS} , respectively.
- $V_{BAT} = 1.8$ to 3.6 V: Power supply for RTC, external clock 32 kHz oscillator and backup registers (through power switch) when V_{DD} is not present.

For more details on how to connect power pins, refer to [Figure 8: Power supply scheme](#).

Power supply supervisor

The device has an integrated power on reset (POR)/power down reset (PDR) circuitry. It is always active, and ensures proper operation starting from/down to 2 V. The device remains in reset mode when V_{DD} is below a specified threshold, $V_{POR/PDR}$, without the need for an external reset circuit.

The device features an embedded programmable voltage detector (PVD) that monitors the V_{DD}/V_{DDA} power supply and compares it to the V_{PVD} threshold. An interrupt can be generated when V_{DD}/V_{DDA} drops below the V_{PVD} threshold and/or when V_{DD}/V_{DDA} is higher than the V_{PVD} threshold. The interrupt service routine can then generate a warning message and/or put the MCU into a safe state. The PVD is enabled by software.

Refer to [Table 10: Embedded reset and power control block characteristics](#) for the values of $V_{POR/PDR}$ and V_{PVD} .

Voltage regulator

The regulator has three operation modes: main (MR), low power (LPR) and power down.

- MR is used in the nominal regulation mode (Run)
- LPR is used in the Stop mode
- Power down is used in Standby mode: the regulator output is in high impedance: the kernel circuitry is powered down, inducing zero consumption (but the contents of the registers and SRAM are lost)

This regulator is always enabled after reset. It is disabled in Standby mode, providing high impedance output.

Low-power modes

The STM32F102xx medium-density USB access line supports three low-power modes to achieve the best compromise between low power consumption, short startup time and available wakeup sources:

- **Sleep mode**

In Sleep mode, only the CPU is stopped. All peripherals continue to operate and can wake up the CPU when an interrupt/event occurs.

- **Stop mode**

The Stop mode achieves the lowest power consumption while retaining the content of SRAM and registers. All clocks in the 1.8 V domain are stopped, the PLL, the HSI RC and the HSE crystal oscillators are disabled. The voltage regulator can also be put either in normal or in low power mode.

The device can be woken up from Stop mode by any of the EXTI line. The EXTI line source can be one of the 16 external lines, the PVD output or the RTC alarm.

- **Standby mode**

The Standby mode is used to achieve the lowest power consumption. The internal voltage regulator is switched off so that the entire 1.8 V domain is powered off. The PLL, the HSI RC and the HSE crystal oscillators are also switched off. After entering Standby mode, SRAM and registers content are lost except for registers in the Backup domain and Standby circuitry.

The device exits Standby mode when an external reset (NRST pin), a IWDG reset, a rising edge on the WKUP pin, or an RTC alarm occurs.

Note: The RTC, the IWDG, and the corresponding clock sources are not stopped by entering Stop or Standby mode.

DMA

The flexible 7-channel general-purpose DMA is able to manage memory-to-memory, peripheral-to-memory and memory-to-peripheral transfers. The DMA controller supports circular buffer management avoiding the generation of interrupts when the controller reaches the end of the buffer.

Each channel is connected to dedicated hardware DMA requests, with support for software trigger on each channel. Configuration is made by software and transfer sizes between source and destination are independent.

The DMA can be used with the main peripherals: SPI, I²C, USART, general purpose timers TIMx and ADC.

RTC (real-time clock) and backup registers

The RTC and the backup registers are supplied through a switch that takes power either on V_{DD} supply when present or through the V_{BAT} pin. The backup registers are ten 16-bit registers used to store 20 bytes of user application data when V_{DD} power is not present.

The real-time clock provides a set of continuously running counters which can be used with suitable software to provide a clock calendar function, and provides an alarm interrupt and a periodic interrupt. It is clocked by a 32.768 kHz external crystal, resonator or oscillator, the internal low power RC oscillator or the high-speed external clock divided by 128. The internal low power RC has a typical frequency of 40 kHz. The RTC can be calibrated using an external 512 Hz output to compensate for any natural crystal deviation. The RTC features a 32-bit programmable counter for long term measurement using the Compare

register to generate an alarm. A 20-bit prescaler is used for the time base clock and is by default configured to generate a time base of 1 second from a clock at 32.768 kHz.

Independent watchdog

The independent watchdog is based on a 12-bit downcounter and 8-bit prescaler. It is clocked from an independent 40 kHz internal RC and as it operates independently from the main clock, it can operate in Stop and Standby modes. It can be used as a watchdog to reset the device when a problem occurs, or as a free running timer for application timeout management. It is hardware or software configurable through the option bytes. The counter can be frozen in debug mode.

Window watchdog

The window watchdog is based on a 7-bit downcounter that can be set as free running. It can be used as a watchdog to reset the device when a problem occurs. It is clocked from the main clock. It has an early warning interrupt capability and the counter can be frozen in debug mode.

SysTick timer

This timer is dedicated for OS, but could also be used as a standard down counter. It features:

- A 24-bit down counter
- Autoreload capability
- Maskable system interrupt generation when the counter reaches 0.
- Programmable clock source

General-purpose timers (TIMx)

There are 3 synchronizable general-purpose timers embedded in the STM32F102xx medium-density USB access line devices. These timers are based on a 16-bit auto-reload up/down counter, a 16-bit prescaler and feature 4 independent channels each for input capture, output compare, PWM or one-pulse mode output. This gives up to 12 input captures / output compares / PWMs on the LQFP48 and LQFP64 packages. The general-purpose timers can work together via the Timer Link feature for synchronization or event chaining. Their counter can be frozen in debug mode.

Any of the general-purpose timers can be used to generate PWM outputs. They all have independent DMA request generation.

These timers are capable of handling quadrature (incremental) encoder signals and the digital outputs from 1 to 3 hall-effect sensors.

I²C bus

Two I²C bus interfaces can operate in multi-master and slave modes. They can support standard and fast modes. They support dual slave addressing (7-bit only) and both 7/10-bit addressing in master mode. A hardware CRC generation/verification is embedded.

They can be served by DMA and they support SM Bus 2.0/PM Bus.

Universal synchronous/asynchronous receiver transmitter (USART)

The available USART interfaces communicate at up to 2.25 Mbit/s. They provide hardware management of the CTS and RTS signals, support IrDA SIR ENDEC, are ISO 7816 compliant and have LIN Master/Slave capability.

The USART interfaces can be served by the DMA controller.

Serial peripheral interface (SPI)

Two SPIs are able to communicate up to 12 Mbit/s in slave and master modes in full-duplex and simplex communication modes. The 3-bit prescaler gives 8 master mode frequencies and the frame is configurable to 8 bits or 16 bits. The hardware CRC generation/verification supports basic SD Card/MMC modes.

Both SPIs can be served by the DMA controller.

Universal serial bus (USB)

The STM32F102xx medium-density USB access line embeds a USB device peripheral compatible with the USB Full-speed 12 Mbs. The USB interface implements a full-speed (12 Mbit/s) function interface. It has software configurable endpoint setting and suspend/resume support. The dedicated 48 MHz clock is generated from the internal main PLL (the clock source must use a HSE crystal oscillator).

GPIOs (general-purpose inputs/outputs)

Each of the GPIO pins can be configured by software as output (push-pull or open-drain), as input (with or without pull-up or pull-down) or as peripheral alternate function. Most of the GPIO pins are shared with digital or analog alternate functions. All GPIOs are high current-capable except for analog inputs.

The I/Os alternate function configuration can be locked if needed following a specific sequence in order to avoid spurious writing to the I/Os registers.

ADC (analog to digital converter)

The 12-bit Analog to Digital Converter has up to 16 external channels and performs conversions in single-shot or scan modes. In scan mode, automatic conversion is performed on a selected group of analog inputs.

The ADC can be served by the DMA controller.

An analog watchdog feature allows very precise monitoring of the converted voltage of one, some or all selected channels. An interrupt is generated when the converted voltage is outside the programmed thresholds.

Temperature sensor

The temperature sensor has to generate a voltage that varies linearly with temperature. The conversion range is between $2\text{ V} < V_{\text{DDA}} < 3.6\text{ V}$. The temperature sensor is internally connected to the ADC_IN16 input channel which is used to convert the sensor output voltage into a digital value.

Serial wire JTAG debug port (SWJ-DP)

The ARM SWJ-DP Interface is embedded, and is a combined JTAG and serial wire debug port that enables either a serial wire debug or a JTAG probe to be connected to the target.

The JTAG TMS and TCK pins are shared respectively with SWDIO and SWCLK and a specific sequence on the TMS pin is used to switch between JTAG-DP and SW-DP.

Figure 1. STM32F102xx medium-density USB access line block diagram

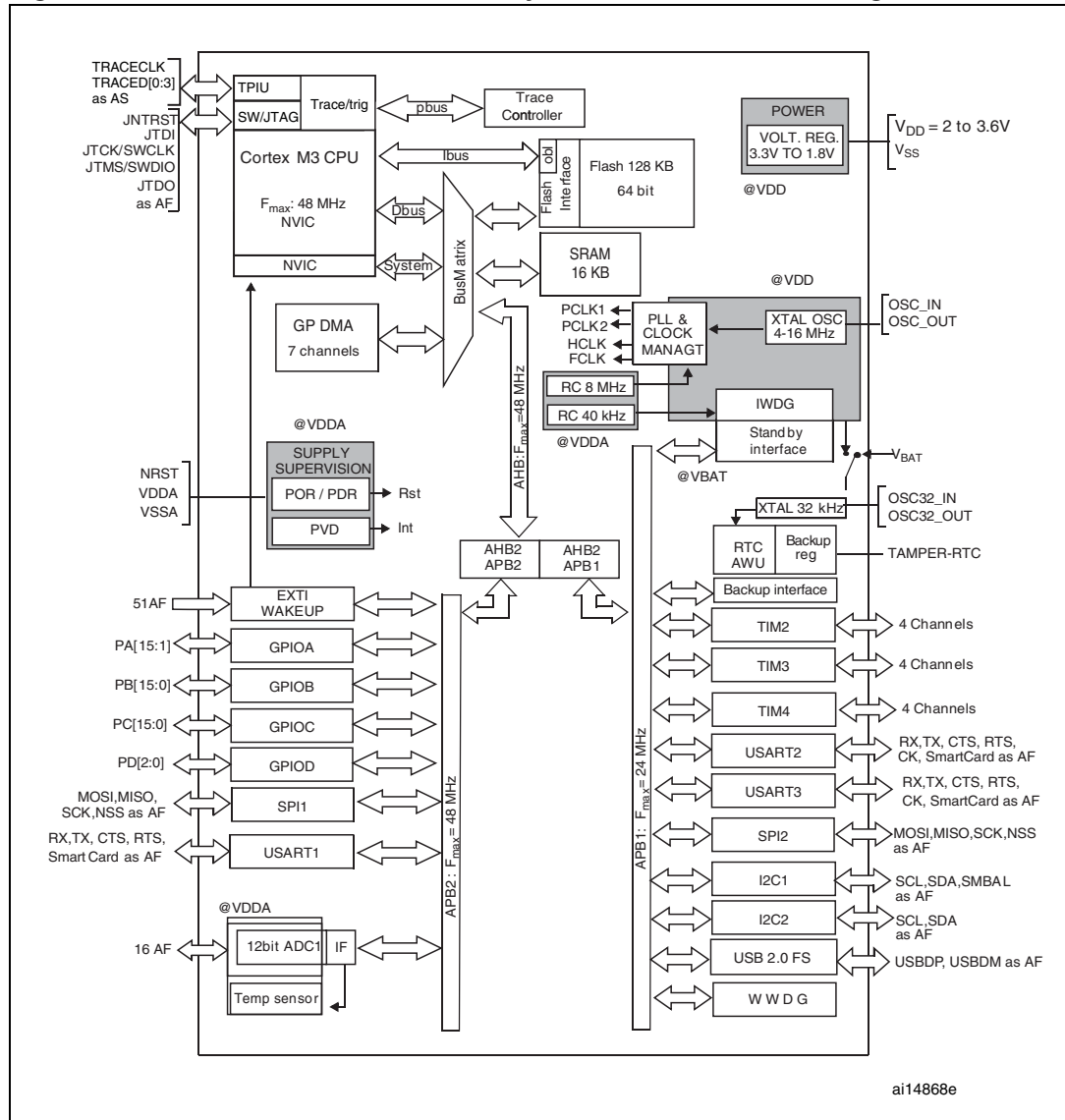

1. AF = alternate function on I/O port pin.
2. $T_A = -40\text{ }^\circ\text{C}$ to $+85\text{ }^\circ\text{C}$ (junction temperature up to $105\text{ }^\circ\text{C}$).

Figure 2. Clock tree

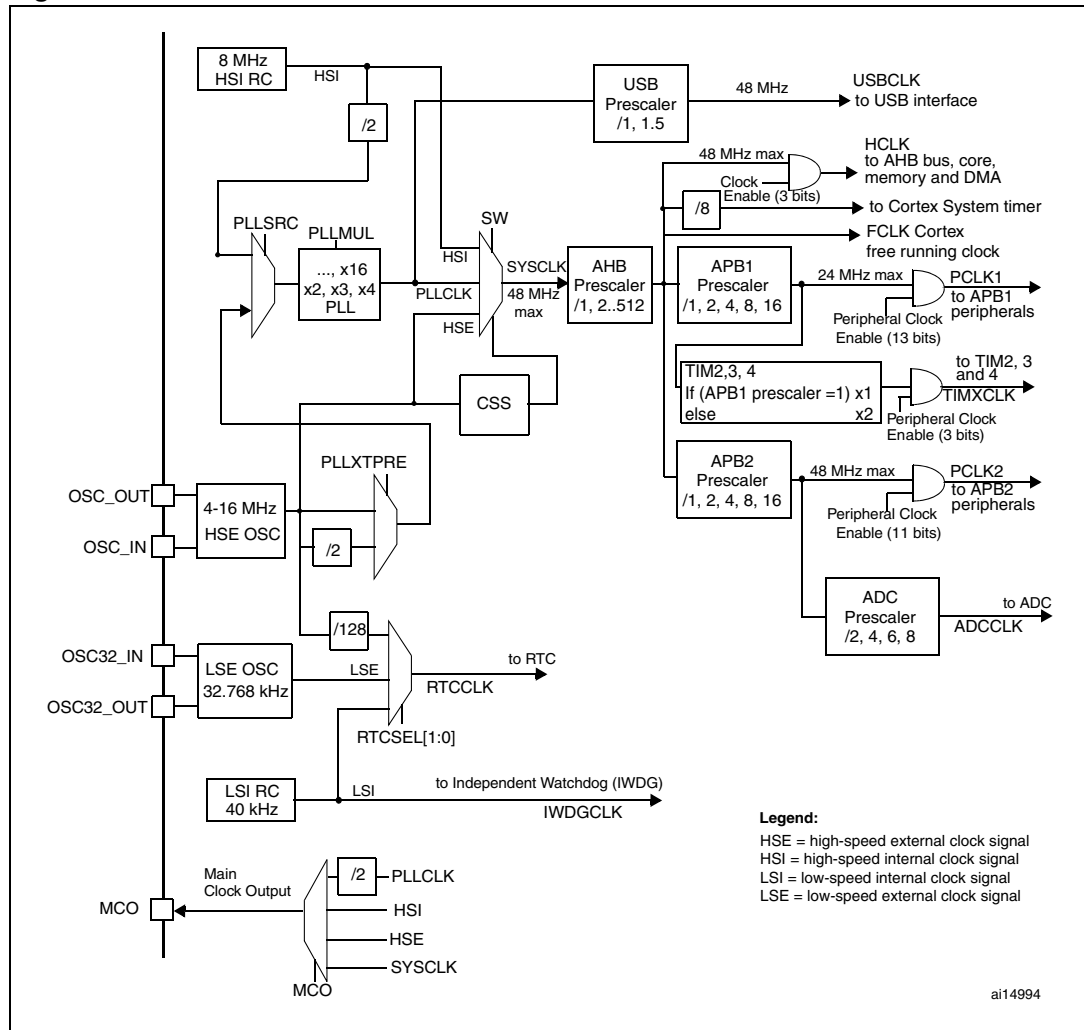

1. For the USB function to be available, both HSE and PLL must be enabled, with the CPU running at 48 MHz.
2. To have an ADC conversion time of 1.2 μs, APB2 must be at 12 MHz, 24 MHz or 48 MHz.

3 Pinouts and pin description

Figure 3. STM32F102xx medium-density USB access line LQFP48 pinout

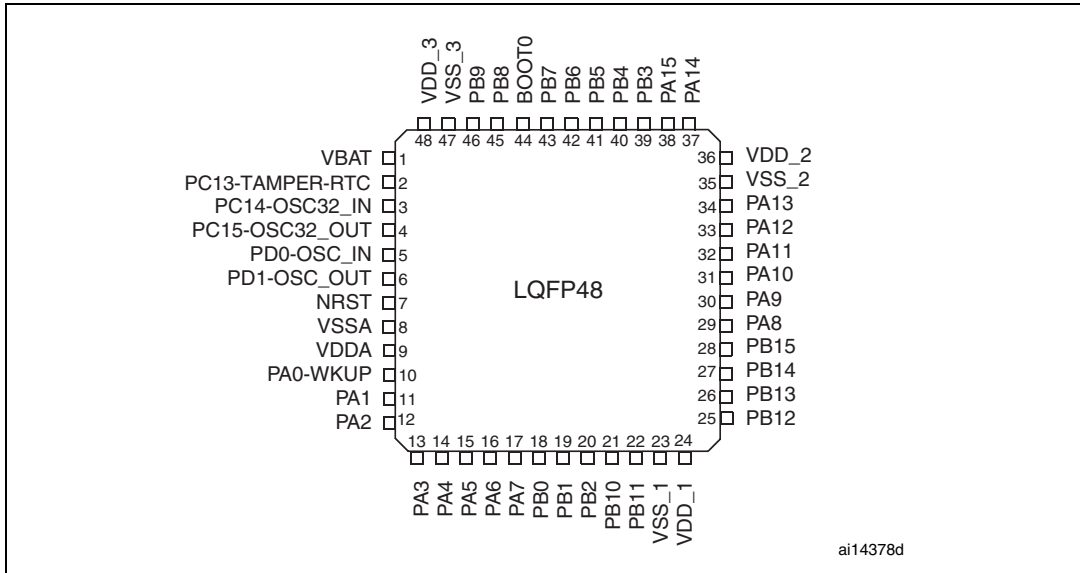

Figure 4. STM32F102xx medium-density USB access line LQFP64 pinout

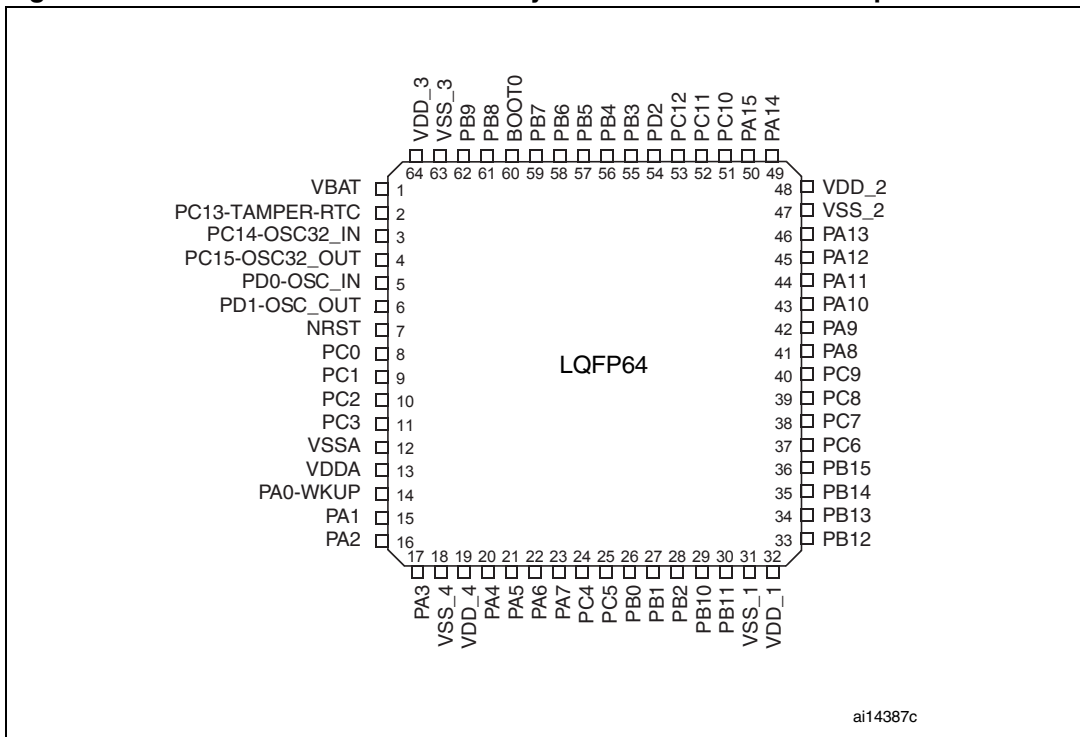

Table 4. Medium-density STM32F102xx pin definitions

Pins		Pin name	Type ⁽¹⁾	I/O level ⁽²⁾	Main function ⁽³⁾ (after reset)	Alternate functions ⁽³⁾	
LQFP48	LQFP64					Default	Remap
1	1	V _{BAT}	S		V _{BAT}		
2	2	PC13-TAMPER-RTC ⁽⁴⁾	I/O		PC13 ⁽⁵⁾	TAMPER-RTC	
3	3	PC14-OSC32_IN ⁽⁴⁾	I/O		PC14 ⁽⁵⁾	OSC32_IN	
4	4	PC15-OSC32_OUT ⁽⁴⁾	I/O		PC15 ⁽⁵⁾	OSC32_OUT	
5	5	PD0	I/O	FT	OSC_IN ⁽⁶⁾		
6	6	PD1	I/O	FT	OSC_OUT ⁽⁶⁾		
7	7	NRST	I/O		NRST		
-	8	PC0	I/O		PC0	ADC_IN10	
-	9	PC1	I/O		PC1	ADC_IN11	
-	10	PC2	I/O		PC2	ADC_IN12	
-	11	PC3	I/O		PC3	ADC_IN13	
8	12	V _{SSA}	S		V _{SSA}		
9	13	V _{DDA}	S		V _{DDA}		
10	14	PA0-WKUP	I/O		PA0	WKUP/USART2_CTS/ ADC_IN0/ TIM2_CH1_ETR ⁽⁷⁾	
11	15	PA1	I/O		PA1	USART2_RTS/ ADC_IN1/TIM2_CH2 ⁽⁷⁾	
12	16	PA2	I/O		PA2	USART2_TX/ ADC_IN2/TIM2_CH3 ⁽⁷⁾	
13	17	PA3	I/O		PA3	USART2_RX/ ADC_IN3/TIM2_CH4 ⁽⁷⁾	
-	18	V _{SS_4}	S		V _{SS_4}		
-	19	V _{DD_4}	S		V _{DD_4}		
14	20	PA4	I/O		PA4	SPI1_NSS ⁽⁷⁾ /ADC_IN4 USART2_CK/	
15	21	PA5	I/O		PA5	SPI1_SCK ⁽⁷⁾ /ADC_IN5	
16	22	PA6	I/O		PA6	SPI1_MISO ⁽⁷⁾ /ADC_IN6/ TIM3_CH1 ⁽⁷⁾	
17	23	PA7	I/O		PA7	SPI1_MOSI ⁽⁷⁾ /ADC_IN7/ TIM3_CH2 ⁽⁷⁾	
-	24	PC4	I/O		PC4	ADC_IN14	
-	25	PC5	I/O		PC5	ADC_IN15	
18	26	PB0	I/O		PB0	ADC_IN8/TIM3_CH3 ⁽⁷⁾	
19	27	PB1	I/O		PB1	ADC_IN9/TIM3_CH4 ⁽⁷⁾	
20	28	PB2	I/O	FT	PB2/BOOT1		

Table 4. Medium-density STM32F102xx pin definitions (continued)

Pins		Pin name	Type ⁽¹⁾	I/O level ⁽²⁾	Main function ⁽³⁾ (after reset)	Alternate functions ⁽³⁾	
LQFP48	LQFP64					Default	Remap
21	29	PB10	I/O	FT	PB10	I2C2_SCL/ USART3_TX ⁽⁷⁾	TIM2_CH3
22	30	PB11	I/O	FT	PB11	I2C2_SDA/ USART3_RX ⁽⁷⁾	TIM2_CH4
23	31	V _{SS_1}	S		V _{SS_1}		
24	32	V _{DD_1}	S		V _{DD_1}		
25	33	PB12	I/O	FT	PB12	SPI2_NSS / I2C2_SMBAL/ USART3_CK ⁽⁷⁾	
26	34	PB13	I/O	FT	PB13	SPI2_SCK ⁽⁷⁾ / USART3_CTS	
27	35	PB14	I/O	FT	PB14	SPI2_MISO/ USART3_RTS	
28	36	PB15	I/O	FT	PB15	SPI2_MOSI	
-	37	PC6	I/O	FT	PC6		TIM3_CH1
-	38	PC7	I/O	FT	PC7		TIM3_CH2
-	39	PC8	I/O	FT	PC8		TIM3_CH3
-	40	PC9	I/O	FT	PC9		TIM3_CH4
29	41	PA8	I/O	FT	PA8	USART1_CK/MCO	
30	42	PA9	I/O	FT	PA9	USART1_TX ⁽⁷⁾	
31	43	PA10	I/O	FT	PA10	USART1_RX ⁽⁷⁾	
32	44	PA11	I/O	FT	PA11	USART1_CTS/USBDM	
33	45	PA12	I/O	FT	PA12	USART1_RTS/USBDP	
34	46	PA13	I/O	FT	JTMS-SWDIO		PA13
35	47	V _{SS_2}	S		V _{SS_2}		
36	48	V _{DD_2}	S		V _{DD_2}		
37	49	PA14	I/O	FT	JTCK/SWCLK		PA14
38	50	PA15	I/O	FT	JTDI		TIM2_CH1_ETR/ PA15/SPI1_NSS
-	51	PC10	I/O	FT	PC10		USART3_TX
-	52	PC11	I/O	FT	PC11		USART3_RX
-	53	PC12	I/O	FT	PC12		USART3_CK
-	54	PD2	I/O	FT	PD2	TIM3_ETR	
39	55	PB3	I/O	FT	JTDO		TIM2_CH2/ PB3/ TRACESWO/ SPI1_SCK
40	56	PB4	I/O	FT	JNTRST		TIM3_CH1 / PB4 SPI1_MISO

Table 4. Medium-density STM32F102xx pin definitions (continued)

Pins		Pin name	Type ⁽¹⁾	I/O level ⁽²⁾	Main function ⁽³⁾ (after reset)	Alternate functions ⁽³⁾	
LQFP48	LQFP64					Default	Remap
41	57	PB5	I/O		PB5	I2C1_SMBAL	TIM3_CH2 / SPI1_MOSI
42	58	PB6	I/O	FT	PB6	I2C1_SCL ⁽⁷⁾ / TIM4_CH1	USART1_TX
43	59	PB7	I/O	FT	PB7	I2C1_SDA ⁽⁷⁾ / TIM4_CH2	USART1_RX
44	60	BOOT0	I		BOOT0		
45	61	PB8	I/O	FT	PB8	TIM4_CH3	I2C1_SCL
46	62	PB9	I/O	FT	PB9	TIM4_CH4	I2C1_SDA
47	63	V _{SS_3}	S		V _{SS_3}		
48	64	V _{DD_3}	S		V _{DD_3}		

1. I = input, O = output, S = supply, HiZ= high impedance.
2. FT= 5 V tolerant.
3. Function availability depends on the chosen device. For devices having reduced peripheral counts, it is always the lower number of peripherals that is included. For example, if a device has only one SPI, two USARTs and two timers, they will be called SPI1, USART1 & USART2 and TIM2 & TIM 3, respectively. Refer to [Table 2 on page 9](#) [Table 3 on page 10](#).
4. PC13, PC14 and PC15 are supplied through the power switch and since the switch only sinks a limited amount of current (3 mA), the use of GPIOs PC13 to PC15 is restricted: only one I/O at a time can be used as an output, the speed has to be limited to 2 MHz with a maximum load of 30 pF and these I/Os must not be used as a current source (e.g. to drive an LED).
5. Main function after the first backup domain power-up. Later on, it depends on the contents of the Backup registers even after reset (because these registers are not reset by the main reset). For details on how to manage these IOs, refer to the Battery backup domain and BKP register description sections in the STM32F102xx reference manual, available from the STMicroelectronics website: www.st.com.
6. The pins number 5 and 6 in the LQFP48 package are configured as OSC_IN/OSC_OUT after reset, however the functionality of PD0 and PD1 can be remapped by software on these pins. For more details, refer to the Alternate function I/O and debug configuration section in the STM32F10xxx reference manual. The use of PD0 and PD1 in output mode is limited as they can only be used at 50 MHz in output mode.
7. This alternate function can be remapped by software to some other port pins (if available on the used package). For more details, refer to the Alternate function I/O and debug configuration section in the STM32F10xxx reference manual, available from the STMicroelectronics website: www.st.com.

4 Memory mapping

The memory map is shown in *Figure 5*.

Figure 5. Memory map

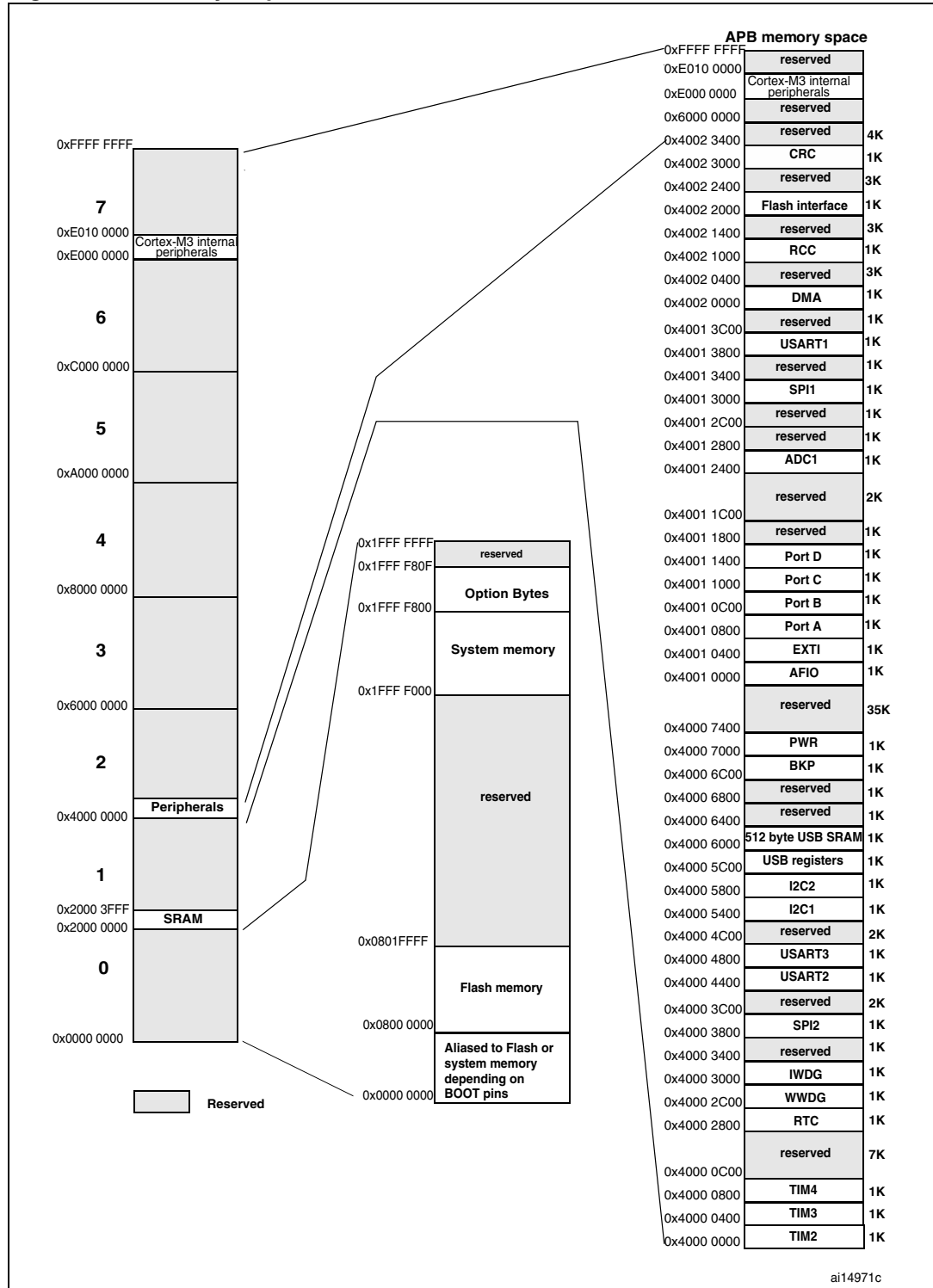

5 Electrical characteristics

5.1 Parameter conditions

Unless otherwise specified, all voltages are referred to V_{SS} .

5.1.1 Minimum and maximum values

Unless otherwise specified the minimum and maximum values are guaranteed in the worst conditions of ambient temperature, supply voltage and frequencies by tests in production on 100% of the devices with an ambient temperature at $T_A = 25\text{ °C}$ and $T_A = T_{A\text{max}}$ (given by the selected temperature range).

Data based on characterization results, design simulation and/or technology characteristics are indicated in the table footnotes and are not tested in production. Based on characterization, the minimum and maximum values refer to sample tests and represent the mean value plus or minus three times the standard deviation ($\text{mean} \pm 3\Sigma$).

5.1.2 Typical values

Unless otherwise specified, typical data are based on $T_A = 25\text{ °C}$, $V_{DD} = 3.3\text{ V}$ (for the $2\text{ V} \leq V_{DD} \leq 3.6\text{ V}$ voltage range). They are given only as design guidelines and are not tested.

Typical ADC accuracy values are determined by characterization of a batch of samples from a standard diffusion lot over the full temperature range, where 95% of the devices have an error less than or equal to the value indicated ($\text{mean} \pm 2\Sigma$).

5.1.3 Typical curves

Unless otherwise specified, all typical curves are given only as design guidelines and are not tested.

5.1.4 Loading capacitor

The loading conditions used for pin parameter measurement are shown in [Figure 6](#).

5.1.5 Pin input voltage

The input voltage measurement on a pin of the device is described in [Figure 7](#).

Figure 6. Pin loading conditions

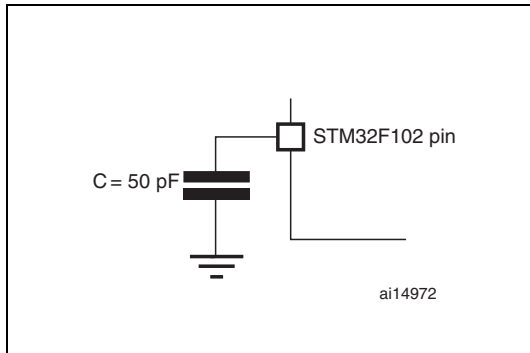
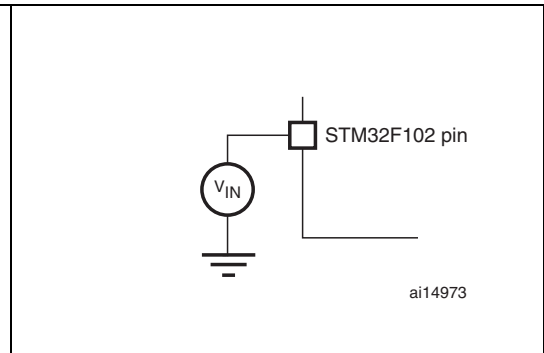
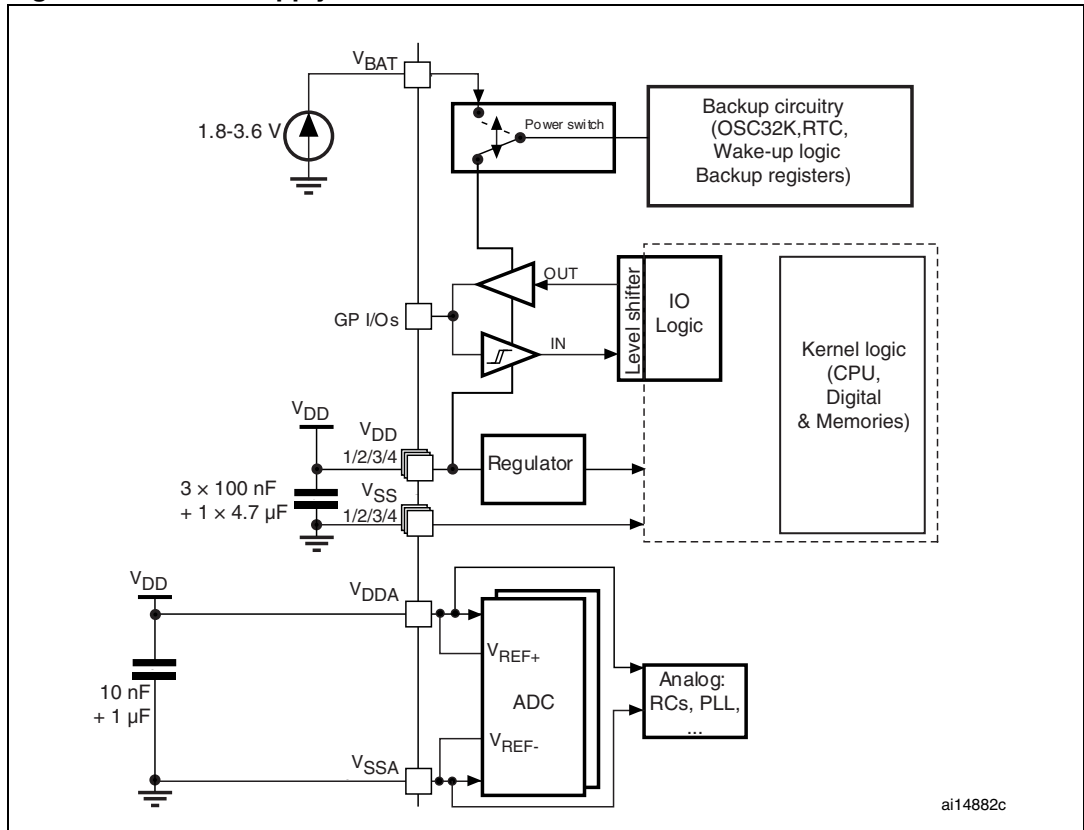

Figure 7. Pin input voltage



5.1.6 Power supply scheme

Figure 8. Power supply scheme



Caution: In [Figure 8](#), the 4.7 μF capacitor must be connected to V_{DD3} .

5.1.7 Current consumption measurement

Figure 9. Current consumption measurement scheme

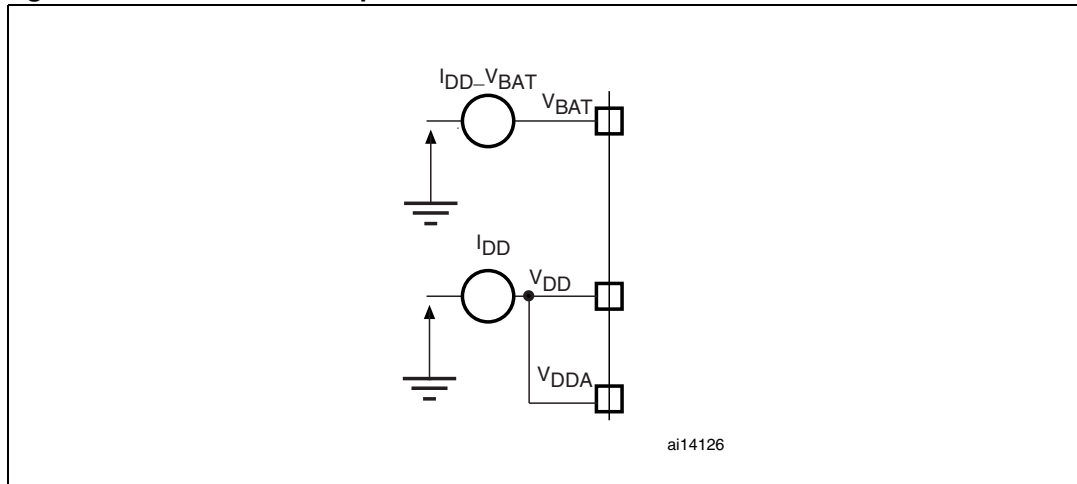

5.2 Absolute maximum ratings

Stresses above the absolute maximum ratings listed in [Table 5: Voltage characteristics](#), [Table 6: Current characteristics](#), and [Table 7: Thermal characteristics](#) may cause permanent damage to the device. These are stress ratings only and functional operation of the device at these conditions is not implied. Exposure to maximum rating conditions for extended periods may affect device reliability.

Table 5. Voltage characteristics

Symbol	Ratings	Min	Max	Unit
$V_{DD} - V_{SS}$	External main supply voltage (including V_{DDA} and V_{DD}) ⁽¹⁾	-0.3	4.0	V
V_{IN}	Input voltage on five volt tolerant pin ⁽²⁾	$V_{SS} - 0.3$	+5.5	
	Input voltage on any other pin ⁽²⁾	$V_{SS} - 0.3$	$V_{DD} + 0.3$	
$ \Delta V_{DDx} $	Variations between different V_{DD} power pins		50	mV
$ V_{SSx} - V_{SS} $	Variations between all the different ground pins		50	
$V_{ESD(HBM)}$	Electrostatic discharge voltage (human body model)	see Section 5.3.11: Absolute maximum ratings (electrical sensitivity)		

1. All main power (V_{DD} , V_{DDA}) and ground (V_{SS} , V_{SSA}) pins must always be connected to the external power supply, in the permitted range.
2. $I_{INJ(PIN)}$ must never be exceeded (see [Table 6: Current characteristics](#)). This is implicitly insured if V_{IN} maximum is respected. If V_{IN} maximum cannot be respected, the injection current must be limited externally to the $I_{INJ(PIN)}$ value. A positive injection is induced by $V_{IN} > V_{INmax}$ while a negative injection is induced by $V_{IN} < V_{SS}$.

Table 6. Current characteristics

Symbol	Ratings	Max.	Unit
I_{VDD}	Total current into V_{DD}/V_{DDA} power lines (source) ⁽¹⁾	150	mA
I_{VSS}	Total current out of V_{SS} ground lines (sink) ⁽¹⁾	150	
I_{IO}	Output current sunk by any I/O and control pin	25	
	Output current source by any I/Os and control pin	- 25	
$I_{INJ(PIN)}$ ⁽²⁾⁽³⁾	Injected current on NRST pin	± 5	
	Injected current on High-speed external OSC_IN and Low-speed external OSC_IN pins	± 5	
	Injected current on any other pin ⁽⁴⁾	± 5	
$\Sigma I_{INJ(PIN)}$ ⁽²⁾	Total injected current (sum of all I/O and control pins) ⁽⁴⁾	± 25	

1. All main power (V_{DD} , V_{DDA}) and ground (V_{SS} , V_{SSA}) pins must always be connected to the external power supply, in the permitted range.
2. $I_{INJ(PIN)}$ must never be exceeded. This is implicitly insured if V_{IN} maximum is respected. If V_{IN} maximum cannot be respected, the injection current must be limited externally to the $I_{INJ(PIN)}$ value. A positive injection is induced by $V_{IN} > V_{DD}$ while a negative injection is induced by $V_{IN} < V_{SS}$.
3. Negative injection disturbs the analog performance of the device. See note in [Section 5.3.16: 12-bit ADC characteristics](#).
4. When several inputs are submitted to a current injection, the maximum $\Sigma I_{INJ(PIN)}$ is the absolute sum of the positive and negative injected currents (instantaneous values). These results are based on characterization with $\Sigma I_{INJ(PIN)}$ maximum current injection on four I/O port pins of the device.

Table 7. Thermal characteristics

Symbol	Ratings	Value	Unit
T_{STG}	Storage temperature range	?-65 to +150	°C
T_J	Maximum junction temperature	150	°C

5.3 Operating conditions

5.3.1 General operating conditions

Table 8. General operating conditions

Symbol	Parameter	Conditions	Min	Max	Unit
f_{HCLK}	Internal AHB clock frequency		0	48	MHz
f_{PCLK1}	Internal APB1 clock frequency		0	24	
f_{PCLK2}	Internal APB2 clock frequency		0	48	
V_{DD}	Standard operating voltage		2	3.6	V
$V_{DDA}^{(1)}$	Analog operating voltage (ADC not used)	Must be the same potential as $V_{DD}^{(2)}$	2	3.6	V
	Analog operating voltage (ADC used)		2.4	3.6	
V_{BAT}	Backup operating voltage		1.8	3.6	V
P_D	Power dissipation at $T_A = 85\text{ °C}^{(3)}$	LQFP48		363	mW
		LQFP64		444	
T_A	Ambient temperature	Maximum power dissipation	-40	85	°C
		Low power dissipation ⁽⁴⁾	-40	105	°C
T_J	Junction temperature range		-40	105	°C

1. When the ADC is used, refer to [Table 44: ADC characteristics](#).
2. It is recommended to power V_{DD} and V_{DDA} from the same source. A maximum difference of 300 mV between V_{DD} and V_{DDA} can be tolerated during power-up and operation.
3. If T_A is lower, higher P_D values are allowed as long as T_J does not exceed T_{Jmax} (see [Table 6.2: Thermal characteristics on page 65](#)).
4. In low power dissipation state, T_A can be extended to this range as long as T_J does not exceed T_{Jmax} (see [Table 6.2: Thermal characteristics on page 65](#)).

5.3.2 Operating conditions at power-up / power-down

Subject to general operating conditions for T_A .

Table 9. Operating conditions at power-up / power-down

Symbol	Parameter	Conditions	Min	Max	Unit
t_{VDD}	V_{DD} rise time rate		0	∞	$\mu\text{s/V}$
	V_{DD} fall time rate		20	∞	

5.3.3 Embedded reset and power control block characteristics

The parameters given in [Table 10](#) are derived from tests performed under ambient temperature and V_{DD} supply voltage conditions summarized in [Table 8](#).

Table 10. Embedded reset and power control block characteristics

Symbol	Parameter	Conditions	Min	Typ	Max	Unit
V_{PVD}	Programmable voltage detector level selection	PLS[2:0]=000 (rising edge)	2.1	2.18	2.26	V
		PLS[2:0]=000 (falling edge)	2	2.08	2.16	V
		PLS[2:0]=001 (rising edge)	2.19	2.28	2.37	V
		PLS[2:0]=001 (falling edge)	2.09	2.18	2.27	V
		PLS[2:0]=010 (rising edge)	2.28	2.38	2.48	V
		PLS[2:0]=010 (falling edge)	2.18	2.28	2.38	V
		PLS[2:0]=011 (rising edge)	2.38	2.48	2.58	V
		PLS[2:0]=011 (falling edge)	2.28	2.38	2.48	V
		PLS[2:0]=100 (rising edge)	2.47	2.58	2.69	V
		PLS[2:0]=100 (falling edge)	2.37	2.48	2.59	V
		PLS[2:0]=101 (rising edge)	2.57	2.68	2.79	V
		PLS[2:0]=101 (falling edge)	2.47	2.58	2.69	V
		PLS[2:0]=110 (rising edge)	2.66	2.78	2.9	V
		PLS[2:0]=110 (falling edge)	2.56	2.68	2.8	V
		PLS[2:0]=111 (rising edge)	2.76	2.88	3	V
PLS[2:0]=111 (falling edge)	2.66	2.78	2.9	V		
$V_{PVDhyst}^{(2)}$	PVD hysteresis			100		mV
$V_{POR/PDR}$	Power on/power down reset threshold	Falling edge	1.8 ⁽¹⁾	1.88	1.96	V
		Rising edge	1.84	1.92	2.0	V
$V_{PDRhyst}$	PDR hysteresis			40		mV
$t_{RSTEMPO}^{(2)}$	Reset temporization		1.5	2.5	4.5	ms

1. The product behavior is guaranteed by design down to the minimum $V_{POR/PDR}$ value.

2. Guaranteed by design, not tested in production.

5.3.4 Embedded reference voltage

The parameters given in [Table 11](#) are derived from tests performed under ambient temperature and V_{DD} supply voltage conditions summarized in [Table 8](#).

Table 11. Embedded internal reference voltage

Symbol	Parameter	Conditions	Min	Typ	Max	Unit
V_{REFINT}	Internal reference voltage	$-40\text{ }^{\circ}\text{C} < T_A < +85\text{ }^{\circ}\text{C}$	1.16	1.20	1.24	V
$T_{S_vrefint}^{(1)}$	ADC sampling time when reading the internal reference voltage			5.1	17.1 ⁽²⁾	μs

1. Shortest sampling time can be determined in the application by multiple iterations.
2. Guaranteed by design, not tested in production.

5.3.5 Supply current characteristics

The current consumption is a function of several parameters and factors such as the operating voltage, ambient temperature, I/O pin loading, device software configuration, operating frequencies, I/O pin switching rate, program location in memory and executed binary code.

The current consumption is measured as described in [Figure 9: Current consumption measurement scheme](#).

All Run-mode current consumption measurements given in this section are performed with a reduced code that gives a consumption equivalent to Dhrystone 2.1 code.

Maximum current consumption

The MCU is placed under the following conditions:

- All I/O pins are in input mode with a static value at V_{DD} or V_{SS} (no load)
- All peripherals are disabled except if it is explicitly mentioned
- The Flash access time is adjusted to f_{HCLK} frequency (0 wait state from 0 to 24 MHz, 1 wait state from 24 to 48 MHz)
- Prefetch in on (reminder: this bit must be set before clock setting and bus prescaling)
- When the peripherals are enabled $f_{PCLK1} = f_{HCLK}/2$, $f_{PCLK2} = f_{HCLK}$

The parameters given in [Table 12](#) are derived from tests performed under ambient temperature and V_{DD} supply voltage conditions summarized in [Table 8](#).

Table 12. Maximum current consumption in Run mode, code with data processing running from Flash

Symbol	Parameter	Conditions	f _{HCLK}	Max ⁽¹⁾	Unit
				T _A = 85 °C	
I _{DD}	Supply current in Run mode	External clock ⁽²⁾ , all peripherals enabled	48 MHz	36.1	mA
			36 MHz	28.6	
			24 MHz	19.9	
			16 MHz	14.7	
			8 MHz	8.6	
		External clock ⁽²⁾ , all peripherals Disabled	48 MHz	24.4	
			36 MHz	19.8	
			24 MHz	13.9	
			16 MHz	10.7	
			8 MHz	6.8	

1. Based on characterization results, not tested in production.
2. External clock is 8 MHz and PLL is on when f_{HCLK} > 8 MHz.

Table 13. Maximum current consumption in Run mode, code with data processing running from RAM

Symbol	Parameter	Conditions	f _{HCLK}	Max	Unit
				T _A = 85 °C ⁽¹⁾	
I _{DD}	Supply current in Run mode	External clock ⁽²⁾ , all peripherals enabled	48 MHz	31.5	mA
			36 MHz	24	
			24 MHz	17.5	
			16 MHz	12.5	
			8 MHz	7.5	
		External clock ⁽²⁾ all peripherals disabled	48 MHz	20.5	
			36 MHz	16	
			24 MHz	11.5	
			16 MHz	8.5	
			8 MHz	5.5	

1. Based on characterization, tested in production at V_{DD} max, f_{HCLK} max.
2. External clock is 8 MHz and PLL is on when f_{HCLK} > 8 MHz.

Figure 10. Typical current consumption in Run mode versus temperature (at 3.6 V) - code with data processing running from RAM, peripherals enabled

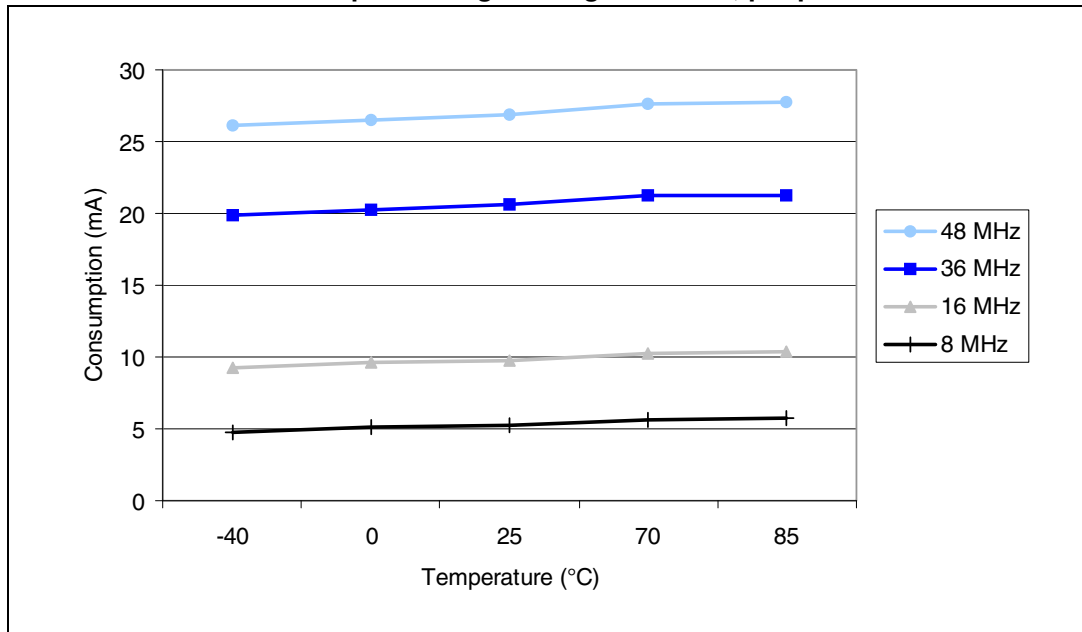

Figure 11. Typical current consumption in Run mode versus temperature (at 3.6 V) - code with data processing running from RAM, peripherals disabled

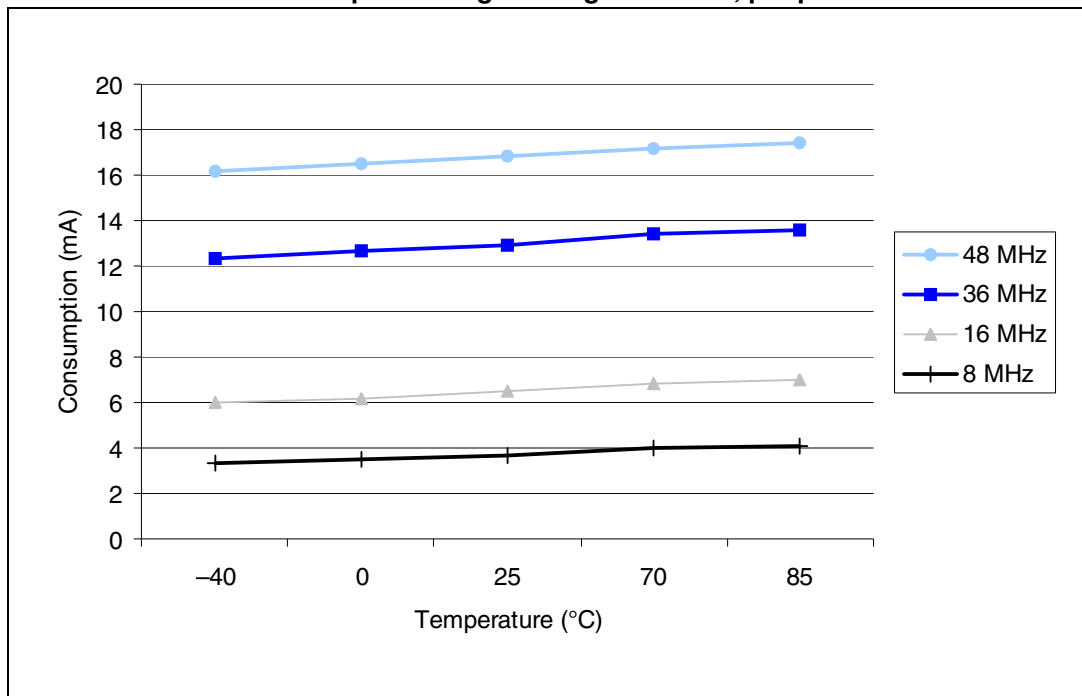

Table 14. Maximum current consumption in Sleep mode, code running from Flash or RAM

Symbol	Parameter	Conditions	f _{HCLK}	Max ⁽¹⁾	Unit
				T _A = 85 °C	
I _{DD}	Supply current in Sleep mode	External clock ⁽²⁾ all peripherals enabled	48 MHz	20	mA
			36 MHz	15.5	
			24 MHz	11.5	
			16 MHz	8.5	
			8 MHz	5.5	
		External clock ⁽²⁾ , all peripherals disabled	48 MHz	6	
			36 MHz	5	
			24 MHz	4.5	
			16 MHz	4	
			8 MHz	3	

1. Based on characterization, tested in production at V_{DD} max and f_{HCLK} max with peripherals enabled.
2. External clock is 8 MHz and PLL is on when f_{HCLK} > 8 MHz.

Table 15. Typical and maximum current consumptions in Stop and Standby modes

Symbol	Parameter	Conditions	Typ ⁽¹⁾		Max	Unit
			V _{DD} /V _{BAT} = 2.4 V	V _{DD} /V _{BAT} = 3.3 V	T _A = 85 °C	
I _{DD}	Supply current in Stop mode	Regulator in Run mode, Low-speed and high-speed internal RC oscillators and high-speed oscillator OFF (no independent watchdog)	23.5	24	200	µA
		Regulator in Low Power mode, Low-speed and high-speed internal RC oscillators and high-speed oscillator OFF (no independent watchdog)	13.5	14	180	
	Supply current in Standby mode ⁽²⁾	Low-speed internal RC oscillator and independent watchdog ON	2.6	3.4	TBD ⁽³⁾	
		Low-speed internal RC oscillator ON, independent watchdog OFF	2.4	3.2	TBD ⁽³⁾	
		Low-speed internal RC oscillator and independent watchdog OFF, low-speed oscillator and RTC OFF	1.7	2	4	
	I _{DD_VBAT}	Backup domain supply current	Low-speed oscillator and RTC ON	1.1	1.4	

1. Typical values are measured at T_A = 25 °C.
2. To have the Standby consumption with RTC ON, add I_{DD_VBAT} (Low-speed oscillator and RTC ON) to I_{DD} Standby (when V_{DD} is present the Backup Domain is powered by V_{DD} supply).
3. TBD stands for to be determined.
4. Based on characterization, not tested in production.

Figure 12. Typical current consumption in Stop mode with regulator in Run mode versus temperature at $V_{DD} = 3.3\text{ V}$ and 3.6 V

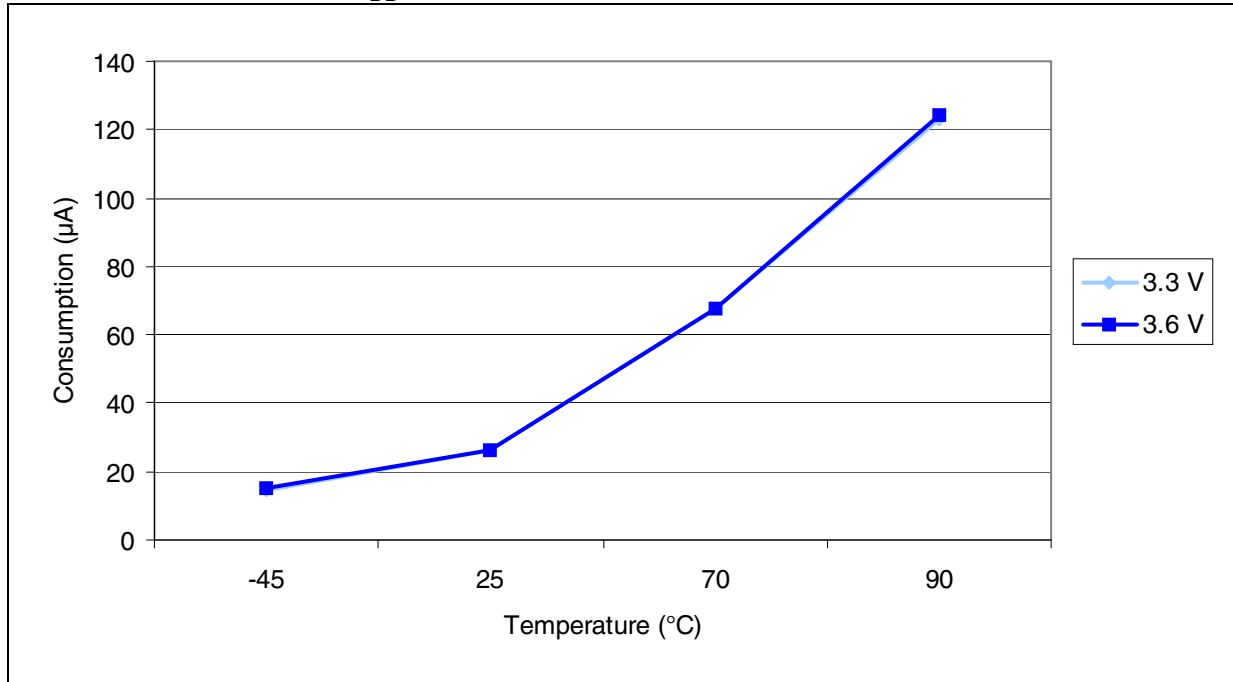

Figure 13. Typical current consumption in Stop mode with regulator in Low-power mode versus temperature at $V_{DD} = 3.3\text{ V}$ and 3.6 V

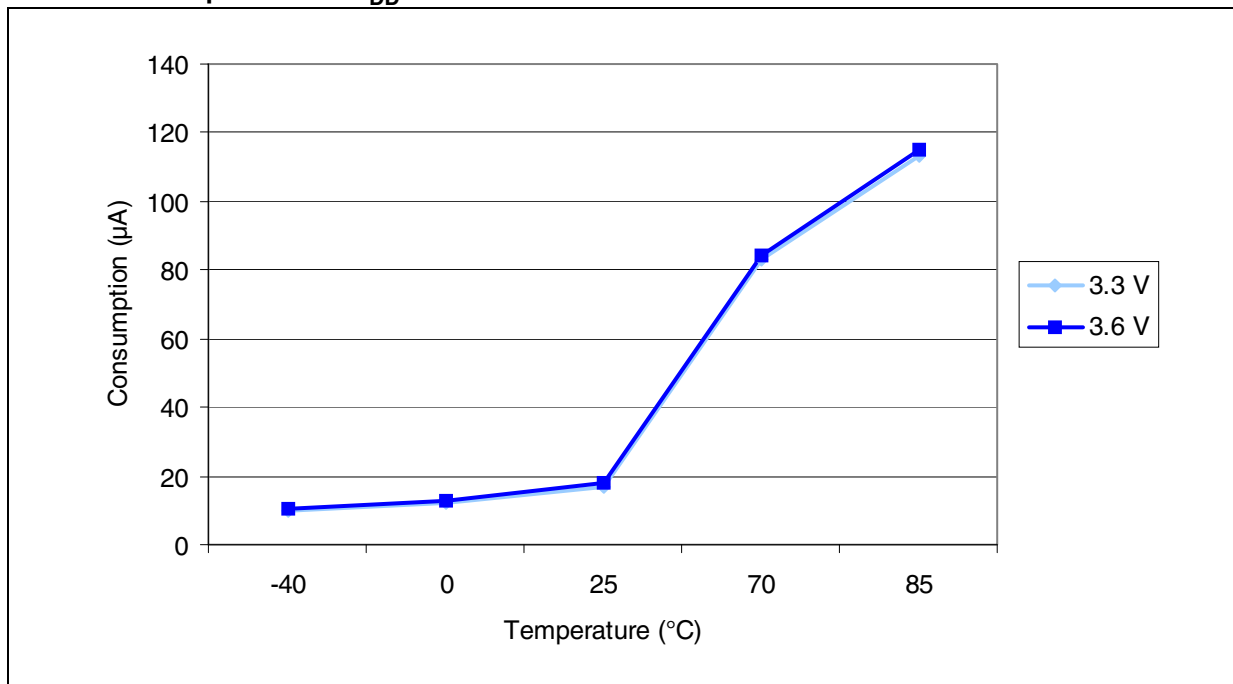
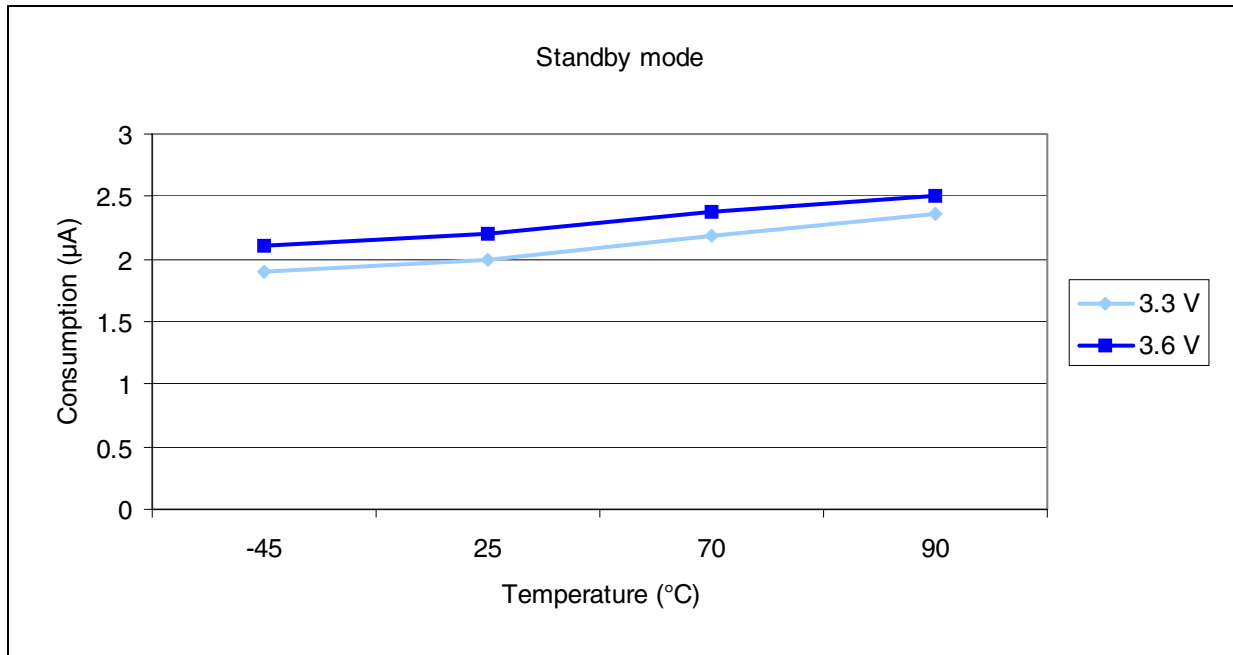

Figure 14. Typical current consumption in Standby mode versus temperature at $V_{DD} = 3.3\text{ V}$ and 3.6 V



Typical current consumption

The MCU is placed under the following conditions:

- All I/O pins are in input mode with a static value at V_{DD} or V_{SS} (no load)
- All peripherals are disabled except if it is explicitly mentioned
- The Flash access time is adjusted to f_{HCLK} frequency (0 wait state from 0 to 24 MHz, 1 wait state from 24 to 48 MHz)
- Prefetch is on (reminder: this bit must be set before clock setting and bus prescaling)
- When the peripherals are enabled f_{PCLK1} = f_{HCLK}/4, f_{PCLK2} = f_{HCLK}/2, f_{ADCCLK} = f_{PCLK2}/4

The parameters given in [Table 16](#) are derived from tests performed under ambient temperature and V_{DD} supply voltage conditions summarized in [Table 8](#).

Table 16. Typical current consumption in Run mode, code with data processing running from Flash

Symbol	Parameter	Conditions	f _{HCLK}	Typ ⁽¹⁾		Unit
				All peripherals enabled ⁽²⁾	All peripherals disabled	
I _{DD}	Supply current in Run mode	External clock ⁽³⁾	48 MHz	24.2	18.6	mA
			36 MHz	19	14.8	
			24 MHz	12.9	10.1	
			16 MHz	9.3	7.4	
			8 MHz	5.5	4.6	
			4 MHz	3.3	2.8	
			2 MHz	2.2	1.9	
			1 MHz	1.6	1.45	
			500 kHz	1.3	1.25	
			125 kHz	1.08	1.06	
		Running on high speed internal RC (HSI), AHB prescaler used to reduce the frequency	48 MHz	23.5	17.9	
			36 MHz	18.3	14.1	
			24 MHz	12.2	9.5	
			16 MHz	8.5	6.8	
			8 MHz	4.9	4	
			4 MHz	2.7	2.2	
			2 MHz	1.6	1.4	
			1 MHz	1.02	0.9	
			500 kHz	0.73	0.67	
			125 kHz	0.5	0.48	

1. Typical values are measures at T_A = 25 °C, V_{DD} = 3.3 V.
2. Add an additional power consumption of 0.8 mA per ADC for the analog part. In applications, this consumption occurs only while the ADC is on (ADON bit is set in the ADC_CR2 register).
3. External clock is 8 MHz and PLL is on when f_{HCLK} > 8 MHz.

Table 17. Typical current consumption in Sleep mode, code running from Flash or RAM

Symbol	Parameter	Conditions	f _{HCLK}	Typ ⁽¹⁾		Unit
				All peripherals enabled ⁽²⁾	All peripherals disabled	
IDD	Supply current in Sleep mode	External clock ⁽³⁾	48 MHz	9.9	3.9	mA
			36 MHz	7.6	3.1	
			24 MHz	5.3	2.3	
			16 MHz	3.8	1.8	
			8 MHz	2.1	1.2	
			4 MHz	1.6	1.1	
			2 MHz	1.3	1	
			1 MHz	1.11	0.98	
			500 kHz	1.04	0.96	
			125 kHz	0.98	0.95	
		Running on High Speed Internal RC (HSI), AHB prescaler used to reduce the frequency	48 MHz	9.3	3.3	
			36 MHz	7	2.5	
			24 MHz	4.8	1.8	
			16 MHz	3.2	1.2	
			8 MHz	1.6	0.6	
			4 MHz	1	0.5	
			2 MHz	0.72	0.47	
			1 MHz	0.56	0.44	
			500 kHz	0.49	0.42	
			125 kHz	0.43	0.41	

1. Typical values are measures at T_A = 25 °C, V_{DD} = 3.3 V.
2. Add an additional power consumption of 0.8 mA per ADC for the analog part. In applications, this consumption occurs only while the ADC is on (ADON bit is set in the ADC_CR2 register).
3. External clock is 8 MHz and PLL is on when f_{HCLK} > 8 MHz.

On-chip peripheral current consumption

The current consumption of the on-chip peripherals is given in [Table 18](#). The MCU is placed under the following conditions:

- all I/O pins are in input mode with a static value at V_{DD} or V_{SS} (no load)
- all peripherals are disabled unless otherwise mentioned
- the given value is calculated by measuring the current consumption
 - with all peripherals clocked off
 - with only one peripheral clocked on
- ambient operating temperature and V_{DD} supply voltage conditions summarized in [Table 5](#).

Table 18. Peripheral current consumption

Peripheral		Typical consumption at 25 °C ⁽¹⁾	Unit
APB1	TIM2	0.90	mA
	TIM3	0.86	
	TIM4	0.88	
	SPI2	0.26	
	USART2	0.45	
	USART3	0.43	
	USB	0.57	
	I2C1	0.24	
	I2C2	0.25	
APB2	GPIO A	0.45	
	GPIO B	0.32	
	GPIO C	0.49	
	GPIO D	0.32	
	ADC1 ⁽²⁾	1.51	
	SPI1	0.21	
	USART1	0.72	

1. f_{HCLK} = 48 MHz, f_{APB1} = f_{HCLK}/2, f_{APB2} = f_{HCLK}, default prescaler value for each peripheral.
 2. Specific conditions for ADC: f_{HCLK} = 48 MHz, f_{APB1} = f_{HCLK}/2, f_{APB2} = f_{HCLK}, f_{ADCCLK} = f_{HCLK}/4, ADON bit in the ADC_CR2 register is set to 1.

5.3.6 External clock source characteristics

High-speed external user clock generated from an external source

The characteristics given in [Table 19](#) result from tests performed using an high-speed external clock source, and under ambient temperature and supply voltage conditions summarized in [Table 8](#).

Table 19. High-speed external user clock characteristics

Symbol	Parameter	Conditions	Min	Typ	Max	Unit
f_{HSE_ext}	User external clock source frequency ⁽¹⁾		0	8	25	MHz
V_{HSEH}	OSC_IN input pin high level voltage		$0.7V_{DD}$		V_{DD}	V
V_{HSEL}	OSC_IN input pin low level voltage		V_{SS}		$0.3V_{DD}$	
$t_{w(HSE)}$ $t_{w(HSE)}$	OSC_IN high or low time ⁽¹⁾		16			ns
$t_{r(HSE)}$ $t_{f(HSE)}$	OSC_IN rise or fall time ⁽¹⁾				20	
$C_{in(HSE)}$	OSC_IN input capacitance ⁽¹⁾			5		pF
$DuCy_{(HSE)}$	Duty cycle		45		55	%
I_L	OSC_IN Input leakage current	$V_{SS} \leq V_{IN} \leq V_{DD}$			± 1	μA

1. Guaranteed by design, not tested in production.

Low-speed external user clock generated from an external source

The characteristics given in [Table 20](#) result from tests performed using an low-speed external clock source, and under ambient temperature and supply voltage conditions summarized in [Table 8](#).

Table 20. Low-speed external user clock characteristics

Symbol	Parameter	Conditions	Min	Typ	Max	Unit
f_{LSE_ext}	User external clock source frequency ⁽¹⁾			32.768	1000	kHz
V_{LSEH}	OSC32_IN input pin high level voltage		$0.7V_{DD}$		V_{DD}	V
V_{LSEL}	OSC32_IN input pin low level voltage		V_{SS}		$0.3V_{DD}$	
$t_{w(LSE)}$ $t_{w(LSE)}$	OSC32_IN high or low time ⁽¹⁾		450			ns
$t_{r(LSE)}$ $t_{f(LSE)}$	OSC32_IN rise or fall time ⁽¹⁾				50	
$C_{in(LSE)}$	OSC32_IN input capacitance ⁽¹⁾			5		pF
$DuCy_{(LSE)}$	Duty cycle		30		70	%
I_L	OSC32_IN Input leakage current	$V_{SS} \leq V_{IN} \leq V_{DD}$			± 1	μA

1. Guaranteed by design, not tested in production.

Figure 15. High-speed external clock source AC timing diagram

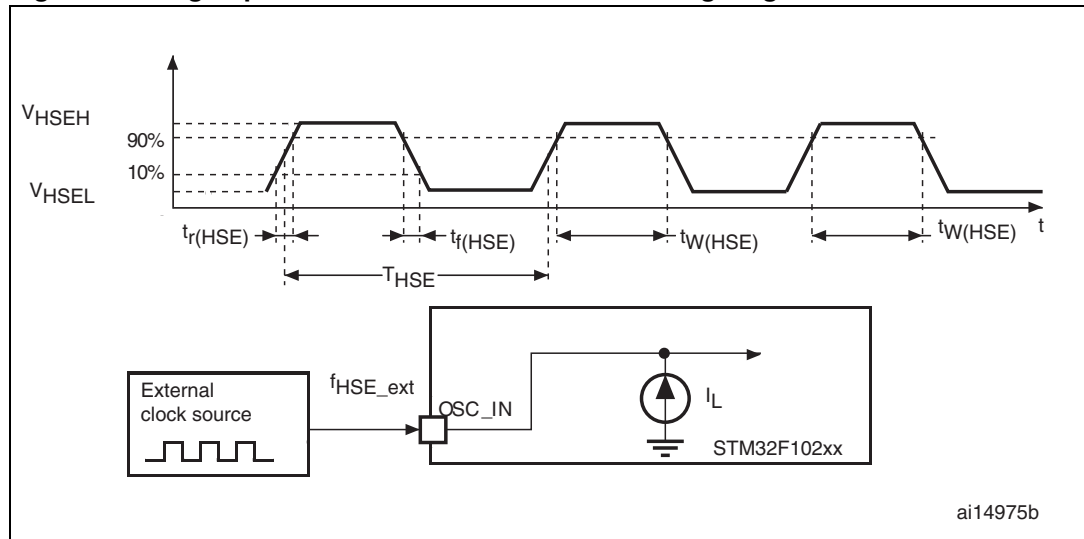
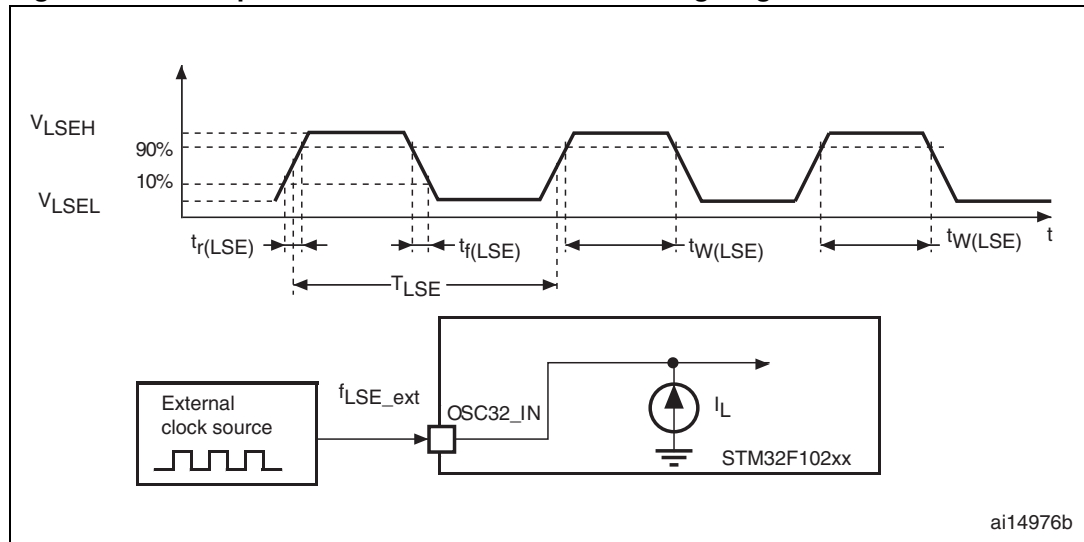

Figure 16. Low-speed external clock source AC timing diagram



High-speed external clock generated from a crystal/ceramic resonator

The high-speed external (HSE) clock can be supplied with a 4 to 16 MHz crystal/ceramic resonator oscillator. All the information given in this paragraph are based on characterization results obtained with typical external components specified in [Table 21](#). In the application, the resonator and the load capacitors have to be placed as close as possible to the oscillator pins in order to minimize output distortion and startup stabilization time. Refer to the crystal resonator manufacturer for more details on the resonator characteristics (frequency, package, accuracy).

Table 21. HSE 4-16 MHz oscillator characteristics⁽¹⁾⁽²⁾

Symbol	Parameter	Conditions	Min	Typ	Max	Unit
f_{OSC_IN}	Oscillator frequency		4	8	16	MHz
R_F	Feedback resistor			200		k Ω
C_{L1} $C_{L2}^{(3)}$	Recommended load capacitance versus equivalent serial resistance of the crystal (R_S) ⁽⁴⁾	$R_S = 30 \Omega$		30		pF
i_2	HSE driving current	$V_{DD} = 3.3 V$ $V_{IN} = V_{SS}$ with 30 pF load			1	mA
g_m	Oscillator transconductance	Startup	25			mA/V
$t_{SU(HSE)}^{(5)}$	Startup time	V_{DD} is stabilized		2		ms

1. Resonator characteristics given by the crystal/ceramic resonator manufacturer.
2. Based on characterization results, not tested in production.
3. For C_{L1} and C_{L2} it is recommended to use high-quality ceramic capacitors in the 5 pF to 25 pF range (typ.), designed for high-frequency applications, and selected to match the requirements of the crystal or resonator. C_{L1} and C_{L2} are usually the same size. The crystal manufacturer typically specifies a load capacitance which is the series combination of C_{L1} and C_{L2} . PCB and MCU pin capacitance must be included (10 pF can be used as a rough estimate of the combined pin and board capacitance) when sizing C_{L1} and C_{L2} .
4. The relatively low value of the R_F resistor offers a good protection against issues resulting from use in a humid environment, due to the induced leakage and the bias condition change. However, it is recommended to take this point into account if the MCU is used in tough humidity conditions.
5. $t_{SU(HSE)}$ is the startup time measured from the moment it is enabled (by software) to a stabilized 8 MHz oscillation is reached. This value is measured for a standard crystal resonator and it can vary significantly with the crystal manufacturer

Figure 17. Typical application with an 8 MHz crystal

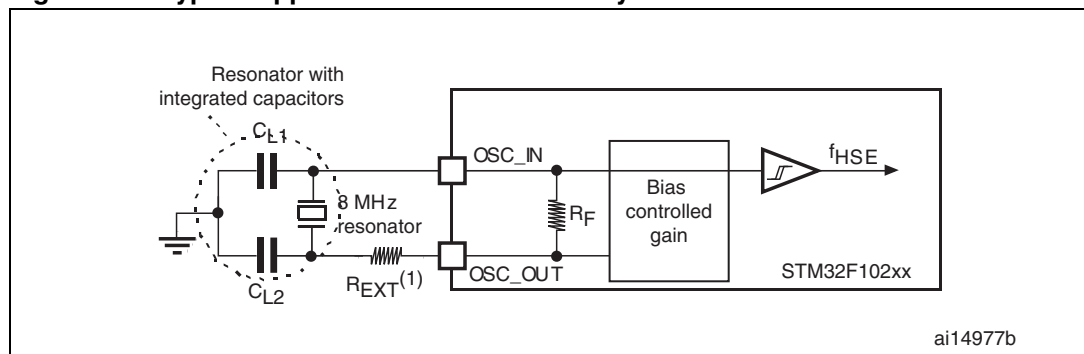

1. R_{EXT} value depends on the crystal characteristics. Typical value is in the range of 5 to 6 R_S .

Low-speed external clock generated from a crystal/ceramic resonator

The low-speed external (LSE) clock can be supplied with a 32.768 kHz crystal/ceramic resonator oscillator. All the information given in this paragraph are based on characterization results obtained with typical external components specified in [Table 22](#). In the application, the resonator and the load capacitors have to be placed as close as possible to the oscillator pins in order to minimize output distortion and startup stabilization time. Refer to the crystal resonator manufacturer for more details on the resonator characteristics (frequency, package, accuracy).

Note: For C_{L1} and C_{L2} it is recommended to use high-quality ceramic capacitors in the 5 pF to 15 pF range selected to match the requirements of the crystal or resonator. C_{L1} and C_{L2} are usually the same size. The crystal manufacturer typically specifies a load capacitance which is the series combination of C_{L1} and C_{L2} .

Load capacitance C_L has the following formula: $C_L = C_{L1} \times C_{L2} / (C_{L1} + C_{L2}) + C_{stray}$ where C_{stray} is the pin capacitance and board or trace PCB-related capacitance. Typically, it is between 2 pF and 7 pF.

Caution: To avoid exceeding the maximum value of C_{L1} and C_{L2} (15 pF) it is strongly recommended to use a resonator with a load capacitance $C_L \leq 7$ pF. Never use a resonator with a load capacitance of 12.5 pF.

Example: if you choose a resonator with a load capacitance of $C_L = 6$ pF, and $C_{stray} = 2$ pF, then $C_{L1} = C_{L2} = 8$ pF.

Table 22. LSE oscillator characteristics ($f_{LSE} = 32.768$ kHz)

Symbol	Parameter	Conditions	Min	Typ	Max	Unit
R_F	Feedback resistor			5		$M\Omega$
C_{L1} $C_{L2}^{(1)}$	Recommended load capacitance versus equivalent serial resistance of the crystal (R_S) ⁽²⁾	$R_S = 30 K\Omega$			15	pF
I_2	LSE driving current	$V_{DD} = 3.3 V$ $V_{IN} = V_{SS}$			1.4	μA
g_m	Oscillator transconductance		5			$\mu A/V$
$t_{SU(LSE)}^{(3)}$	Startup time	V_{DD} is stabilized		3		s

1. Refer to the note and caution paragraphs above the table.
2. The oscillator selection can be optimized in terms of supply current using an high quality resonator with small R_S value for example MSIV-TIN32.768 kHz. Refer to crystal manufacturer for more details
3. $t_{SU(LSE)}$ is the startup time measured from the moment it is enabled (by software) to a stabilized 32.768 kHz oscillation is reached. This value is measured for a standard crystal resonator and it can vary significantly with the crystal manufacturer

Figure 18. Typical application with a 32.768 kHz crystal

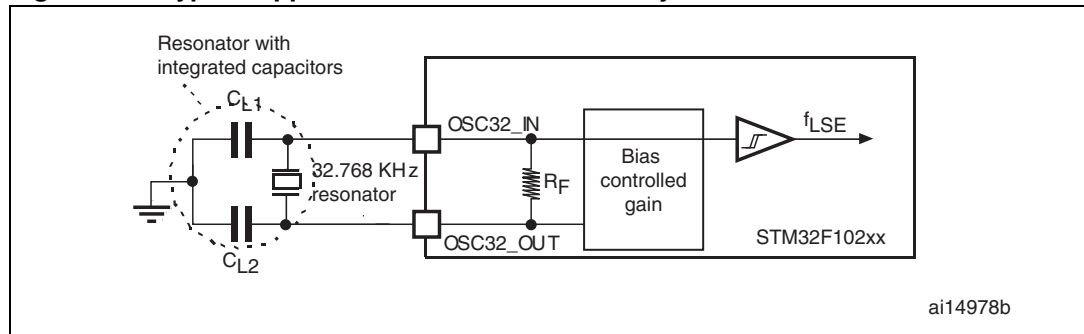

5.3.7 Internal clock source characteristics

The parameters given in [Table 23](#) are derived from tests performed under ambient temperature and V_{DD} supply voltage conditions summarized in [Table 8](#).

High-speed internal (HSI) RC oscillator

Table 23. HSI oscillator characteristics⁽¹⁾⁽²⁾

Symbol	Parameter	Conditions	Min	Typ	Max	Unit
f_{HSI}	Frequency			8		MHz
ACC_{HSI}	Accuracy of HSI oscillator	$T_A = -40$ to 85 °C	-2	± 1	2.5	%
		$T_A = -10$ to 85 °C	-1.5	± 1	2.2	%
		$T_A = 0$ to 70 °C	-1.3	± 1	2	%
		$T_A = 25$ °C	-1.1	± 1	1.8	%
$t_{su(HSI)}$	HSI oscillator startup time		1		2	μs
$I_{DD(HSI)}$	HSI oscillator power consumption			80	100	μA

1. Guaranteed by design, not tested in production.
2. $V_{DD} = 3.3$ V, $T_A = -40$ to 85 °C unless otherwise specified.

Low-speed internal (LSI) RC oscillator

Table 24. LSI oscillator characteristics⁽¹⁾

Symbol	Parameter	Min ⁽²⁾	Typ	Max	Unit
f_{LSI}	Frequency	30	40	60	kHz
$t_{su(LSI)}^{(3)}$	LSI oscillator startup time			85	μs
$I_{DD(LSI)}^{(3)}$	LSI oscillator power consumption		0.65	1.2	μA

1. $V_{DD} = 3$ V, $T_A = -40$ to 85 °C unless otherwise specified.
2. Based on characterization, not tested in production.
3. Guaranteed by design, not tested in production.

Wakeup time from low-power mode

The wakeup times given in [Table 25](#) is measured on a wakeup phase with a 8-MHz HSI RC oscillator. The clock source used to wake up the device depends from the current operating mode:

- Stop or Standby mode: the clock source is the RC oscillator
- Sleep mode: the clock source is the clock that was set before entering Sleep mode.

All timings are derived from tests performed under ambient temperature and V_{DD} supply voltage conditions summarized in [Table 8](#).

Table 25. Low-power mode wakeup timings

Symbol	Parameter	Conditions	Typ	Unit
$t_{WUSLEEP}^{(1)}$	Wakeup from Sleep mode	Wakeup on HSI RC clock	1.8	μs
$t_{WUSTOP}^{(1)}$	Wakeup from Stop mode (regulator in run mode)	HSI RC wakeup time = 2 μs	3.6	μs
	Wakeup from Stop mode (regulator in low-power mode)	HSI RC wakeup time = 2 μs , Regulator wakeup from LP mode time = 5 μs	5.4	
$t_{WUSTDBY}^{(1)}$	Wakeup from Standby mode	HSI RC wakeup time = 2 μs , Regulator wakeup from power down time = 38 μs	50	μs

1. The wakeup times are measured from the wakeup event to the point at which the user application code reads the first instruction.

5.3.8 PLL characteristics

The parameters given in [Table 26](#) are derived from tests performed under ambient temperature and V_{DD} supply voltage conditions summarized in [Table 8](#).

Table 26. PLL characteristics

Symbol	Parameter	Value			Unit
		Min ⁽¹⁾	Typ	Max ⁽¹⁾	
f_{PLL_IN}	PLL input clock ⁽²⁾	1	8.0	25	MHz
	PLL input clock duty cycle	40		60	%
f_{PLL_OUT}	PLL multiplier output clock	16		48	MHz
t_{LOCK}	PLL lock time			200	μs

1. Based on characterization, not tested in production.
2. Take care of using the appropriate multiplier factors so as to have PLL input clock values compatible with the range defined by f_{PLL_OUT} .

5.3.9 Memory characteristics

Flash memory

The characteristics are given at $T_A = -40$ to 85 °C unless otherwise specified.

Table 27. Flash memory characteristics

Symbol	Parameter	Conditions	Min ⁽¹⁾	Typ	Max ⁽¹⁾	Unit
t_{prog}	16-bit programming time	$T_A = -40$ to $+85$ °C	40	52.5	70	µs
t_{ERASE}	Page (1 KB) erase time	$T_A = -40$ to $+85$ °C	20		40	ms
t_{ME}	Mass erase time	$T_A = -40$ to $+85$ °C	20		40	ms
I_{DD}	Supply current	Read mode $f_{HCLK} = 48$ MHz with 2 wait states, $V_{DD} = 3.3$ V			20	mA
		Write / Erase modes $f_{HCLK} = 48$ MHz, $V_{DD} = 3.3$ V			5	mA
		Power-down mode / Halt, $V_{DD} = 3.0$ to 3.6 V			50	µA
V_{prog}	Programming voltage		2		3.6	V

1. Guaranteed by design, not tested in production.

Table 28. Flash memory endurance and data retention

Symbol	Parameter	Conditions	Value			Unit
			Min ⁽¹⁾	Typ	Max	
N_{END}	Endurance		10			kcycles
t_{RET}	Data retention	$T_A = 85$ °C, 1000 cycles	30			Years

1. Based on characterization not tested in production.

5.3.10 EMC characteristics

Susceptibility tests are performed on a sample basis during device characterization.

Functional EMS (Electromagnetic susceptibility)

While a simple application is executed on the device (toggling 2 LEDs through I/O ports), the device is stressed by two electromagnetic events until a failure occurs. The failure is indicated by the LEDs:

- **Electrostatic discharge (ESD)** (positive and negative) is applied to all device pins until a functional disturbance occurs. This test is compliant with the IEC 1000-4-2 standard.
- **FTB:** A Burst of Fast Transient voltage (positive and negative) is applied to V_{DD} and V_{SS} through a 100 pF capacitor, until a functional disturbance occurs. This test is compliant with the IEC 1000-4-4 standard.

A device reset allows normal operations to be resumed.

The test results are given in [Table 29](#). They are based on the EMS levels and classes defined in application note AN1709.

Table 29. EMS characteristics

Symbol	Parameter	Conditions	Level/Class
V _{FESD}	Voltage limits to be applied on any I/O pin to induce a functional disturbance	V _{DD} = 3.3 V, T _A = +25 °C, f _{HCLK} = 48 MHz conforms to IEC 1000-4-2	2B
V _{EFTB}	Fast transient voltage burst limits to be applied through 100 pF on V _{DD} and V _{SS} pins to induce a functional disturbance	V _{DD} = 3.3 V, T _A = +25 °C, f _{HCLK} = 48 MHz conforms to IEC 1000-4-4	4A

Designing hardened software to avoid noise problems

EMC characterization and optimization are performed at component level with a typical application environment and simplified MCU software. It should be noted that good EMC performance is highly dependent on the user application and the software in particular.

Therefore it is recommended that the user applies EMC software optimization and pre qualification tests in relation with the EMC level requested for his application.

Software recommendations

The software flowchart must include the management of runaway conditions such as:

- Corrupted program counter
- Unexpected reset
- Critical Data corruption (control registers...)

Prequalification trials

Most of the common failures (unexpected reset and program counter corruption) can be reproduced by manually forcing a low state on the NRST pin or the Oscillator pins for 1 second. To complete these trials, ESD stress can be applied directly on the device, over the range of specification values. When unexpected behavior is detected, the software can be hardened to prevent unrecoverable errors occurring (see application note AN1015).

Electromagnetic Interference (EMI)

The electromagnetic field emitted by the device is monitored while a simple application is executed (toggling 2 LEDs through the I/O ports). This emission test is compliant with SAE J 1752/3 standard which specifies the test board and the pin loading.

Table 30. EMI characteristics

Symbol	Parameter	Conditions	Monitored frequency band	Max vs. [f _{HSE} /f _{HCLK}]	Unit
				8/48 MHz	
S _{EMI}	Peak level	V _{DD} = 3.3 V, T _A = 25 °C,	0.1 MHz to 30 MHz	7	dBμV
			30 MHz to 130 MHz	8	
			130 MHz to 1GHz	13	
			SAE EMI Level	3.5	-

5.3.11 Absolute maximum ratings (electrical sensitivity)

Based on three different tests (ESD, LU) using specific measurement methods, the device is stressed in order to determine its performance in terms of electrical sensitivity.

Electrostatic discharge (ESD)

Electrostatic discharges (a positive then a negative pulse separated by 1 second) are applied to the pins of each sample according to each pin combination. The sample size depends on the number of supply pins in the device (3 parts × (n+1) supply pins). This test conforms to the JESD22-A114/C101 standard.

Table 31. ESD absolute maximum ratings

Symbol	Ratings	Conditions	Class	Maximum value ⁽¹⁾	Unit
V _{ESD(HBM)}	Electrostatic discharge voltage (human body model)	T _A = +25 °C conforming to JESD22-A114	2	2000	V
V _{ESD(CDM)}	Electrostatic discharge voltage (charge device model)	T _A = +25 °C conforming to JESD22-C101	II	500	

1. Based on characterization results, not tested in production.

Static latch-up

Two complementary static tests are required on six parts to assess the latch-up performance:

- A supply overvoltage is applied to each power supply pin
- A current injection is applied to each input, output and configurable I/O pin

These tests are compliant with EIA/JESD 78 IC latch-up standard.

Table 32. Electrical sensitivities

Symbol	Parameter	Conditions	Class
LU	Static latch-up class	T _A = +105 °C conforming to JESD78A	II level A

5.3.12 I/O port characteristics

General input/output characteristics

Unless otherwise specified, the parameters given in [Table 33](#) are derived from tests performed under the conditions summarized in [Table 8](#). All I/Os are CMOS and TTL compliant.

Table 33. I/O static characteristics

Symbol	Parameter	Conditions	Min	Typ	Max	Unit
V_{IL}	Input low level voltage	TTL ports	-0.5		0.8	V
V_{IH}	Standard IO input high level voltage		2		$V_{DD}+0.5$	
	IO FT ⁽¹⁾ input high level voltage		2		5.5V	
V_{IL}	Input low level voltage	CMOS ports	-0.5		$0.35 V_{DD}$	V
V_{IH}	Input high level voltage		$0.65 V_{DD}$		$V_{DD}+0.5$	
V_{hys}	Standard IO Schmitt trigger voltage hysteresis ⁽²⁾		200			mV
	IO FT Schmitt trigger voltage hysteresis ⁽²⁾		$5\% V_{DD}$ ⁽³⁾			mV
I_{lkg}	Input leakage current ⁽³⁾	$V_{SS} \leq V_{IN} \leq V_{DD}$ Standard I/Os			± 1	μA
		$V_{IN} = 5 V$ I/O FT			3	
R_{PU}	Weak pull-up equivalent resistor ⁽⁴⁾	$V_{IN} = V_{SS}$	30	40	50	k Ω
R_{PD}	Weak pull-down equivalent resistor ⁽⁵⁾	$V_{IN} = V_{DD}$	30	40	50	k Ω
C_{IO}	I/O pin capacitance			5		pF

1. FT = Five-volt tolerant.
2. Hysteresis voltage between Schmitt trigger switching levels. Based on characterization results, not tested in production.
3. With a minimum of 100 mV.
4. Leakage could be higher than max. if negative current is injected on adjacent pins.
5. Pull-up and pull-down resistors are designed with a true resistance in series with a switchable PMOS/NMOS. This PMOS/NMOS contribution to the series resistance is minimum (~10% order).

All I/Os are CMOS and TTL compliant (no software configuration required), their characteristics consider the most strict CMOS-technology or TTL parameters:

- For V_{IH} :
 - if V_{DD} is in the [2.00 V - 3.08 V] range: CMOS characteristics but TTL included
 - if V_{DD} is in the [3.08 V - 3.60 V] range: TTL characteristics but CMOS included
- For V_{IL} :
 - if V_{DD} is in the [2.00 V - 2.28 V] range: TTL characteristics but CMOS included
 - if V_{DD} is in the [2.28 V - 3.60 V] range: CMOS characteristics but TTL included

Output driving current

The GPIOs (general purpose input/outputs) can sink or source up to +/-8 mA, and sink +20 mA (with a relaxed V_{OL}).

In the user application, the number of I/O pins which can drive current must be limited to respect the absolute maximum rating specified in [Section 5.2](#):

- The sum of the currents sourced by all the I/Os on V_{DD} , plus the maximum Run consumption of the MCU sourced on V_{DD} , cannot exceed the absolute maximum rating I_{VDD} (see [Table 6](#)).
- The sum of the currents sunk by all the I/Os on V_{SS} plus the maximum Run consumption of the MCU sunk on V_{SS} cannot exceed the absolute maximum rating I_{VSS} (see [Table 6](#)).

Output voltage levels

Unless otherwise specified, the parameters given in [Table 34](#) are derived from tests performed under ambient temperature and V_{DD} supply voltage conditions summarized in [Table 8](#). All I/Os are CMOS and TTL compliant.

Table 34. Output voltage characteristics

Symbol	Parameter	Conditions	Min	Max	Unit
$V_{OL}^{(1)}$	Output Low level voltage for an I/O pin when 8 pins are sunk at the same time	TTL port, $I_{IO} = +8 \text{ mA}$, $2.7 \text{ V} < V_{DD} < 3.6 \text{ V}$		0.4	V
$V_{OH}^{(2)}$	Output High level voltage for an I/O pin when 8 pins are sourced at the same time		$V_{DD}-0.4$		
$V_{OL}^{(1)}$	Output low level voltage for an I/O pin when 8 pins are sunk at the same time	CMOS port $I_{IO} = +8 \text{ mA}$ $2.7 \text{ V} < V_{DD} < 3.6 \text{ V}$		0.4	V
$V_{OH}^{(2)}$	Output high level voltage for an I/O pin when 8 pins are sourced at the same time		2.4		
$V_{OL}^{(1)}$	Output low level voltage for an I/O pin when 8 pins are sunk at the same time	$I_{IO} = +20 \text{ mA}^{(3)}$ $2.7 \text{ V} < V_{DD} < 3.6 \text{ V}$		1.3	V
$V_{OH}^{(2)}$	Output high level voltage for an I/O pin when 8 pins are sourced at the same time		$V_{DD}-1.3$		
$V_{OL}^{(1)}$	Output low level voltage for an I/O pin when 8 pins are sunk at the same time	$I_{IO} = +6 \text{ mA}^{(3)}$ $2 \text{ V} < V_{DD} < 2.7 \text{ V}$		0.4	V
$V_{OH}^{(2)}$	Output high level voltage for an I/O pin when 8 pins are sourced at the same time		$V_{DD}-0.4$		

1. The I_{IO} current sunk by the device must always respect the absolute maximum rating specified in [Table 6](#) and the sum of I_{IO} (I/O ports and control pins) must not exceed I_{VSS} .
2. The I_{IO} current sourced by the device must always respect the absolute maximum rating specified in [Table 6](#) and the sum of I_{IO} (I/O ports and control pins) must not exceed I_{VDD} .
3. Based on characterization data, not tested in production.

Input/output AC characteristics

The definition and values of input/output AC characteristics are given in [Figure 19](#) and [Table 35](#), respectively.

Unless otherwise specified, the parameters given in [Table 35](#) are derived from tests performed under ambient temperature and V_{DD} supply voltage conditions summarized in [Table 8](#).

Table 35. I/O AC characteristics⁽¹⁾

MODEx [1:0] bit value ⁽¹⁾	Symbol	Parameter	Conditions	Max	Unit	
10	$f_{\max(I/O)out}$	Maximum frequency ⁽²⁾	$C_L = 50 \text{ pF}, V_{DD} = 2 \text{ V to } 3.6 \text{ V}$	2	MHz	
	$t_{f(I/O)out}$	Output high to low level fall time	$C_L = 50 \text{ pF}, V_{DD} = 2 \text{ V to } 3.6 \text{ V}$	125 ⁽³⁾	ns	
	$t_{r(I/O)out}$	Output low to high level rise time		125 ⁽³⁾		
01	$f_{\max(I/O)out}$	Maximum frequency ⁽²⁾	$C_L = 50 \text{ pF}, V_{DD} = 2 \text{ V to } 3.6 \text{ V}$	10	MHz	
	$t_{f(I/O)out}$	Output high to low level fall time	$C_L = 50 \text{ pF}, V_{DD} = 2 \text{ V to } 3.6 \text{ V}$	25 ⁽³⁾	ns	
	$t_{r(I/O)out}$	Output low to high level rise time		25 ⁽³⁾		
11	$F_{\max(I/O)out}$	Maximum Frequency ⁽²⁾	$C_L = 30 \text{ pF}, V_{DD} = 2.7 \text{ V to } 3.6 \text{ V}$	50	MHz	
			$C_L = 50 \text{ pF}, V_{DD} = 2.7 \text{ V to } 3.6 \text{ V}$	30		MHz
			$C_L = 50 \text{ pF}, V_{DD} = 2 \text{ V to } 2.7 \text{ V}$	20		
	$t_{f(I/O)out}$	Output high to low level fall time	$C_L = 30 \text{ pF}, V_{DD} = 2.7 \text{ V to } 3.6 \text{ V}$	5 ⁽³⁾	ns	
			$C_L = 50 \text{ pF}, V_{DD} = 2.7 \text{ V to } 3.6 \text{ V}$	8 ⁽³⁾		
			$C_L = 50 \text{ pF}, V_{DD} = 2 \text{ V to } 2.7 \text{ V}$	12 ⁽³⁾		
$t_{r(I/O)out}$	Output low to high level rise time	$C_L = 30 \text{ pF}, V_{DD} = 2.7 \text{ V to } 3.6 \text{ V}$	5 ⁽³⁾			
		$C_L = 50 \text{ pF}, V_{DD} = 2.7 \text{ V to } 3.6 \text{ V}$	8 ⁽³⁾			
		$C_L = 50 \text{ pF}, V_{DD} = 2 \text{ V to } 2.7 \text{ V}$	12 ⁽³⁾			
-	t_{EXTIpw}	Pulse width of external signals detected by the EXTI controller		10	ns	

1. The I/O speed is configured using the MODEx[1:0] bits. Refer to the STM32F10xxx reference manual for a description of GPIO Port configuration register.
2. The maximum frequency is defined in [Figure 19](#).
3. Guaranteed by design, not tested in production.

Figure 19. I/O AC characteristics definition

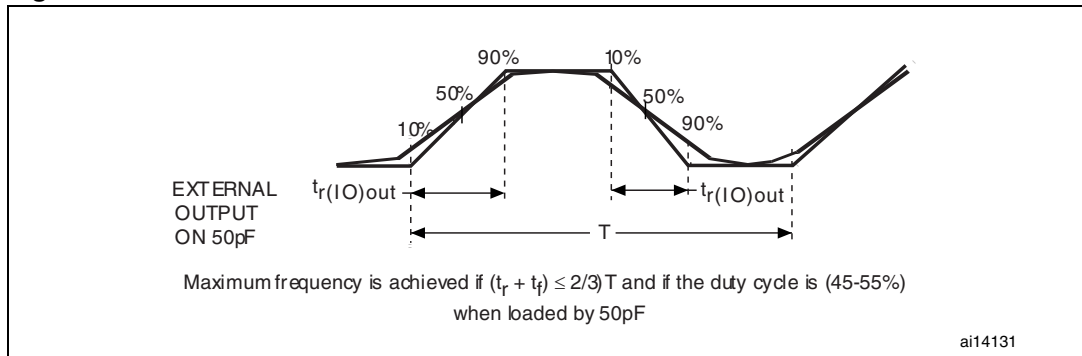

5.3.13 NRST pin characteristics

The NRST pin input driver uses CMOS technology. It is connected to a permanent pull-up resistor, R_{PU} (see [Table 33](#)).

Unless otherwise specified, the parameters given in [Table 36](#) are derived from tests performed under ambient temperature and V_{DD} supply voltage conditions summarized in [Table 8](#).

Table 36. NRST pin characteristics

Symbol	Parameter	Conditions	Min	Typ	Max	Unit
$V_{IL(NRST)}^{(1)}$	NRST Input low level voltage		-0.5		0.8	V
$V_{IH(NRST)}^{(1)}$	NRST Input high level voltage		2		$V_{DD}+0.5$	
$V_{hys(NRST)}$	NRST Schmitt trigger voltage hysteresis			200		mV
R_{PU}	Weak pull-up equivalent resistor ⁽²⁾	$V_{IN} = V_{SS}$	30	40	50	k Ω
$V_{F(NRST)}^{(1)}$	NRST Input filtered pulse				100	ns
$V_{NF(NRST)}^{(1)}$	NRST Input not filtered pulse		300			ns

1. Guaranteed by design, not tested in production.
2. The pull-up is designed with a true resistance in series with a switchable PMOS. This PMOS contribution to the series resistance must be minimum (~10% order).

Figure 20. Recommended NRST pin protection

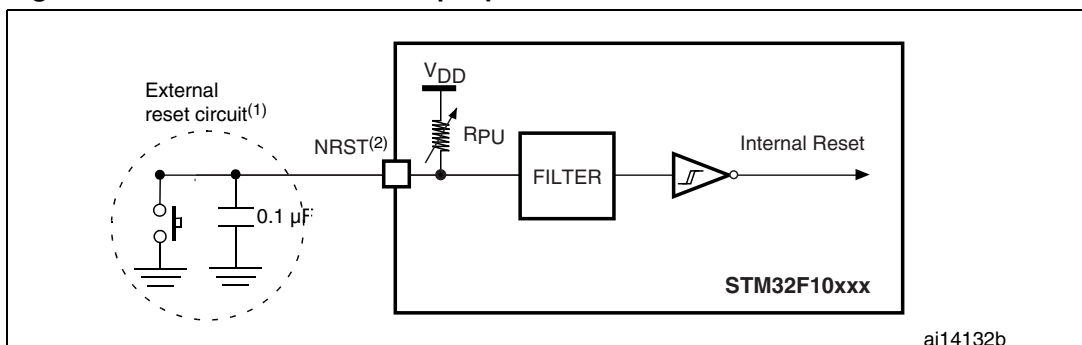

1. The reset network protects the device against parasitic resets.
2. The user must ensure that the level on the NRST pin can go below the $V_{IL(NRST)}$ max level specified in [Table 36](#). Otherwise the reset will not be taken into account by the device.

5.3.14 TIM timer characteristics

The parameters given in [Table 37](#) are guaranteed by design.

Refer to [Section 5.3.12: I/O port characteristics](#) for details on the input/output alternate function characteristics (output compare, input capture, external clock, PWM output).

Table 37. TIMx⁽¹⁾ characteristics

Symbol	Parameter	Conditions	Min	Max	Unit
$t_{res(TIM)}$	Timer resolution time		1		$t_{TIMxCLK}$
		$f_{TIMxCLK} = 48 \text{ MHz}$	20.84		ns
f_{EXT}	Timer external clock frequency on CH1 to CH4		0	$f_{TIMxCLK}/2$	MHz
		$f_{TIMxCLK} = 48 \text{ MHz}$	0	24	MHz
Res_{TIM}	Timer resolution			16	bit
$t_{COUNTER}$	16-bit counter clock period when internal clock is selected		1	65536	$t_{TIMxCLK}$
		$f_{TIMxCLK} = 48 \text{ MHz}$	0.0208	1365	μs
t_{MAX_COUNT}	Maximum possible count			65536×65536	$t_{TIMxCLK}$
		$f_{TIMxCLK} = 48 \text{ MHz}$		89.48	s

1. TIMx is used as a general term to refer to the TIM2, TIM3 and TIM4 timers.

5.3.15 Communications interfaces

I²C interface characteristics

Unless otherwise specified, the parameters given in [Table 38](#) are derived from tests performed under ambient temperature, f_{PCLK1} frequency and V_{DD} supply voltage conditions summarized in [Table 8](#).

The STM32F102xx medium-density USB access line I²C interface meets the requirements of the standard I²C communication protocol with the following restrictions: the I/O pins SDA and SCL are mapped to are not “true” open-drain. When configured as open-drain, the PMOS connected between the I/O pin and V_{DD} is disabled, but is still present.

The I²C characteristics are described in [Table 38](#). Refer also to [Section 5.3.12: I/O port characteristics](#) for more details on the input/output alternate function characteristics (SDA and SCL).

Table 38. I²C characteristics

Symbol	Parameter	Standard mode I ² C ⁽¹⁾		Fast mode I ² C ⁽¹⁾⁽²⁾		Unit
		Min	Max	Min	Max	
t _{w(SCLL)}	SCL clock low time	4.7		1.3		μs
t _{w(SCLH)}	SCL clock high time	4.0		0.6		
t _{su(SDA)}	SDA setup time	250		100		ns
t _{h(SDA)}	SDA data hold time	0 ⁽³⁾		0 ⁽⁴⁾	900 ⁽³⁾	
t _{r(SDA)} t _{r(SCL)}	SDA and SCL rise time		1000	20+0.1C _b	300	
t _{f(SDA)} t _{f(SCL)}	SDA and SCL fall time		300		300	
t _{h(STA)}	Start condition hold time	4.0		0.6		μs
t _{su(STA)}	Repeated Start condition setup time	4.7		0.6		
t _{su(STO)}	Stop condition setup time	4.0		0.6		μs
t _{w(STO:STA)}	Stop to Start condition time (bus free)	4.7		1.3		μs
C _b	Capacitive load for each bus line		400		400	pF

1. Values guaranteed by design, not tested in production.
2. f_{PCLK1} must be higher than 2 MHz to achieve the maximum standard mode I²C frequency. It must be higher than 4 MHz to achieve the maximum fast mode I²C frequency.
3. The maximum hold time of the Start condition has only to be met if the interface does not stretch the low period of SCL signal.
4. The device must internally provide a hold time of at least 300 ns for the SDA signal in order to bridge the undefined region of the falling edge of SCL.

Figure 21. I²C bus AC waveforms and measurement circuit⁽¹⁾

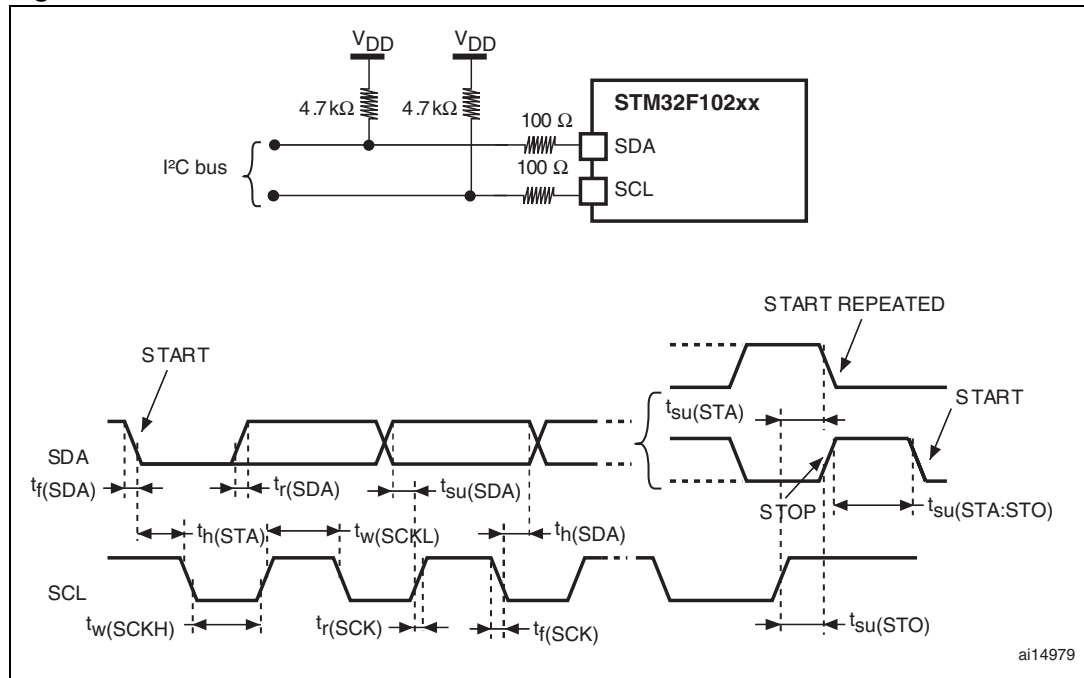

1. Measurement points are done at CMOS levels: 0.3V_{DD} and 0.7V_{DD}.

Table 39. SCL frequency (f_{PCLK1} = 24 MHz, V_{DD} = 3.3 V)⁽¹⁾⁽²⁾

f _{SCL} (kHz)	I2C_CCR value
	R _P = 4.7 kΩ
400	0x801E
300	0x8028
200	0x803C
100	0x00B4
50	0x0168
20	0x0384

1. R_P = External pull-up resistance, f_{SCL} = I²C speed,
2. For speeds around 200 kHz, the tolerance on the achieved speed is of ±5%. For other speed ranges, the tolerance on the achieved speed ±2%. These variations depend on the accuracy of the external components used to design the application.

SPI interface characteristics

Unless otherwise specified, the parameters given in [Table 40](#) are derived from tests performed under ambient temperature, f_{PCLKx} frequency and V_{DD} supply voltage conditions summarized in [Table 8](#).

Refer to [Section 5.3.12: I/O port characteristics](#) for more details on the input/output alternate function characteristics (NSS, SCK, MOSI, MISO).

Table 40. SPI characteristics⁽¹⁾

Symbol	Parameter	Conditions	Min	Max	Unit
f_{SCK} $1/t_{c(SCK)}$	SPI clock frequency	Master mode	0	12	MHz
		Slave mode	0	12	
$t_{r(SCK)}$ $t_{f(SCK)}$	SPI clock rise and fall time	Capacitive load: C = 30 pF		8	ns
$t_{su(NSS)}^{(2)}$	NSS setup time	Slave mode	$4 t_{PCLK}$		
$t_{h(NSS)}^{(2)}$	NSS hold time	Slave mode	73		
$t_{w(SCKH)}^{(2)}$ $t_{w(SCKL)}^{(2)}$	SCK high and low time	Master mode, $f_{PCLK} = 36$ MHz, presc = 4	50	60	
$t_{su(MI)}^{(2)}$	Data input setup time Master mode	SPI1	1		
		SPI2	5		
$t_{su(SI)}^{(2)}$	Data input setup time Slave mode		1		
$t_{h(MI)}^{(2)}$	Data input hold time Master mode	SPI1	1		
		SPI2	5		
$t_{h(SI)}^{(2)}$	Data input hold time Slave mode		3		
$t_{a(SO)}^{(2)(3)}$	Data output access time	Slave mode, $f_{PCLK} = 36$ MHz, presc = 4	0	55	
		Slave mode, $f_{PCLK} = 24$ MHz	0	$4 t_{PCLK}$	
$t_{dis(SO)}^{(2)(4)}$	Data output disable time	Slave mode	10		
$t_{v(SO)}^{(2)(1)}$	Data output valid time	Slave mode (after enable edge)		25	
$t_{v(MO)}^{(2)(1)}$	Data output valid time	Master mode (after enable edge)		3	
$t_{h(SO)}^{(2)}$	Data output hold time	Slave mode (after enable edge)	25		
$t_{h(MO)}^{(2)}$		Master mode (after enable edge)	4		

1. Remapped SPI1 characteristics to be determined.
2. Based on characterization, not tested in production.
3. Min time is for the minimum time to drive the output and the max time is for the maximum time to validate the data.
4. Min time is for the minimum time to invalidate the output and the max time is for the maximum time to put the data in Hi-Z

Figure 22. SPI timing diagram - slave mode and CPHA=0

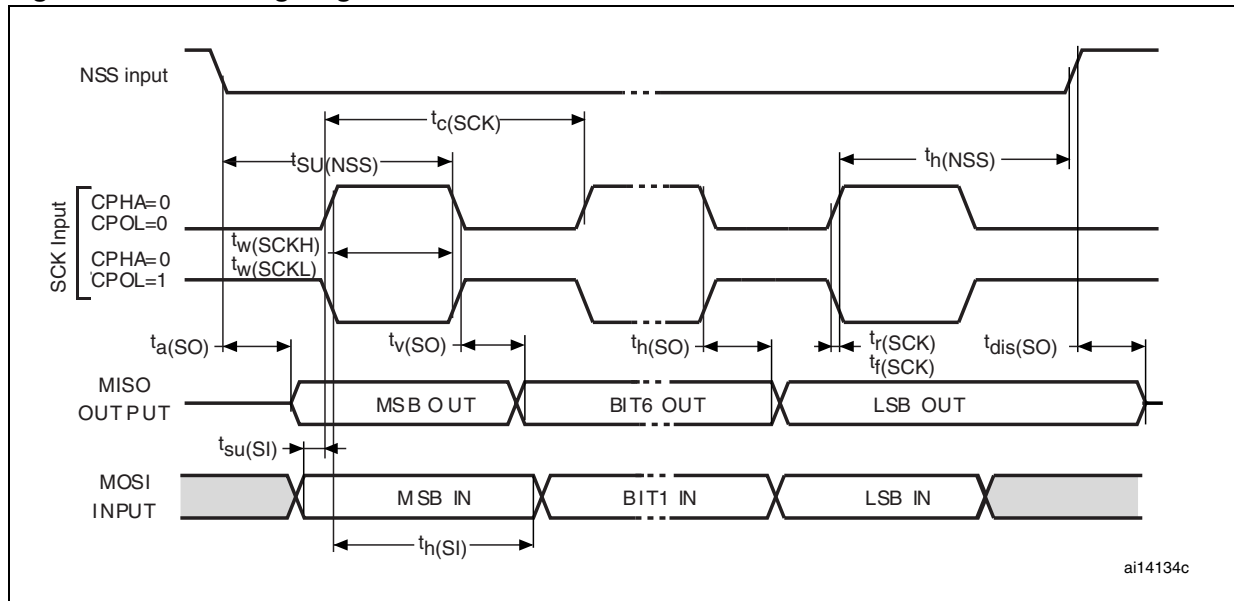
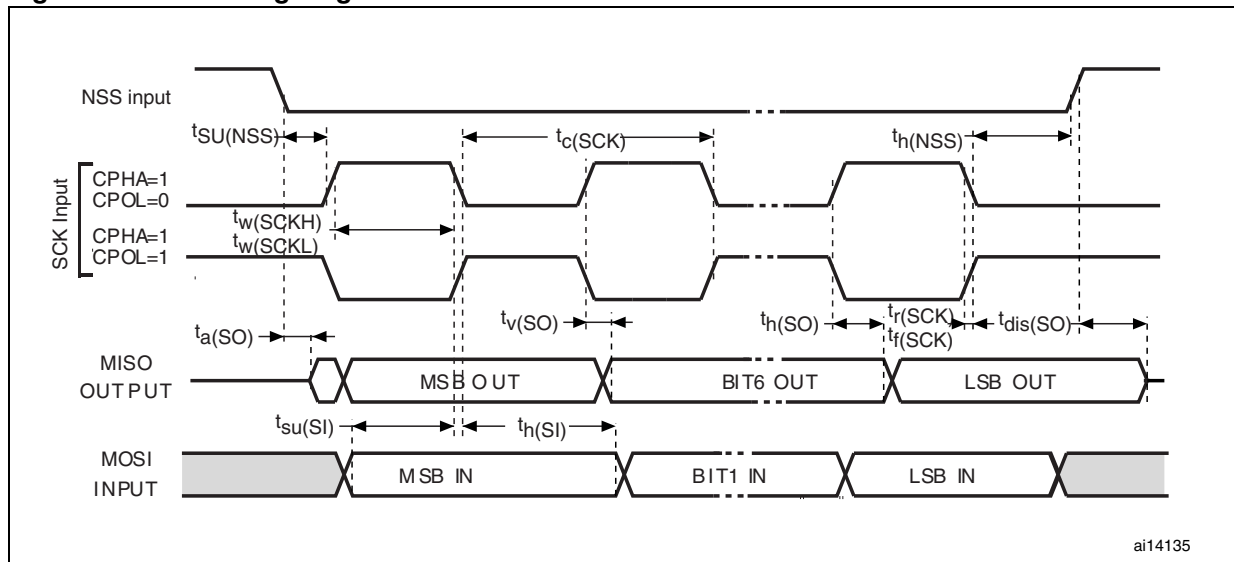
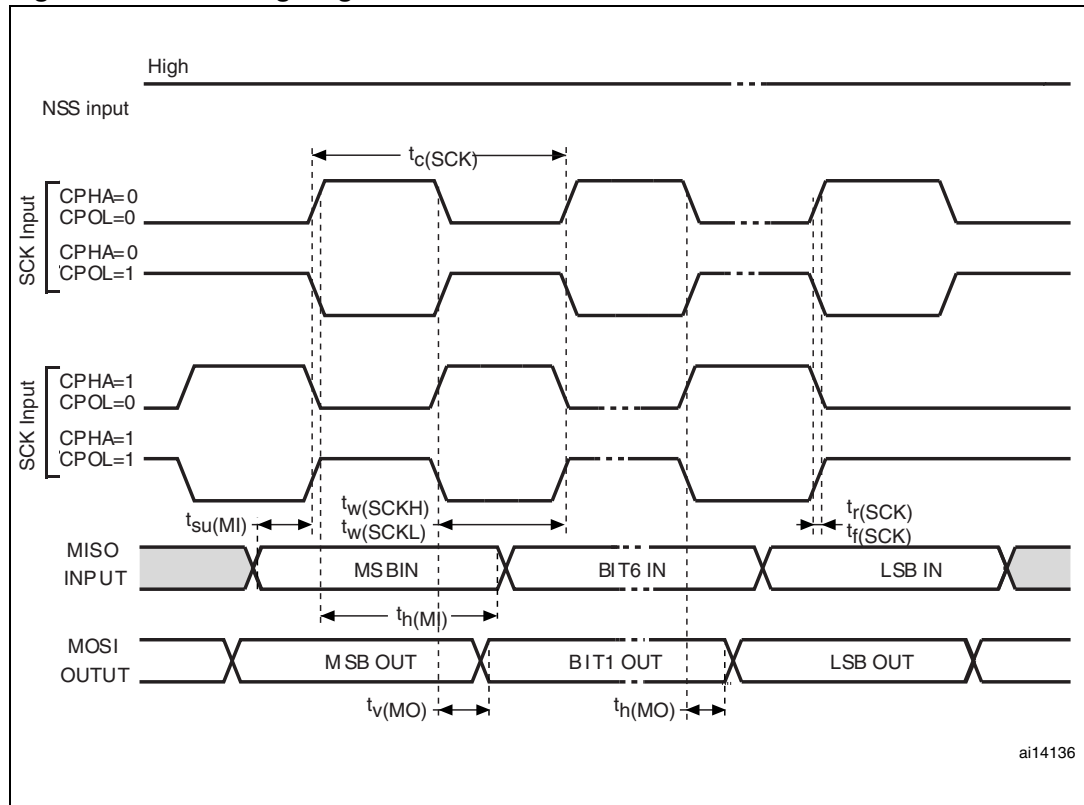

Figure 23. SPI timing diagram - slave mode and CPHA=1⁽¹⁾



1. Measurement points are done at CMOS levels: $0.3V_{DD}$ and $0.7V_{DD}$.

Figure 24. SPI timing diagram - master mode⁽¹⁾



1. Measurement points are done at CMOS levels: $0.3V_{DD}$ and $0.7V_{DD}$.

USB characteristics

The USB interface is USB-IF certified (Full Speed).

Table 41. USB startup time

Symbol	Parameter	Max	Unit
$t_{STARTUP}$	USB transceiver startup time	1	μs

Table 42. USB DC electrical characteristics

Symbol	Parameter	Conditions	Min. ⁽¹⁾	Max. ⁽¹⁾	Unit	
Input levels	V _{DD}	USB operating voltage ⁽²⁾		3.0 ⁽³⁾	3.6	V
	V _{DI} ⁽⁴⁾	Differential input sensitivity	I(USBDP, USBDM)	0.2		V
	V _{CM} ⁽⁴⁾	Differential common mode range	Includes V _{DI} range	0.8	2.5	
	V _{SE} ⁽⁴⁾	Single ended receiver threshold		1.3	2.0	
Output levels	V _{OL}	Static output level low	R _L of 1.5 kΩ to 3.6 V ⁽⁵⁾		0.3	V
	V _{OH}	Static output level high	R _L of 15 kΩ to V _{SS} ⁽⁵⁾	2.8	3.6	

1. All the voltages are measured from the local ground potential.
2. To be compliant with the USB 2.0 full-speed electrical specification, the USBDP (D+) pin should be pulled up with a 1.5 kΩ resistor to a 3.0-to-3.6 V voltage range.
3. The STM32F102xx USB functionality is ensured down to 2.7 V but not the full USB electrical characteristics which are degraded in the 2.7-to-3.0 V V_{DD} voltage range.
4. Guaranteed by design, not tested in production.
5. R_L is the load connected on the USB drivers

Figure 25. USB timings: definition of data signal rise and fall time

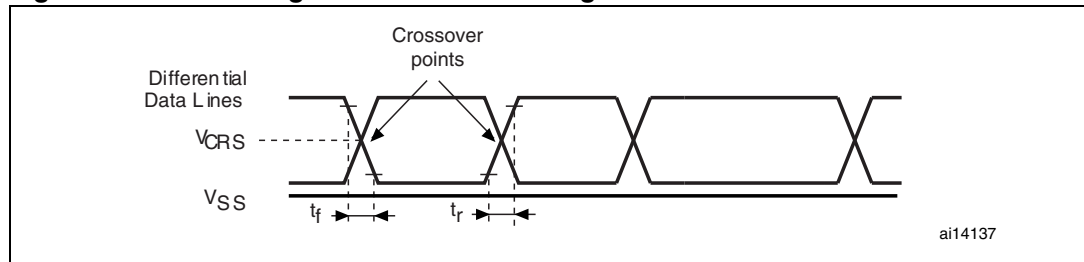

Table 43. USB: Full speed electrical characteristics of the driver⁽¹⁾

Symbol	Parameter	Conditions	Min	Max	Unit
t _r	Rise time ⁽²⁾	C _L = 50 pF	4	20	ns
t _f	Fall time ⁽²⁾	C _L = 50 pF	4	20	ns
t _{rfm}	Rise/ fall time matching	t _r /t _f	90	110	%
V _{CRS}	Output signal crossover voltage		1.3	2.0	V

1. Guaranteed by design, not tested in production.
2. Measured from 10% to 90% of the data signal. For more detailed informations, please refer to USB Specification - Chapter 7 (version 2.0).

5.3.16 12-bit ADC characteristics

Unless otherwise specified, the parameters given in [Table 44](#) are derived from tests performed under ambient temperature, f_{PCLK2} frequency and V_{DDA} supply voltage conditions summarized in [Table 8](#).

Note: It is recommended to perform a calibration after each power-up.

Table 44. ADC characteristics

Symbol	Parameter	Conditions	Min	Typ	Max	Unit
V _{DDA}	Power supply		2.4		3.6	V
f _{ADC}	ADC clock frequency		0.6		12	MHz
f _S ⁽¹⁾	Sampling rate		0.05		1	MHz
f _{TRIG} ⁽¹⁾	External trigger frequency	f _{ADC} = 12 MHz			823	kHz
					17	1/f _{ADC}
V _{AIN}	Conversion voltage range ⁽²⁾		0 (V _{SSA} or V _{REF-} tied to ground)		V _{REF+}	V
R _{AIN} ⁽¹⁾	External input impedance		See Equation 1 and Table 45			kΩ
R _{ADC} ⁽¹⁾	Sampling switch resistance				1	kΩ
C _{ADC} ⁽¹⁾	Internal sample and hold capacitor				12	pF
t _{CAL} ⁽¹⁾	Calibration time	f _{ADC} = 12 MHz	5.9			μs
			83			1/f _{ADC}
t _{lat} ⁽¹⁾	Injection trigger conversion latency	f _{ADC} = 12 MHz			0.214	μs
					3 ⁽³⁾	1/f _{ADC}
t _{latr} ⁽¹⁾	Regular trigger conversion latency	f _{ADC} = 12 MHz			0.143	μs
					2 ⁽³⁾	1/f _{ADC}
t _S ⁽¹⁾	Sampling time	f _{ADC} = 12 MHz	0.107		17.1	μs
			1.5		239.5	1/f _{ADC}
t _{STAB} ⁽¹⁾	Power-up time		0	0	1	μs
t _{CONV} ⁽¹⁾	Total conversion time (including sampling time)	f _{ADC} = 12 MHz	1.2		18	μs
			14 to 252 (t _S for sampling + 12.5 for successive approximation)			1/f _{ADC}

1. Guaranteed by design, not tested in production.
2. V_{REF+} is internally connected to V_{DDA} and V_{REF-} is internally connected to V_{SSA}.
3. For external triggers, a delay of 1/f_{PCLK2} must be added to the latency specified in [Table 44](#).

Equation 1: R_{AIN} max formula:

$$R_{AIN} < \frac{T_S}{f_{ADC} \times C_{ADC} \times \ln(2^{N+2})} - R_{ADC}$$

The formula above ([Equation 1](#)) is used to determine the maximum external impedance allowed for an error below 1/4 of LSB. Here N = 12 (from 12-bit resolution).

Table 45. R_{AIN} max for $f_{ADC} = 12\text{ MHz}^{(1)}$

T_s (cycles)	t_s (μs)	R_{AIN} max ($\text{k}\Omega$)
1.5	0.13	1.6
7.5	0.63	12
13.5	1.13	22
28.5	2.38	48
41.5	3.46	70
55.5	4.63	95
71.5	5.96	122
239.5	19.96	410

1. Data guaranteed by design, not tested in production.

Table 46. ADC accuracy - limited test conditions⁽¹⁾

Symbol	Parameter	Test conditions	Typ	Max ⁽²⁾	Unit
ET	Total unadjusted error	$f_{PCLK2} = 48\text{ MHz}$, $f_{ADC} = 12\text{ MHz}$, $R_{AIN} < 10\text{ k}\Omega$, $V_{DDA} = 3\text{ V to } 3.6\text{ V}$ $T_A = 25\text{ }^\circ\text{C}$ Measurements made after ADC calibration	± 1.3	± 2	LSB
EO	Offset error		± 1	± 1.5	
EG	Gain error		± 0.5	± 1.5	
ED	Differential linearity error		± 0.7	± 1	
EL	Integral linearity error		± 0.8	± 1.5	

1. ADC DC accuracy values are measured after internal calibration.

2. Based on characterization, not tested in production.

Table 47. ADC accuracy^{(1) (2)}

Symbol	Parameter	Test conditions	Typ	Max ⁽³⁾	Unit
ET	Total unadjusted error	$f_{PCLK2} = 48\text{ MHz}$, $f_{ADC} = 12\text{ MHz}$, $R_{AIN} < 10\text{ k}\Omega$, $V_{DDA} = 2.4\text{ V to } 3.6\text{ V}$ Measurements made after ADC calibration	± 2	± 5	LSB
EO	Offset error		± 1.5	± 2.5	
EG	Gain error		± 1.5	± 3	
ED	Differential linearity error		± 1	± 2	
EL	Integral linearity error		± 1.5	± 3	

1. ADC DC accuracy values are measured after internal calibration.

2. Better performance could be achieved in restricted V_{DD} , frequency and temperature ranges.

3. Based on characterization, not tested in production.

Note: *ADC accuracy vs. negative injection current: Injecting a negative current on any of the standard (non-robust) analog pins should be avoided as this significantly reduces the accuracy of the conversion being performed on another analog pin. It is recommended to add a Schottky diode (pin to ground) to standard analog pins that may potentially inject negative current.*

Any positive injection current within the limits specified for $I_{INJ(PIN)}$ and $\Sigma I_{INJ(PIN)}$ in Section 5.3.12 does not affect the ADC accuracy.

Figure 26. ADC accuracy characteristics

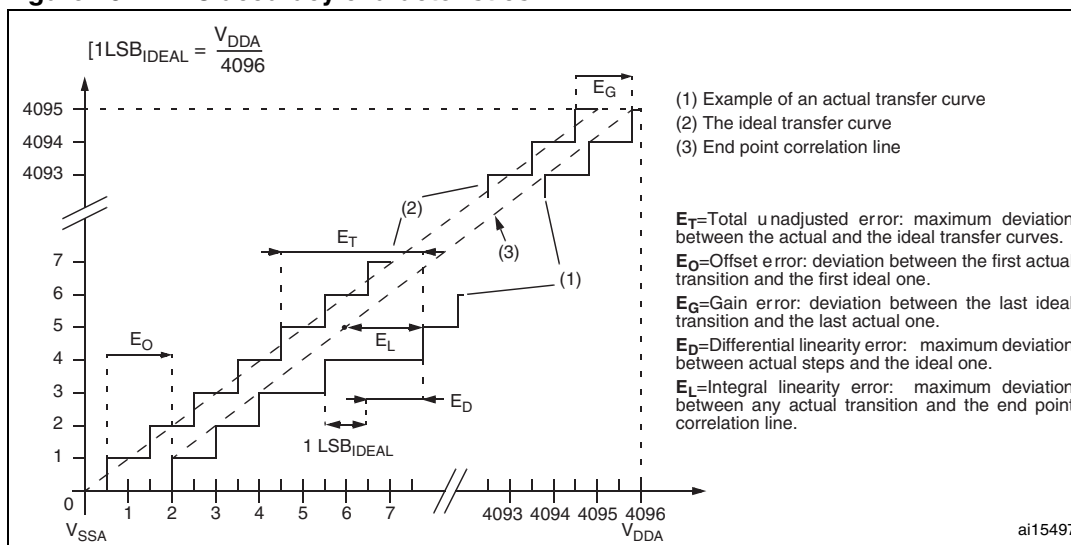
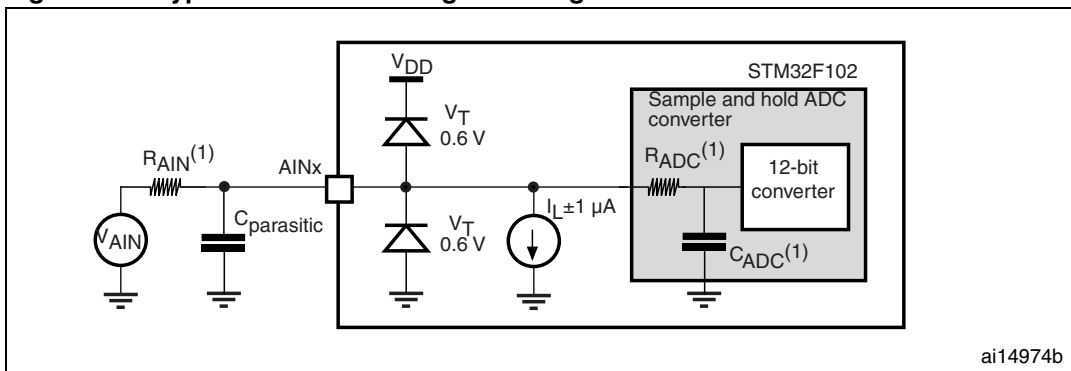

Figure 27. Typical connection diagram using the ADC



1. Refer to [Table 44](#) for the values of R_{AIN} , R_{ADC} and C_{ADC} .
2. $C_{parasitic}$ represents the capacitance of the PCB (dependent on soldering and PCB layout quality) plus the pad capacitance (roughly 7 pF). A high $C_{parasitic}$ value will downgrade conversion accuracy. To remedy this, f_{ADC} should be reduced.

General PCB design guidelines

Power supply decoupling should be performed as shown in *Figure 28*. The 10 nF capacitors should be ceramic (good quality). They should be placed as close as possible to the chip.

Figure 28. Power supply and reference decoupling

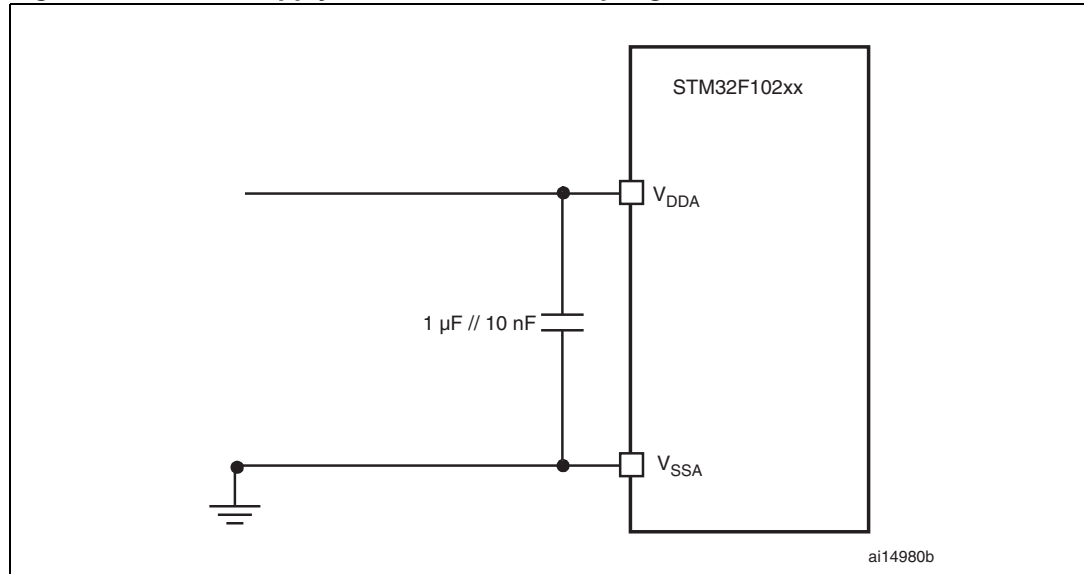

5.3.17 Temperature sensor characteristics

Table 48. TS characteristics

Symbol	Parameter	Min	Typ	Max	Unit
$T_L^{(1)}$	V_{SENSE} linearity with temperature		± 1.5		$^{\circ}C$
$Avg_Slope^{(1)}$	Average slope		4.35		mV/ $^{\circ}C$
$V_{25}^{(1)}$	Voltage at 25 $^{\circ}C$		1.42		V
$t_{START}^{(2)}$	Startup time	4		10	μs
$T_{S_temp}^{(3)(2)}$	ADC sampling time when reading the temperature			17.1	μs

1. Guaranteed by characterization, not tested in production.
2. Data guaranteed by design, not tested in production.
3. Shortest sampling time can be determined in the application by multiple iterations.

6 Package characteristics

6.1 Package mechanical data

In order to meet environmental requirements, ST offers these devices in different grades of ECOPACK[®] packages, depending on their level of environmental compliance. ECOPACK[®] specifications, grade definitions and product status are available at: www.st.com. ECOPACK[®] is an ST trademark.

Figure 29. LQFP64 – 64 pin low-profile quad flat package outline⁽¹⁾ Figure 30. Recommended footprint⁽¹⁾⁽²⁾

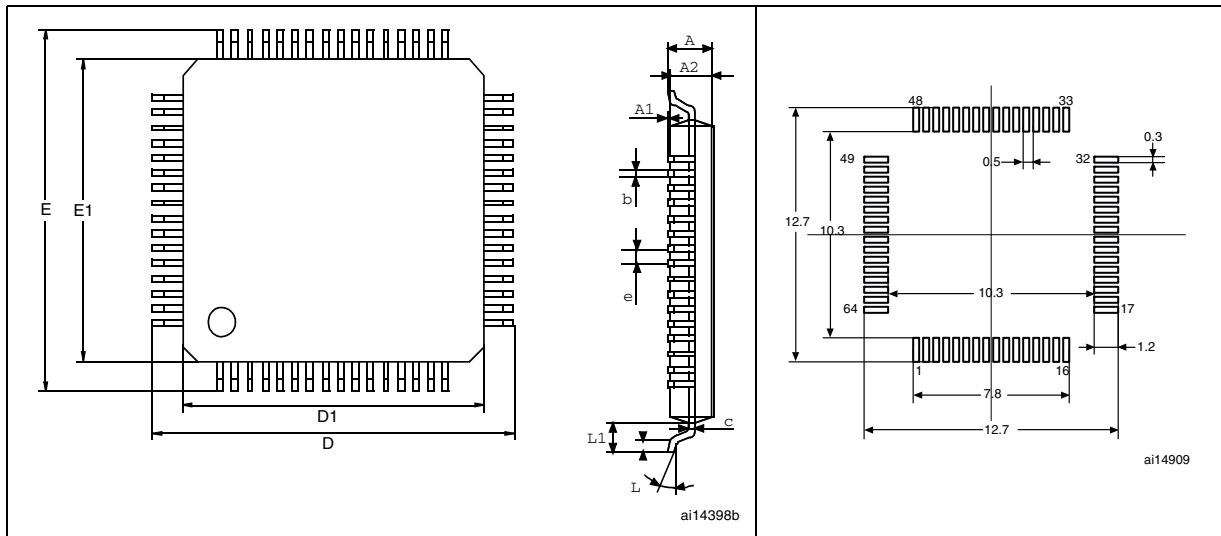

1. Drawing is not to scale.
2. Dimensions are in millimeters.

Table 49. LQFP64 – 64-pin low-profile quad flat package mechanical data

Dim.	mm			inches ⁽¹⁾		
	Min	Typ	Max	Min	Typ	Max
A			1.60			0.0630
A1	0.05		0.15	0.0020		0.0059
A2	1.35	1.40	1.45	0.0531	0.0551	0.0571
b	0.17	0.22	0.27	0.0067	0.0087	0.0106
c	0.09		0.20	0.0035		0.0079
D		12.00			0.4724	
D1		10.00			0.3937	
E		12.00			0.4724	
E1		10.00			0.3937	
e		0.50			0.0197	
θ	0°	3.5°	7°	0°	3.5°	7°
L	0.45	0.60	0.75	0.0177	0.0236	0.0295
L1		1.00			0.0394	
Number of pins						
N	64					

1. Values in inches are converted from mm and rounded to 4 decimal digits.

Figure 31. LQFP48 – 48-pin low-profile quad flat package outline⁽¹⁾

Figure 32. Recommended footprint⁽¹⁾⁽²⁾

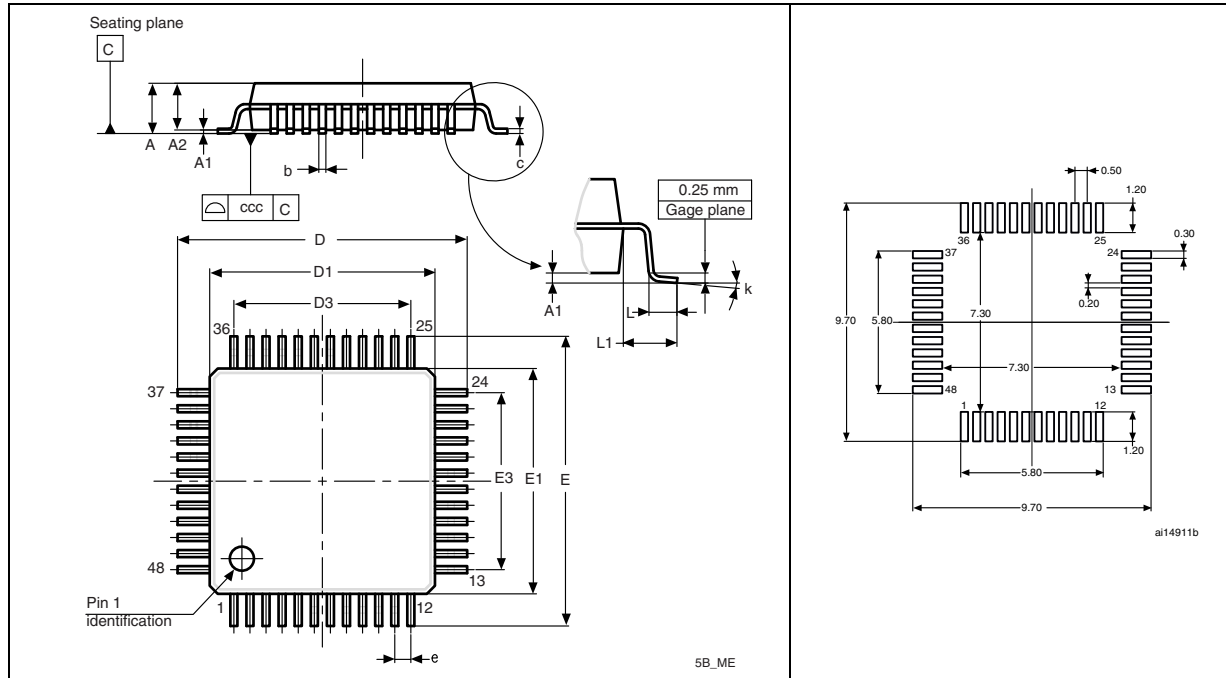

1. Drawing is not to scale.
2. Dimensions are in millimeters.

Table 50. LQFP48 – 48-pin low-profile quad flat package mechanical data

Symbol	millimeters			inches ⁽¹⁾		
	Typ	Min	Max	Typ	Min	Max
A			1.600			0.0630
A1		0.050	0.150		0.0020	0.0059
A2	1.400	1.350	1.450	0.0551	0.0531	0.0571
b	0.220	0.170	0.270	0.0087	0.0067	0.0106
c		0.090	0.200		0.0035	0.0079
D	9.000	8.800	9.200	0.3543	0.3465	0.3622
D1	7.000	6.800	7.200	0.2756	0.2677	0.2835
D3	5.500			0.2165		
E	9.000	8.800	9.200	0.3543	0.3465	0.3622
E1	7.000	6.800	7.200	0.2756	0.2677	0.2835
E3	5.500			0.2165		
e	0.500			0.0197		
L	0.600	0.450	0.750	0.0236	0.0177	0.0295
L1	1.000			0.0394		
k	3.5°	0°	7°	3.5°	0°	7°
ccc		0.080			0.0031	

1. Values in inches are converted from mm and rounded to 4 decimal digits.

6.2 Thermal characteristics

The maximum chip junction temperature (T_J max) must never exceed the values given in [Table 8: General operating conditions on page 27](#).

The maximum chip-junction temperature, T_J max, in degrees Celsius, may be calculated using the following equation:

$$T_J \text{ max} = T_A \text{ max} + (P_D \text{ max} \times \Theta_{JA})$$

Where:

- T_A max is the maximum ambient temperature in °C,
- Θ_{JA} is the package junction-to-ambient thermal resistance, in °C/W,
- P_D max is the sum of P_{INT} max and $P_{I/O}$ max (P_D max = P_{INT} max + $P_{I/O}$ max),
- P_{INT} max is the product of I_{DD} and V_{DD} , expressed in Watts. This is the maximum chip internal power.

$P_{I/O}$ max represents the maximum power dissipation on output pins where:

$$P_{I/O} \text{ max} = \Sigma (V_{OL} \times I_{OL}) + \Sigma ((V_{DD} - V_{OH}) \times I_{OH}),$$

taking into account the actual V_{OL} / I_{OL} and V_{OH} / I_{OH} of the I/Os at low and high level in the application.

Table 51. Package thermal characteristics

Symbol	Parameter	Value	Unit
Θ_{JA}	Thermal resistance junction-ambient LQFP48 - 7 × 7 mm / 0.5 mm pitch	55	°C/W
	Thermal resistance junction-ambient LQFP64 - 10 × 10 mm / 0.5 mm pitch	45	

6.3 Reference document

JESD51-2 Integrated Circuits Thermal Test Method Environment Conditions - Natural Convection (Still Air). Available from www.jedec.org.

6.3.1 Evaluating the maximum junction temperature for an application

When ordering the microcontroller, the temperature range is specified in the ordering information scheme shown in [Table 52: Ordering information scheme](#).

Each temperature range suffix corresponds to a specific guaranteed ambient temperature at maximum dissipation and, to a specific maximum junction temperature. Here, only temperature range 6 is available (−40 to 85 °C).

The following example shows how to calculate the temperature range needed for a given application, making it possible to check whether the required temperature range is compatible with the STM32F102xx junction temperature range.

Example: High-performance application

Assuming the following application conditions:

Maximum ambient temperature $T_{Amax} = 82\text{ °C}$ (measured according to JESD51-2),
 $I_{DDmax} = 50\text{ mA}$, $V_{DD} = 3.5\text{ V}$, maximum 20 I/Os used at the same time in output at low level with $I_{OL} = 8\text{ mA}$, $V_{OL} = 0.4\text{ V}$ and maximum 8 I/Os used at the same time in output mode at low level with $I_{OL} = 20\text{ mA}$, $V_{OL} = 1.3\text{ V}$

$$P_{INTmax} = 50\text{ mA} \times 3.5\text{ V} = 175\text{ mW}$$

$$P_{IOmax} = 20 \times 8\text{ mA} \times 0.4\text{ V} + 8 \times 20\text{ mA} \times 1.3\text{ V} = 272\text{ mW}$$

This gives: $P_{INTmax} = 175\text{ mW}$ and $P_{IOmax} = 272\text{ mW}$

$$P_{Dmax} = 175 + 272 = 447\text{ mW}$$

Thus: $P_{Dmax} = 447\text{ mW}$

Using the values obtained in [Table 51](#) T_{Jmax} is calculated as follows:

– For LQFP64, 45 °C/W

$$T_{Jmax} = 82\text{ °C} + (45\text{ °C/W} \times 447\text{ mW}) = 82\text{ °C} + 20.1\text{ °C} = 102.1\text{ °C}$$

This is within the junction temperature range of the STM32F102xx (−40 < T_J < 105 °C).

Figure 33. LQFP64 P_D max vs. T_A

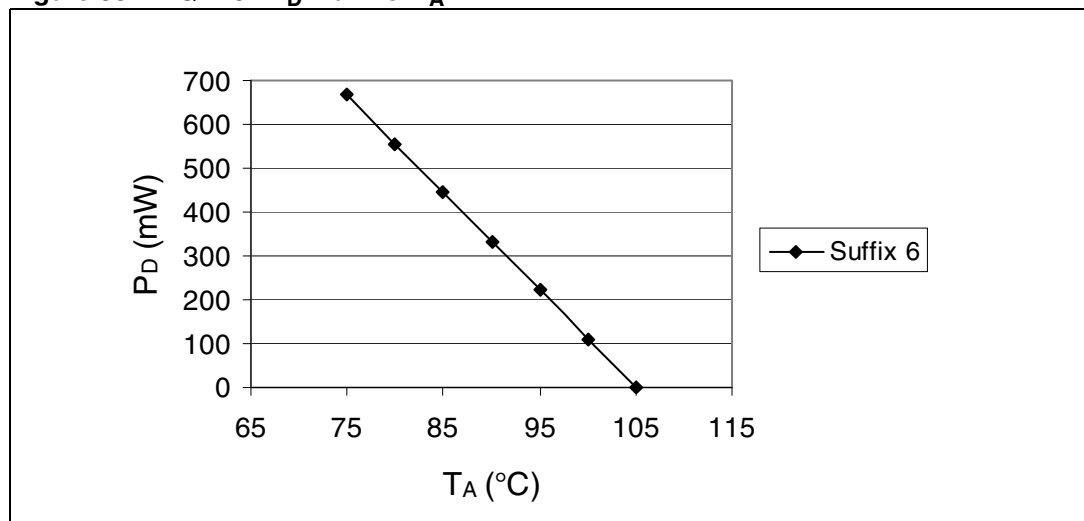

7 Ordering information scheme

Table 52. Ordering information scheme

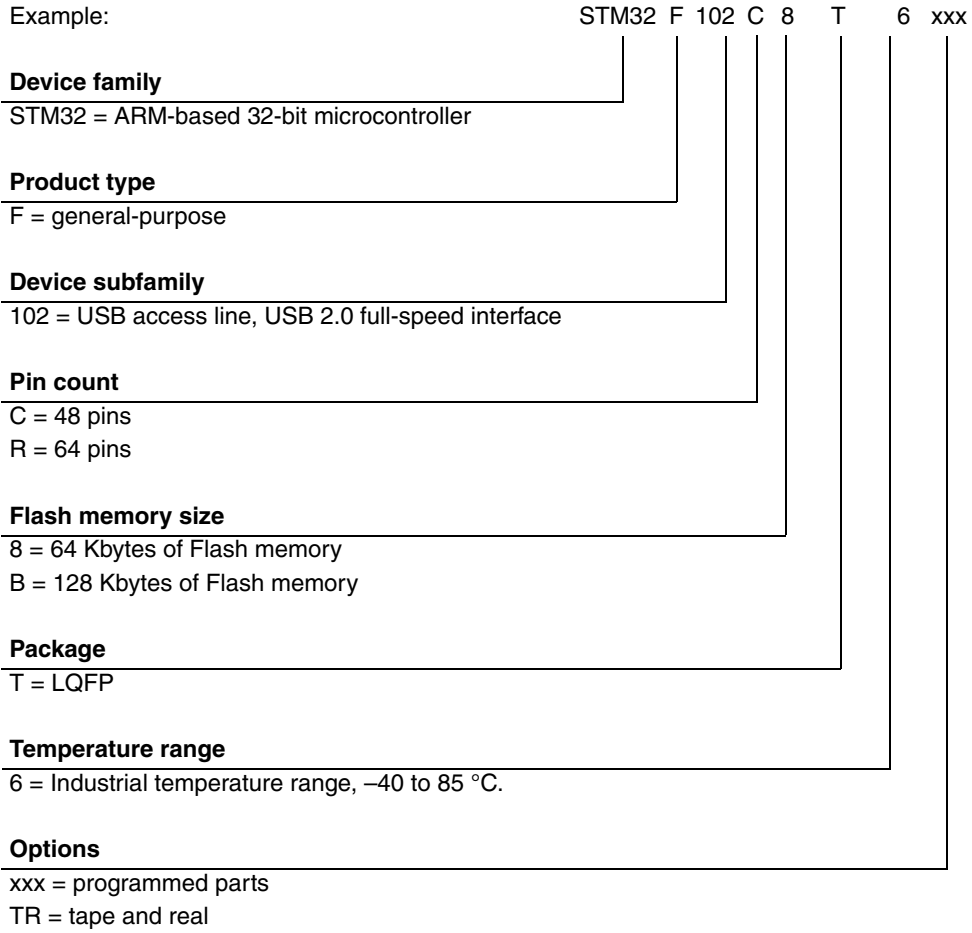

8 Revision history

Table 53. Document revision history

Date	Revision	Changes
23-Sep-2008	1	Initial release.
23-Apr-2009	2	<p>I/O information clarified <i>on page 1. Figure 1: STM32F102xx medium-density USB access line block diagram</i> and <i>Figure 5: Memory map</i> modified.</p> <p>In <i>Table 4: Medium-density STM32F102xx pin definitions</i>: PB4, PB13, PB14, PB15, PB3/TRACESWO moved from Default column to Remap column.</p> <p>P_D value added for LQFP64 package in <i>Table 8: General operating conditions</i>.</p> <p>Note modified in <i>Table 12: Maximum current consumption in Run mode, code with data processing running from Flash</i> and <i>Table 14: Maximum current consumption in Sleep mode, code running from Flash or RAM</i>. <i>Figure 12, Figure 13</i> and <i>Figure 14</i> show typical curves.</p> <p><i>Figure 26: ADC accuracy characteristics</i> modified.</p> <p><i>Figure 28: Power supply and reference decoupling</i> modified.</p> <p><i>Table 19: High-speed external user clock characteristics</i> and <i>Table 20: Low-speed external user clock characteristics</i> modified.</p> <p>ACC_{HSI} max values modified in <i>Table 23: HSI oscillator characteristics</i>.</p> <p>Small text changes.</p>

Please Read Carefully:

Information in this document is provided solely in connection with ST products. STMicroelectronics NV and its subsidiaries ("ST") reserve the right to make changes, corrections, modifications or improvements, to this document, and the products and services described herein at any time, without notice.

All ST products are sold pursuant to ST's terms and conditions of sale.

Purchasers are solely responsible for the choice, selection and use of the ST products and services described herein, and ST assumes no liability whatsoever relating to the choice, selection or use of the ST products and services described herein.

No license, express or implied, by estoppel or otherwise, to any intellectual property rights is granted under this document. If any part of this document refers to any third party products or services it shall not be deemed a license grant by ST for the use of such third party products or services, or any intellectual property contained therein or considered as a warranty covering the use in any manner whatsoever of such third party products or services or any intellectual property contained therein.

UNLESS OTHERWISE SET FORTH IN ST'S TERMS AND CONDITIONS OF SALE ST DISCLAIMS ANY EXPRESS OR IMPLIED WARRANTY WITH RESPECT TO THE USE AND/OR SALE OF ST PRODUCTS INCLUDING WITHOUT LIMITATION IMPLIED WARRANTIES OF MERCHANTABILITY, FITNESS FOR A PARTICULAR PURPOSE (AND THEIR EQUIVALENTS UNDER THE LAWS OF ANY JURISDICTION), OR INFRINGEMENT OF ANY PATENT, COPYRIGHT OR OTHER INTELLECTUAL PROPERTY RIGHT.

UNLESS EXPRESSLY APPROVED IN WRITING BY AN AUTHORIZED ST REPRESENTATIVE, ST PRODUCTS ARE NOT RECOMMENDED, AUTHORIZED OR WARRANTED FOR USE IN MILITARY, AIR CRAFT, SPACE, LIFE SAVING, OR LIFE SUSTAINING APPLICATIONS, NOR IN PRODUCTS OR SYSTEMS WHERE FAILURE OR MALFUNCTION MAY RESULT IN PERSONAL INJURY, DEATH, OR SEVERE PROPERTY OR ENVIRONMENTAL DAMAGE. ST PRODUCTS WHICH ARE NOT SPECIFIED AS "AUTOMOTIVE GRADE" MAY ONLY BE USED IN AUTOMOTIVE APPLICATIONS AT USER'S OWN RISK.

Resale of ST products with provisions different from the statements and/or technical features set forth in this document shall immediately void any warranty granted by ST for the ST product or service described herein and shall not create or extend in any manner whatsoever, any liability of ST.

ST and the ST logo are trademarks or registered trademarks of ST in various countries.

Information in this document supersedes and replaces all information previously supplied.

The ST logo is a registered trademark of STMicroelectronics. All other names are the property of their respective owners.

© 2009 STMicroelectronics - All rights reserved

STMicroelectronics group of companies

Australia - Belgium - Brazil - Canada - China - Czech Republic - Finland - France - Germany - Hong Kong - India - Israel - Italy - Japan - Malaysia - Malta - Morocco - Philippines - Singapore - Spain - Sweden - Switzerland - United Kingdom - United States of America

www.st.com

