



STP30NF20 - STB30NF20 STW30NF20

N-channel 200V - 0.065Ω - 30A - TO-220/TO-247/D²PAK
Low gate charge STripFET™ Power MOSFET

Features

Type	V _{DSS}	R _{DS(on)}	I _D	P _{TOT}
STP30NF20	200V	0.075Ω	30A	125W
STW30NF20	200V	0.075Ω	30A	125W
STB30NF20	200V	0.075Ω	30A	125W

- Gate charge minimized
- 100% avalanche tested
- Excellent figure of merit (R_{DS}*Q_g)
- Very good manufacturing repeability
- Very low intrinsic capacitances

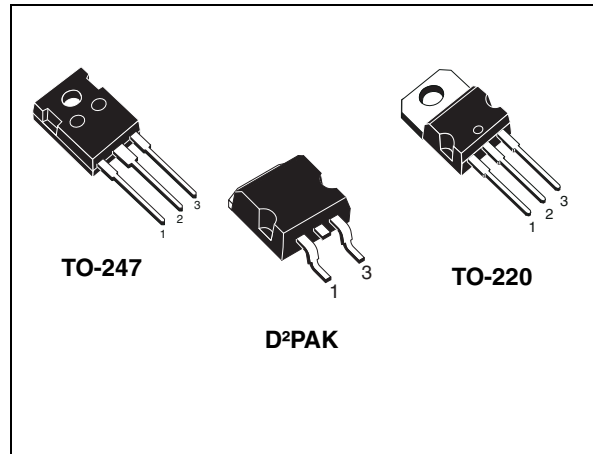

Application

- Switching applications

Description

This Power MOSFET series realized with STMicroelectronics unique STripFET process has specifically been designed to minimize input capacitance and gate charge. It is therefore suitable as primary switch in advanced high-efficiency isolated DC-DC converters.

Figure 1. Internal schematic diagram

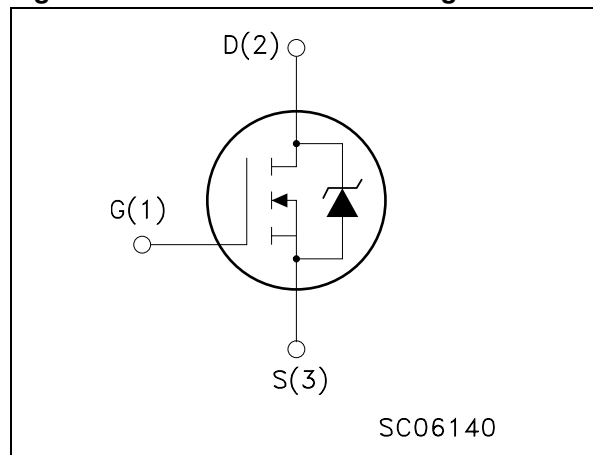

Table 1. Device summary

Order codes	Marking	Package	Packaging
STP30NF20	30NF20	TO-220	Tube
STW30NF20	30NF20	TO-247	Tube
STB30NF20	30NF20	D ² PAK	Tape & reel

Contents

1	Electrical ratings	3
2	Electrical characteristics	4
2.1	Electrical characteristics (curves)	6
3	Test circuit	9
4	Package mechanical data	10
5	Packaging mechanical data	14
6	Revision history	15

1 Electrical ratings

Table 2. Absolute maximum ratings

Symbol	Parameter	Value	Unit
V_{DS}	Drain-source voltage ($V_{GS} = 0$)	200	V
V_{GS}	Gate-source voltage	± 20	V
I_D	Drain current (continuous) at $T_C = 25^\circ\text{C}$	30	A
I_D	Drain current (continuous) at $T_C = 100^\circ\text{C}$	19	A
$I_{DM}^{(1)}$	Drain current (pulsed)	120	A
P_{TOT}	Total dissipation at $T_C = 25^\circ\text{C}$	125	W
	Derating factor	1	W/ $^\circ\text{C}$
$dv/dt^{(2)}$	Peak diode recovery voltage slope	10	V/ns
T_J T_{stg}	Operating junction temperature Storage temperature	-55 to 150	$^\circ\text{C}$
T_l	Maximum lead temperature for soldering purpose	300	$^\circ\text{C}$

1. Pulse width limited by safe operating area
2. $I_{SD} \leq 30\text{A}$, $di/dt \leq 200\text{A}/\mu\text{s}$, $V_{DD} = 80\%V_{(BR)DSS}$

Table 3. Thermal data

Symbol	Parameter	TO-220/ D ² PAK	TO-247	Unit
R_{thJC}	Thermal resistance junction-case max	1		$^\circ\text{C}/\text{W}$
R_{thJA}	Thermal resistance junction-ambient max	62.5	50	$^\circ\text{C}/\text{W}$

Table 4. Avalanche data

Symbol	Parameter	Value	Unit
I_{AR}	Avalanche current, repetitive or not repetitive (pulse width limited by T_{jmax})	30	A
E_{AS}	Single pulse avalanche energy (starting $T_J = 25^\circ\text{C}$, $I_D = I_{AR}$, $V_{DD} = 50\text{V}$)	140	mJ

2 Electrical characteristics

($T_{CASE}=25^{\circ}C$ unless otherwise specified)

Table 5. On/off states

Symbol	Parameter	Test conditions	Min.	Typ.	Max.	Unit
$V_{(BR)DSS}$	Drain-source breakdown voltage	$I_D = 1mA, V_{GS} = 0$	200			V
I_{DSS}	Zero gate voltage drain current ($V_{GS} = 0$)	$V_{DS} = \text{Max rating},$ $V_{DS} = \text{Max rating}, T_c = 125^{\circ}C$			1 10	μA μA
I_{GSS}	Gate body leakage current ($V_{DS} = 0$)	$V_{GS} = \pm 20V$			± 100	nA
$V_{GS(th)}$	Gate threshold voltage	$V_{DS} = V_{GS}, I_D = 250\mu A$	2	3	4	V
$R_{DS(on)}$	Static drain-source on resistance	$V_{GS} = 10V, I_D = 15A$		0.065	0.075	Ω

Table 6. Dynamic

Symbol	Parameter	Test conditions	Min.	Typ.	Max.	Unit
$g_{fs}^{(1)}$	Forward transconductance	$V_{DS} = 15V, I_D = 15A$		20		S
C_{iss}	Input capacitance	$V_{DS} = 25V, f = 1\text{ MHz}, V_{GS} = 0$		1597		pF
C_{oss}	Output capacitance			320		pF
C_{rss}	Reverse transfer capacitance			43		pF
Q_g	Total gate charge	$V_{DD} = 160V, I_D = 30A$		38		nC
Q_{gs}	Gate-source charge	$V_{GS} = 10V$		8		nC
Q_{gd}	Gate-drain charge	(see Figure 17)		18		nC

1. Pulsed: pulse duration=300 μs , duty cycle 1.5%

Table 7. Switching times

Symbol	Parameter	Test conditions	Min.	Typ.	Max.	Unit
$t_{d(on)}$ t_r	Turn-on delay time Rise time	$V_{DD}=100V$, $I_D=15A$, $R_G=4.7\Omega$, $V_{GS}=10V$ (see Figure 16)		35 15.7		ns ns
$t_{d(off)}$ t_f	Turn-off delay time Fall time	$V_{DD}=100V$, $I_D=15A$, $R_G=4.7\Omega$, $V_{GS}=10V$ (see Figure 16)		38 8.8		ns ns

Table 8. Source drain diode

Symbol	Parameter	Test conditions	Min.	Typ.	Max.	Unit
I_{SD} $I_{SDM}^{(1)}$	Source-drain current Source-drain current (pulsed)				30 120	A A
$V_{SD}^{(2)}$	Forward on voltage	$I_{SD}=30A$, $V_{GS}=0$			1.5	V
t_{rr} Q_{rr} I_{RRM}	Reverse recovery time Reverse recovery charge Reverse recovery current	$I_{SD}=30A$, $di/dt = 100A/\mu s$, $V_{DD}=100V$, $T_j=25^\circ C$		155 0.96 12.4		ns μC A
t_{rr} Q_{rr} I_{RRM}	Reverse recovery time Reverse recovery charge Reverse recovery current	$I_{SD}=30A$, $di/dt = 100A/\mu s$, $V_{DD}=100V$, $T_j=150^\circ C$		194 1.42 14.6		ns μC A

1. Pulse width limited by safe operating area
2. Pulsed: pulse duration=300 μs , duty cycle 1.5%

2.1 Electrical characteristics (curves)

Figure 2. Safe operating area for TO-247

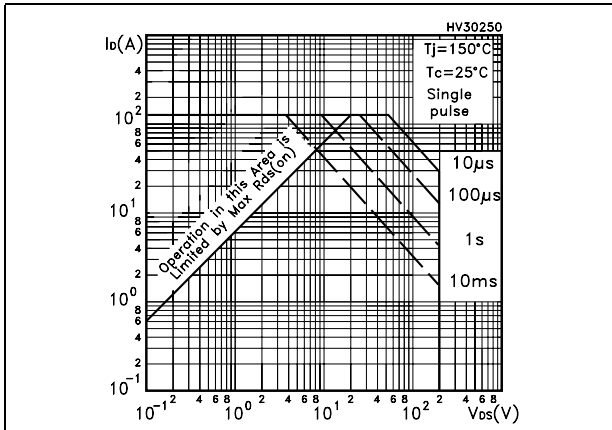

Figure 3. Thermal impedance for TO-247

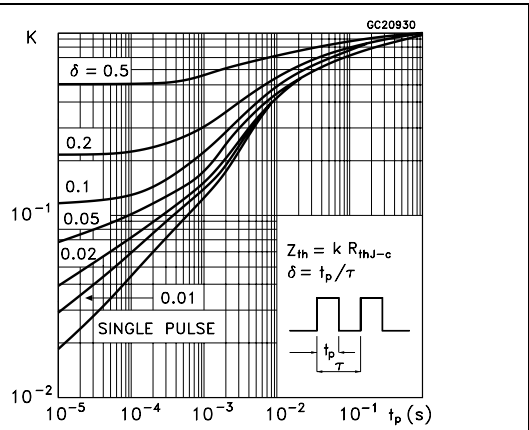

Figure 4. Safe operating area for TO-220/D²PAK

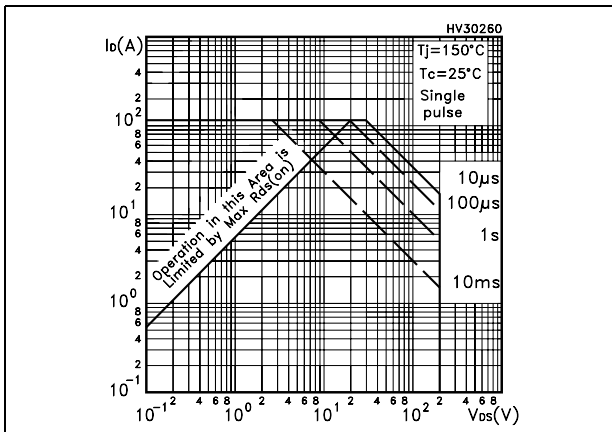

Figure 5. Thermal impedance for TO-220/D²PAK

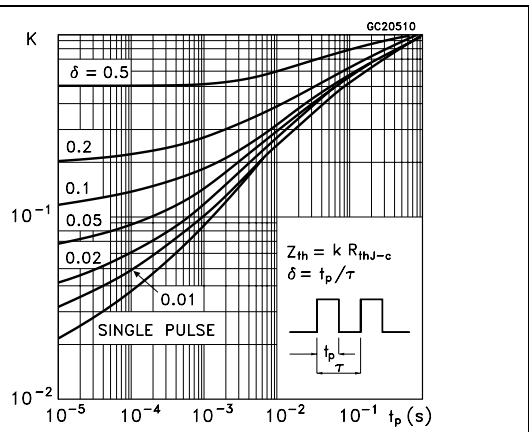

Figure 6. Output characteristics

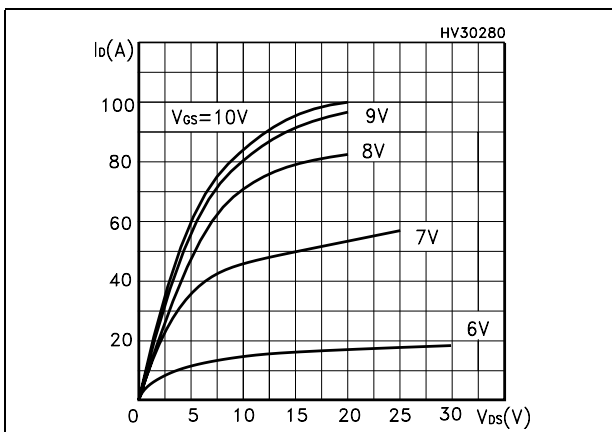

Figure 7. Transfer characteristics

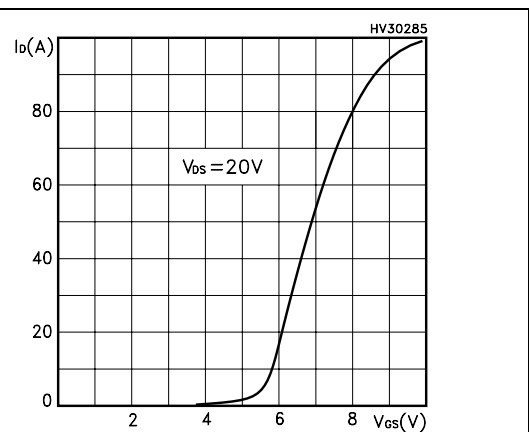

Figure 8. Normalized $B_{V_{DSS}}$ vs temperature

Figure 9. Static drain-source on resistance

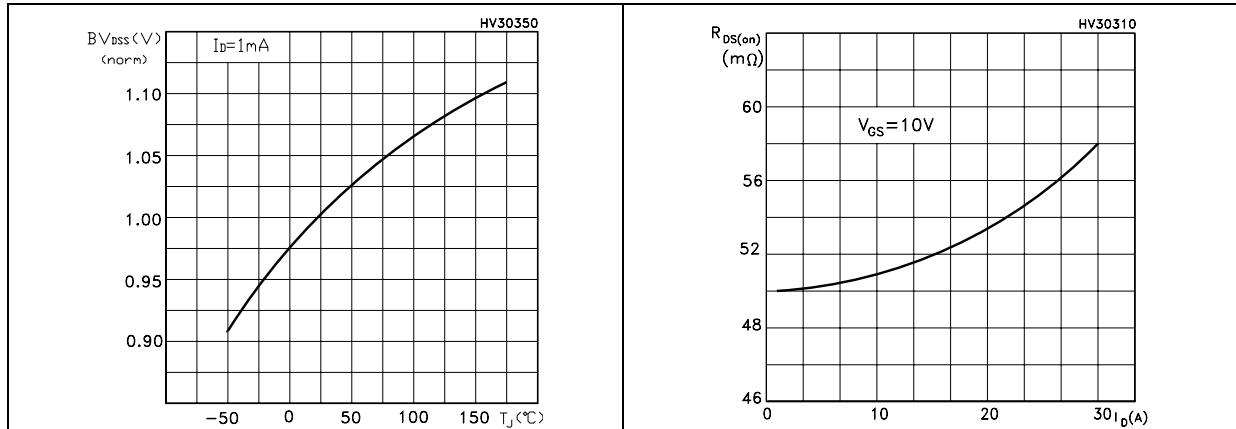

Figure 10. Gate charge vs gate-source voltage

Figure 11. Capacitance variations

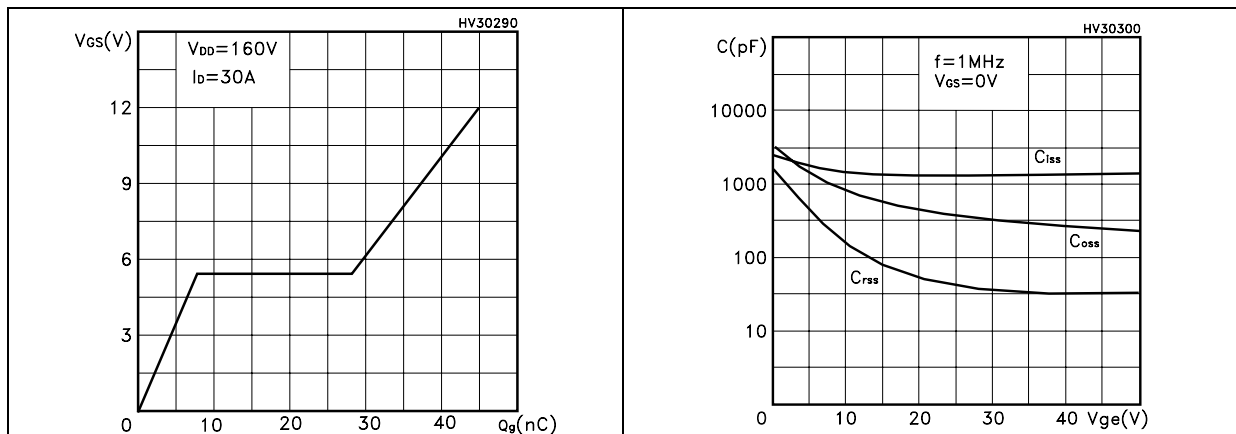

Figure 12. Normalized gate threshold voltage vs temperature

Figure 13. Normalized on resistance vs temperature

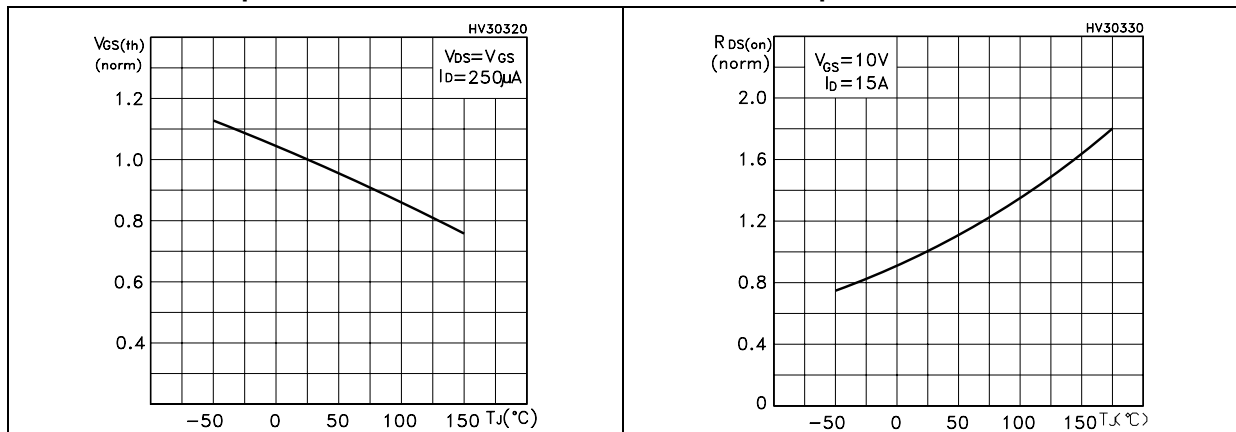

Figure 14. Source-drain diode forward characteristics

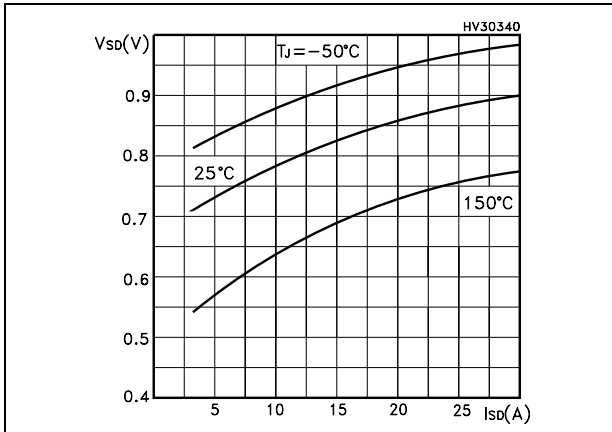
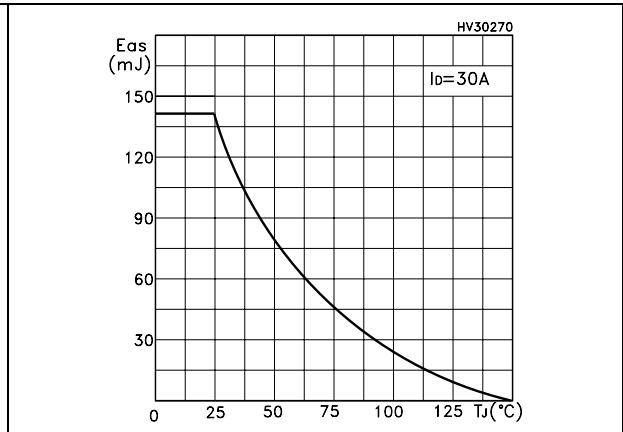

Figure 15. Maximum avalanche energy vs temperature



3 Test circuit

Figure 16. Switching times test circuit for resistive load

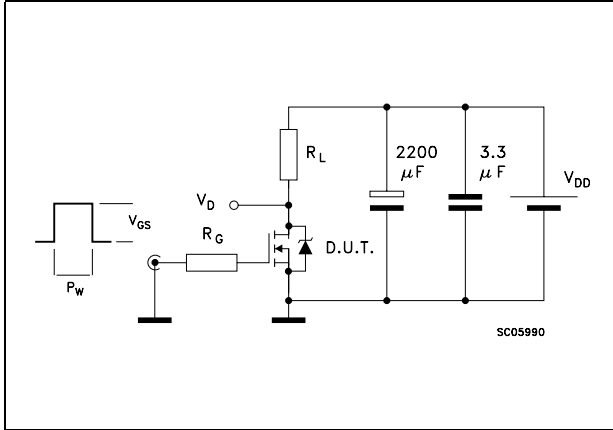

Figure 17. Gate charge test circuit

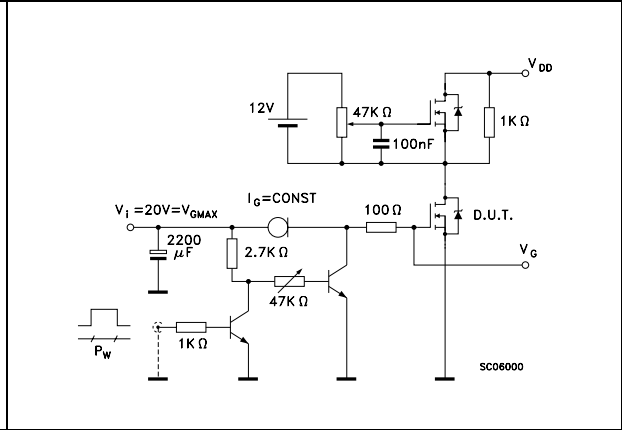

Figure 18. Test circuit for inductive load switching and diode recovery times

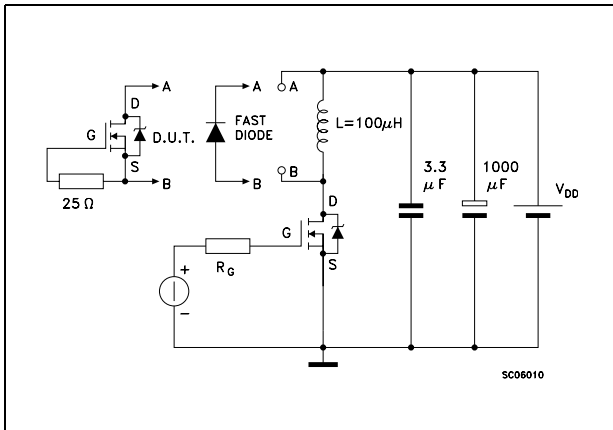

Figure 19. Unclamped inductive load test circuit

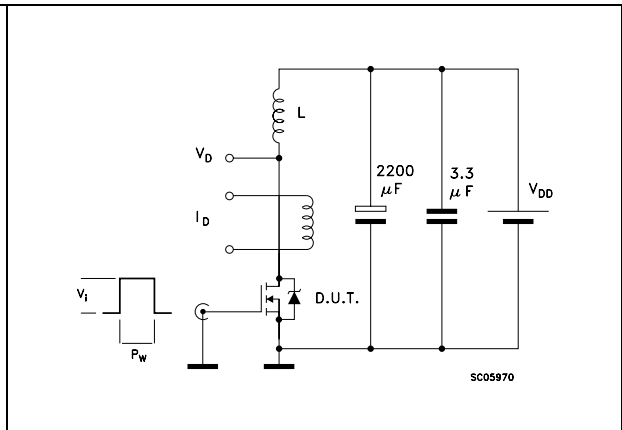

Figure 20. Unclamped inductive waveform

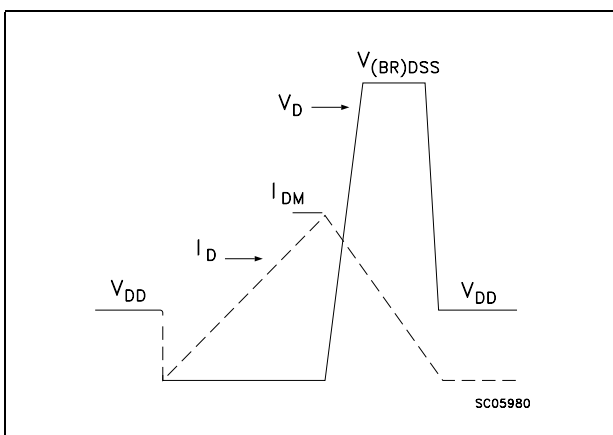
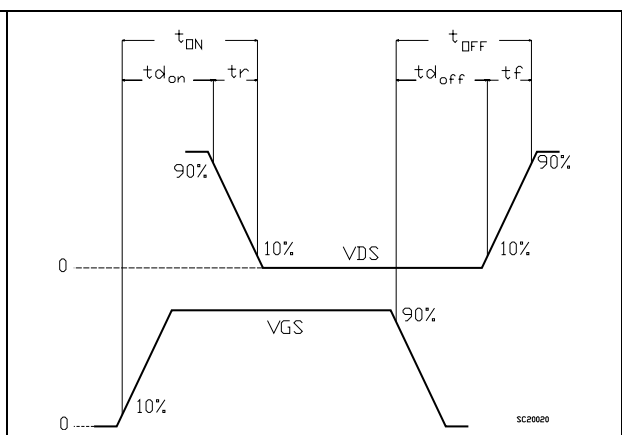

Figure 21. Switching time waveform



4 Package mechanical data

In order to meet environmental requirements, ST offers these devices in ECOPACK® packages. These packages have a Lead-free second level interconnect . The category of second level interconnect is marked on the package and on the inner box label, in compliance with JEDEC Standard JESD97. The maximum ratings related to soldering conditions are also marked on the inner box label. ECOPACK is an ST trademark. ECOPACK specifications are available at: www.st.com

TO-247 MECHANICAL DATA

DIM.	mm.			inch		
	MIN.	TYP.	MAX.	MIN.	TYP.	MAX.
A	4.85		5.15	0.19		0.20
A1	2.20		2.60	0.086		0.102
b	1.0		1.40	0.039		0.055
b1	2.0		2.40	0.079		0.094
b2	3.0		3.40	0.118		0.134
c	0.40		0.80	0.015		0.03
D	19.85		20.15	0.781		0.793
E	15.45		15.75	0.608		0.620
e		5.45			0.214	
L	14.20		14.80	0.560		0.582
L1	3.70		4.30	0.14		0.17
L2		18.50			0.728	
øP	3.55		3.65	0.140		0.143
øR	4.50		5.50	0.177		0.216
S		5.50			0.216	

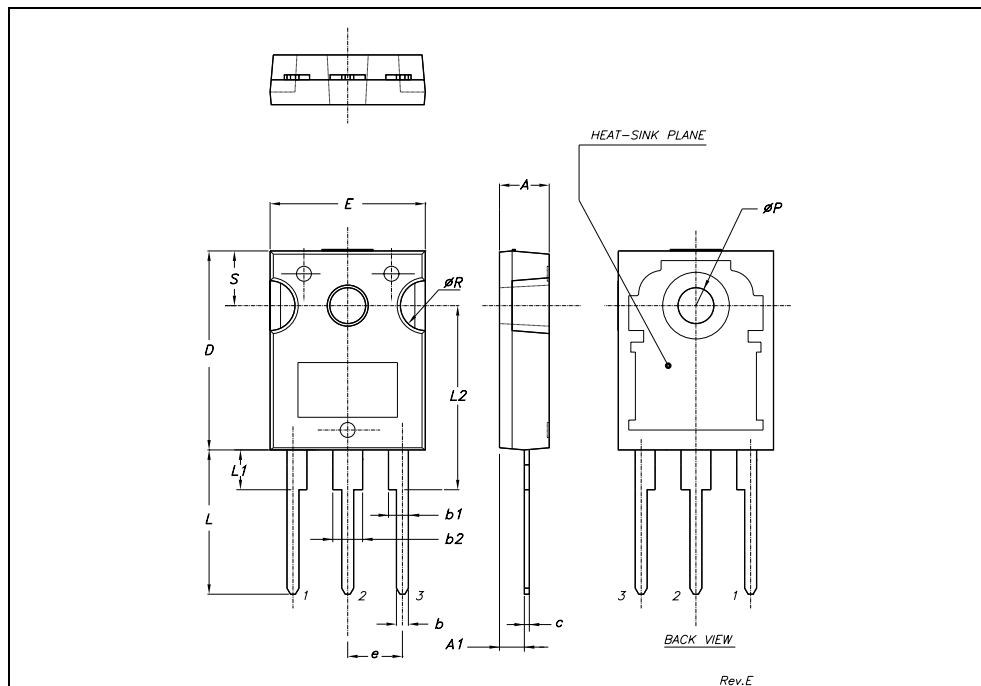

TO-220 MECHANICAL DATA						
DIM.	mm.			inch		
	MIN.	TYP.	MAX.	MIN.	TYP.	MAX.
A	4.40		4.60	0.173		0.181
b	0.61		0.88	0.024		0.034
b1	1.15		1.70	0.045		0.066
c	0.49		0.70	0.019		0.027
D	15.25		15.75	0.60		0.620
E	10		10.40	0.393		0.409
e	2.40		2.70	0.094		0.106
e1	4.95		5.15	0.194		0.202
F	1.23		1.32	0.048		0.052
H1	6.20		6.60	0.244		0.256
J1	2.40		2.72	0.094		0.107
L	13		14	0.511		0.551
L1	3.50		3.93	0.137		0.154
L20		16.40			0.645	
L30		28.90			1.137	
øP	3.75		3.85	0.147		0.151
Q	2.65		2.95	0.104		0.116

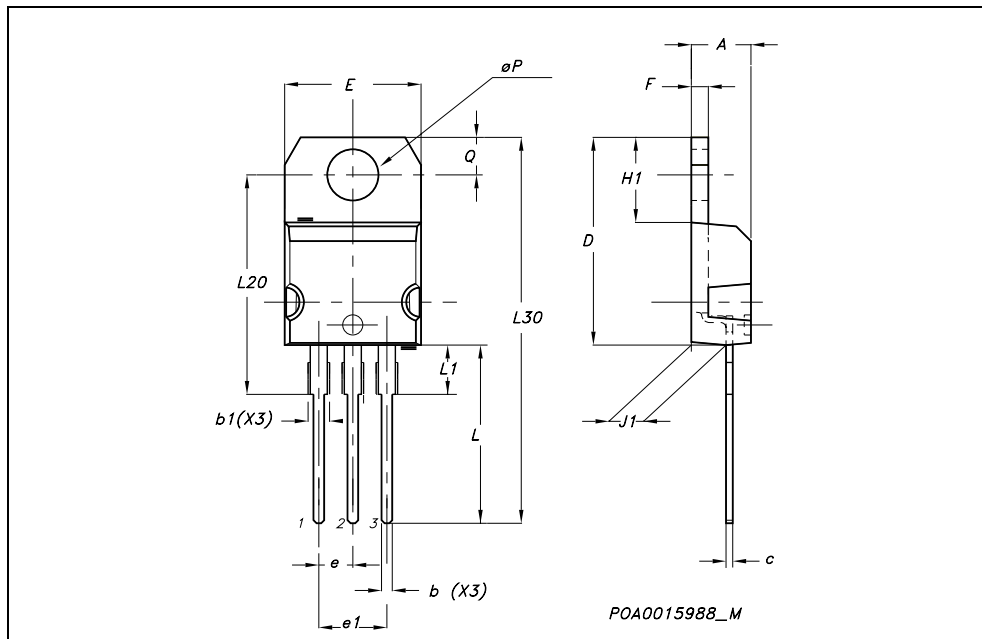

D²PAK mechanical data

Dim	mm			inch		
	Min	Typ	Max	Min	Typ	Max
A	4.4		4.6	0.173		0.181
A1	2.49		2.69	0.098		0.106
A2	0.03		0.23	0.001		0.009
B	0.7		0.93	0.027		0.036
B2	1.14		1.7	0.044		0.067
C	0.45		0.6	0.017		0.023
C2	1.23		1.36	0.048		0.053
D	8.95		9.35	0.352		0.368
D1		8			0.315	
E	10		10.4	0.393		0.409
E1		8.5			0.334	
G	4.88		5.28	0.192		0.208
L	15		15.85	0.590		0.625
L2	1.27		1.4	0.50		0.55
L3	1.4		1.75	0.055		0.68
M	2.4		3.2	0.094		0.126
R		0.4			0.015	
V2	0°		4°			

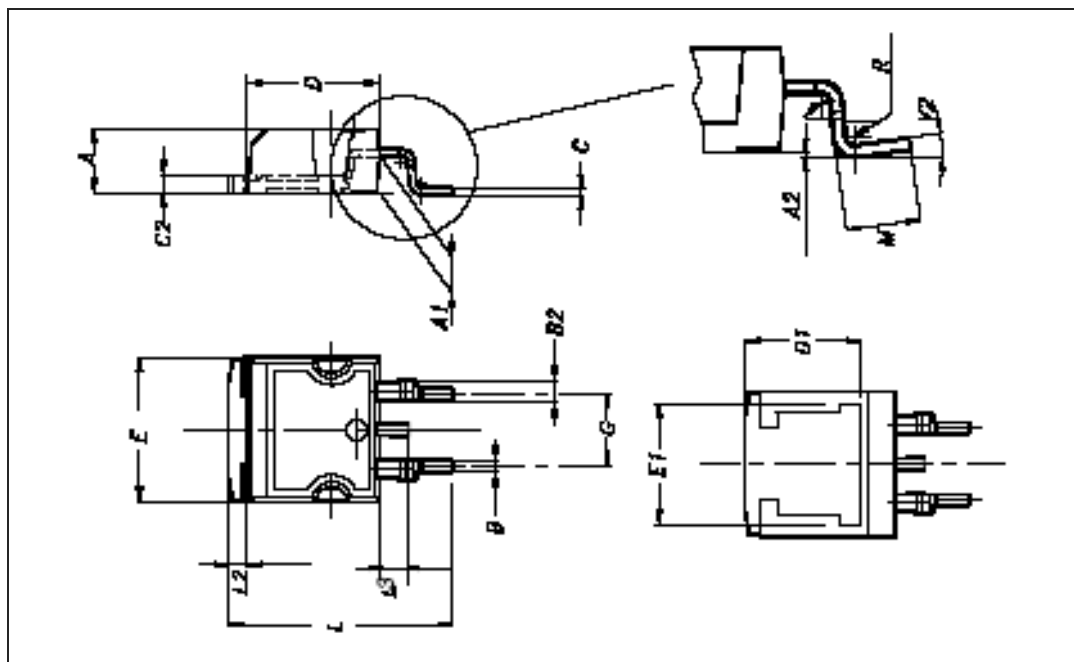

5 Packaging mechanical data

D²PAK FOOTPRINT

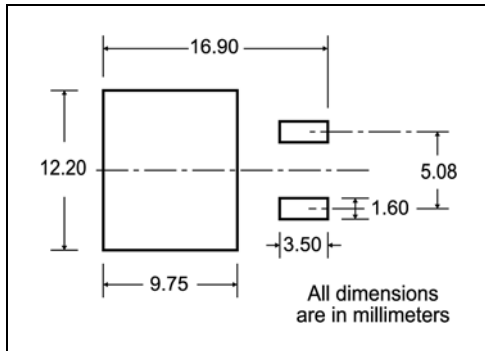

TAPE AND REEL SHIPMENT

40 mm min. Access hole at slot location

Tape slot in core for tape start 2.5mm min. width

Full radius

G measured at hub

REEL MECHANICAL DATA

DIM.	mm		inch	
	MIN.	MAX.	MIN.	MAX.
A		330		12.992
B	1.5		0.059	
C	12.8	13.2	0.504	0.520
D	20.2		0.795	
G	24.4	26.4	0.960	1.039
N	100		3.937	
T		30.4		1.197

BASE QTY	BULK QTY
1000	1000

TAPE MECHANICAL DATA

DIM.	mm		inch	
	MIN.	MAX.	MIN.	MAX.
A0	10.5	10.7	0.413	0.421
B0	15.7	15.9	0.618	0.626
D	1.5	1.6	0.059	0.063
D1	1.59	1.61	0.062	0.063
E	1.65	1.85	0.065	0.073
F	11.4	11.6	0.449	0.456
K0	4.8	5.0	0.189	0.197
P0	3.9	4.1	0.153	0.161
P1	11.9	12.1	0.468	0.476
P2	1.9	2.1	0.075	0.082
R	50		1.574	
T	0.25	0.35	0.0098	0.0137
W	23.7	24.3	0.933	0.956

10 pitches cumulative tolerance on tape +/- 0.2 mm

Center line of cavity

TRL

FEED DIRECTION

Bending radius R min.

* on sales type

6 Revision history

Table 9. Document revision history

Date	Revision	Changes
25-Jan-2007	1	First Release
18-Oct-2007	2	Added D ² PAK

Please Read Carefully:

Information in this document is provided solely in connection with ST products. STMicroelectronics NV and its subsidiaries ("ST") reserve the right to make changes, corrections, modifications or improvements, to this document, and the products and services described herein at any time, without notice.

All ST products are sold pursuant to ST's terms and conditions of sale.

Purchasers are solely responsible for the choice, selection and use of the ST products and services described herein, and ST assumes no liability whatsoever relating to the choice, selection or use of the ST products and services described herein.

No license, express or implied, by estoppel or otherwise, to any intellectual property rights is granted under this document. If any part of this document refers to any third party products or services it shall not be deemed a license grant by ST for the use of such third party products or services, or any intellectual property contained therein or considered as a warranty covering the use in any manner whatsoever of such third party products or services or any intellectual property contained therein.

UNLESS OTHERWISE SET FORTH IN ST'S TERMS AND CONDITIONS OF SALE ST DISCLAIMS ANY EXPRESS OR IMPLIED WARRANTY WITH RESPECT TO THE USE AND/OR SALE OF ST PRODUCTS INCLUDING WITHOUT LIMITATION IMPLIED WARRANTIES OF MERCHANTABILITY, FITNESS FOR A PARTICULAR PURPOSE (AND THEIR EQUIVALENTS UNDER THE LAWS OF ANY JURISDICTION), OR INFRINGEMENT OF ANY PATENT, COPYRIGHT OR OTHER INTELLECTUAL PROPERTY RIGHT.

UNLESS EXPRESSLY APPROVED IN WRITING BY AN AUTHORIZED ST REPRESENTATIVE, ST PRODUCTS ARE NOT RECOMMENDED, AUTHORIZED OR WARRANTED FOR USE IN MILITARY, AIR CRAFT, SPACE, LIFE SAVING, OR LIFE SUSTAINING APPLICATIONS, NOR IN PRODUCTS OR SYSTEMS WHERE FAILURE OR MALFUNCTION MAY RESULT IN PERSONAL INJURY, DEATH, OR SEVERE PROPERTY OR ENVIRONMENTAL DAMAGE. ST PRODUCTS WHICH ARE NOT SPECIFIED AS "AUTOMOTIVE GRADE" MAY ONLY BE USED IN AUTOMOTIVE APPLICATIONS AT USER'S OWN RISK.

Resale of ST products with provisions different from the statements and/or technical features set forth in this document shall immediately void any warranty granted by ST for the ST product or service described herein and shall not create or extend in any manner whatsoever, any liability of ST.

ST and the ST logo are trademarks or registered trademarks of ST in various countries.

Information in this document supersedes and replaces all information previously supplied.

The ST logo is a registered trademark of STMicroelectronics. All other names are the property of their respective owners.

© 2007 STMicroelectronics - All rights reserved

STMicroelectronics group of companies

Australia - Belgium - Brazil - Canada - China - Czech Republic - Finland - France - Germany - Hong Kong - India - Israel - Italy - Japan - Malaysia - Malta - Morocco - Singapore - Spain - Sweden - Switzerland - United Kingdom - United States of America

www.st.com