



## 16-Bit, 10 MSPS ANALOG-TO-DIGITAL CONVERTER

### FEATURES

- High-Speed, Wide Bandwidth  $\Delta\Sigma$  ADC
- 10MSPS Output Data Rate
- 4.9MHz Signal Bandwidth
- 86dBFS Signal-to-Noise Ratio
- –94dB Total Harmonic Distortion
- 95dB Spurious-Free Dynamic Range
- On-Chip Digital Filter Simplifies Anti-Alias Requirements
- SYNC Pin for Simultaneous Sampling with Multiple ADS1610s
- Low 3 $\mu$ s Group Delay
- Parallel Interface
- Directly Connects to TMS320 DSPs
- Out-of-Range Alert Pin

### APPLICATIONS

- Scientific Instruments
- Test Equipment
- Communications

### DESCRIPTION

The ADS1610 is a high-speed, high-precision, delta-sigma ( $\Delta\Sigma$ ) analog-to-digital converter (ADC) with 16-bit resolution operating from a 5V analog and a 3V digital supply. Featuring an advanced multi-stage analog modulator combined with an on-chip digital decimation filter, the ADS1610 achieves 86 dBFS signal-to-noise ratio (SNR) in a 5MHz signal bandwidth; while the total harmonic distortion is -94dB.

The ADS1610  $\Delta\Sigma$  topology provides key system-level design advantages with respect to anti-alias filtering and clock jitter. The design of the user's front-end anti-alias filter is simplified since the on-chip digital filter greatly attenuates out-of-band signals. The ADS1610s filter has a *brick wall* response with a very flat passband ( $\pm 0.0002$ dB of ripple) followed immediately by a very wide stop band (5MHz to 55MHz). Clock jitter becomes especially critical when digitizing high frequency, large-amplitude signals. The ADS1610 significantly reduces clock jitter sensitivity by an effective averaging of clock jitter as a result of oversampling the input signal.

Output data is supplied over a parallel interface and easily connects to TMS320 digital signal processors (DSPs). The power dissipation can be adjusted with an external resistor, allowing for reduction at lower operating speeds.

With its outstanding high-speed performance, the ADS1610 is well-suited for demanding applications in data acquisition, scientific instruments, test and measurement equipment, and communications. The ADS1610 is offered in a TQFP64 package and is specified from –40°C to 85°C.

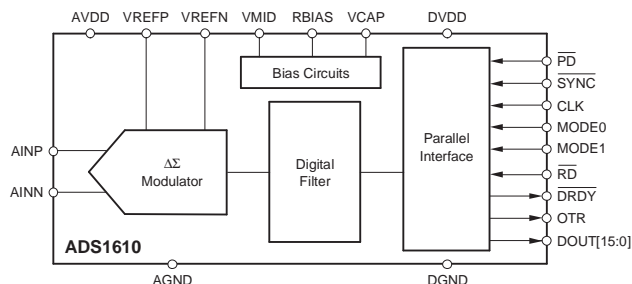

Please be aware that an important notice concerning availability, standard warranty, and use in critical applications of Texas Instruments semiconductor products and disclaimers thereto appears at the end of this data sheet.

PowerPAD is a trademark of Texas Instruments.



This integrated circuit can be damaged by ESD. Texas Instruments recommends that all integrated circuits be handled with appropriate precautions. Failure to observe proper handling and installation procedures can cause damage. ADS1610 passes 1.5K CDM testing. ADS1610 passes 1kV human body model testing (TI Standard is 2kV).

ESD damage can range from subtle performance degradation to complete device failure. Precision integrated circuits may be more susceptible to damage because very small parametric changes could cause the device not to meet its published specifications.

## PACKAGE/ORDERING INFORMATION

For the most current package and ordering information, see the Package Option Addendum at the end of this document, or see the TI website at [www.ti.com](http://www.ti.com).

## ABSOLUTE MAXIMUM RATINGS

over operating free-air temperature range (unless otherwise noted) <sup>(1)</sup>

	VALUE	UNIT
AVDD to AGND	-0.3 to +6	V
DVDD to DGND	-0.3 to +3.6	V
AGND to DGND	-0.3 to +0.3	V
Input current, I <sub>I</sub>	100, Momentary	mA
	10, Continuous	
Analog I/O to AGND	-0.3 to AVDD + 0.3	V
Digital I/O to DGND	-0.3 to DVDD + 0.3	V
Maximum junction temperature, T <sub>J</sub>	150	°C
Operating free-air temperature range, T <sub>A</sub>	-40 to +105	°C
Storage temperature range, T <sub>stg</sub>	-60 to +150	°C
Lead temperature (soldering, 10s)	260	°C

(1) Stresses above these ratings may cause permanent damage. Exposure to absolute maximum conditions for extended periods may degrade device reliability. These are stress ratings only, and functional operation of the device at these or any other conditions beyond those specified is not implied.

## ELECTRICAL CHARACTERISTICS

All specifications at -40°C to 85°C, AVDD = 5V, DVDD = 3V, f<sub>CLK</sub> = 60MHz, V<sub>REF</sub> = 3V, MODE = 00, V<sub>CM</sub> = 2.5V, and R<sub>BIAS</sub> = 19kΩ (unless otherwise noted).

PARAMETER		TEST CONDITIONS	MIN	TYP	MAX	UNIT
<b>ANALOG INPUT</b>						
V <sub>ID(AINP - AINN)</sub>	Differential input voltage (AINP-AINN)			±V <sub>REF</sub>		V
V <sub>IC(AINP + AINN)/2</sub>	Common-mode input voltage			2.5		V
V <sub>IHA</sub>	Absolute input voltage (AINP or AINN with respect to AGND)		-0.1		4.2	V
<b>DYNAMIC SPECIFICATIONS</b>						
	Data rate			$10 \left( \frac{f_{CLK}}{60 \text{ MHz}} \right)$		MSPS
SNR	Signal-to-noise ration relative to full-scale <sup>(1)</sup>	f <sub>IN</sub> = 100kHz, -2dBFS	83	86		dBFS

(1) For reference, this dynamic specification is extrapolated to full-scale and is thus dBFS. Subsequent dynamic specifications are dBc (dB), which is: Specification (in dBc) = Specification (in dBFS) + AIN (input amplitude in dBFS). For more information see [Understanding and comparing datasheets for high-speed ADCs](#).

### ELECTRICAL CHARACTERISTICS (continued)

All specifications at  $-40^{\circ}\text{C}$  to  $85^{\circ}\text{C}$ ,  $\text{AVDD} = 5\text{V}$ ,  $\text{DVDD} = 3\text{V}$ ,  $f_{\text{CLK}} = 60\text{MHz}$ ,  $V_{\text{REF}} = 3\text{V}$ ,  $\text{MODE} = 00$ ,  $V_{\text{CM}} = 2.5\text{V}$ , and  $\text{RBIAS} = 19\text{k}\Omega$  (unless otherwise noted).

PARAMETER		TEST CONDITIONS	MIN	TYP	MAX	UNIT
SNR	Signal-to-noise ratio	$f_{\text{IN}} = 100\text{kHz}, -2\text{dBFS}$	81	84		dB
		$f_{\text{IN}} = 100\text{kHz}, -6\text{dBFS}$	77	80		
		$f_{\text{IN}} = 100\text{kHz}, -20\text{dBFS}$		66		
		$f_{\text{IN}} = 1\text{MHz}, -2\text{dBFS}$		83		
		$f_{\text{IN}} = 1\text{MHz}, -6\text{dBFS}$		80		
		$f_{\text{IN}} = 1\text{MHz}, -20\text{dBFS}$		66		
		$f_{\text{IN}} = 4\text{MHz}, -2\text{dBFS}$	79.5	83		
		$f_{\text{IN}} = 4\text{MHz}, -6\text{dBFS}$	76	79		
		$f_{\text{IN}} = 4\text{MHz}, -20\text{dBFS}$		65		
THD	Total harmonic distortion	$f_{\text{IN}} = 100\text{kHz}, -2\text{dBFS}$		-90	-83	dB
		$f_{\text{IN}} = 100\text{kHz}, -6\text{dBFS}$		-95	-85	
		$f_{\text{IN}} = 100\text{kHz}, -20\text{dBFS}$		-95		
		$f_{\text{IN}} = 1\text{MHz}, -2\text{dBFS}$		-91		
		$f_{\text{IN}} = 1\text{MHz}, -6\text{dBFS}$		-93		
		$f_{\text{IN}} = 1\text{MHz}, -20\text{dBFS}$		-95		
		$f_{\text{IN}} = 4\text{MHz}, -2\text{dBFS}$		-109	-100	
		$f_{\text{IN}} = 4\text{MHz}, -6\text{dBFS}$		-105	-100	
		$f_{\text{IN}} = 4\text{MHz}, -20\text{dBFS}$		-95		
SINAD	Signal-to-noise and distortion	$f_{\text{IN}} = 100\text{kHz}, -2\text{dBFS}$		83		dB
		$f_{\text{IN}} = 100\text{kHz}, -6\text{dBFS}$		79		
		$f_{\text{IN}} = 100\text{kHz}, -20\text{dBFS}$		65		
		$f_{\text{IN}} = 1\text{MHz}, -2\text{dBFS}$		82		
		$f_{\text{IN}} = 1\text{MHz}, -6\text{dBFS}$		79		
		$f_{\text{IN}} = 1\text{MHz}, -20\text{dBFS}$		65		
		$f_{\text{IN}} = 4\text{MHz}, -2\text{dBFS}$		83		
		$f_{\text{IN}} = 4\text{MHz}, -6\text{dBFS}$		79		
		$f_{\text{IN}} = 4\text{MHz}, -20\text{dBFS}$		65		
SFDR	Spurious-free dynamic range	$f_{\text{IN}} = 100\text{kHz}, -2\text{dBFS}$	85	90		dB
		$f_{\text{IN}} = 100\text{kHz}, -6\text{dBFS}$	90	96		
		$f_{\text{IN}} = 100\text{kHz}, -20\text{dBFS}$		96		
		$f_{\text{IN}} = 1\text{MHz}, -2\text{dBFS}$		94		
		$f_{\text{IN}} = 1\text{MHz}, -6\text{dBFS}$		94		
		$f_{\text{IN}} = 1\text{MHz}, -20\text{dBFS}$		96		
		$f_{\text{IN}} = 4\text{MHz}, -2\text{dBFS}$	100	109		
		$f_{\text{IN}} = 4\text{MHz}, -6\text{dBFS}$	100	105		
		$f_{\text{IN}} = 4\text{MHz}, -20\text{dBFS}$		95		
	Aperture jitter	Excludes jitter of CLK source		2		ps, rms
	Aperture delay			4		ns

**ELECTRICAL CHARACTERISTICS (Continued)**

All specifications at –40°C to 85°C, AVDD = 5V, DVDD = 3V, f<sub>CLK</sub> = 60MHz, V<sub>REF</sub> = 3V, MODE = 00, V<sub>CM</sub> = 2.5V, and R<sub>BIAS</sub> = 19kΩ (unless otherwise noted).

PARAMETER	TEST CONDITIONS	MIN	TYP	MAX	UNIT
<b>DIGITAL FILTER CHARACTERISTICS</b>					
Passband		0		$4.4 \left( \frac{f_{CLK}}{60 \text{ MHz}} \right)$	MHz
Passband ripple				±0.0002	dB
Passband transition	–0.1dB attenuation		$4.6 \left( \frac{f_{CLK}}{60 \text{ MHz}} \right)$		MHz
	–3.0dB attenuation		$4.9 \left( \frac{f_{CLK}}{60 \text{ MHz}} \right)$		
Stop band		5.6		54.4	MHz
Stop band attenuation		80	See Figure 34		dB
t <sub>d(grp)</sub> Group delay			$3.0 \left( \frac{60 \text{ MHz}}{f_{CLK}} \right)$		μs
t <sub>s</sub> Settling time	To ±0.001%		$5.5 \left( \frac{60 \text{ MHz}}{f_{CLK}} \right)$		μs
<b>STATIC SPECIFICATIONS</b>					
Resolution	No missing codes	16			Bits
Input rms noise	Shorted input		1.0	1.4	LSB (rms)
Integral nonlinearity	1V input		±0.4		LSB
	2.5V input		±1.5		LSB
Differential nonlinearity			±0.5		LSB
V <sub>IO</sub> Offset error	T = 25°C		0.05		%FS
Offset drift			5		ppm/°C
G <sub>(ERR)</sub> Gain error	T = 25°C		±0.3 <sup>(1)</sup>		%FS
G Gain drift	Excluding reference drift		10		ppm/°C
CMRR Common-mode rejection ratio	At DC		60		dB
PSRR Supply-voltage rejection ratio	At DC		80		dB
<b>VOLTAGE REFERENCE</b>					
V <sub>ref</sub> Reference voltage, (VREFP - VREFN)		2.9	3.0	3.1	V
VREFP		3.6	4.0	4.4	V
VREFN		0.9	1.0	1.1	V
VMID		2.2	2.5	3.8	V
<b>DIGITAL INPUT/OUTPUT</b>					
V <sub>IH</sub> High-level input voltage		0.7DVDD		DVDD	V
V <sub>IL</sub> Low-level input voltage		DGND		0.3DVDD	V
V <sub>OH</sub> High-level output voltage	I <sub>OH</sub> = –50μA	0.8DVDD			V
V <sub>OL</sub> Low-level output voltage	I <sub>OL</sub> = 50μA			0.2DVDD	V
I <sub>ikg</sub> Input leakage current	DGND < V <sub>DIGITAL INPUT</sub> < DVDD			±10	μA
<b>POWER-SUPPLY REQUIREMENTS</b>					
V <sub>AVDD</sub> AVDD voltage		4.9	5.0	5.1	V
V <sub>DVDD</sub> DVDD voltage		2.7	3.0	3.6	V
I <sub>AVDD</sub> AVDD current			150	170	mA
I <sub>DVDD</sub> DVDD current			70	80	mA
P <sub>D</sub> Power dissipation			960	1100	mW
	PD = low		4		

(1) There is a constant gain error of 3.8% in addition to the variable gain error of ±0.3%. Therefore, the gain error is 3.8 ±0.3%.

## DEVICE INFORMATION

### PIN CONFIGURATION

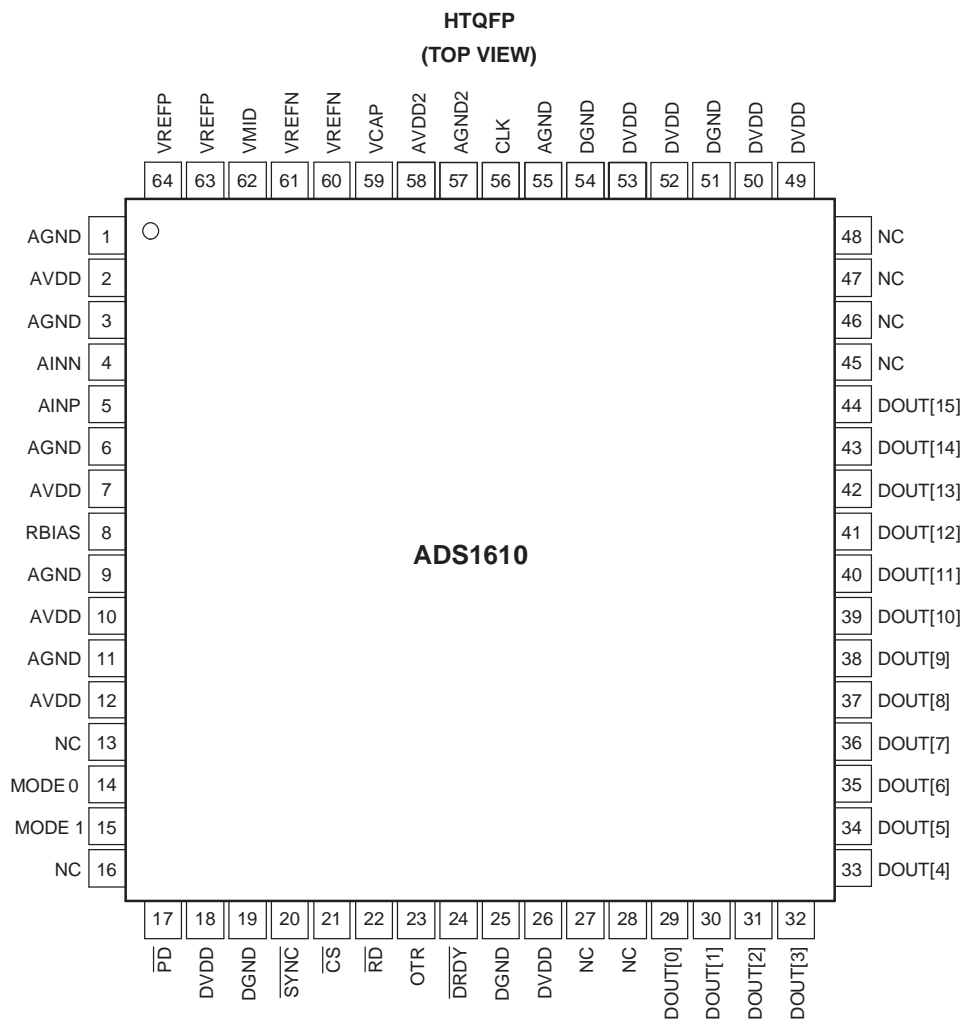

### TERMINAL FUNCTIONS

TERMINAL		ANALOG/DIGITAL INPUT/OUTPUT	DESCRIPTION
NAME	NO.		
AGND	1, 3, 6, 9, 11, 55	Analog	Analog ground
AVDD	2, 7, 10, 12	Analog	Analog supply
AINN	4	Analog input	Negative analog input
AINP	5	Analog input	Positive analog input
RBIAS	8	Analog	Analog bias setting resistor
NC	13, 16, 27, 28, 45–48	—	Must be left unconnected.
MODE	14, 15	Digital input	Control for four output modes (See <i>MODE SELECTION</i> section)
$\overline{\text{PD}}$	17	Digital input; active low	Power-down
DVDD	18, 26, 49, 50, 52, 53	Digital	Digital supply
DGND	19, 25, 51, 54	Digital	Digital ground
$\overline{\text{SYNC}}$	20	Digital input; active low	Digital reset
$\overline{\text{CS}}$	21	Digital input; active low	Chip-select

**TERMINAL FUNCTIONS (continued)**

TERMINAL		ANALOG/DIGITAL INPUT/OUTPUT	DESCRIPTION
NAME	NO.		
$\overline{\text{RD}}$	22	Digital input; Active low	Read enable
OTR	23	Digital output	Analog inputs out-of-range
$\overline{\text{DRDY}}$	24	Digital output	Data ready
DOUT[15:0]	29–44	Digital output	Data output. DOUT[15] is the MSB and DOUT[0] is the LSB.
CLK	56	Digital input	Clock input
AGND2	57	Analog	Analog ground for AVDD2
AVDD2	58	Analog	Analog supply for modulator clocking
VCAP	59	Analog	Bypass capacitor
VREFN	60, 61	Analog	Negative reference voltage
VMID	62	Analog	Midpoint voltage
VREFP	63, 64	Analog	Positive reference voltage

**TIMING SPECIFICATIONS**

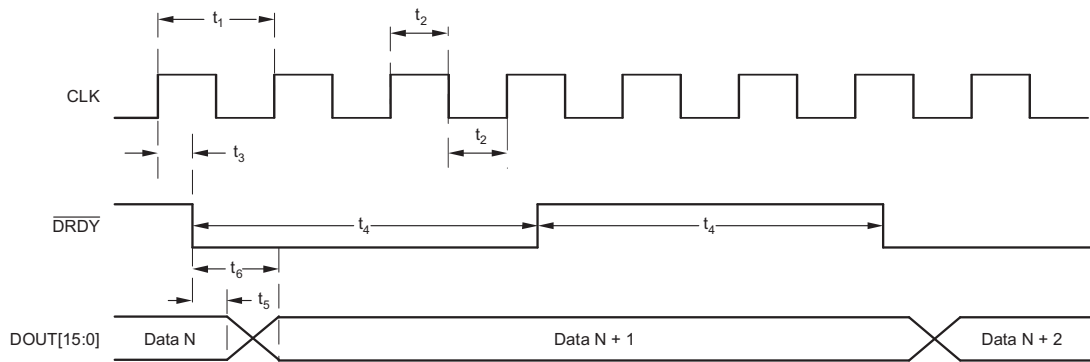

**Figure 1. Data Retrieval Timing**

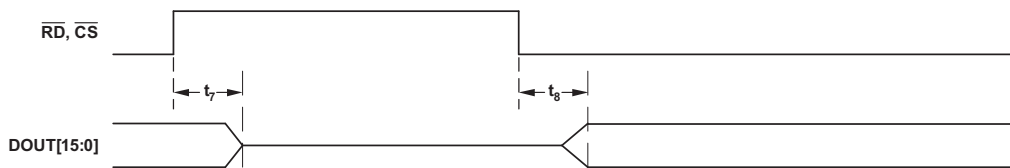

**Figure 2. DOUT Inactive/Active Timing**

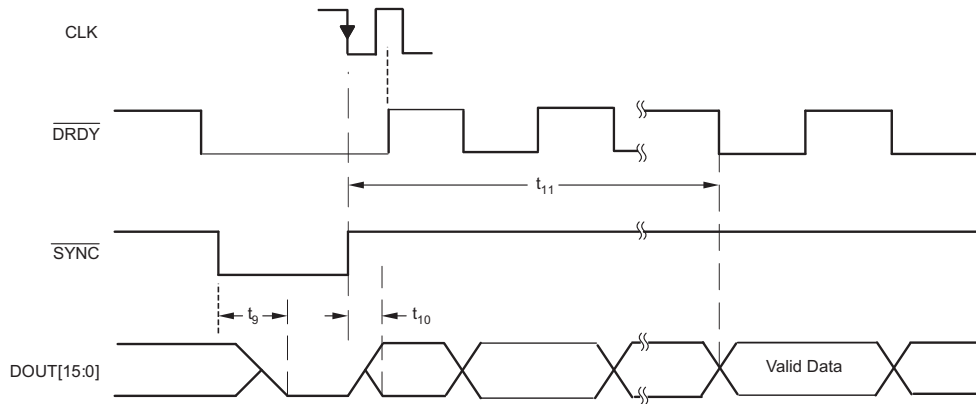

**Figure 3. Reset Timing**

**Timing Specifications<sup>(1)</sup>**

DESCRIPTION		MIN	TYP	MAX	UNIT
$t_1$	CLK period ( $1/f_{CLK}$ )	16.667			ns
$1/t_1$	$f_{CLK}$	1		60	MHz
$t_2$	CLK pulse width, high or low	45%		55%	ns
$t_3$	CLK to $\overline{DRDY}$ high (propagation delay)		12		ns
$t_4$	$\overline{DRDY}$ pulse width, high or low		$3 t_1$		ns
$t_5$	Previous data valid (hold time)	0			ns
$t_6$	New data valid (setup time)			5	ns
$t_7$	$\overline{RD}$ and/or $\overline{CS}$ inactive (high) to DOUT high impedance		15		ns
$t_8$	$\overline{RD}$ and/or $\overline{CS}$ active (low) to DOUT active		15		ns
$t_9$	Delay from $\overline{SYNC}$ active (low) to all-zero DOUT[15:0]		12		ns
$t_{10}$	Delay from $\overline{SYNC}$ inactive (high) to non-zero DOUT[15:0]			21	DRDY
$t_{11}$	Delay from $\overline{SYNC}$ inactive (high) to valid DOUT[15:0] (time – 55 $\overline{DRDY}$ cycles; required for digital filter to settle).		55		DRDY

(1) Output load = 10pF|| 500kΩ.

**TYPICAL CHARACTERISTICS**

At  $T_A = 25^\circ\text{C}$ ,  $R_{BIAS} = 19\text{k}\Omega$ ,  $AVDD = 5\text{V}$ ,  $DVDD = 3\text{V}$ ,  $f_{CLK} = 60\text{MHz}$ ,  $V_{REF} = 3\text{V}$ ,  $\text{MODE} = 00$ , and  $V_{CM} = 2.5\text{V}$  (unless otherwise noted).

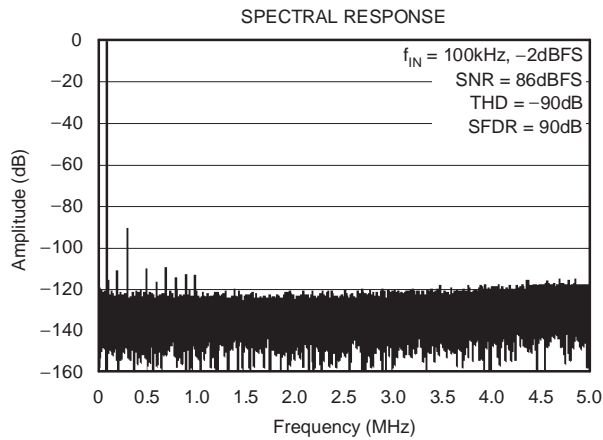

**Figure 4.**

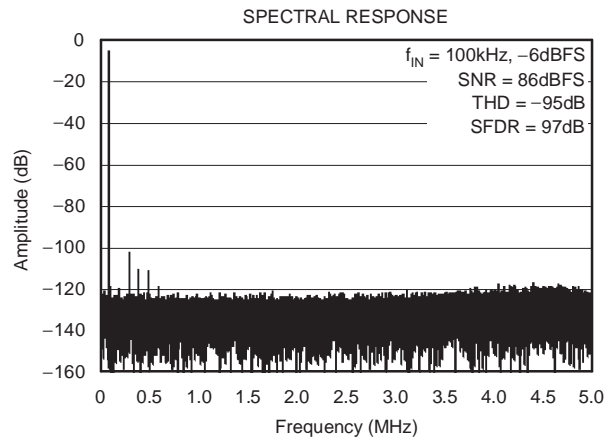

**Figure 5.**

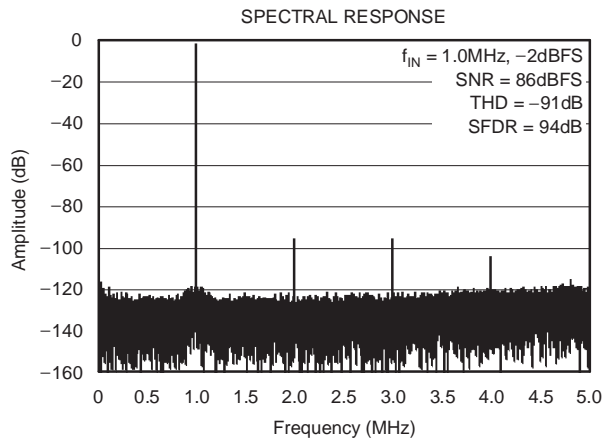

**Figure 6.**

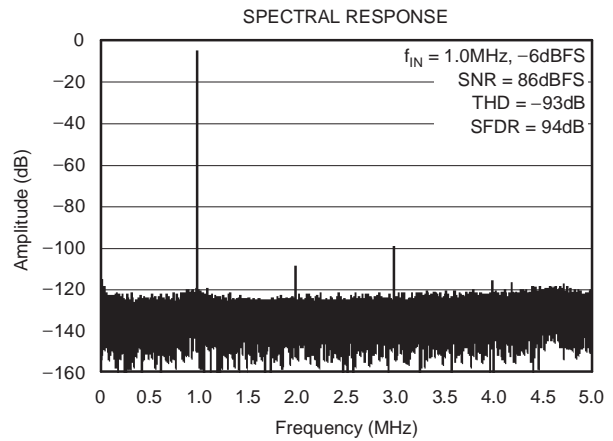

**Figure 7.**

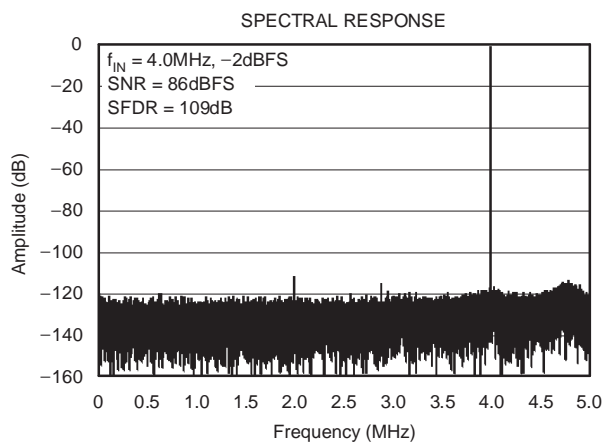

**Figure 8.**

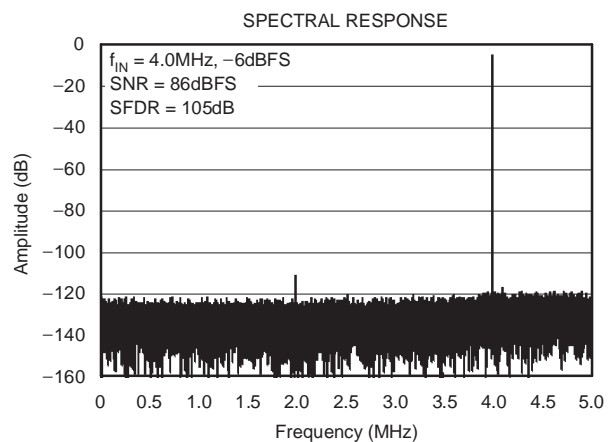

**Figure 9.**



**TYPICAL CHARACTERISTICS (continued)**

At  $T_A = 25^\circ\text{C}$ ,  $R_{BIAS} = 19\text{k}\Omega$ ,  $AV_{DD} = 5\text{V}$ ,  $DV_{DD} = 3\text{V}$ ,  $f_{CLK} = 60\text{MHz}$ ,  $V_{REF} = 3\text{V}$ ,  $MODE = 00$ , and  $V_{CM} = 2.5\text{V}$  (unless otherwise noted).

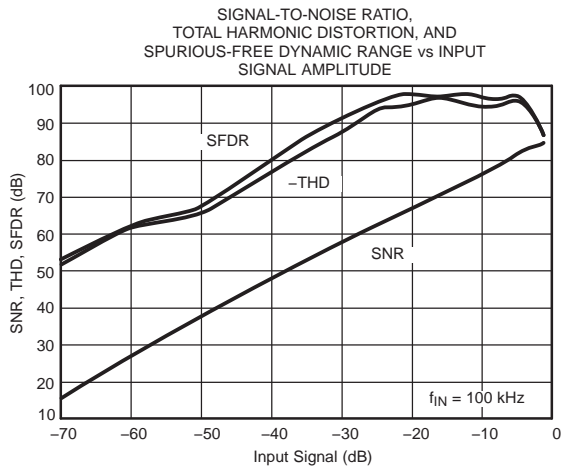

Figure 10.

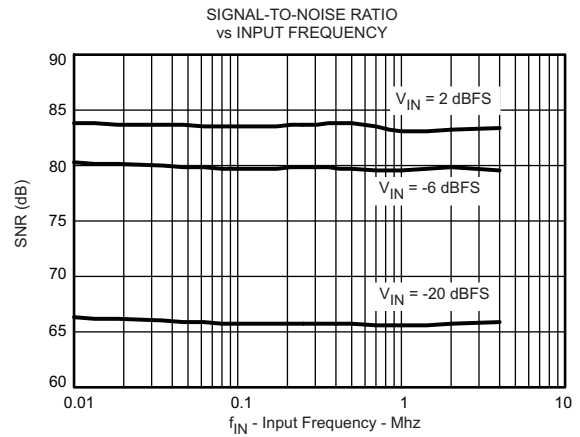

Figure 11.

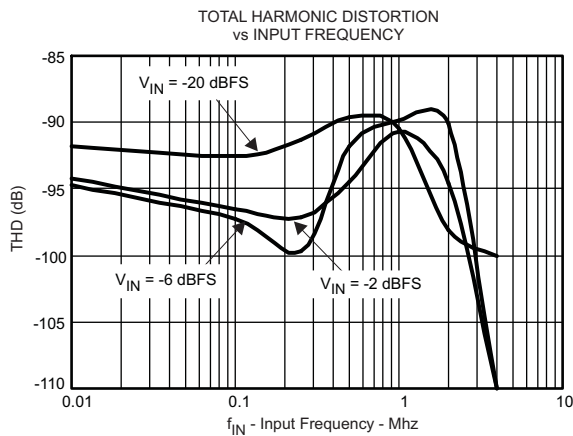

Figure 12.

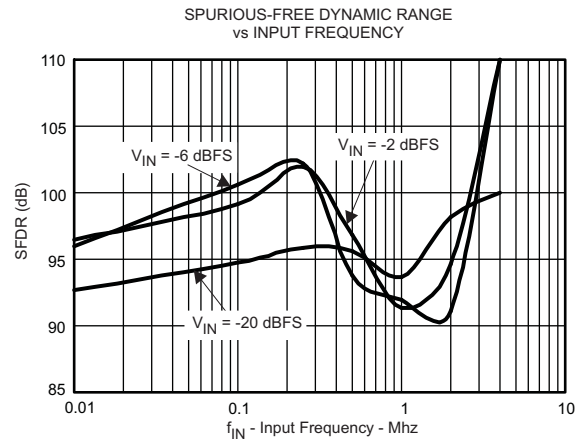

Figure 13.

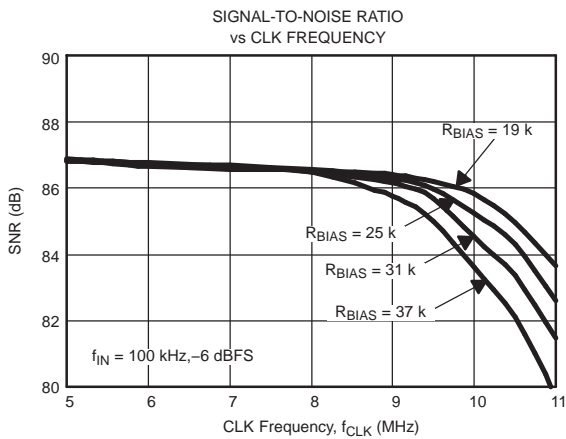

Figure 14.

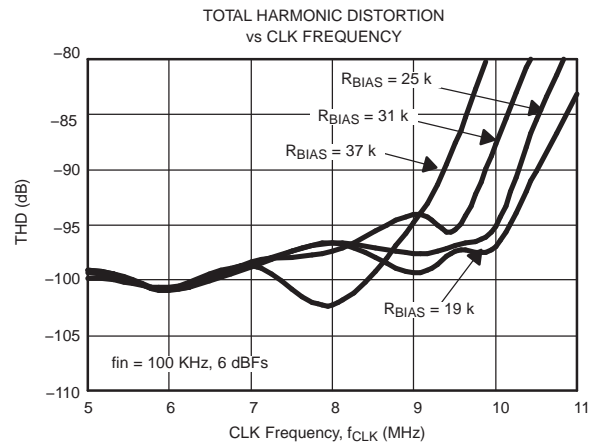
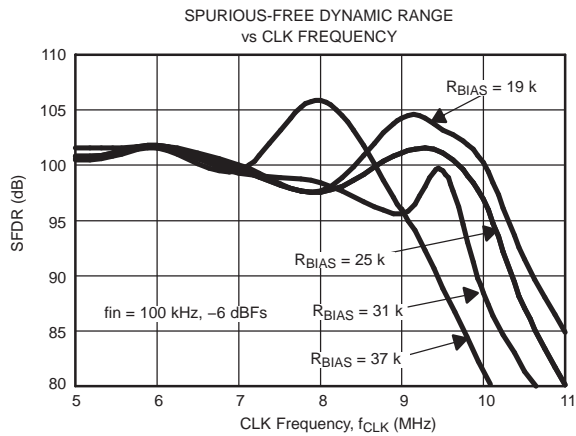

Figure 15.

**TYPICAL CHARACTERISTICS (continued)**

At  $T_A = 25^\circ\text{C}$ ,  $R_{BIAS} = 19\text{k}\Omega$ ,  $AVDD = 5\text{V}$ ,  $DVDD = 3\text{V}$ ,  $f_{CLK} = 60\text{MHz}$ ,  $V_{REF} = 3\text{V}$ ,  $MODE = 00$ , and  $V_{CM} = 2.5\text{V}$  (unless otherwise noted).



**Figure 16.**

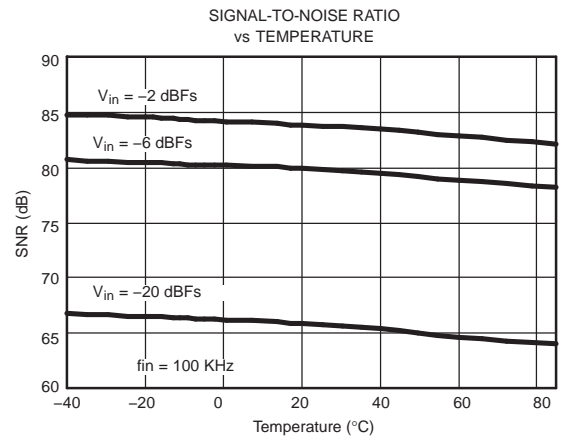

**Figure 17.**

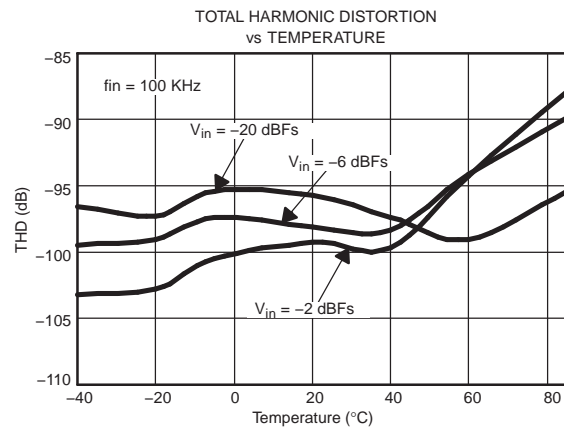

**Figure 18.**

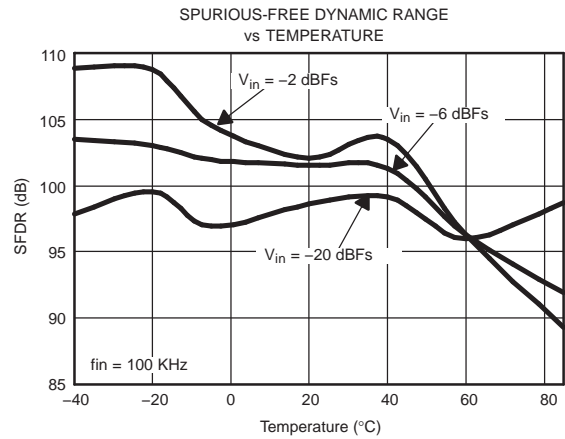

**Figure 19.**

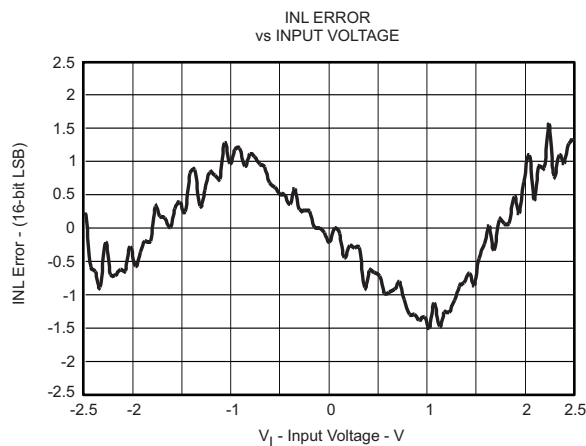

**Figure 20.**

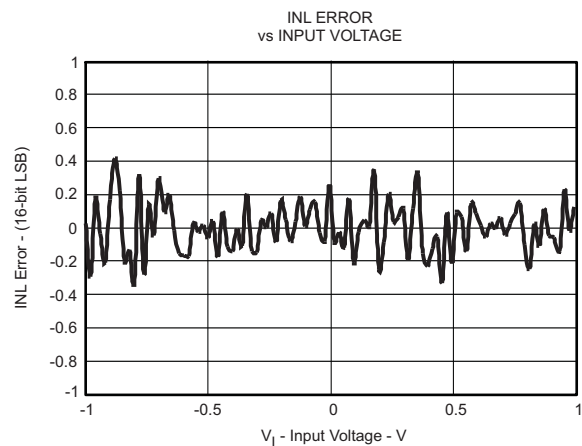

**Figure 21.**

**TYPICAL CHARACTERISTICS (continued)**

At  $T_A = 25^\circ\text{C}$ ,  $R_{BIAS} = 19\text{k}\Omega$ ,  $AVDD = 5\text{V}$ ,  $DVDD = 3\text{V}$ ,  $f_{CLK} = 60\text{MHz}$ ,  $V_{REF} = 3\text{V}$ ,  $\text{MODE} = 00$ , and  $V_{CM} = 2.5\text{V}$  (unless otherwise noted).

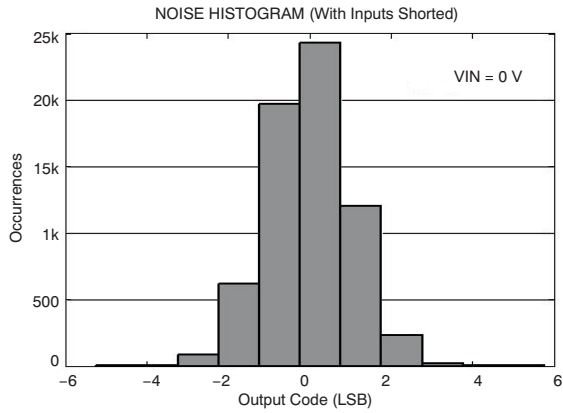

Figure 22.

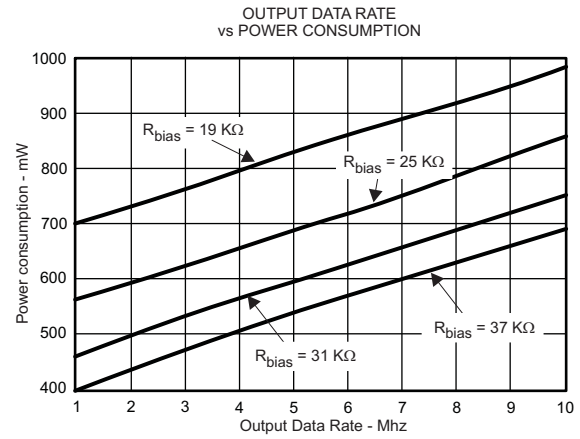

Figure 23.

**OVERVIEW**

The ADS1610 is a high-performance, delta-sigma ADC. The modulator uses an inherently stable, pipelined, delta-sigma modulator architecture incorporating proprietary circuitry that allows for very linear high-speed operation. The modulator samples the input signal at 60MSPS (when  $f_{CLK} = 60\text{MHz}$ ). A low-ripple linear phase digital filter decimates the modulator output by 6 to provide data output word rates of 10MSPS with a signal passband out to 4.9MHz.

Conceptually, the modulator and digital filter measure the differential input signal,  $V_{ID} = (A\text{INP} - A\text{INN})$ , against the differential reference,  $V_{ref} = (V\text{REFP} - V\text{REFN})$ , as shown in Figure 11. A 16-bit parallel data bus, designed for direct connection to DSPs, outputs the data. A separate power supply for the I/O allows flexibility for interfacing to different logic families. Out-of-range conditions are indicated with a dedicated digital output pin. Analog power dissipation is controlled using an external resistor. This allows reduced dissipation when operating at slower speeds. When not in use, power consumption can be dramatically reduced using the PD pin.

**ANALOG INPUTS (AINP, AINN)**

The ADS1610 supports a very wide range of input signals. Having such a wide input range makes out-of-range signals unlikely. However, should an out-of-range signal occur, the digital output OTR will go high.

To achieve the highest analog performance, it is recommended that the inputs be limited to no greater than  $0.891V_{REF}$  (-1dBFS). For  $V_{REF} = 3\text{V}$ , the corresponding recommended input range is 2.67V.

The analog inputs must be driven with a differential signal to achieve optimum performance. The recommended common-mode voltage of the input signal,  $V_{CM} = \frac{A\text{INP} + A\text{INN}}{2}$  is 2.5V.

In addition to the differential and common-mode input voltages, the absolute input voltage is also important. This is the voltage on either input (AINP or AINN) with respect to AGND. The range for this voltage is:

$$-0.1\text{ V} < (A\text{INN or AINP}) < 4.2\text{ V} \tag{1}$$

If either input is taken below  $-0.1\text{V}$ , ESD protection diodes on the inputs will turn on. Exceeding  $4.2\text{V}$  on either input will result in linearity performance degradation. ESD protection diodes will also turn on if the inputs are taken above  $AV_{DD} (+5\text{V})$ .

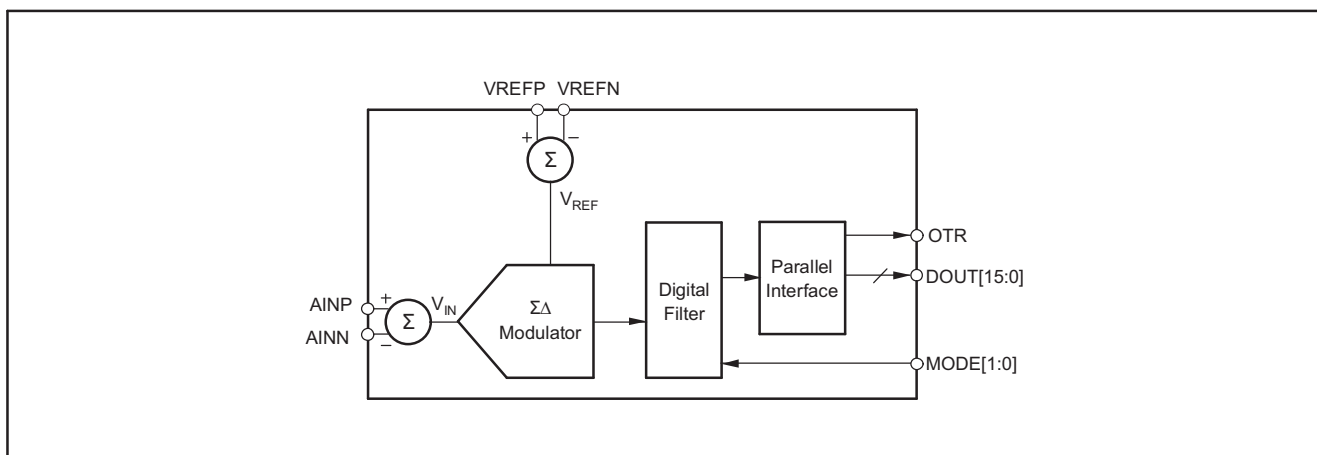

**Figure 24. Conceptual Block Diagram**

**INPUT CIRCUITRY**

The ADS1610 uses switched-capacitor circuitry to measure the input voltage. Internal capacitors are charged by the inputs and then discharged internally with this cycle repeating at the frequency of CLK. Figure 25 shows a conceptual diagram of these

circuits. Switches  $S_2$  represent the net effect of the modulator circuitry in discharging the sampling capacitors, the actual implementation is different. The timing for switches  $S_1$  and  $S_2$  is shown in Figure 26.

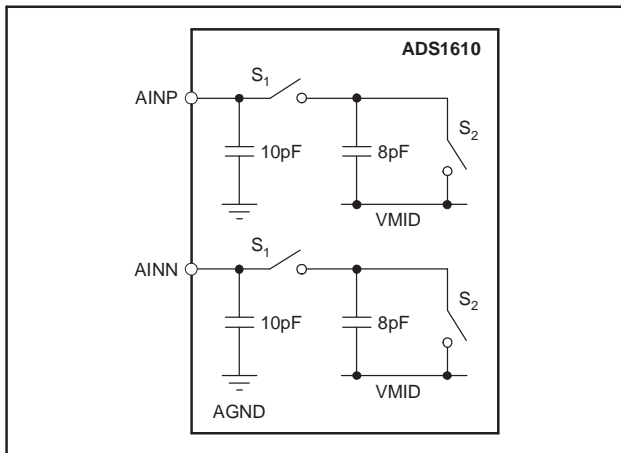

Figure 25. Conceptual Diagram of Internal Circuitry Connected to the Analog Inputs

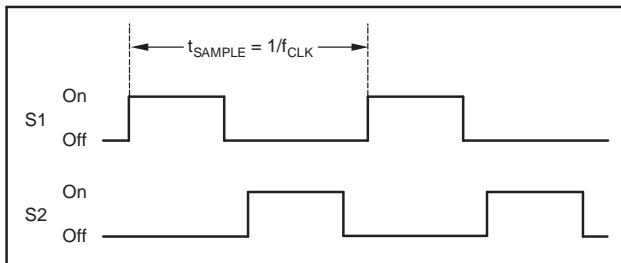

Figure 26. Timing for the Switches in Figure 25

## DRIVING THE INPUTS

The external circuits driving the ADS1610 inputs must be able to handle the load presented by the switching capacitors within the ADS1610. The input switches  $S_1$  in Figure 25 are closed approximately one half of the sampling period,  $t_{\text{SAMPLE}}$ , allowing only  $\sim 8$  ns for the internal capacitors to be charged by the inputs, when  $f_{\text{CLK}} = 60\text{MHz}$ .

Figure 27 and Figure 28 show the recommended circuits when using single-ended or differential op amps, respectively. The analog inputs must be driven differentially to achieve optimum performance. If only a single-ended input signal is available, the configuration in Figure 27 can be used by shorting  $-V_{\text{IN}}$  to ground.

This configuration would implement the single-ended to differential conversion.

The external capacitors, between the inputs and from each input to AGND, improve linearity and should be placed as close to the pins as possible. Place the drivers close to the inputs and use good capacitor bypass techniques on their supplies; usually a smaller high-quality ceramic capacitor in parallel with a larger capacitor. Keep the resistances used in the

driver circuits low-thermal noise in the driver circuits degrades the overall noise performance. When the signal can be AC-coupled to the ADS1610 inputs, a simple RC filter can set the input common mode voltage. The ADS1610 is a high-speed, high-performance ADC. Special care must be taken when selecting the test equipment and setup used with this device. Pay particular attention to the signal sources to ensure they do not limit performance when measuring the ADS1610.

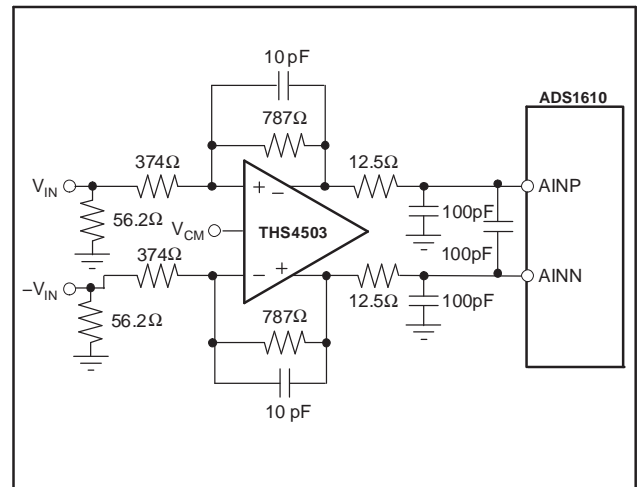
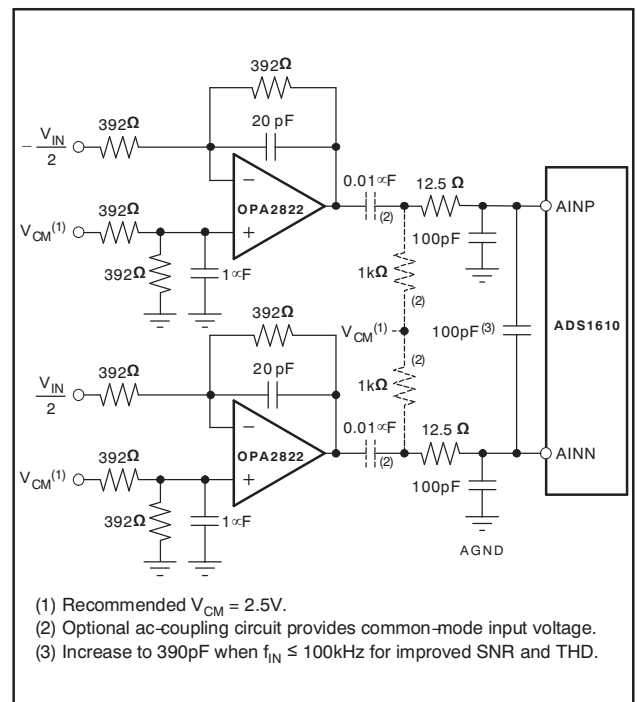

Figure 27. Recommended Single-Ended to Differential Conversion Circuit Using the THS4503 Differential Amplifier



- (1) Recommended  $V_{\text{CM}} = 2.5\text{V}$ .
- (2) Optional ac-coupling circuit provides common-mode input voltage.
- (3) Increase to 390pF when  $f_{\text{IN}} \leq 100\text{kHz}$  for improved SNR and THD.

Figure 28. Recommended Driver Circuit Using the OPA2822

### REFERENCE INPUTS (VREFN, VREFP, VMID)

The ADS1610 operates from an external voltage reference. The reference voltage ( $V_{ref}$ ) is set by the differential voltage between VREFN and VREFP:  $V_{ref} = (VREFP - VREFN)$ . VREFP and VREFN each use two pins, which should be shorted together. VMID, approximately 2.5V, is used by the modulator. VCAP connects to an internal node and must also be bypassed with an external capacitor.

The voltages applied to these pins must be within the values specified in the Electrical Characteristics table. Typically  $VREFP = 4V$ ,  $VMID = 2.5V$ , and  $VREFN = 1V$ . The external circuitry must be capable of providing both a DC and a transient current. Figure 29 shows a simplified diagram of the internal circuitry of the reference. As with the input circuitry, switches  $S_1$  and  $S_2$  open and close as shown in Figure 26.

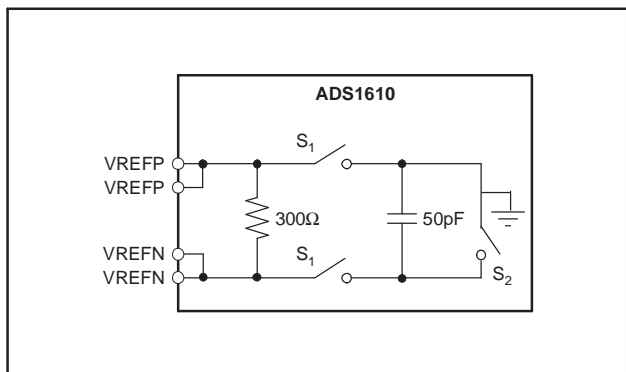

Figure 29. Conceptual Circuitry for the Reference Inputs

Figure 30 shows the recommended circuitry for driving these reference inputs. Keep the resistances used in the buffer circuits low to prevent excessive thermal noise from degrading performance. Layout of these circuits is critical, make sure to follow good high-speed layout practices. Place the buffers and especially the bypass capacitors as close to the pins as possible.

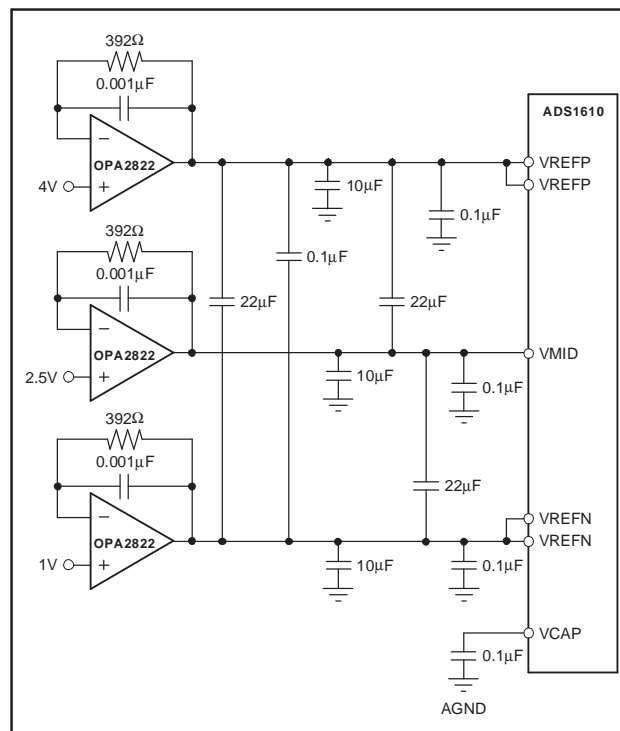

Figure 30. Recommended Reference Buffer Circuit

### CLOCK INPUT (CLK)

The ADS1610 uses an external clock signal to be applied to the CLK input pin. The sampling of the modulator is controlled by this clock signal. As with any high-speed data converter, a high quality clock is essential for optimum performance. Crystal clock oscillators are the recommended CLK source; other sources, such as frequency synthesizers may not be adequate. Make sure to avoid excess ringing on the CLK input; keeping the trace as short as possible will help.

Measuring high-frequency, large-amplitude signals requires tight control of clock jitter. The uncertainty during sampling of the input from clock jitter limits the maximum achievable SNR. This effect becomes more pronounced with higher frequency and larger magnitude inputs. The ADS1610 oversampling topology reduces clock jitter sensitivity over that of Nyquist rate converters like pipeline and successive approximation converters by a factor of  $\sqrt{6}$ .

In order to not limit the ADS1610 SNR performance, keep the jitter on the clock source below the values shown in Table 1. When measuring lower frequency and lower amplitude inputs, more CLK jitter can be tolerated. In determining the allowable clock source jitter, select the worst-case input (highest frequency, largest amplitude) that will be seen in the application.

## DATA FORMAT

The 16-bit output data is in binary two's complement format, as shown in Table 2. When the input is positive out-of-range, exceeding the positive full-scale value of  $V_{REF}$ , the output clips to all 7FFF<sub>H</sub> and the OTR output goes high.

**Table 1. Maximum Allowable Clock Source Jitter for Different Input Signal Frequencies and Amplitude**

INPUT SIGNAL		MAXIMUM ALLOWABLE CLOCK SOURCE JITTER
MAXIMUM FREQUENCY	MAXIMUM AMPLITUDE	
4MHz	–1dB	1.6ps
4MHz	–20dB	14ps
2MHz	–1dB	3.3ps
2MHz	–20dB	29ps
1MHz	–1dB	6.5ps
1MHz	–20dB	58ps
100kHz	–1dB	65ps
100kHz	–20dB	581ps

**Table 2. Output Code Versus Input Signal**

INPUT SIGNAL (INP – INN)	IDEAL OUTPUT CODE <sup>(1)</sup>	OTR
$\geq +V_{ref}$ (> 0dB)	7FFF <sub>H</sub>	1
$V_{ref}$ (0dB)	7FFF <sub>H</sub>	0
$\frac{+V_{REF}}{2^{15} - 1}$	0001 <sub>H</sub>	0
0	0000 <sub>H</sub>	0
$\frac{-V_{REF}}{2^{15} - 1}$	FFFF <sub>H</sub>	0
$-V_{REF} \left( \frac{2^{15}}{2^{15} - 1} \right)$	8000 <sub>H</sub>	0
$\leq -V_{REF} \left( \frac{2^{15}}{2^{15} - 1} \right)$	8000 <sub>H</sub>	1

<sup>(1)</sup>Excludes effects of noise, INL, offset and gain errors.

Likewise, when the input is negative out-of-range by going below the negative full-scale value of  $V_{ref}$ , the output clips to 8000<sub>H</sub> and the OTR output goes high. The OTR remains high while the input signal is out-of-range.

## OUT-OF-RANGE INDICATION (OTR)

If the output code on DOUT[15:0] exceeds the positive or negative full-scale, the out-of-range digital output (OTR) will go high on the falling edge of  $\overline{DRDY}$ . When the output code returns within the full-scale range, OTR returns low on the falling edge of  $\overline{DRDY}$ .

## DATA RETRIEVAL

Data retrieval is controlled through a simple parallel interface. The falling edge of the  $\overline{DRDY}$  output indicates new data is available. To activate the output bus, both  $\overline{CS}$  and  $\overline{RD}$  must be low, as shown in Table 3. Make sure the DOUT bus does not drive heavy loads (> 20pF), as this will degrade performance. Use an external buffer when driving an edge connector or cables.

**Table 3. Truth Table for  $\overline{CS}$  and  $\overline{RD}$**

$\overline{CS}$	$\overline{RD}$	DOUT [15:0]
0	0	Active
0	1	High impedance
1	0	High impedance
1	1	High impedance

## SYNCHRONISING MULTIPLE ADS1610s

The ADS1610 is asynchronously reset when the  $\overline{SYNC}$  pin is taken low. During reset, all of the digital circuits are cleared, DOUT[15:0] are forced low, and  $\overline{DRDY}$  forced high. It is recommended that the  $\overline{SYNC}$  pin be released on the falling edge of CLK. Afterwards,  $\overline{DRDY}$  goes low on the second rising edge of CLK. Allow 55  $\overline{DRDY}$  cycles for the digital filter to settle before retrieving data. See Figure 3 for the timing specifications.

Reset can be used to synchronize multiple ADS1610s. All devices to be synchronized must use a common CLK input. With the CLK inputs running, pulse  $\overline{SYNC}$  on the falling edge of CLK, as shown in Figure 31. Afterwards, the converters will be converting synchronously with the  $\overline{DRDY}$  outputs updating simultaneously. After synchronization, allow 55  $\overline{DRDY}$  cycles ( $t_{1,1}$ ) for output data to fully settle.

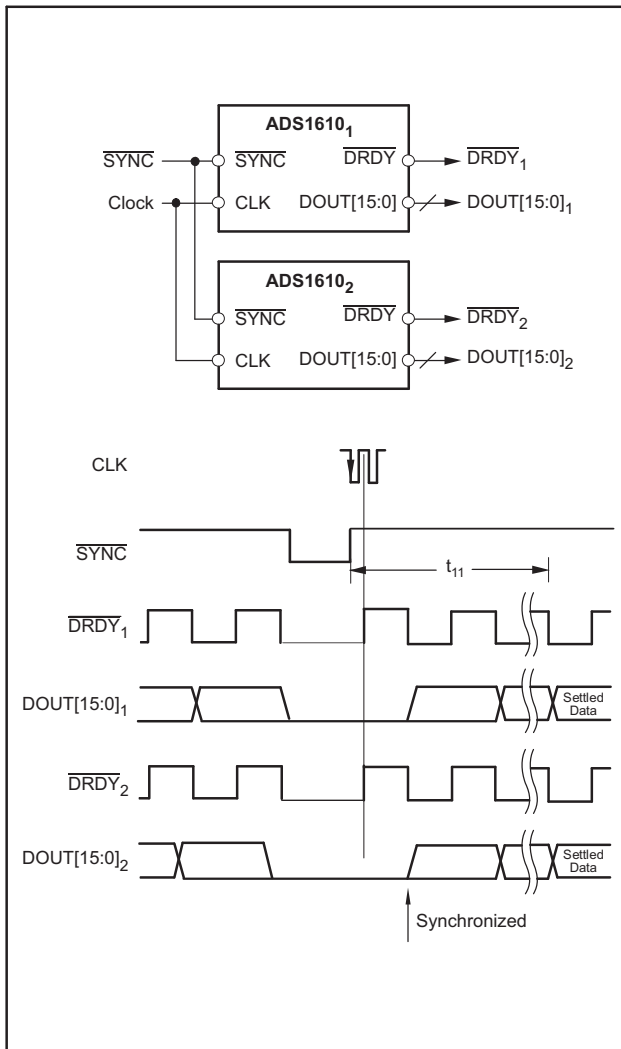

Figure 31. Synchronizing Multiple Converters

**SETTLING TIME**

The settling time is an important consideration when measuring signals with large steps or when using a multiplexer in front of the analog inputs. The ADS1610 digital filter requires time for an instantaneous change in signal level to propagate to the output.

Be sure to allow the filter time to settle after applying a large step in the input signal, switching the channel on a multiplexer placed in front of the inputs, resetting the ADS1610, or exiting the power-down mode.

Figure 32 shows the settling error as a function of time for a full-scale signal step applied at  $t = 0$ , with  $MODE = 00$  (See Table 4). This figure uses  $\overline{DRDY}$  cycles for the ADS1610 for the time scale (X-axis). After 55  $\overline{DRDY}$  cycles, the settling error drops below 0.001%. For  $f_{CLK} = 60\text{MHz}$ , this corresponds to a settling time of  $5.5\mu\text{s}$ .

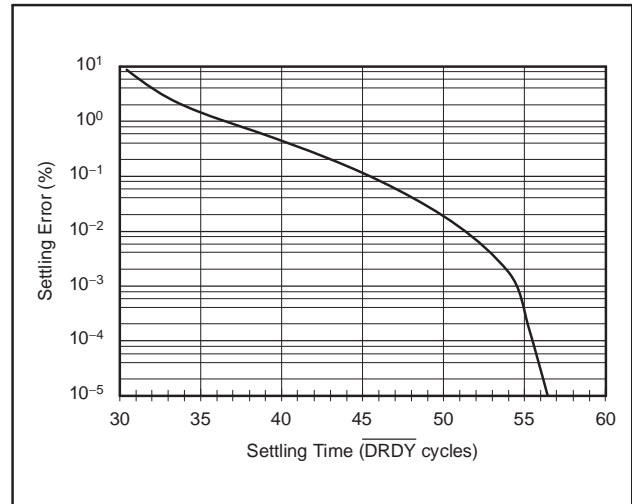

Figure 32. Settling Time

**IMPULSE RESPONSE**

Figure 33 plots the normalized response for an input applied at  $t = 0$ , with  $MODE = 00$ . The X-axis units of time are  $\overline{DRDY}$  cycles for the ADS1610. As shown in Figure 33, the peak of the impulse takes 30  $\overline{DRDY}$  cycles to propagate to the output. For  $f_{CLK} = 60\text{MHz}$ , a  $\overline{DRDY}$  cycle is  $0.1\mu\text{s}$  in duration and the propagation time (or group delay) is  $30 \times 0.1\mu\text{s} = 3.0\mu\text{s}$ .

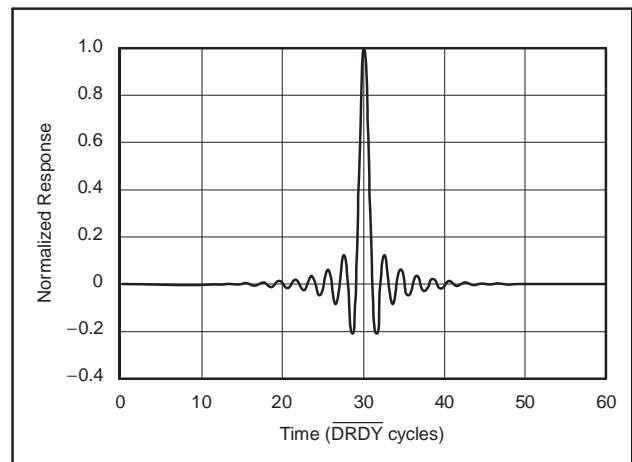

Figure 33. Impulse Response



## FREQUENCY RESPONSE

The linear phase FIR digital filter sets the overall frequency response. The decimation rate is set to 6 (MODE = 00) for all the figures shown in this section. Figure 34 shows the frequency response from DC to 30 MHz for  $f_{CLK} = 60$  MHz. The frequency response of the ADS1610 filter scales directly with CLK frequency. For example, if the CLK frequency is decreased by half (to 30 MHz), the values on the X-axis in Figure 34 would need to be scaled by half, with the span becoming DC to 15MHz.

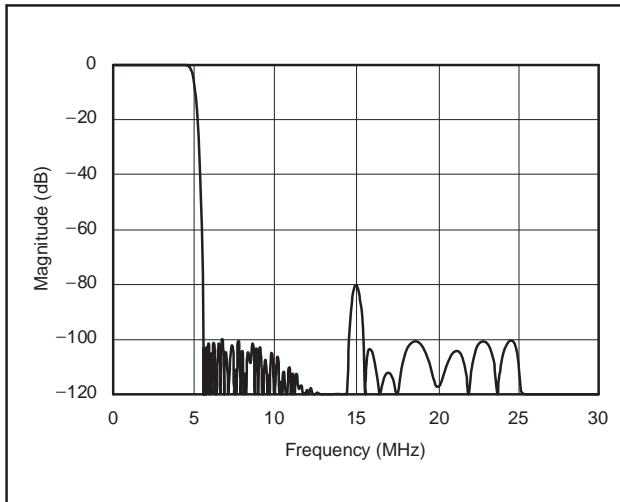

Figure 34. Frequency Response

Figure 35 shows the passband ripple from DC to 4.4MHz ( $f_{CLK} = 60$ MHz). Figure 36 shows a closer view of the passband transition by plotting the response from 4.0MHz to 5.0MHz ( $f_{CLK} = 60$ MHz).

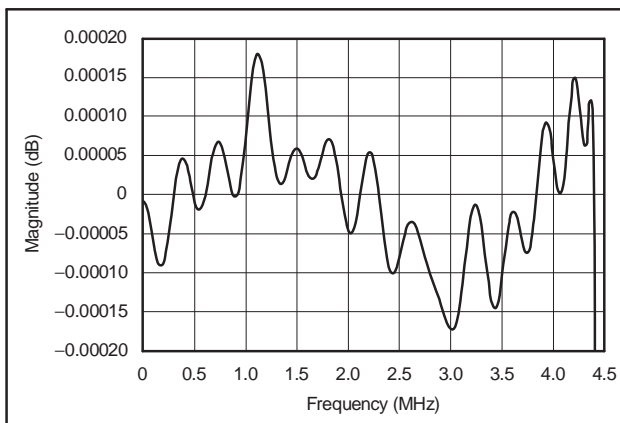

Figure 35. Passband Ripple

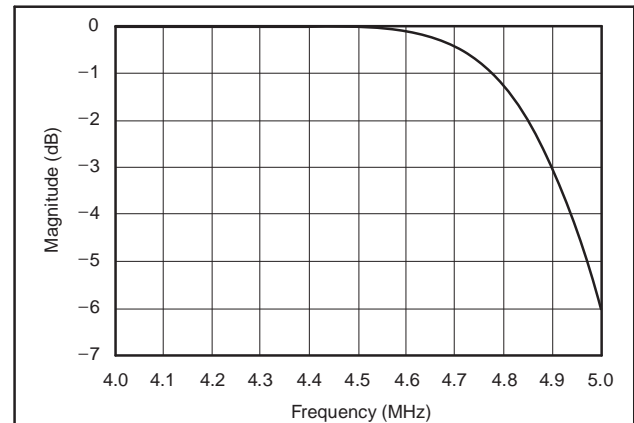

Figure 36. Passband Transition

The overall frequency response repeats at multiples of the CLK frequency. To help illustrate this, Figure 37 shows the response out to 180 MHz ( $f_{CLK} = 60$ MHz). Notice how the passband response repeats at 60MHz, 120MHz, and 180MHz; it is important to consider this sequence when there is high-frequency noise present with the signal. The modulator bandwidth extends to 100MHz. High-frequency noise around 60MHz and 120MHz will not be attenuated by either the modulator or the digital filter. This noise will alias back inband and reduce the overall SNR performance unless it is filtered out prior to the ADS1610. To prevent this, place an anti-alias filter in front of the ADS1610 that rolls off before 55MHz.

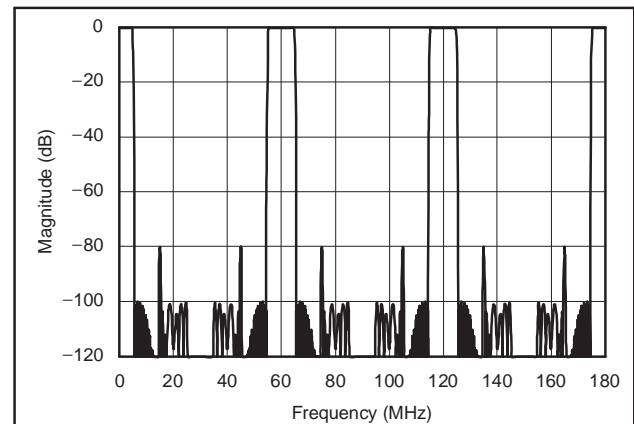
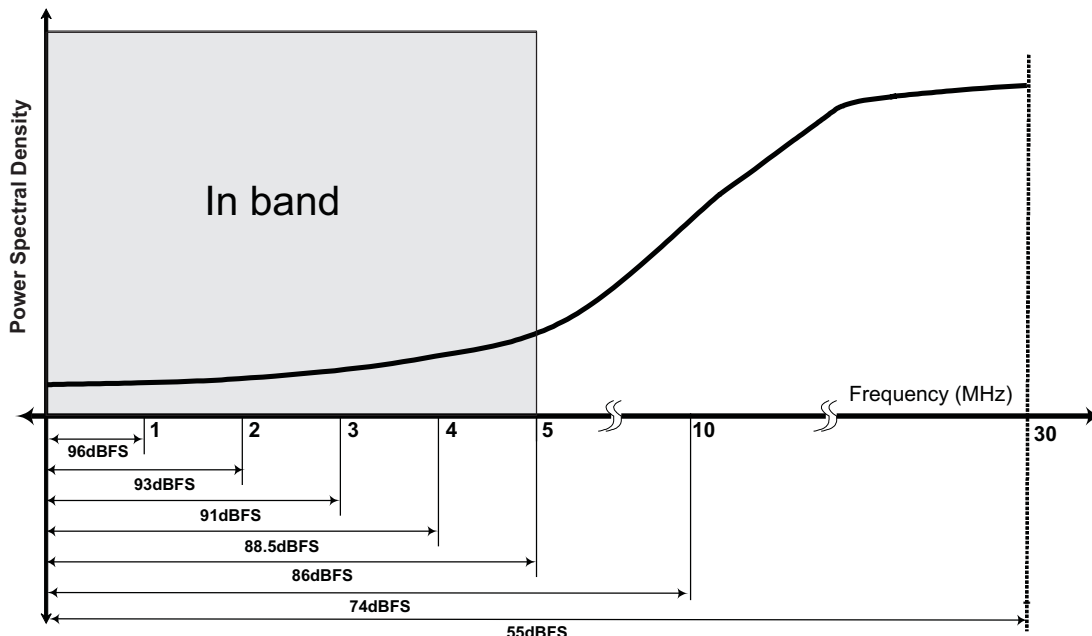

Figure 37. Frequency Response Out to 120MHz

### NOISE FLOOR

The ADS1610 is a delta sigma ADC and it uses noise shaping to achieve superior SNR performance. The noise floor of a typical successive approximation (SAR) or a pipeline ADC remains flat until the nyquist frequency occurs. A gain of 3dB in SNR can be achieved by averaging two samples, thereby having a tradeoff between output data rate and achievable SNR. In contrast, the noise floor of the ADS1610 inside the bandwidth of interest is shaped. Hence, the gain in SNR that can be achieved by averaging

two samples is more than 3dB. [Figure 38](#) below shows the typical in-band noise spectral density of the ADS1610. The numbers in the bottom of the figure represent the noise distribution with respect to a full-scale signal in different bandwidths of interest. The shaded area represents the signal bandwidth in the default mode of operation (10MHz output data rate).



**Figure 38. Typical Filter Bypass Mode Noise Spectral Density**

By using appropriate filtering the user can achieve a tradeoff between speed and SNR. For ease of use, the ADS1610 provides four filtering modes as explained in the next section. [Figure 39](#) shows a conceptual diagram of the available filtering modes. Custom filtering is achieved by taking the modulator output data and adding a filter externally.

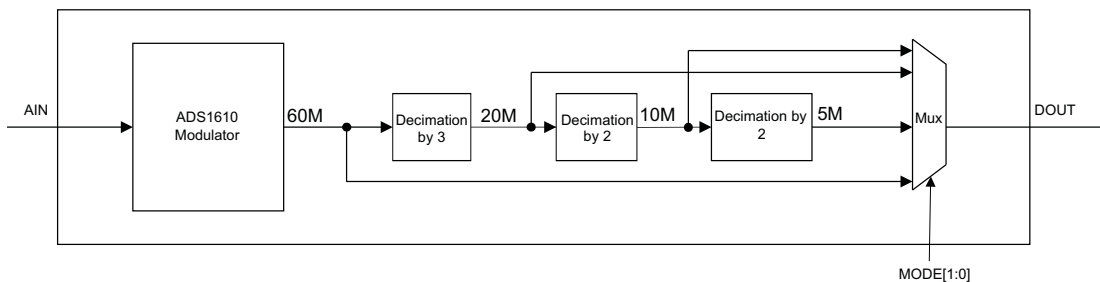

**Figure 39. Conceptual Diagram of the ADS1610 Filtering Modes**

### MODE SELECTION

ADS1610 offers four different modes of operation each with different output data rates. This gives users the flexibility to choose the best output rate for their application. The outputs of all modes are MSB-aligned.

Table 4. Four Modes of Operation<sup>(1)</sup>

Mode 1	Mode 0	OUTPUT RATE	OSR	SNR (TYP)	BITS	SETTLING TIME (DRDY cycles)
0	0	Default 10MHz mode	6	86dBFS	16	55
0	1	20MHz	3	74dBFS	14	25
1	0	5MHz	12	91dBFS	16	55
1	1	60MHz bypass mode	1	55dBFS	12	NA

(1) There is a pull-down resistor of 170kΩ on both mode pins; however, it is recommended that this pin be reduced to either high or low.

## 20MHz MODE

In this mode, the oversampling ratio is three. Decreasing the OSR from 6 to 3 doubles the data rate, at the same time the performance is reduced from 16 bits to 14 bits. Note that all 16 bits of DOUT remain active in this mode. For  $f_{clk} = 60\text{MHz}$ , the data rate is 20MSPS. In addition, the group delay becomes 1 μs or 13  $\overline{\text{DRDY}}$  cycles. In this mode the noise increases. Typical SNR performance degrades by 14dB. THD remains approximately the same.

## 5MHz MODE

In this mode the OSR is 12 for  $f_{clk} = 60\text{MHz}$  and the data rate is 5MSPS. Typical SNR performance increases by 4dB. THD remains approximately the same.

## 60MHz MODE

In this mode, decimation filters are bypassed. This data output can be filtered externally by the user. For  $f_{clk} = 60\text{MHz}$ , the data rate is 60MSPS.

## ANALOG POWER DISSIPATION

An external resistor connected between the RBIAS pin and the analog ground sets the analog current level, as shown in Figure 40. The current is inversely proportional to the resistor value. Table 5 shows the recommended values of RBIAS for different CLK frequencies. Notice that the analog current can be reduced when using a slower frequency CLK input because the modulator has more time to settle. Avoid adding any capacitance in parallel to RBIAS, since this will interfere with the internal circuitry used to set the biasing.

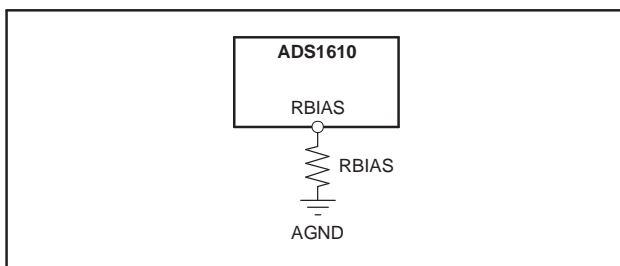

Figure 40. External Resistor Used to Set Analog Power Dissipation

Table 5. Recommended RBIAS Resistor Values for Different CLK Frequencies

$f_{CLK}$	DATA RATE	RBIAS	TYPICAL POWER DISSIPATION
42MHz	7MHz	45kΩ	550mW
48MHz	8MHz	37kΩ	640mW
54MHz	9MHz	31kΩ	720mW
60MHz	10MHz	19kΩ	960mW

## POWER-DOWN ( $\overline{\text{PD}}$ )

When not in use, the ADS1610 can be powered down by taking the  $\overline{\text{PD}}$  pin low. There is an internal pull-up resistor of 170kΩ on the  $\overline{\text{PD}}$  pin, but it is recommended that this pin be connected to DVDD if not used. Once the  $\overline{\text{PD}}$  pin is pulled high, allow at least  $t_{11}$  (see Timing Specification Table) DRDY cycles for the modulator and the digital filter to settle before retrieving data.

## POWER SUPPLIES

Two supplies are used on the ADS1610: analog (AVDD), and digital (DVDD). Each supply (other than DVDD pins 49 and 50) must be suitably bypassed to achieve the best performance. It is recommended that a 1μF and 0.1μF ceramic capacitor be placed as close to each supply pin as possible. Connect each supply-pin bypass capacitor to the associated ground, as shown in Figure 41. Each main supply bus should also be bypassed with a bank of capacitors from 47μF to 0.1μF, as shown in Figure 41.

For optimum performance, insert a 10Ω resistor in series with the AVDD2 supply (pin 58); the modulator clocking circuitry. This resistor decouples switching.

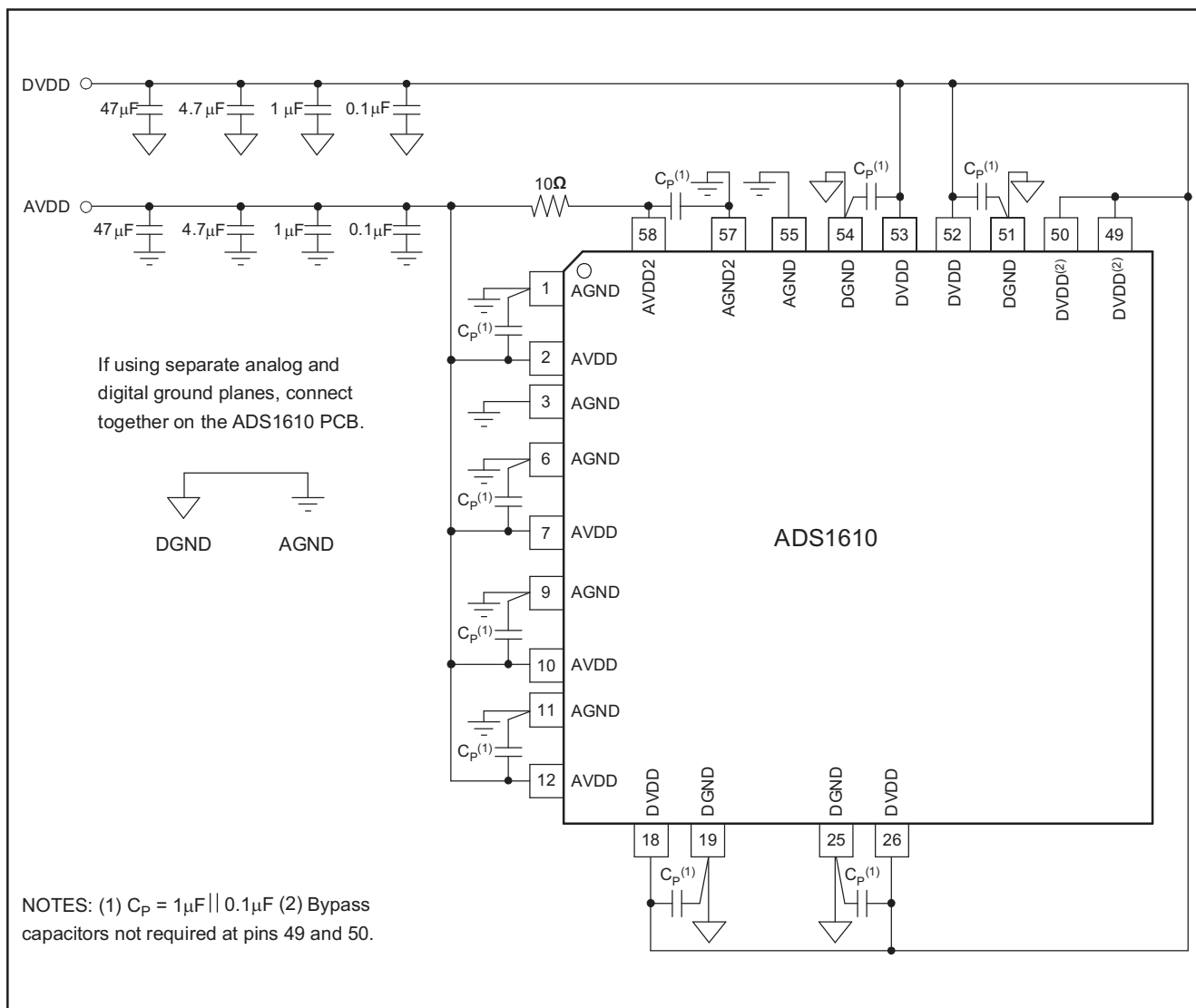

Figure 41. Recommended Power-Supply Bypassing

**LAYOUT ISSUES**

The ADS1610 is a very high-speed, high-resolution data converter. In order to achieve the maximum performance, careful attention must be given to the printed circuit board (PCB) layout. Use good high-speed techniques for all circuitry. Critical capacitors should be placed close to pins as possible. These include capacitors directly connected to the analog and reference inputs and the power supplies. Make sure to also properly bypass all circuitry driving the inputs and references.

Two approaches can be used for the ground planes: either a single common plane; or two separate

planes, one for the analog grounds and one for the digital grounds. When using only one common plane, isolate the flow of current on AGND2 (pin 57) from pin 1; use breaks on the ground plane to accomplish this. AGND2 carries the switching current from the analog clocking for the modulator and can corrupt the quiet analog ground on pin 1. When using two planes, it is recommended that they be tied together right at the PCB. Do not try to connect the ground planes together after running separately through edge connectors or cables as this reduces performance and increases the likelihood of latch-up.

In general, keep the resistances used in the driving circuits for the inputs and reference low to prevent excess thermal noise from degrading overall performance. Avoid having the ADS1610 digital outputs drive heavy loads. Buffers on the outputs are recommended unless the ADS1610 is connected directly to a DSP or controller situated nearby. Additionally, make sure the digital inputs are driven with clean signals as ringing on the inputs can introduce noise.

The ADS1610 uses TI PowerPAD™ technology. The PowerPAD is physically connected to the substrate of the silicon inside the package and must be soldered to the analog ground plane on the PCB using the exposed metal pad underneath the package for proper heat dissipation. See application report [SLMA002](#), located at [www.ti.com](http://www.ti.com), for more details on the PowerPAD package.

### APPLICATION INFORMATION

#### INTERFACING THE ADS1610 TO THE TMS320C6000

Figure 42 illustrates how to directly connect the ADS1610 to the TMS320C6000 DSP. The processor controls the reading using output  $\overline{ARE}$ . The ADS1610 is selected using the DSP control output,  $\overline{CE2}$ . The ADS1610 16-bit data output bus is directly connected to the TMS320C6000 data bus. The data ready output ( $\overline{DRDY}$ ) from the ADS1610 drives interrupt  $\overline{EXT\_INT7}$  on the TMS320C6000.

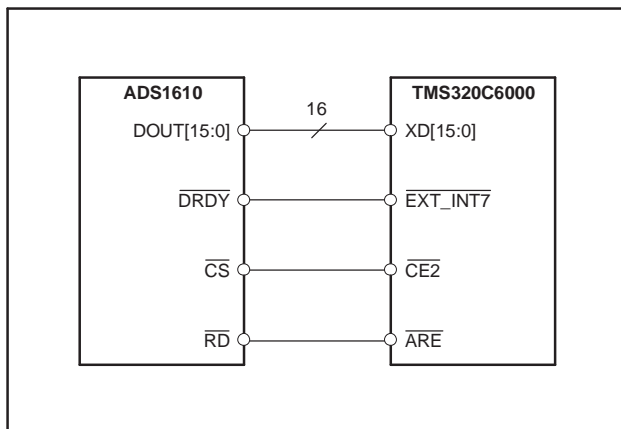
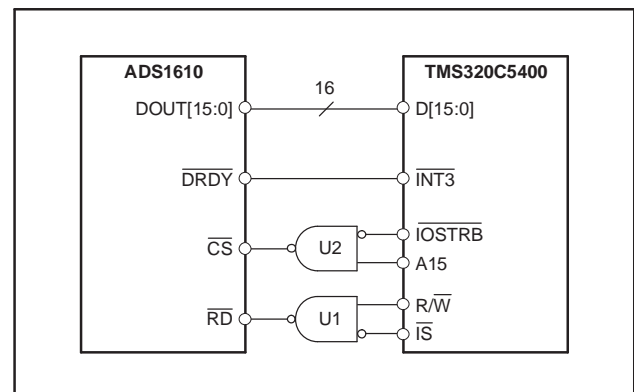

**Figure 42. ADS1610 – TMS320C6000 Interface Connection**

#### INTERFACING THE ADS1610 TO THE TMS320C5400

Figure 43 illustrates how to connect the ADS1610 to the TMS320C5400 DSP. The processor controls the reading using the outputs  $R/\overline{W}$  and  $\overline{IS}$ . The I/O space-select signal ( $\overline{IS}$ ) is optional and is used to prevent the ADS1610  $\overline{RD}$  input from being strobed when the DSP is accessing other external memory

spaces (address or data). This can help reduce the possibility of digital noise coupling into the ADS1610. When not using this signal, replace NAND gate U1 with an inverter between  $R/\overline{W}$  and  $\overline{RD}$ . Two signals,  $\overline{IOSTRB}$  and A15, combine using NAND gate U2 to select the ADS1610. If there are no additional devices connected to the TMS320C5400 I/O space, U2 can be eliminated. Simply connect  $\overline{IOSTRB}$  directly to  $\overline{CS}$ . The ADS1610 16-bit data output bus is directly connected to the TMS320C5400 data bus. The data ready output ( $\overline{DRDY}$ ) from the ADS1610 drives interrupt  $\overline{INT3}$  on the TMS320C5400.



**Figure 43. ADS1610 – TMS320C5400 Interface Connection**

Code Composer Studio, available from TI, provides support for interfacing TI DSPs through a collection of data converter plug-ins. Check the TI website, located at [www.ti.com/sc/dcplug-in](http://www.ti.com/sc/dcplug-in), for the latest information on ADS1610 support.

**PACKAGING INFORMATION**

Orderable Device	Status <sup>(1)</sup>	Package Type	Package Drawing	Pins	Package Qty	Eco Plan <sup>(2)</sup>	Lead/Ball Finish	MSL Peak Temp <sup>(3)</sup>
ADS1610IPAPR	ACTIVE	HTQFP	PAP	64	1000	Green (RoHS & no Sb/Br)	CU NIPDAU	Level-3-260C-168 HR
ADS1610IPAPRG4	ACTIVE	HTQFP	PAP	64	1000	Green (RoHS & no Sb/Br)	CU NIPDAU	Level-3-260C-168 HR
ADS1610IPAPT	ACTIVE	HTQFP	PAP	64	250	Green (RoHS & no Sb/Br)	CU NIPDAU	Level-3-260C-168 HR
ADS1610IPAPTG4	ACTIVE	HTQFP	PAP	64	250	Green (RoHS & no Sb/Br)	CU NIPDAU	Level-3-260C-168 HR

<sup>(1)</sup> The marketing status values are defined as follows:

**ACTIVE:** Product device recommended for new designs.

**LIFEBUY:** TI has announced that the device will be discontinued, and a lifetime-buy period is in effect.

**NRND:** Not recommended for new designs. Device is in production to support existing customers, but TI does not recommend using this part in a new design.

**PREVIEW:** Device has been announced but is not in production. Samples may or may not be available.

**OBSOLETE:** TI has discontinued the production of the device.

<sup>(2)</sup> Eco Plan - The planned eco-friendly classification: Pb-Free (RoHS), Pb-Free (RoHS Exempt), or Green (RoHS & no Sb/Br) - please check <http://www.ti.com/productcontent> for the latest availability information and additional product content details.

**TBD:** The Pb-Free/Green conversion plan has not been defined.

**Pb-Free (RoHS):** TI's terms "Lead-Free" or "Pb-Free" mean semiconductor products that are compatible with the current RoHS requirements for all 6 substances, including the requirement that lead not exceed 0.1% by weight in homogeneous materials. Where designed to be soldered at high temperatures, TI Pb-Free products are suitable for use in specified lead-free processes.

**Pb-Free (RoHS Exempt):** This component has a RoHS exemption for either 1) lead-based flip-chip solder bumps used between the die and package, or 2) lead-based die adhesive used between the die and leadframe. The component is otherwise considered Pb-Free (RoHS compatible) as defined above.

**Green (RoHS & no Sb/Br):** TI defines "Green" to mean Pb-Free (RoHS compatible), and free of Bromine (Br) and Antimony (Sb) based flame retardants (Br or Sb do not exceed 0.1% by weight in homogeneous material)

<sup>(3)</sup> MSL, Peak Temp. -- The Moisture Sensitivity Level rating according to the JEDEC industry standard classifications, and peak solder temperature.

**Important Information and Disclaimer:**The information provided on this page represents TI's knowledge and belief as of the date that it is provided. TI bases its knowledge and belief on information provided by third parties, and makes no representation or warranty as to the accuracy of such information. Efforts are underway to better integrate information from third parties. TI has taken and continues to take reasonable steps to provide representative and accurate information but may not have conducted destructive testing or chemical analysis on incoming materials and chemicals. TI and TI suppliers consider certain information to be proprietary, and thus CAS numbers and other limited information may not be available for release.

In no event shall TI's liability arising out of such information exceed the total purchase price of the TI part(s) at issue in this document sold by TI to Customer on an annual basis.

PAP (S-PQFP-G64)

PowerPAD™ PLASTIC QUAD FLATPACK

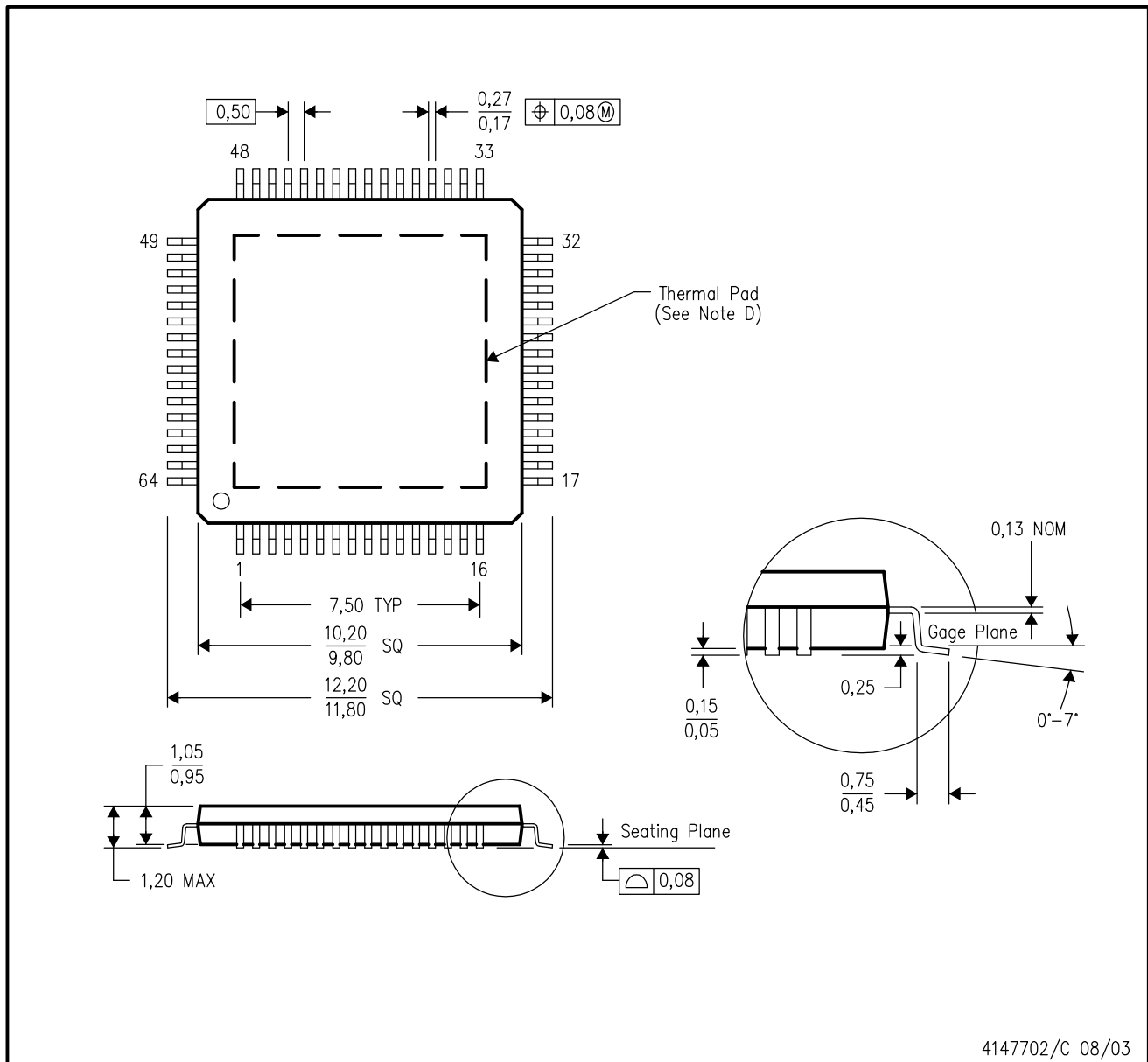

- NOTES:
- A. All linear dimensions are in millimeters.
  - B. This drawing is subject to change without notice.
  - C. Body dimensions do not include mold flash or protrusion
  - D. This package is designed to be soldered to a thermal pad on the board. Refer to Technical Brief, PowerPad Thermally Enhanced Package, Texas Instruments Literature No. SLMA002 for information regarding recommended board layout. This document is available at [www.ti.com](http://www.ti.com) <<http://www.ti.com>>.
  - E. Falls within JEDEC MS-026

PowerPAD is a trademark of Texas Instruments.

**THERMAL INFORMATION**

This PowerPAD™ package incorporates an exposed thermal pad that is designed to be attached to a printed circuit board (PCB). The thermal pad must be soldered directly to the PCB. After soldering, the PCB can be used as a heatsink. In addition, through the use of thermal vias, the thermal pad can be attached directly to the appropriate copper plane shown in the electrical schematic for the device, or alternatively, can be attached to a special heatsink structure designed into the PCB. This design optimizes the heat transfer from the integrated circuit (IC).

For additional information on the PowerPAD package and how to take advantage of its heat dissipating abilities, refer to Technical Brief, PowerPAD Thermally Enhanced Package, Texas Instruments Literature No. SLMA002 and Application Brief, PowerPAD Made Easy, Texas Instruments Literature No. SLMA004. Both documents are available at www.ti.com.

The exposed thermal pad dimensions for this package are shown in the following illustration.

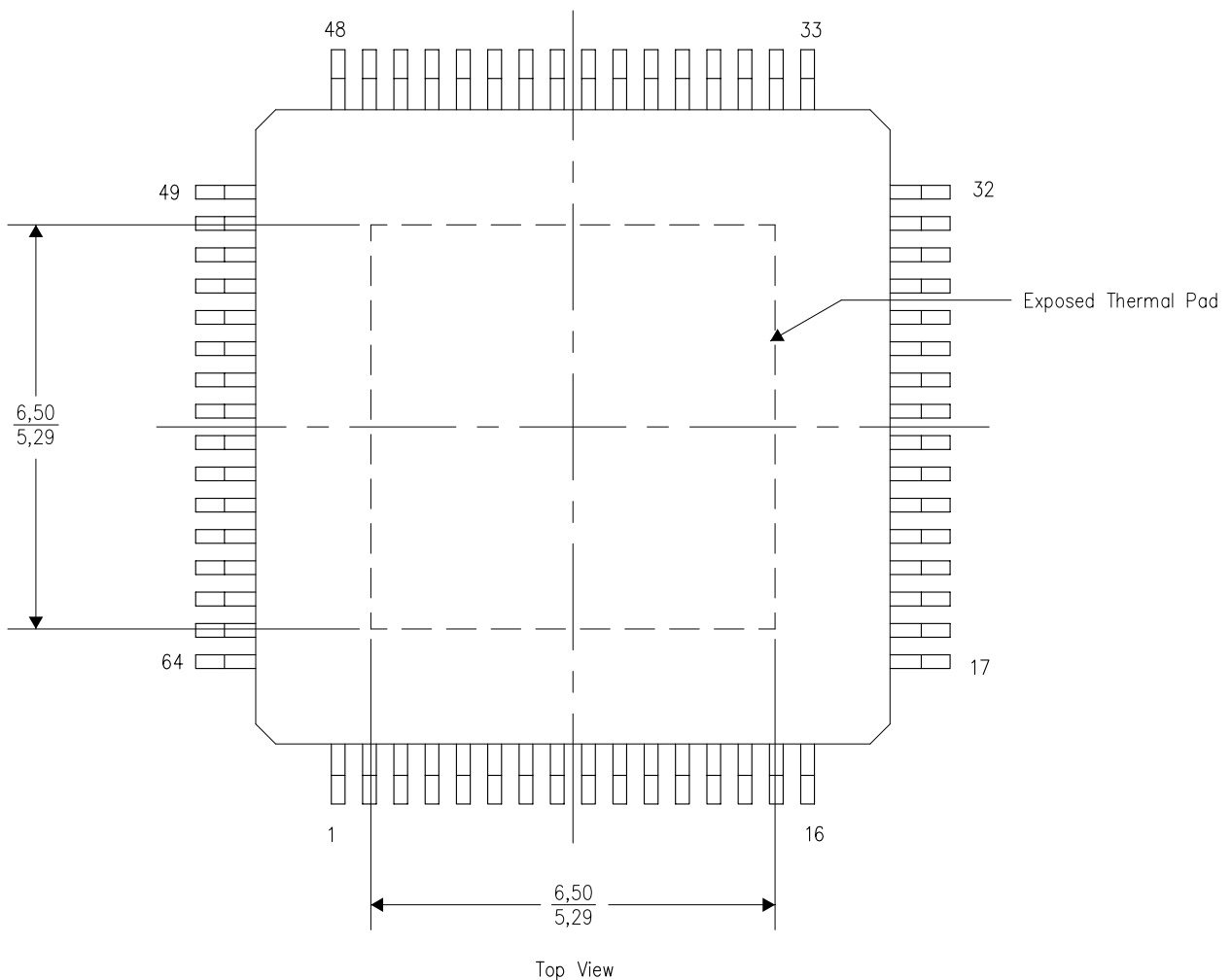

NOTE: All linear dimensions are in millimeters

Exposed Thermal Pad Dimensions



## PAP (S-PQFP-G64) PowerPAD™

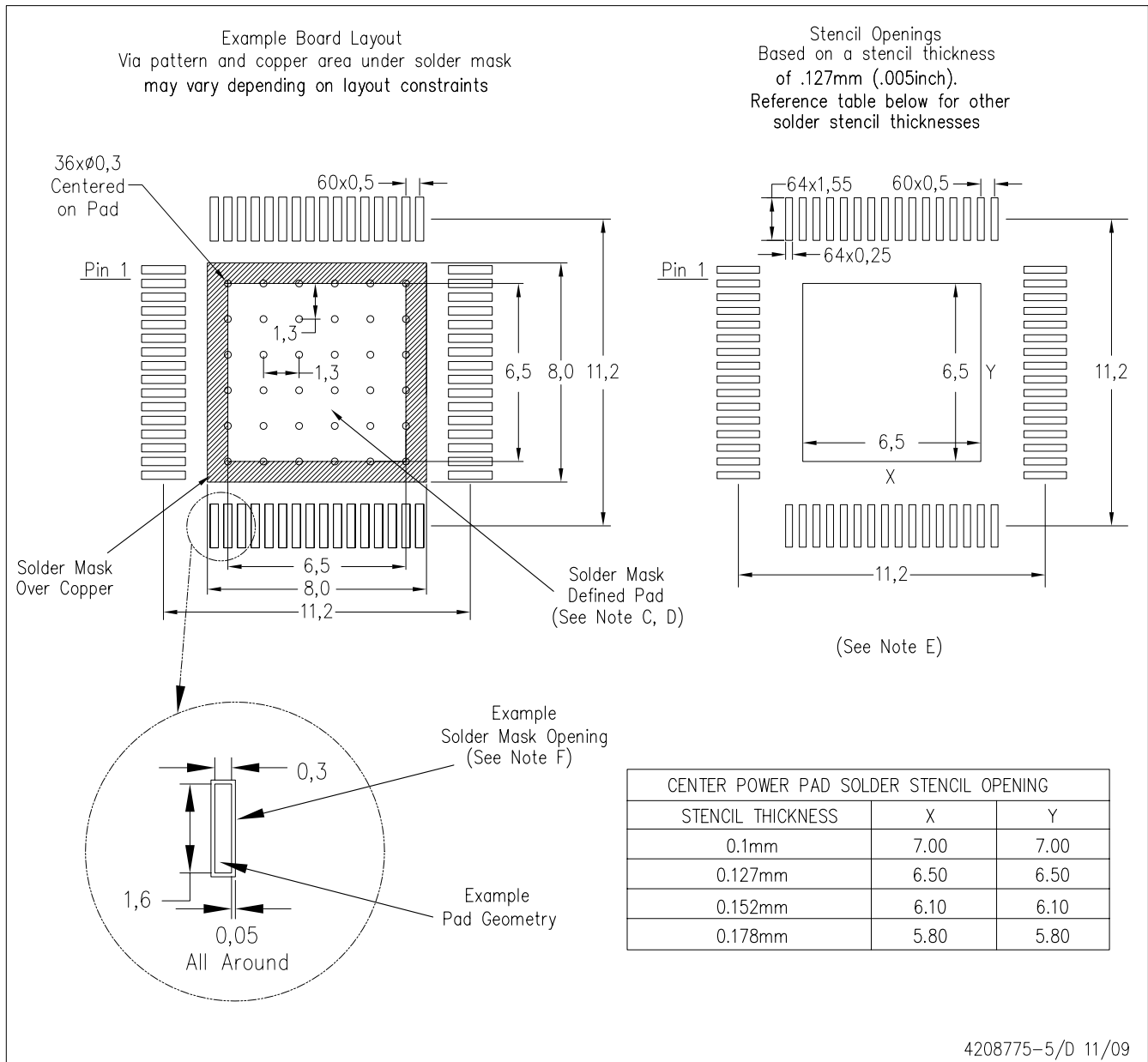

- NOTES:
- All linear dimensions are in millimeters.
  - This drawing is subject to change without notice.
  - Customers should place a note on the circuit board fabrication drawing not to alter the center solder mask defined pad.
  - This package is designed to be soldered to a thermal pad on the board. Refer to Technical Brief, PowerPAD Thermally Enhanced Package, Texas Instruments Literature No. SLMA002, SLMA004, and also the Product Data Sheets for specific thermal information, via requirements, and recommended board layout. These documents are available at [www.ti.com](http://www.ti.com) <<http://www.ti.com>>. Publication IPC-7351 is recommended for alternate designs.
  - Laser cutting apertures with trapezoidal walls and also rounding corners will offer better paste release. Customers should contact their board assembly site for stencil design recommendations. Example stencil design based on a 50% volumetric metal load solder paste. Refer to IPC-7525 for other stencil recommendations.
  - Customers should contact their board fabrication site for solder mask tolerances between and around signal pads.

## IMPORTANT NOTICE

Texas Instruments Incorporated and its subsidiaries (TI) reserve the right to make corrections, modifications, enhancements, improvements, and other changes to its products and services at any time and to discontinue any product or service without notice. Customers should obtain the latest relevant information before placing orders and should verify that such information is current and complete. All products are sold subject to TI's terms and conditions of sale supplied at the time of order acknowledgment.

TI warrants performance of its hardware products to the specifications applicable at the time of sale in accordance with TI's standard warranty. Testing and other quality control techniques are used to the extent TI deems necessary to support this warranty. Except where mandated by government requirements, testing of all parameters of each product is not necessarily performed.

TI assumes no liability for applications assistance or customer product design. Customers are responsible for their products and applications using TI components. To minimize the risks associated with customer products and applications, customers should provide adequate design and operating safeguards.

TI does not warrant or represent that any license, either express or implied, is granted under any TI patent right, copyright, mask work right, or other TI intellectual property right relating to any combination, machine, or process in which TI products or services are used. Information published by TI regarding third-party products or services does not constitute a license from TI to use such products or services or a warranty or endorsement thereof. Use of such information may require a license from a third party under the patents or other intellectual property of the third party, or a license from TI under the patents or other intellectual property of TI.

Reproduction of TI information in TI data books or data sheets is permissible only if reproduction is without alteration and is accompanied by all associated warranties, conditions, limitations, and notices. Reproduction of this information with alteration is an unfair and deceptive business practice. TI is not responsible or liable for such altered documentation. Information of third parties may be subject to additional restrictions.

Resale of TI products or services with statements different from or beyond the parameters stated by TI for that product or service voids all express and any implied warranties for the associated TI product or service and is an unfair and deceptive business practice. TI is not responsible or liable for any such statements.

TI products are not authorized for use in safety-critical applications (such as life support) where a failure of the TI product would reasonably be expected to cause severe personal injury or death, unless officers of the parties have executed an agreement specifically governing such use. Buyers represent that they have all necessary expertise in the safety and regulatory ramifications of their applications, and acknowledge and agree that they are solely responsible for all legal, regulatory and safety-related requirements concerning their products and any use of TI products in such safety-critical applications, notwithstanding any applications-related information or support that may be provided by TI. Further, Buyers must fully indemnify TI and its representatives against any damages arising out of the use of TI products in such safety-critical applications.

TI products are neither designed nor intended for use in military/aerospace applications or environments unless the TI products are specifically designated by TI as military-grade or "enhanced plastic." Only products designated by TI as military-grade meet military specifications. Buyers acknowledge and agree that any such use of TI products which TI has not designated as military-grade is solely at the Buyer's risk, and that they are solely responsible for compliance with all legal and regulatory requirements in connection with such use.

TI products are neither designed nor intended for use in automotive applications or environments unless the specific TI products are designated by TI as compliant with ISO/TS 16949 requirements. Buyers acknowledge and agree that, if they use any non-designated products in automotive applications, TI will not be responsible for any failure to meet such requirements.

Following are URLs where you can obtain information on other Texas Instruments products and application solutions:

<b>Products</b>		<b>Applications</b>	
Amplifiers	<a href="http://amplifier.ti.com">amplifier.ti.com</a>	Audio	<a href="http://www.ti.com/audio">www.ti.com/audio</a>
Data Converters	<a href="http://dataconverter.ti.com">dataconverter.ti.com</a>	Automotive	<a href="http://www.ti.com/automotive">www.ti.com/automotive</a>
DLP® Products	<a href="http://www.dlp.com">www.dlp.com</a>	Communications and Telecom	<a href="http://www.ti.com/communications">www.ti.com/communications</a>
DSP	<a href="http://dsp.ti.com">dsp.ti.com</a>	Computers and Peripherals	<a href="http://www.ti.com/computers">www.ti.com/computers</a>
Clocks and Timers	<a href="http://www.ti.com/clocks">www.ti.com/clocks</a>	Consumer Electronics	<a href="http://www.ti.com/consumer-apps">www.ti.com/consumer-apps</a>
Interface	<a href="http://interface.ti.com">interface.ti.com</a>	Energy	<a href="http://www.ti.com/energy">www.ti.com/energy</a>
Logic	<a href="http://logic.ti.com">logic.ti.com</a>	Industrial	<a href="http://www.ti.com/industrial">www.ti.com/industrial</a>
Power Mgmt	<a href="http://power.ti.com">power.ti.com</a>	Medical	<a href="http://www.ti.com/medical">www.ti.com/medical</a>
Microcontrollers	<a href="http://microcontroller.ti.com">microcontroller.ti.com</a>	Security	<a href="http://www.ti.com/security">www.ti.com/security</a>
RFID	<a href="http://www.ti-rfid.com">www.ti-rfid.com</a>	Space, Avionics & Defense	<a href="http://www.ti.com/space-avionics-defense">www.ti.com/space-avionics-defense</a>
RF/IF and ZigBee® Solutions	<a href="http://www.ti.com/lprf">www.ti.com/lprf</a>	Video and Imaging	<a href="http://www.ti.com/video">www.ti.com/video</a>
		Wireless	<a href="http://www.ti.com/wireless-apps">www.ti.com/wireless-apps</a>

Mailing Address: Texas Instruments, Post Office Box 655303, Dallas, Texas 75265  
Copyright © 2010, Texas Instruments Incorporated

[www.BDTIC.com/TI/](http://www.BDTIC.com/TI/)