



18-Bit, 1.25MSPS Analog-to-Digital Converter

FEATURES

- **Data Rate: 1.25MSPS**
- **Signal-to-Noise Ratio: 93dB**
- **Total Harmonic Distortion: –101dB**
- **Spurious-Free Dynamic Range: 103dB**
- **Linear Phase with 615kHz Bandwidth**
- **Passband Ripple: ± 0.0025 dB**
- **Adjustable FIFO Output Buffer (ADS1626 only)**
- **Selectable On-Chip Reference**
- **Directly Connects to TMS320C6000 DSPs**
- **Adjustable Power Dissipation: 150 to 515mW**
- **Power Down Mode**
- **Supplies: Analog +5V**
 Digital +3V
 Digital I/O +2.7V to +5.25V

APPLICATIONS

- **Scientific Instruments**
- **Automated Test Equipment**
- **Data Acquisition**
- **Medical Imaging**
- **Vibration Analysis**

DESCRIPTION

The ADS1625 and ADS1626 are high-speed, high-precision, delta-sigma analog-to-digital converters (ADCs) with 18-bit resolution. The data rate is 1.25 mega samples per second (MSPS), the bandwidth (-3 dB) is 615kHz, and passband ripple is less than ± 0.0025 dB (to 550kHz). Both devices offer the same outstanding performance at these speeds with a signal-to-noise ratio up to 93dB, total harmonic distortion down to -101 dB, and a spurious-free dynamic range up to 103dB. The ADS1626 includes an adjustable first-in, first-out buffer (FIFO) for the output data.

The input signal is measured against a voltage reference that can be generated on-chip or supplied externally. The digital output data are provided over a simple parallel interface that easily connects to digital signal processors (DSPs). An out-of-range monitor reports when the input range has been exceeded. The ADS1625/6 operate from a +5V analog supply (AVDD) and +3V digital supply (DVDD). The digital I/O supply (IOVDD) operates from +2.7 to +5.25V, enabling the digital interface to support a range of logic families. The analog power dissipation is set by an external resistor and can be reduced when operating at slower speeds. A power-down mode, activated by a digital I/O pin, shuts down all circuitry. The ADS1625/6 are offered in a TQFP-64 package using TI PowerPAD™ technology.

The ADS1625 and ADS1626, along with their 16-bit, 5MSPS counterparts, the ADS1605 and ADS1606, are well-suited for the demanding measurement requirements of scientific instrumentation, automated test equipment, data acquisition, and medical imaging.

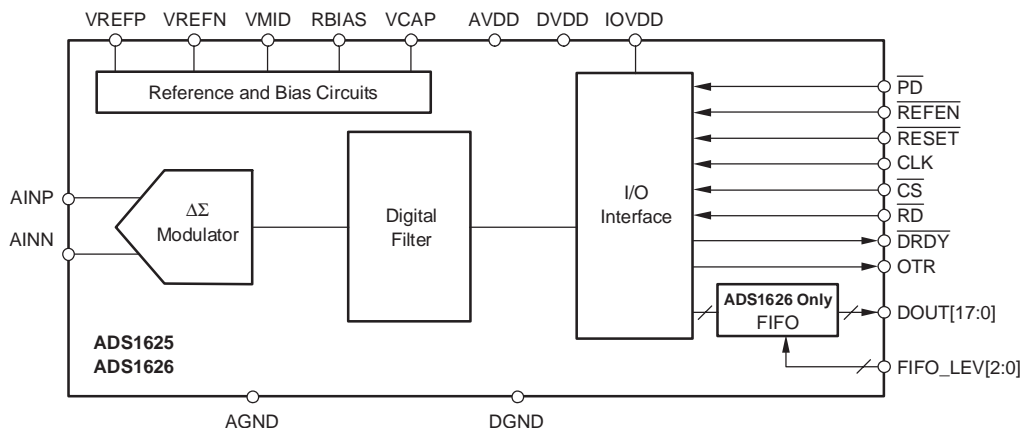

Please be aware that an important notice concerning availability, standard warranty, and use in critical applications of Texas Instruments semiconductor products and disclaimers thereto appears at the end of this data sheet.

PowerPAD is a trademark of Texas Instruments. All other trademarks are the property of their respective owners.

ORDERING INFORMATION

PRODUCT	PACKAGE-LEAD	PACKAGE DESIGNATOR(1)	SPECIFIED TEMPERATURE RANGE	PACKAGE MARKING	ORDERING NUMBER	TRANSPORT MEDIA, QUANTITY
ADS1625	HTQFP-64	PAP	-40°C to +85°C	ADS1625I	ADS1625IPAPT	Tape and Reel, 250
					ADS1625IPAPR	Tape and Reel, 1000
ADS1626	HTQFP-64	PAP	-40°C to +85°C	ADS1626I	ADS1626IPAPT	Tape and Reel, 250
					ADS1626IPAPR	Tape and Reel, 1000

(1) For the most current specifications and package information, refer to our web site at www.ti.com.

ABSOLUTE MAXIMUM RATINGS

over operating free-air temperature range unless otherwise noted(1)

	ADS1625/26	UNIT
AVDD to AGND	-0.3 to +6	V
DVDD to DGND	-0.3 to +3.6	V
IOVDD to DGND	-0.3 to +6	V
AGND to DGND	-0.3 to +0.3	V
Input Current	100, Momentary	mA
Input Current	10, Continuous	mA
Analog I/O to AGND	-0.3 to AVDD + 0.3	V
Digital I/O to DGND	-0.3 to IOVDD + 0.3	V
Maximum Junction Temperature	+150	°C
Operating Temperature Range	-40 to +105	°C
Storage Temperature Range	-60 to +150	°C
Lead Temperature (soldering, 10s)	+260	°C

(1) Stresses above these ratings may cause permanent damage. Exposure to absolute maximum conditions for extended periods may degrade device reliability. These are stress ratings only, and functional operation of the device at these or any other conditions beyond those specified is not implied.

PRODUCT FAMILY

PRODUCT	RESOLUTION	DATA RATE	FIFO?
ADS1605	16 Bits	5.0MSPS	No
ADS1606	16 Bits	5.0MSPS	Yes
ADS1625	18 Bits	1.25MSPS	No
ADS1626	18 Bits	1.25MSPS	Yes



This integrated circuit can be damaged by ESD. Texas Instruments recommends that all integrated circuits be handled with appropriate precautions. Failure to observe proper handling and installation procedures can cause damage.

ESD damage can range from subtle performance degradation to complete device failure. Precision integrated circuits may be more susceptible to damage because very small parametric changes could cause the device not to meet its published specifications.

ELECTRICAL CHARACTERISTICS

All specifications at -40°C to $+85^{\circ}\text{C}$, $\text{AVDD} = 5\text{V}$, $\text{DVDD} = \text{IOVDD} = 3\text{V}$, $f_{\text{CLK}} = 40\text{MHz}$, External $V_{\text{REF}} = +3\text{V}$, $V_{\text{CM}} = 2.0\text{V}$, FIFO disabled, and $\text{RBIAS} = 37\text{k}\Omega$, unless otherwise noted.

PARAMETER	TEST CONDITIONS	MIN	TYP	MAX	UNIT
Analog Input					
Differential input voltage (V_{IN}) ($\text{AINP} - \text{AINN}$)	0dBFS		$\pm 1.467V_{\text{REF}}$		V
	-2dBFS		$\pm 1.165V_{\text{REF}}$		V
	-6dBFS		$\pm 0.735V_{\text{REF}}$		V
	-20dBFS		$\pm 0.147V_{\text{REF}}$		V
Common-mode input voltage (V_{CM}) ($\text{AINP} + \text{AINN}$) / 2			2.0		V
Absolute input voltage (AINP or AINN with respect to AGND)	0dBFS	-0.1		4.7	V
	-2dBFS input and smaller	0.1		4.2	V
Dynamic Specifications					
Data rate			$1.25 \left(\frac{f_{\text{CLK}}}{40\text{MHz}} \right)$		MSPS
Signal-to-noise ratio (SNR)	$f_{\text{IN}} = 10\text{kHz}$, -2dBFS		93		dB
	$f_{\text{IN}} = 10\text{kHz}$, -6dBFS		90		dB
	$f_{\text{IN}} = 10\text{kHz}$, -20dBFS		76		dB
	$f_{\text{IN}} = 100\text{kHz}$, -2dBFS		93		dB
	$f_{\text{IN}} = 100\text{kHz}$, -6dBFS		90		dB
	$f_{\text{IN}} = 100\text{kHz}$, -20dBFS	70	76		dB
	$f_{\text{IN}} = 500\text{kHz}$, -2dBFS		93		dB
	$f_{\text{IN}} = 500\text{kHz}$, -6dBFS		90		dB
	$f_{\text{IN}} = 500\text{kHz}$, -20dBFS		76		dB
Total harmonic distortion (THD)	$f_{\text{IN}} = 10\text{kHz}$, -2dBFS		-101		dB
	$f_{\text{IN}} = 10\text{kHz}$, -6dBFS		-103		dB
	$f_{\text{IN}} = 10\text{kHz}$, -20dBFS		-96		dB
	$f_{\text{IN}} = 100\text{kHz}$, -2dBFS		-95		dB
	$f_{\text{IN}} = 100\text{kHz}$, -6dBFS		-101		dB
	$f_{\text{IN}} = 100\text{kHz}$, -20dBFS		-98	-90	dB
	$f_{\text{IN}} = 500\text{kHz}$, -2dBFS		-114		dB
	$f_{\text{IN}} = 500\text{kHz}$, -6dBFS		-110		dB
	$f_{\text{IN}} = 500\text{kHz}$, -20dBFS		-96		dB
Signal-to-noise and distortion (SINAD)	$f_{\text{IN}} = 10\text{kHz}$, -2dBFS		92		dB
	$f_{\text{IN}} = 10\text{kHz}$, -6dBFS		89		dB
	$f_{\text{IN}} = 10\text{kHz}$, -20dBFS		76		dB
	$f_{\text{IN}} = 100\text{kHz}$, -2dBFS		91		dB
	$f_{\text{IN}} = 100\text{kHz}$, -6dBFS		89		dB
	$f_{\text{IN}} = 100\text{kHz}$, -20dBFS	69	76		dB
	$f_{\text{IN}} = 500\text{kHz}$, -2dBFS		93		dB
	$f_{\text{IN}} = 500\text{kHz}$, -6dBFS		90		dB
	$f_{\text{IN}} = 500\text{kHz}$, -20dBFS		76		dB

ELECTRICAL CHARACTERISTICS (continued)

All specifications at –40°C to +85°C, AVDD = 5V, DVDD = IOVDD = 3V, fCLK = 40MHz, External VREF = +3V, VCM = 2.0V, FIFO disabled, and RBIAS = 37kΩ, unless otherwise noted.

PARAMETER	TEST CONDITIONS	MIN	TYP	MAX	UNIT
Spurious-free dynamic range (SFDR)	fIN = 10kHz, –2dBFS		104		dB
	fIN = 10kHz, –6dBFS		106		dB
	fIN = 10kHz, –20dBFS		99		dB
	fIN = 100kHz, –2dBFS		97		dB
	fIN = 100kHz, –6dBFS		103		dB
	fIN = 100kHz, –20dBFS	92	102		dB
	fIN = 500kHz, –2dBFS		120		dB
	fIN = 500kHz, –6dBFS		113		dB
	fIN = 500kHz, –20dBFS		99		dB
Intermodulation distortion (IMD)	f1 = 495kHz, –2dBFS f2 = 505kHz, –2dBFS		–98		dB
Aperture delay			4		ns
Digital Filter Characteristics					
Passband		0		$550 \left(\frac{f_{CLK}}{40MHz} \right)$	kHz
Passband ripple				± 0.0025	dB
Passband transition	–0.1dB attenuation		$575 \left(\frac{f_{CLK}}{40MHz} \right)$		kHz
	–3.0dB attenuation		$615 \left(\frac{f_{CLK}}{40MHz} \right)$		kHz
Stop band		$0.7 \left(\frac{f_{CLK}}{40MHz} \right)$		$39.3 \left(\frac{f_{CLK}}{40MHz} \right)$	MHz
Stop band attenuation		72			dB
Group delay			$20.8 \left(\frac{40MHz}{f_{CLK}} \right)$		μs
Settling time	To ±0.001%		$36.8 \left(\frac{40MHz}{f_{CLK}} \right)$		μs
Static Specifications					
Resolution			18		Bits
No missing codes		18			Bits
Input referred noise			1.5		LSB, rms
Integral nonlinearity	–2.0dBFS signal		3.5		LSB
Differential nonlinearity			±0.5		LSB
Offset error			0.05		%FSR
Offset error drift			1		ppmFSR/°C
Gain error			0.25		%
Gain error drift	Excluding reference drift		10		ppm/°C
Common-mode rejection	at DC		75		dB
Power-supply rejection	at DC		65		dB

ELECTRICAL CHARACTERISTICS (continued)

All specifications at -40°C to $+85^{\circ}\text{C}$, $\text{AVDD} = 5\text{V}$, $\text{DVDD} = \text{IOVDD} = 3\text{V}$, $f_{\text{CLK}} = 40\text{MHz}$, External $V_{\text{REF}} = +3\text{V}$, $V_{\text{CM}} = 2.0\text{V}$, FIFO disabled, and $\text{RBIAS} = 37\text{k}\Omega$, unless otherwise noted.

PARAMETER	TEST CONDITIONS	MIN	TYP	MAX	UNIT
Voltage Reference⁽¹⁾					
$V_{\text{REF}} = (\text{VREFP} - \text{VREFN})$		2.5	3.0	3.2	V
VREFP		3.75	4.0	4.25	V
VREFN		0.75	1.0	1.25	V
VMID		2.3	2.5	2.8	V
V_{REF} drift	Internal reference ($\overline{\text{REFEN}} = \text{low}$)		50		ppm/ $^{\circ}\text{C}$
Startup time	Internal reference ($\overline{\text{REFEN}} = \text{low}$)		15		ms
Clock Input					
Frequency (f_{CLK})		1	40	50	MHz
Duty Cycle	$f_{\text{CLK}} = 40\text{MHz}$	45		55	%
Digital Input/Output					
V_{IH}		0.7 IOVDD		IOVDD	V
V_{IL}		DGND		0.3 IOVDD	V
V_{OH}	$I_{\text{OH}} = 50\mu\text{A}$	0.8 IOVDD			V
V_{OL}	$I_{\text{OL}} = 50\mu\text{A}$			0.2 IOVDD	V
Input leakage	$\text{DGND} < V_{\text{DIGIN}} < \text{IOVDD}$			± 10	μA
Power-Supply Requirements					
AVDD		4.75		5.25	V
DVDD		2.7		3.3	V
IOVDD		2.7		5.25	V
AVDD current (I_{AVDD})	$\overline{\text{REFEN}} = \text{low}$		110	135	mA
	$\overline{\text{REFEN}} = \text{high}$		85	105	mA
DVDD current (I_{DVDD})			27	35	mA
IOVDD current (I_{IOVDD})	IOVDD = 3V		3	5	mA
Power dissipation	AVDD = 5V, DVDD = 3V, IOVDD = 3V, $\overline{\text{REFEN}} = \text{high}$		515	645	mW
	$\overline{\text{PD}} = \text{low}$, CLK disabled		5		mW
Temperature Range					
Specified		-40		+85	$^{\circ}\text{C}$
Operating		-40		+105	$^{\circ}\text{C}$
Storage		-60		+150	$^{\circ}\text{C}$
Thermal Resistance, θ_{JA}	PowerPAD soldered to PCB with 2oz. trace and copper pad.		25		$^{\circ}\text{C}/\text{W}$
		θ_{JC}	0.5		$^{\circ}\text{C}/\text{W}$

(1) The specification limits for V_{REF} , VREFP, VREFN, and VMID apply when using the internal or an external reference. The internal reference voltages are bounded by the limits shown. When using an external reference, the limits indicate the allowable voltages that can be applied to the reference pins.

DEFINITIONS

Absolute Input Voltage

Absolute input voltage, given in volts, is the voltage of each analog input (AINN or AINP) with respect to AGND.

Aperture Delay

Aperture delay is the delay between the rising edge of CLK and the sampling of the input signal.

Common-Mode Input Voltage

Common-mode input voltage (V_{CM}) is the average voltage of the analog inputs:

$$\frac{(AINP + AINN)}{2}$$

Differential Input Voltage

Differential input voltage (V_{IN}) is the voltage difference between the analog inputs: (AINP–AINN).

Differential Nonlinearity (DNL)

DNL, given in least-significant bits (LSB) of the output code, is the maximum deviation of the output code step sizes from the ideal value of 1LSB.

Full-Scale Range (FSR)

FSR is the difference between the maximum and minimum measurable input signals. For the ADS1625,
 $FSR = 2 \times 1.467V_{REF}$.

Gain Error

Gain error, given in %, is the error of the full-scale input signal with respect to the ideal value.

Gain Error Drift

Gain error drift, given in ppm/°C, is the drift over temperature of the gain error. The gain error is specified as the larger of the drift from ambient ($T_A = 25^\circ\text{C}$) to the minimum or maximum operating temperatures.

Integral Nonlinearity (INL)

INL, given in least significant bits (LSB) of the output code, is the maximum deviation of the output codes from a best-fit line.

Intermodulation Distortion (IMD)

IMD, given in dB, is measured while applying two input signals of the same magnitude, but with slightly different frequencies. It is calculated as the difference between the rms amplitude of the input signal to the rms amplitude of the peak spurious signal.

Offset Error

Offset Error, given in % of FSR, is the output reading when the differential input is zero.

Offset Error Drift

Offset error drift, given in ppm of FSR/°C, is the drift over temperature of the offset error. The offset error is specified as the larger of the drift from ambient ($T_A = 25^\circ\text{C}$) to the minimum or maximum operating temperatures.

Signal-to-Noise Ratio (SNR)

SNR, given in dB, is the ratio of the rms value of the input signal to the sum of all the frequency components below $f_{CLK}/2$ (the Nyquist frequency) excluding the first six harmonics of the input signal and the dc component.

Signal-to-Noise and Distortion (SINAD)

SINAD, given in dB, is the ratio of the rms value of the input signal to the sum of all the frequency components below $f_{CLK}/2$ (the Nyquist frequency) including the harmonics of the input signal but excluding the dc component.

Spurious Free Dynamic Range (SFDR)

SFDR, given in dB, is the difference between the rms amplitude of the input signal to the rms amplitude of the peak spurious signal.

Total Harmonic Distortion (THD)

THD, given in dB, is the ratio of the sum of the rms value of the first six harmonics of the input signal to the rms value of the input signal.

PIN ASSIGNMENTS

TQFP PACKAGE
(TOP VIEW)

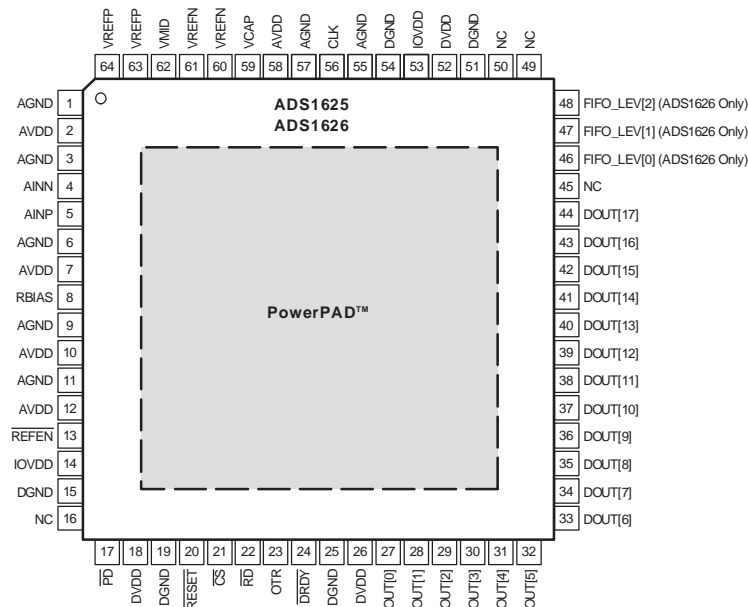

Terminal Functions

NAME	TERMINAL NO.	TYPE	DESCRIPTION
AGND	1, 3, 6, 9, 11, 55, 57	Analog	Analog ground
AVDD	2, 7, 10, 12, 58	Analog	Analog supply
AINN	4	Analog input	Negative analog input
AINP	5	Analog input	Positive analog input
RBIAS	8	Analog	Terminal for external analog bias setting resistor
REFEN	13	Digital input: active low	Internal reference enable. Internal pull-down resistor of 170kΩ to DGND.
NC	16, 45, 49, 50		Must be left unconnected
PD	17	Digital input: active low	Power down all circuitry. Internal pull-up resistor of 170kΩ to DGND.
DVDD	18, 26, 52	Digital	Digital supply
DGND	15, 19, 25, 51, 54	Digital	Digital ground
RESET	20	Digital input: active low	Reset digital filter
CS	21	Digital input: active low	Chip select
RD	22	Digital input: active low	Read enable
OTR	23	Digital output	Active when analog inputs are out of range
DRDY	24	Digital output: active low	Data ready on falling edge
DOUT [17:0]	27–44	Digital output	Data output. DOUT[17] is the MSB and DOUT[0] is the LSB.
FIFO_LEV[2:0]	46–48	Digital input	FIFO level (for the ADS1626 only). FIFO_LEV[2] is MSB. NOTE: These terminals must be left unconnected on the ADS1625.
IOVDD	14, 53	Digital	Digital I/O supply
CLK	56	Digital input	Clock input
VCAP	59	Analog	Terminal for external bypass capacitor connection to internal bias voltage
VREFN	60, 61	Analog	Negative reference voltage
VMID	62	Analog	Midpoint voltage
VREFP	63, 64	Analog	Positive reference voltage

PARAMETER MEASUREMENT INFORMATION

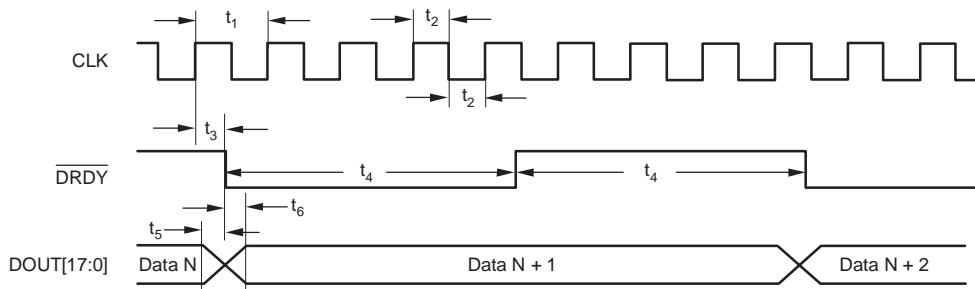

NOTE: \overline{CS} and \overline{RD} tied low.

Figure 1. Data Retrieval Timing (ADS1625, ADS1626 with FIFO Disabled)

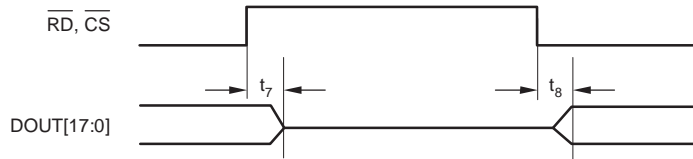
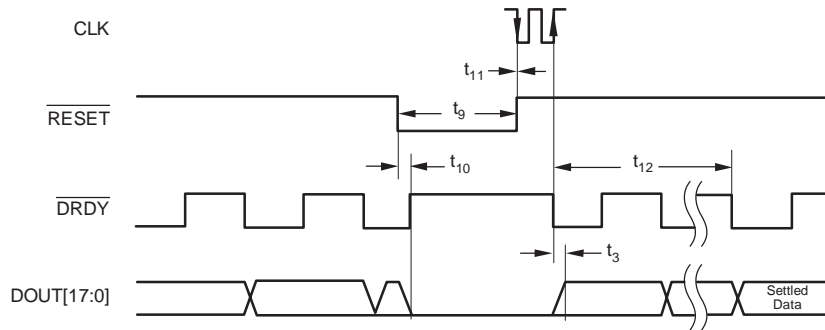

Figure 2. DOUT Inactive/Active Timing (ADS1625, ADS1626 with FIFO Disabled)

TIMING REQUIREMENTS FOR FIGURE 1 AND FIGURE 2

SYMBOL	DESCRIPTION	MIN	TYP	MAX	UNIT
t_1	CLK period ($1/f_{CLK}$)	20	25	1000	ns
$1/t_1$	f_{CLK}	1	40	50	MHz
t_2	CLK pulse width, high or low	10			ns
t_3	Rising edge of CLK to \overline{DRDY} low		10		ns
t_4	\overline{DRDY} pulse width high or low		$16 t_1$		ns
t_5	Falling edge of \overline{DRDY} to data invalid			10	ns
t_6	Falling edge of \overline{DRDY} to data valid			15	ns
t_7	Rising edge of \overline{RD} and/or \overline{CS} inactive (high) to DOUT high impedance			15	ns
t_8	Falling edge of \overline{RD} and/or \overline{CS} active (low) to DOUT active.			15	ns

NOTE: DOUT[17:0] and \overline{DRDY} load = 10pF.



NOTE: \overline{CS} and \overline{RD} tied low.

Figure 3. Reset Timing (ADS1625, ADS1626 with FIFO Disabled)

TIMING REQUIREMENTS FOR FIGURE 3

SYMBOL	DESCRIPTION	MIN	TYP	MAX	UNIT
t ₃	Rising edge of CLK to \overline{DRDY} low		10		ns
t ₉	\overline{RESET} pulse width	50			ns
t ₁₀	Delay from \overline{RESET} active (low) to \overline{DRDY} forced high and DOUT forced low		9		ns
t ₁₁	\overline{RESET} rising edge to falling edge of CLK	-5		10	ns
t ₁₂	Delay from DOUT active to valid DOUT (settling to 0.001%)		46		\overline{DRDY} Cycles

NOTE: DOUT[17:0] and \overline{DRDY} load = 10pF.

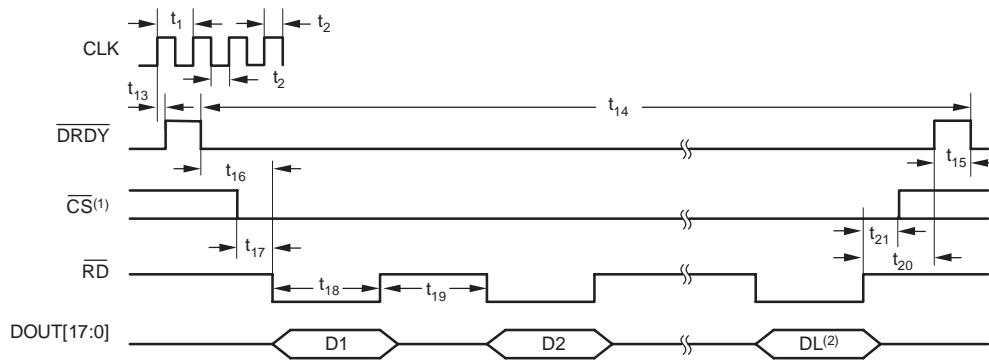

- (1) \overline{CS} may be tied low.
(2) The number of data readings (DL) is set by the FIFO level.

Figure 4. Data Retrieval Timing (ADS1626 with FIFO Enabled)

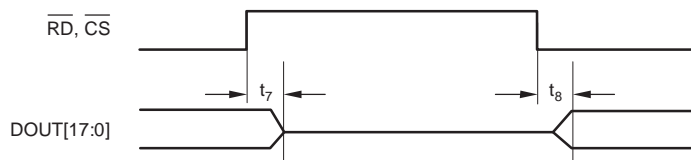

Figure 5. DOUT Inactive/Active Timing (ADS1626 with FIFO Enabled)

TIMING REQUIREMENTS FOR FIGURE 4 AND FIGURE 5

SYMBOL	DESCRIPTION	MIN	TYP	MAX	UNIT
t ₁	CLK period (1/f _{CLK})	20	25	1000	ns
t ₂	CLK pulse width, high or low	10			ns
t ₇	Rising edge of \overline{RD} and/or \overline{CS} inactive (high) to DOUT high impedance		7	15	ns
t ₈	Falling edge of \overline{RD} and/or \overline{CS} active (low) to DOUT active.		7	15	ns
t ₁₃	Rising edge of CLK to \overline{DRDY} high		12		ns
t ₁₄	\overline{DRDY} period	32 × FIFO Level ⁽¹⁾			CLK Cycles
t ₁₅	\overline{DRDY} positive pulse width		1		CLK Cycles
t ₁₆	\overline{RD} high hold time after \overline{DRDY} goes low	0			ns
t ₁₇	\overline{CS} low before \overline{RD} goes low	0			ns
t ₁₈	\overline{RD} negative pulse width	10			ns
t ₁₉	\overline{RD} positive pulse width	10			ns
t ₂₀	\overline{RD} high before \overline{DRDY} toggles	2			CLK Cycles
t ₂₁	\overline{RD} high before \overline{CS} goes high	0			ns

NOTE: DOUT[17:0] and \overline{DRDY} load = 10pF.

(1) See FIFO section for more details.

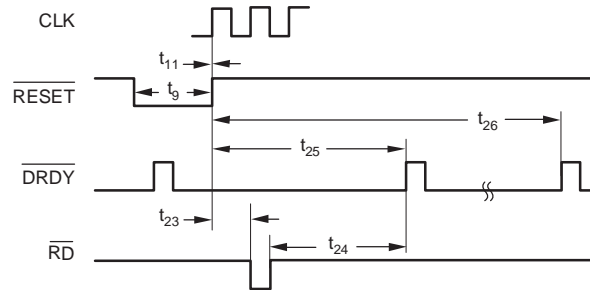

Figure 6. Reset Timing (ADS1626 with FIFO Enabled)

TIMING REQUIREMENTS FOR FIGURE 6

SYMBOL	DESCRIPTION	MIN	TYP	MAX	UNIT
t ₉	$\overline{\text{RESET}}$ pulse width	50			ns
t ₁₁	$\overline{\text{RESET}}$ rising edge to falling edge of CLK	-5		10	ns
t ₂₃	$\overline{\text{RD}}$ pulse low after $\overline{\text{RESET}}$ goes high	32			CLK Cycles
t ₂₄	$\overline{\text{RD}}$ pulse high before first $\overline{\text{DRDY}}$ pulse after $\overline{\text{RESET}}$ goes high	32			CLK Cycles
t ₂₅	$\overline{\text{DRDY}}$ low after $\overline{\text{RESET}}$ goes low	32 × (FIFO level + 1)			CLK Cycles
t ₂₆	Delay from $\overline{\text{RESET}}$ high to valid DOUT (settling to 0.001%)		See Table 4		$\overline{\text{DRDY}}$ Cycles

TYPICAL CHARACTERISTICS

All specifications at $T_A = 25^\circ\text{C}$, $AVDD = 5\text{V}$, $DVDD = IOVDD = 3\text{V}$, $f_{\text{CLK}} = 40\text{MHz}$, External $V_{\text{REF}} = +3\text{V}$, $V_{\text{CM}} = 2.0\text{V}$, and $R_{\text{BIAS}} = 37\text{k}\Omega$, unless otherwise noted.

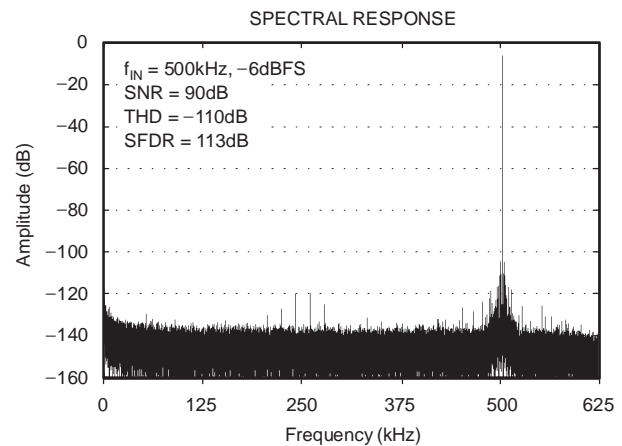
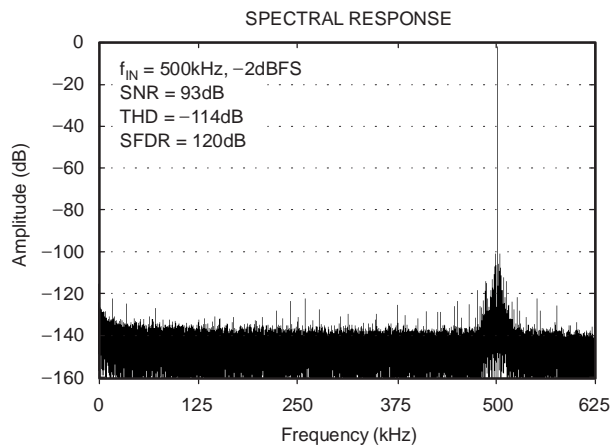
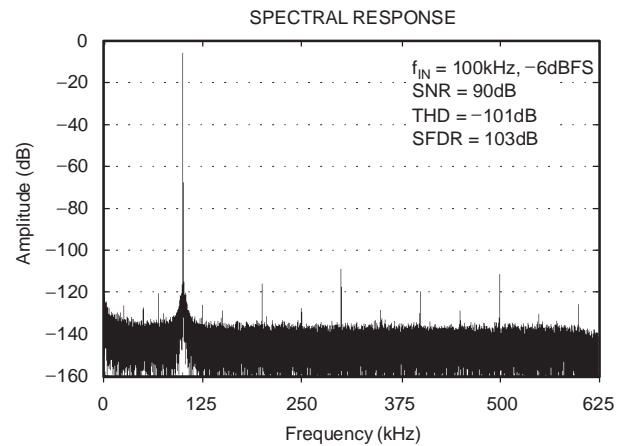
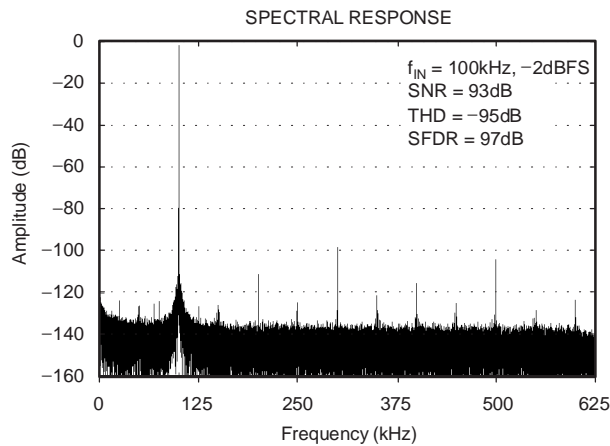
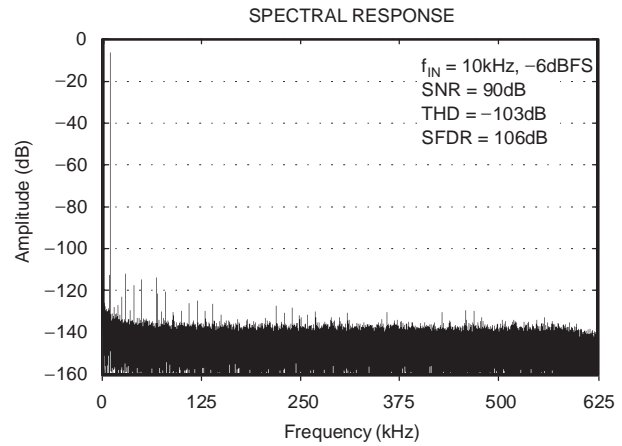
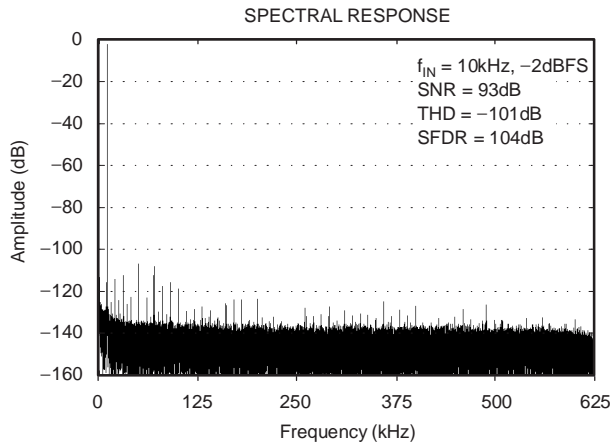

TYPICAL CHARACTERISTICS (continued)

All specifications at $T_A = 25^\circ\text{C}$, $AV_{DD} = 5\text{V}$, $DV_{DD} = IO_{VDD} = 3\text{V}$, $f_{CLK} = 40\text{MHz}$, External $V_{REF} = +3\text{V}$, $V_{CM} = 2.0\text{V}$, and $R_{BIAS} = 37\text{k}\Omega$, unless otherwise noted.

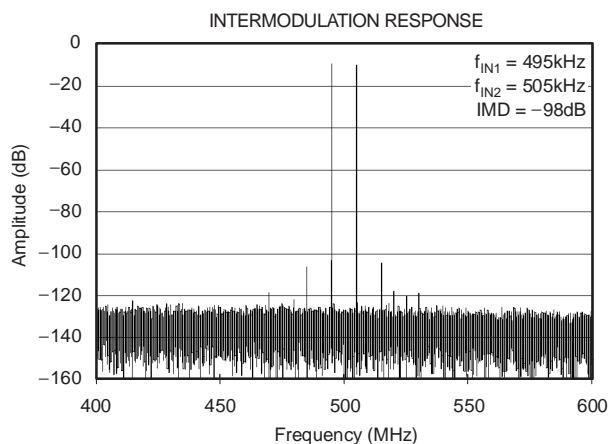
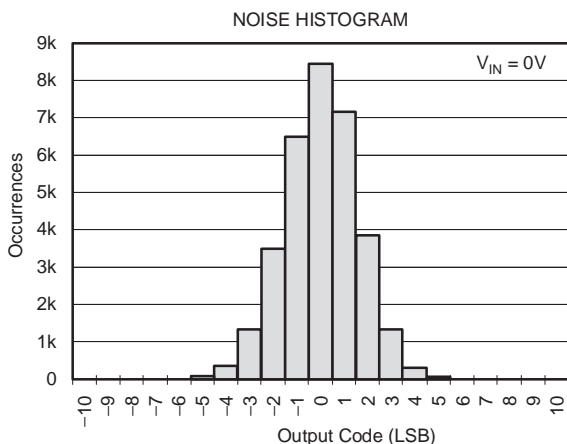

SIGNAL-TO-NOISE RATIO, TOTAL HARMONIC DISTORTION,
AND SPURIOUS-FREE DYNAMIC RANGE
vs INPUT SIGNAL AMPLITUDE

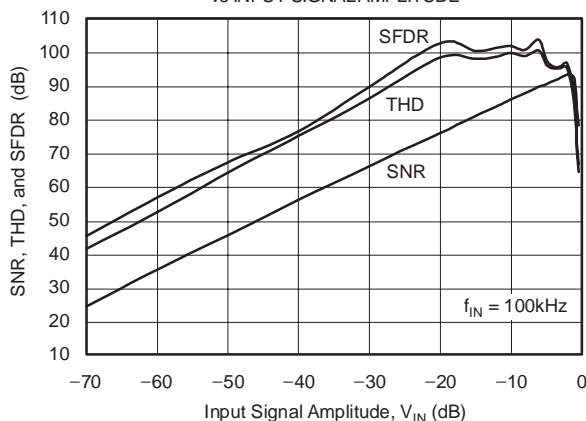

SIGNAL-TO-NOISE RATIO
vs INPUT FREQUENCY

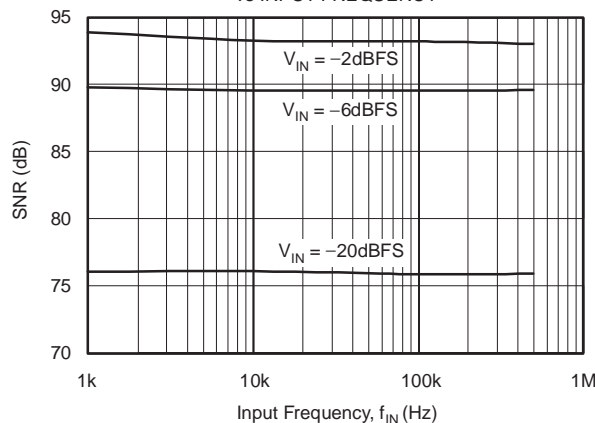

TOTAL HARMONIC DISTORTION
vs INPUT FREQUENCY

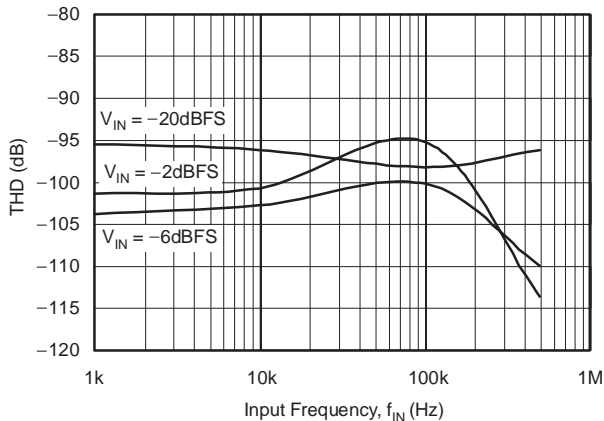

SPURIOUS-FREE DYNAMIC RANGE
vs INPUT FREQUENCY

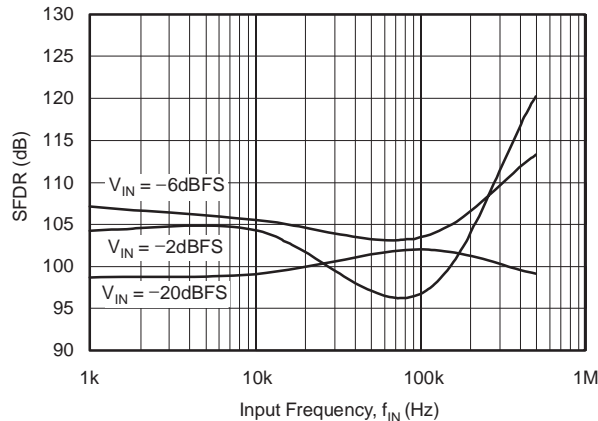

TYPICAL CHARACTERISTICS (continued)

All specifications at $T_A = 25^\circ\text{C}$, $AV_{DD} = 5\text{V}$, $DV_{DD} = IOV_{DD} = 3\text{V}$, $f_{CLK} = 40\text{MHz}$, External $V_{REF} = +3\text{V}$, $V_{CM} = 2.0\text{V}$, and $R_{BIAS} = 37\text{k}\Omega$, unless otherwise noted.

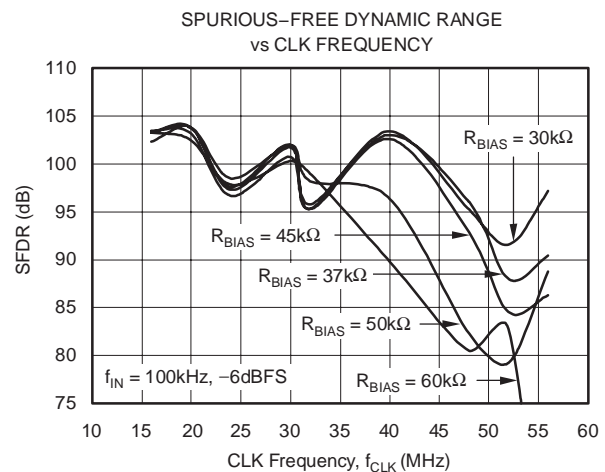
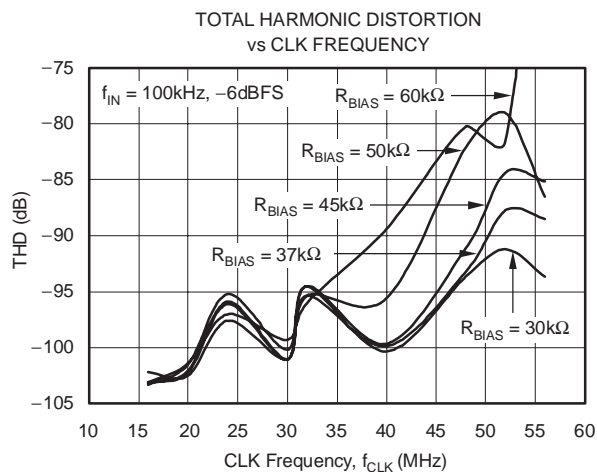
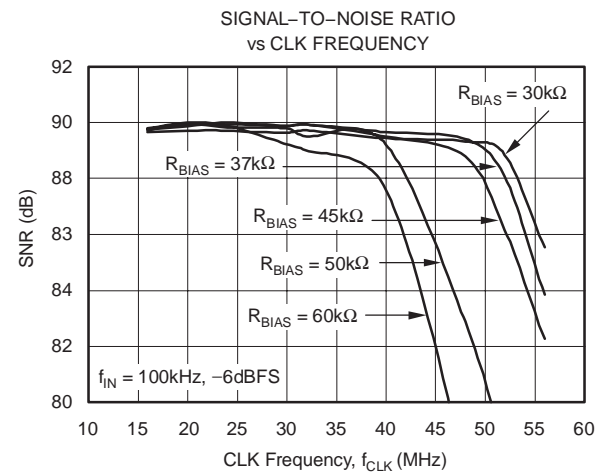
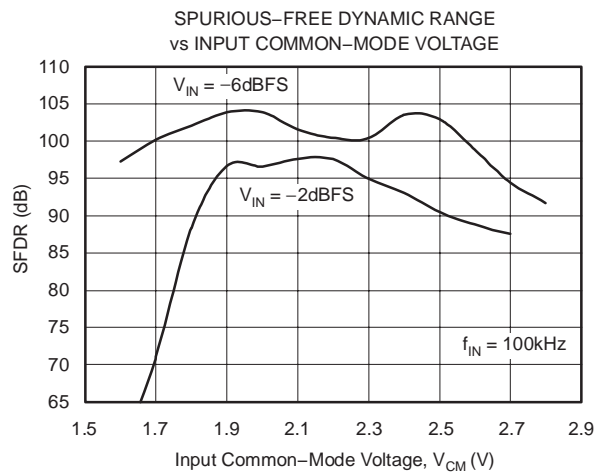
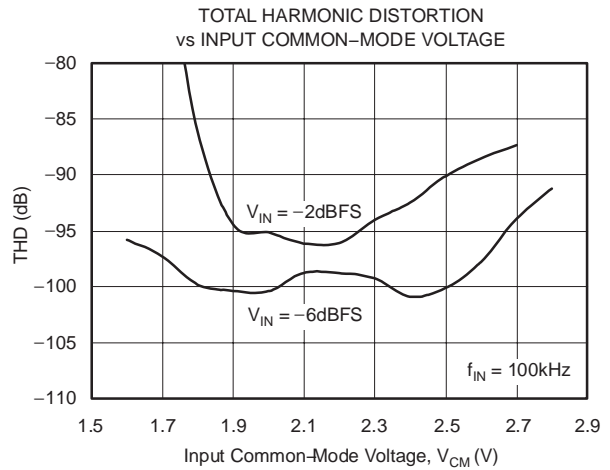
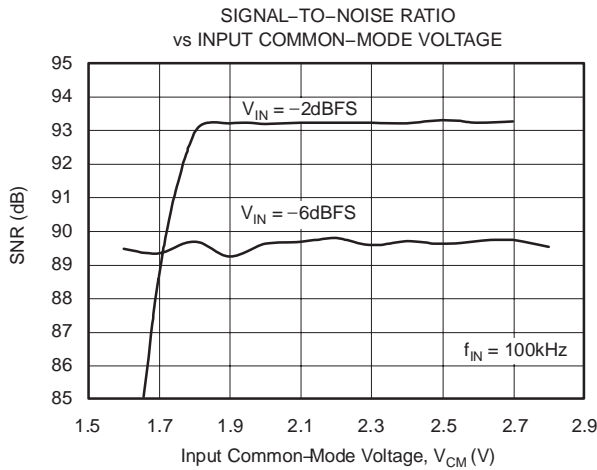

TYPICAL CHARACTERISTICS (continued)

All specifications at $T_A = 25^\circ\text{C}$, $AVDD = 5\text{V}$, $DVDD = IOVDD = 3\text{V}$, $f_{\text{CLK}} = 40\text{MHz}$, External $V_{\text{REF}} = +3\text{V}$, $V_{\text{CM}} = 2.0\text{V}$, and $R_{\text{BIAS}} = 37\text{k}\Omega$, unless otherwise noted.

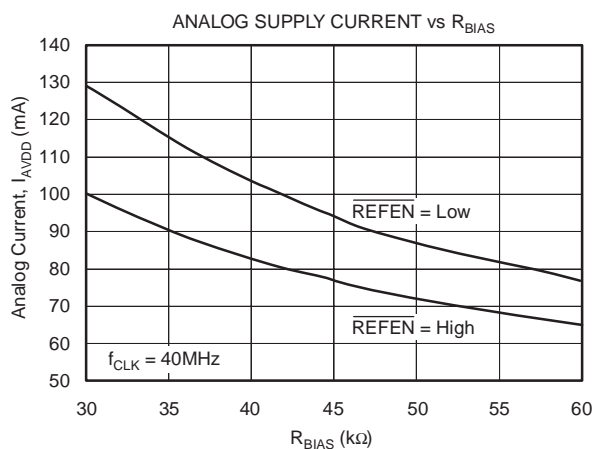
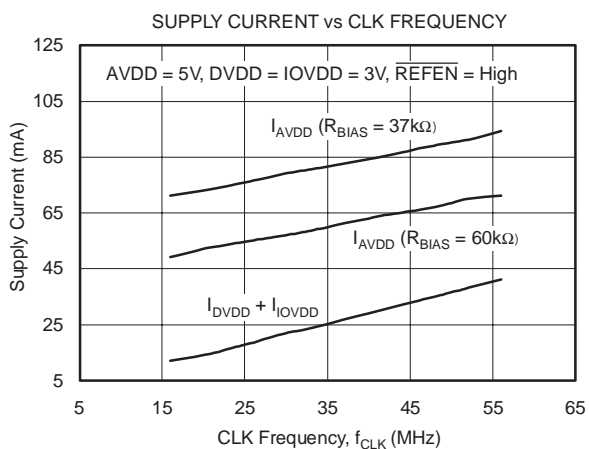
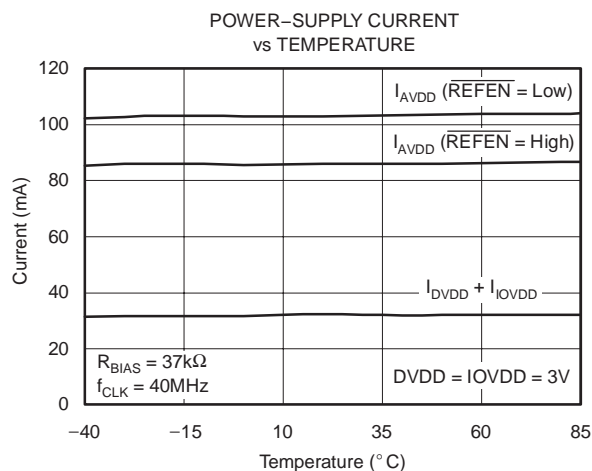
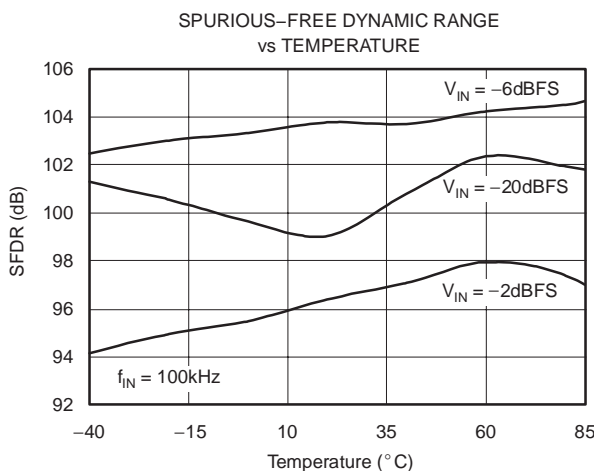
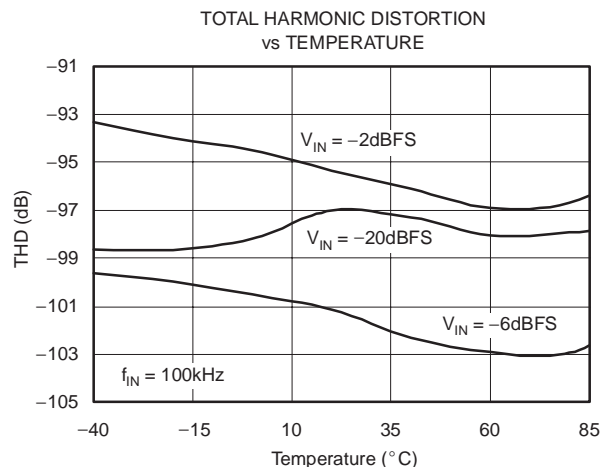
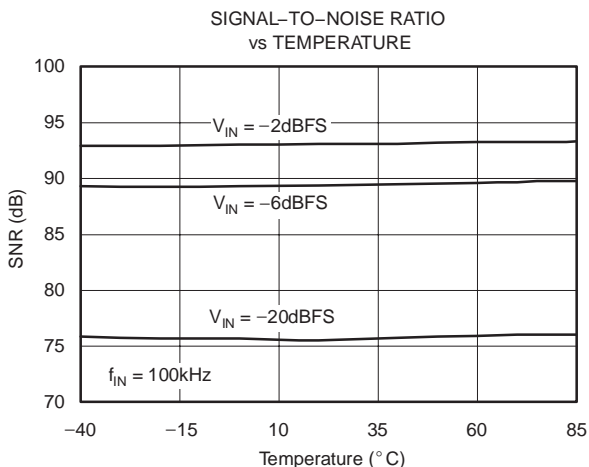

TYPICAL CHARACTERISTICS (continued)

All specifications at $T_A = 25^\circ\text{C}$, $AV_{DD} = 5\text{V}$, $DV_{DD} = IOV_{DD} = 3\text{V}$, $f_{CLK} = 40\text{MHz}$, External $V_{REF} = +3\text{V}$, $V_{CM} = 2.0\text{V}$, and $R_{BIAS} = 37\text{k}\Omega$, unless otherwise noted.

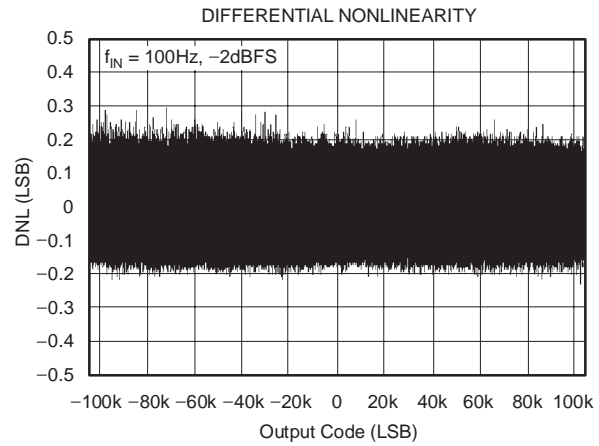
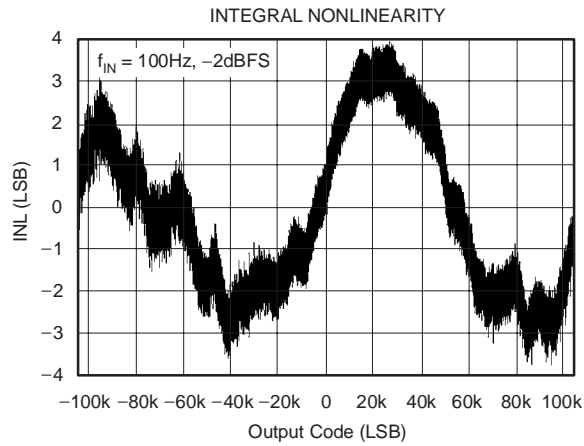

OVERVIEW

The ADS1625 and ADS1626 are high-performance delta-sigma ADCs with a default oversampling ratio of 32. The modulator uses an inherently stable 2-1-1 pipelined delta-sigma modulator architecture incorporating proprietary circuitry that allows for very linear high-speed operation. The modulator samples the input signal at 40MSPS (when $f_{CLK} = 40\text{MHz}$). A low-ripple, linear-phase digital filter decimates the modulator output to provide data output word rates of 1.25MSPS with a signal passband out to 615kHz.

Conceptually, the modulator and digital filter measure the differential input signal, $V_{IN} = (A_{INP} - A_{INN})$, against the scaled differential reference, $V_{REF} = (V_{REFP} - V_{REFN})$, as shown in Figure 7. The voltage reference can either be generated internally or supplied externally. An 18-bit parallel data bus, designed for direct connection to DSPs, outputs the data. A separate power supply for the I/O allows flexibility for interfacing to different logic families. Out-of-range conditions are indicated with a dedicated digital output pin. Analog power dissipation is controlled using an external resistor. This allows reduced dissipation when operating at slower speeds. When not in use, power consumption can be dramatically reduced using the \overline{PD} pin.

The ADS1626 incorporates an adjustable FIFO for the output data. The level of the FIFO is set by the FIFO_LEV[2:0] pins. Other than the FIFO, the ADS1625 and ADS1626 are identical, and together are referred to as the ADS1625/6.

ANALOG INPUTS (A_{INP}, A_{INN})

The ADS1625/6 measures the differential signal, $V_{IN} = (A_{INP} - A_{INN})$, against the differential reference, $V_{REF} = (V_{REFP} - V_{REFN})$. The reference is scaled internally so that the full-scale differential input voltage is $1.467V_{REF}$. That is, the most positive measurable differential input is $1.467V_{REF}$, which produces the most

positive digital output code of 7FFFh. Likewise, the most negative measurable differential input is $-1.467V_{REF}$, which produces the most negative digital output code of 8000h.

The ADS1625/6 supports a very wide range of input signals. For $V_{REF} = 3\text{V}$, the full scale input voltages are $\pm 4.4\text{V}$. Having such a wide input range makes out-of-range signals unlikely. However, should an out-of-range signal occur, digital output OTR will go high.

To achieve the highest analog performance, it is recommended that the inputs be limited to $\pm 1.165V_{REF}$ (-2dBFS). For $V_{REF} = 3\text{V}$, the corresponding recommended input range is $\pm 3.78\text{V}$.

The analog inputs must be driven with a differential signal to achieve optimum performance. The recommended common-mode voltage of the input signal, $V_{CM} = \frac{A_{INP} + A_{INN}}{2}$, is 2.0V. For signals larger than -2dBFS , the input common-mode voltage needs to be raised in order to meet the absolute input voltage specifications. The Typical Characteristics show how performance varies with input common-mode voltage.

In addition to the differential and common-mode input voltages, the absolute input voltage is also important. This is the voltage on either input (A_{INP} or A_{INN}) with respect to AGND. The range for this voltage is:

$$-0.1\text{V} < (A_{INN} \text{ or } A_{INP}) < 4.6\text{V}.$$

If either input is taken below -0.1V , ESD protection diodes on the inputs will turn on. Exceeding 4.6V on either input will result in degradation in the linearity performance. ESD protection diodes will also turn on if the inputs are taken above AVDD (+5V).

For signals below -2dBFS , the recommended absolute input voltage is:

$$0.1\text{V} < (A_{INN} \text{ or } A_{INP}) < 4.2\text{V}$$

Keeping the inputs within this range provides for optimum performance.

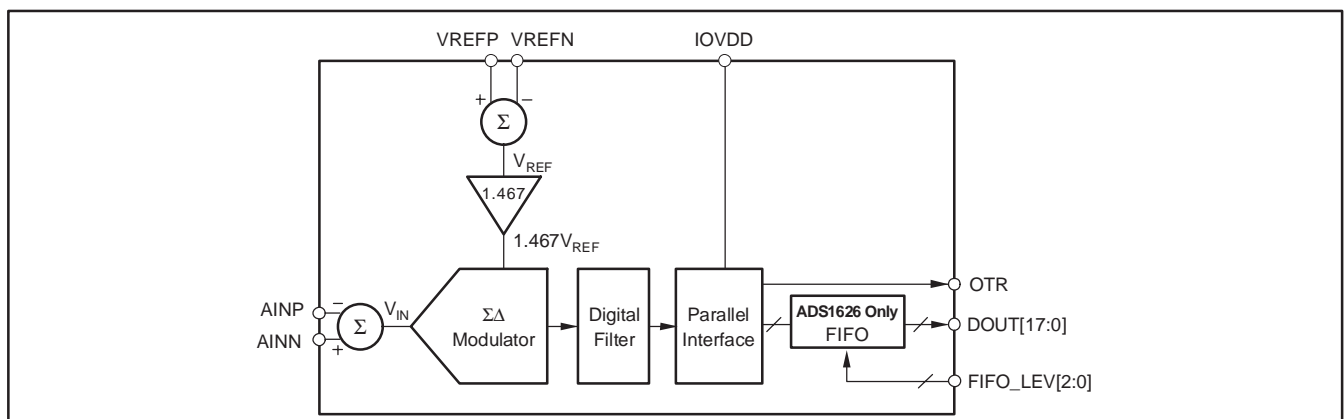

Figure 7. Conceptual Block Diagram

INPUT CIRCUITRY

The ADS1625/6 uses switched-capacitor circuitry to measure the input voltage. Internal capacitors are charged by the inputs and then discharged internally with this cycle repeating at the frequency of CLK. Figure 8 shows a conceptual diagram of these circuits. Switches S2 represent the net effect of the modulator circuitry in discharging the sampling capacitors, the actual implementation is different. The timing for switches S1 and S2 is shown in Figure 9.

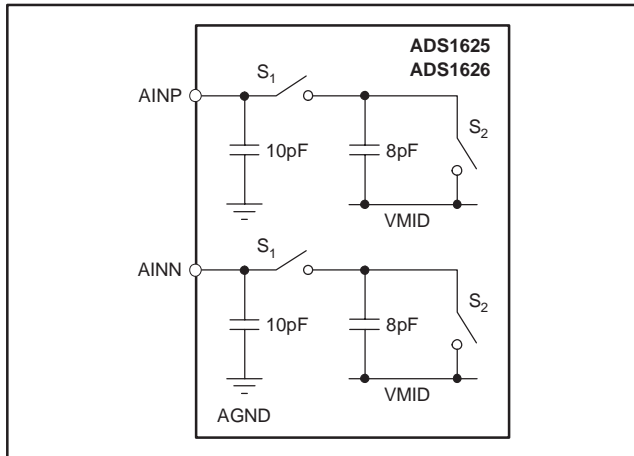

Figure 8. Conceptual Diagram of Internal Circuitry Connected to the Analog Inputs

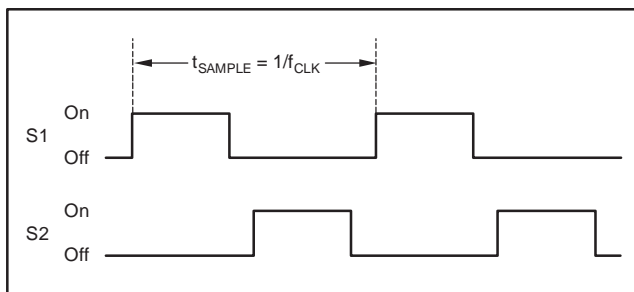

Figure 9. Timing for the Switches in Figure 2

DRIVING THE INPUTS

The external circuits driving the ADS1625/6 inputs must be able to handle the load presented by the switching capacitors within the ADS1625/6. Input switches S1 in Figure 9 are closed approximately one-half of the sampling period, t_{sample} , allowing only $\approx 12ns$ for the internal capacitors to be charged by the inputs, when $f_{CLK} = 40MHz$.

Figure 10 and Figure 11 show the recommended circuits when using single-ended or differential op amps, respectively. The analog inputs must be driven differentially to achieve optimum performance. The external capacitors, between the inputs and from each

input to AGND, improve linearity and should be placed as close to the pins as possible. Place the drivers close to the inputs and use good capacitor bypass techniques on their supplies; usually a smaller high-quality ceramic capacitor in parallel with a larger capacitor. Keep the resistances used in the driver circuits low—thermal noise in the driver circuits degrades the overall noise performance. When the signal can be ac-coupled to the ADS1625/6 inputs, a simple RC filter can set the input common-mode voltage. The ADS1625/6 is a high-speed, high-performance ADC. Special care must be taken when selecting the test equipment and setup used with this device. Pay particular attention to the signal sources to ensure they do not limit performance when measuring the ADS1625/6.

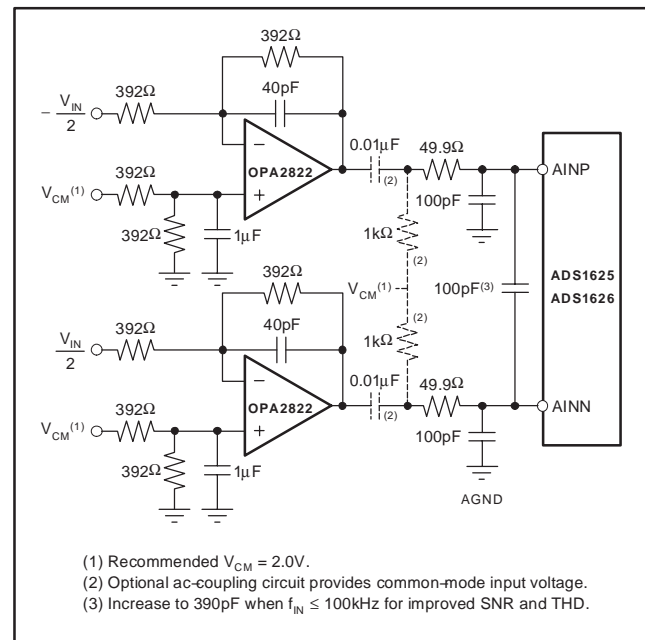

- (1) Recommended $V_{CM} = 2.0V$.
- (2) Optional ac-coupling circuit provides common-mode input voltage.
- (3) Increase to 390pF when $f_{IN} \leq 100kHz$ for improved SNR and THD.

Figure 10. Recommended Driver Circuit Using the OPA2822

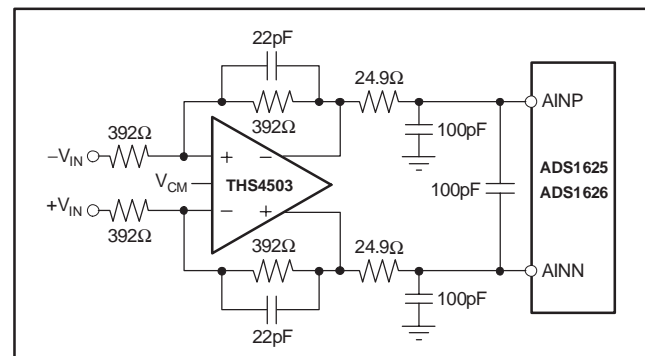

Figure 11. Recommended Driver Circuits Using the THS4503 Differential Amplifier

REFERENCE INPUTS (VREFN, VREFP, VMID)

The ADS1625 can operate from an internal or external voltage reference. In either case, reference voltage V_{REF} is set by the differential voltage between VREFN and VREFP: $V_{REF} = (V_{REFP} - V_{REFN})$. VREFP and VREFN each use two pins, which should be shorted together. VMID equals approximately 2.5V and is used by the modulator. VCAP connects to an internal node, and must also be bypassed with an external capacitor. For the best analog performance, it is recommended that an external reference voltage (V_{REF}) of 3.0V be used.

INTERNAL REFERENCE ($\overline{REFEN} = \text{LOW}$)

To use the internal reference, set the \overline{REFEN} pin low. This activates the internal circuitry that generates the reference voltages. The internal reference voltages are applied to the pins. Good bypassing of the reference pins is critical to achieve optimum performance and is done by placing the bypass capacitors as close to the pins as possible. Figure 12 shows the recommended bypass capacitor values. Use high quality ceramic capacitors for the smaller values. Avoid loading the internal reference with external circuitry. If the ADS1625/6 internal reference is to be used by other circuitry, buffer the reference voltages to prevent directly loading the reference pins.

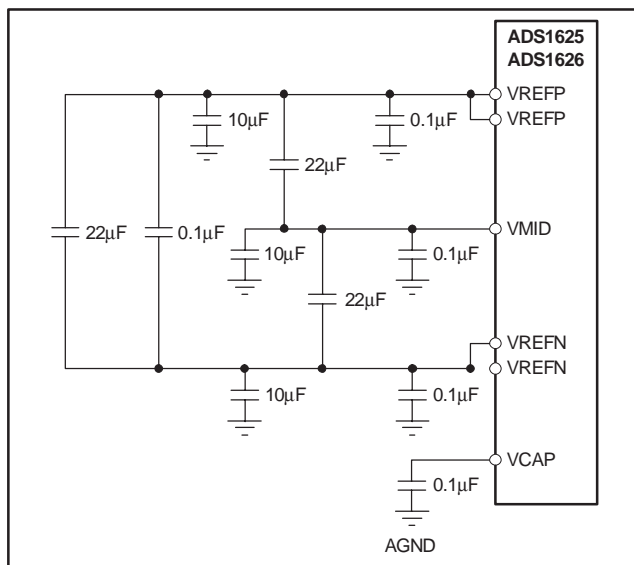

Figure 12. Reference Bypassing When Using the Internal Reference

EXTERNAL REFERENCE ($\overline{REFEN} = \text{HIGH}$)

To use an external reference, set the \overline{REFEN} pin high. This deactivates the internal generators for VREFP, VREFN and VMID, and saves approximately 25mA of current on the analog supply (AVDD). The voltages applied to these pins must be within the values specified in the Electrical Characteristics table. Typically $V_{REFP} = 4V$, $VMID = 2.5V$

and $V_{REFN} = 1V$. The external circuitry must be capable of providing both a dc and a transient current. Figure 13 shows a simplified diagram of the internal circuitry of the reference when the internal reference is disabled. As with the input circuitry, switches S1 and S2 open and close as shown in Figure 9.

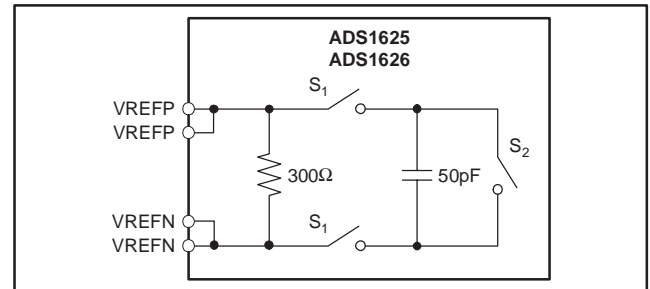

Figure 13. Conceptual Internal Circuitry for the Reference When $\overline{REFEN} = \text{High}$

Figure 14 shows the recommended circuitry for driving these reference inputs. Keep the resistances used in the buffer circuits low to prevent excessive thermal noise from degrading performance. Layout of these circuits is critical; make sure to follow good high-speed layout practices. Place the buffers, and especially the bypass capacitors, as close to the pins as possible. VCAP is unaffected by the setting on \overline{REFEN} and must be bypassed when using the internal or an external reference.

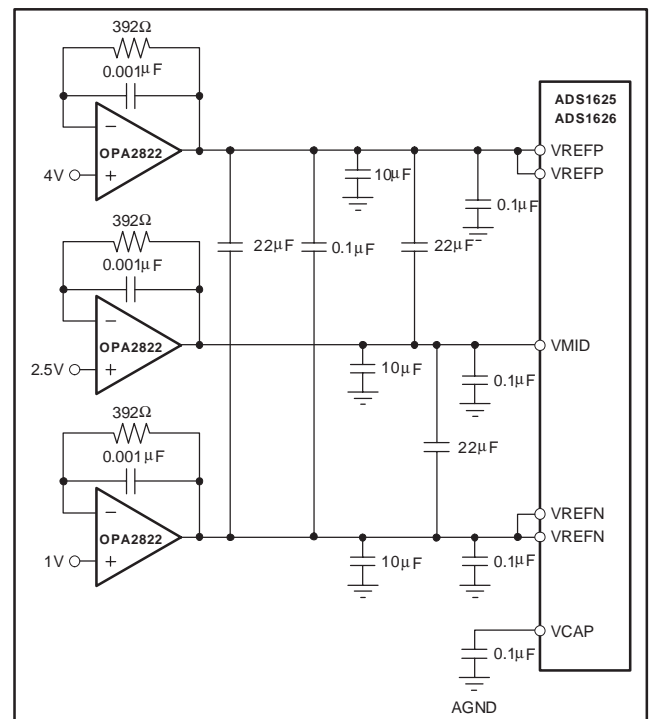

Figure 14. Recommended Buffer Circuit When Using an External Reference

CLOCK INPUT (CLK)

The ADS1625/6 requires an external clock signal to be applied to the CLK input pin. The sampling of the modulator is controlled by this clock signal. As with any high-speed data converter, a high quality clock is essential for optimum performance. Crystal clock oscillators are the recommended CLK source; other sources, such as frequency synthesizers, are usually not adequate. Make sure to avoid excess ringing on the CLK input; keeping the trace as short as possible will help.

Measuring high-frequency, large-amplitude signals requires tight control of clock jitter. The uncertainty during sampling of the input from clock jitter limits the maximum achievable SNR. This effect becomes more pronounced with higher frequency and larger magnitude inputs. Fortunately, the ADS1625/6 oversampling topology reduces clock jitter sensitivity over that of Nyquist rate converters like pipeline and successive approximation converters by a factor of $\sqrt{32}$.

In order to not limit the ADS1625/6 SNR performance, keep the jitter on the clock source below the values shown in Table 1. When measuring lower frequency and lower amplitude inputs, more CLK jitter can be tolerated. In determining the allowable clock source jitter, select the worst-case input (highest frequency, largest amplitude) that will be seen in the application.

Table 1. Maximum Allowable Clock Source Jitter for Different Input Signal Frequencies and Amplitude

INPUT SIGNAL		MAXIMUM ALLOWABLE CLOCK SOURCE JITTER (RMS)
MAXIMUM FREQUENCY	MAXIMUM AMPLITUDE	
500kHz	-2dB	7ps
500kHz	-20dB	50ps
100kHz	-2dB	35ps
100kHz	-20dB	285ps

DATA FORMAT

The 18-bit output data is in binary two's complement format, as shown in Table 2. Under normal operation, the output codes range between 200A8h to 1FF57h. Signals less than $-1.467V_{REF}$ will clip at 200A8h and likewise, signals greater than $1.467V_{REF}$ will clip at 1FF57h. For large step changes on the inputs, the output clips at the positive full-scale value of 1FFFFh (positive transients) or the negative full-scale value of 20000h (negative transients).

Table 2. Output Code Versus Input Signal

INPUT SIGNAL (INP – INN)	IDEAL OUTPUT CODE(1)	OTR
$\geq +1.467V_{REF}$ ($> 0dB$)(2)	1FFFFh	1
$\geq +1.467V_{REF}$ (0dB)	1FF57h	0
$\frac{+1.467V_{REF}}{2^{17} - 1}$	00001h	0
0	00000h	0
$\frac{-1.467V_{REF}}{2^{17} - 1}$	3FFFFh	0
$\leq -1.467V_{REF} \left(\frac{2^{17}}{2^{17} - 1} \right)$	200A8h	0
$\leq -1.467V_{REF} \left(\frac{2^{17}}{2^{17} - 1} \right)$ (2)	20000h	1

(1) Excludes effects of noise, INL, offset and gain errors.

(2) Large step inputs.

OUT-OF-RANGE INDICATION (OTR)

If the output code on DOUT[17:0] exceeds the positive or negative full-scale, the out-of-range digital output OTR will go high on the falling edge of \overline{DRDY} . When the output code returns within the full-scale range, OTR returns low on the falling edge of \overline{DRDY} .

DATA RETRIEVAL

Data retrieval is controlled through a simple parallel interface. The falling edge of the \overline{DRDY} output indicates new data are available. To activate the output bus, both \overline{CS} and \overline{RD} must be low, as shown in Table 3. On the ADS1625, both of these signals can be tied low. On the ADS1626 with FIFO enabled, only \overline{CS} can be tied low because \overline{RD} must toggle to operate the FIFO. See the FIFO section for more details. Make sure the DOUT bus does not drive heavy loads ($> 20pF$), as this will degrade performance. Use an external buffer when driving an edge connector or cables.

Table 3. Truth Table for \overline{CS} and \overline{RD}

\overline{CS}	\overline{RD}	DOUT[17:0]
0	0	Active
0	1	High impedance
1	0	High impedance
1	1	High impedance

RESETTING THE ADS1625

The ADS1625 and ADS1626 with FIFO disabled are asynchronously reset when the $\overline{\text{RESET}}$ pin is taken low. During reset, all of the digital circuits are cleared, $\text{DOUT}[17:0]$ are forced low, and $\overline{\text{DRDY}}$ forced high. It is recommended that the $\overline{\text{RESET}}$ pin be released on the falling edge of CLK. Afterwards, $\overline{\text{DRDY}}$ goes low on the second rising edge of CLK. Allow 46 $\overline{\text{DRDY}}$ cycles for the digital filter to settle before retrieving data. See Figure 3 for the timing specifications.

Reset can be used to synchronize multiple ADS1625s. All devices to be synchronized must use a common CLK input. With the CLK inputs running, pulse $\overline{\text{RESET}}$ on the falling edge of CLK, as shown in Figure 15. Afterwards, the converters will be converting synchronously with the $\overline{\text{DRDY}}$ outputs updating simultaneously. After synchronization, allow 46 $\overline{\text{DRDY}}$ cycles (t_{12}) for output data to fully settle.

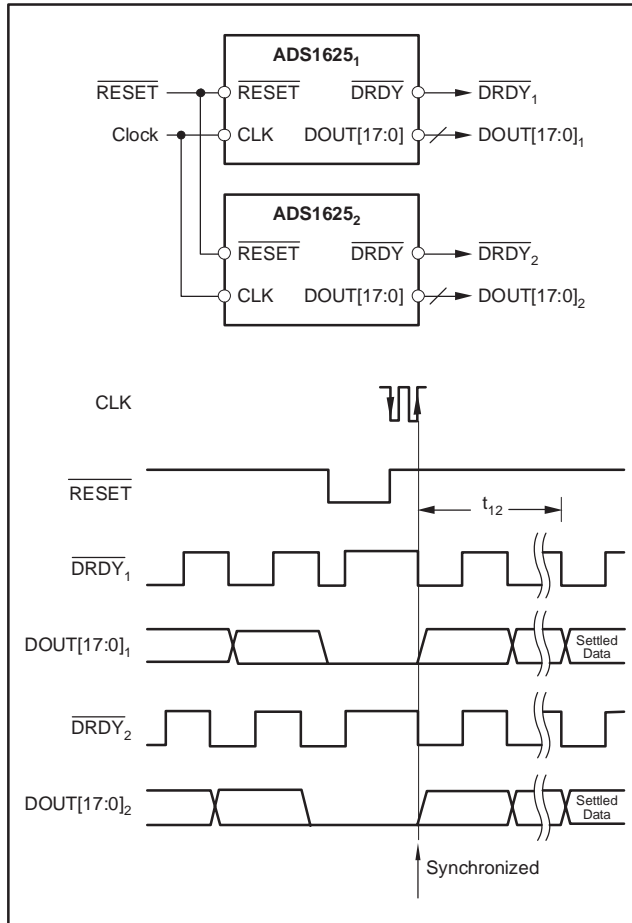

Figure 15. Synchronizing Multiple Converters

RESETTING THE ADS1626

The ADS1626 with the FIFO enabled requires a different reset sequence than the ADS1625, as shown in Figure 16. Ignore any $\overline{\text{DRDY}}$ toggles that occur while $\overline{\text{RESET}}$ is low. Release $\overline{\text{RESET}}$ on the rising edge of CLK, then afterwards toggle $\overline{\text{RD}}$ to complete the reset sequence.

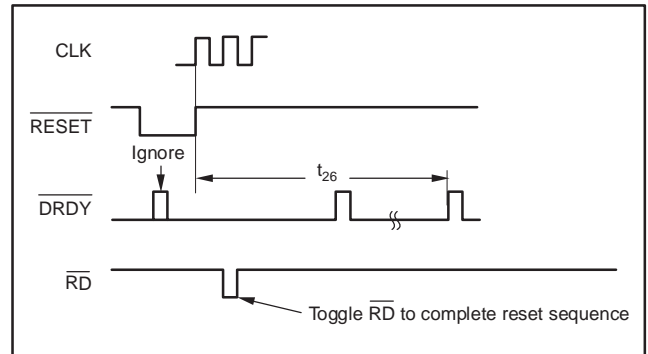

Figure 16. Resetting the ADS1626 with the FIFO Enabled

After resetting, the settling time for the ADS1626 is 46 CLK cycles, regardless of the FIFO level. Therefore, for higher FIFO levels, it takes fewer $\overline{\text{DRDY}}$ cycles to settle because the $\overline{\text{DRDY}}$ period is longer. Table 4 shows the number of $\overline{\text{DRDY}}$ cycles required to settle for each FIFO level.

Table 4. ADS1626 Reset Settling

FIFO LEVEL	FILTER SETTLING TIME AFTER RESET (t_{26} in units of $\overline{\text{DRDY}}$ cycles)
2	23
4	12
6	8
8	6
10	5
12	4
14	4

SETTLING TIME

The settling time is an important consideration when measuring signals with large steps or when using a multiplexer in front of the analog inputs. The ADS1625/6 digital filter requires time for an instantaneous change in signal level to propagate to the output.

Be sure to allow the filter time to settle after applying a large step in the input signal, switching the channel on a multiplexer placed in front of the inputs, resetting the ADS1625/6, or exiting the power-down mode.

Figure 17 shows the settling error as a function of time for a full-scale signal step applied at $t = 0$. This figure uses \overline{DRDY} cycles for the time scale (X-axis). After 46 \overline{DRDY} cycles, the settling error drops below 0.001%. For $f_{CLK} = 40\text{MHz}$, this corresponds to a settling time of $36.8\mu\text{s}$.

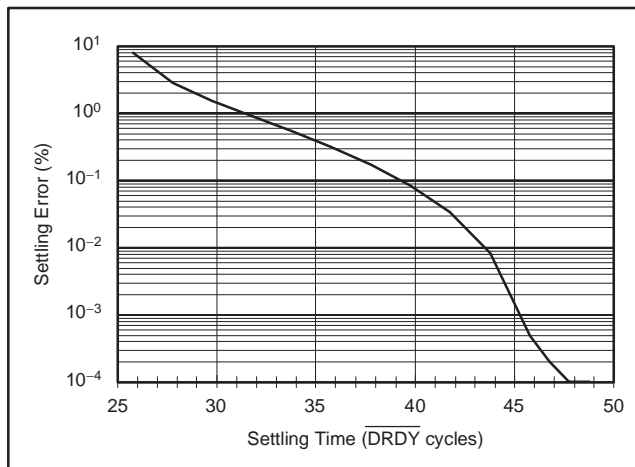

Figure 17. Settling Time

IMPULSE RESPONSE

Figure 18 plots the normalized response for an input applied at $t = 0$. The X-axis units of time are \overline{DRDY} cycles. As shown in Figure 18, the peak of the impulse takes 26 \overline{DRDY} cycles to propagate to the output. For $f_{CLK} = 40\text{MHz}$, a \overline{DRDY} cycle is $0.8\mu\text{s}$ in duration and the propagation time (or group delay) is $26 \times 0.8\mu\text{s} = 20.8\mu\text{s}$.

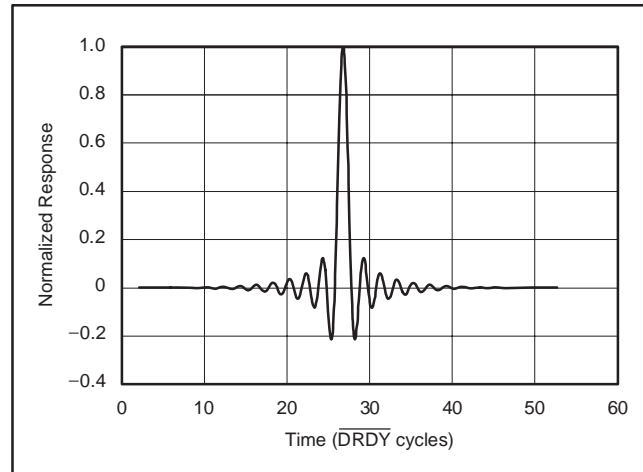

Figure 18. Impulse Response

FREQUENCY RESPONSE

The linear phase FIR digital filter sets the overall frequency response. Figure 19 shows the frequency response from dc to 20MHz for $f_{CLK} = 40\text{MHz}$. The frequency response of the ADS1625/6 filter scales directly with CLK frequency. For example, if the CLK frequency is decreased by half (to 20MHz), the values on the X-axis in Figure 19 would need to be scaled by half, with the span becoming dc to 10MHz.

Figure 20 shows the passband ripple from dc to 550kHz ($f_{CLK} = 40\text{MHz}$). Figure 21 shows a closer view of the passband transition by plotting the response from 500kHz to 640kHz ($f_{CLK} = 40\text{MHz}$).

The overall frequency response repeats at multiples of the CLK frequency. To help illustrate this, Figure 22 shows the response out to 120MHz ($f_{CLK} = 40\text{MHz}$). Notice how the passband response repeats at 40MHz, 80MHz and 120MHz; it is important to consider this when there is high-frequency noise present with the signal. The modulator bandwidth extends to 100MHz. High-frequency noise around 40MHz and 80MHz will not be attenuated by either the modulator or the digital filter. This noise will alias back in-band and reduce the overall SNR performance unless it is filtered out prior to the ADS1625/6. To prevent this, place an anti-alias filter in front of the ADS1625/6 that rolls off before 39MHz.

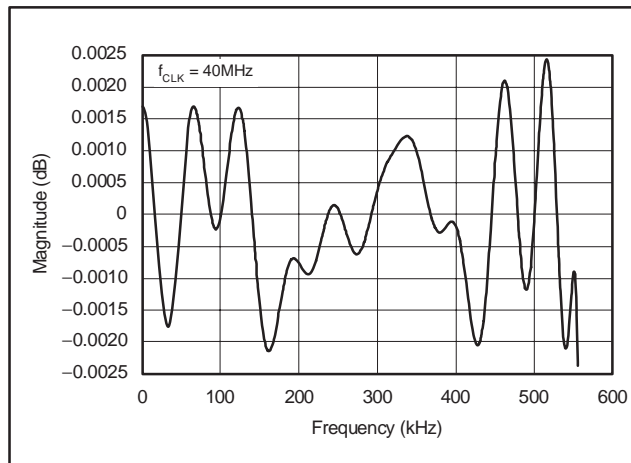

Figure 20. Passband Ripple

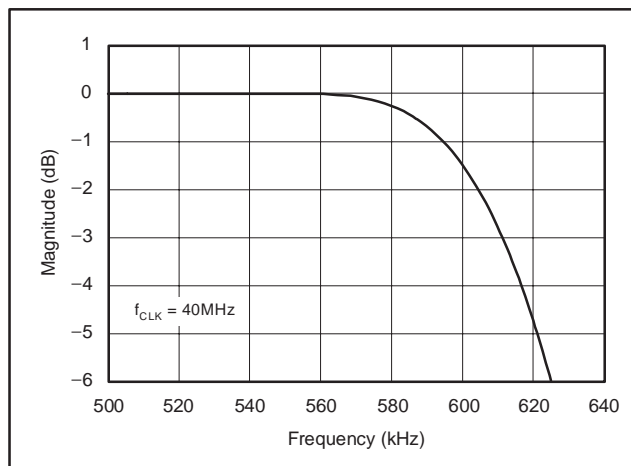

Figure 21. Passband Transition

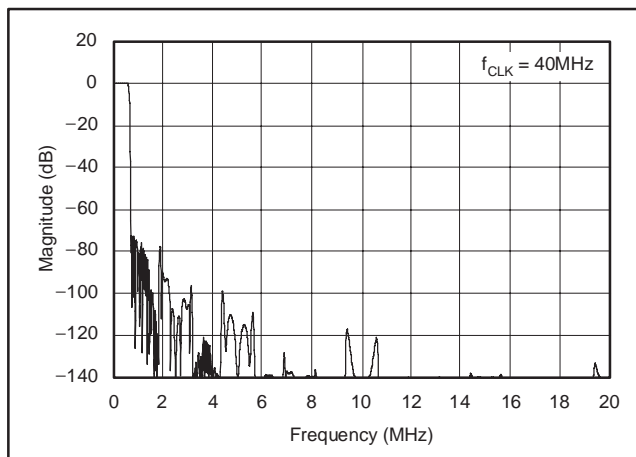

Figure 19. Frequency Response.

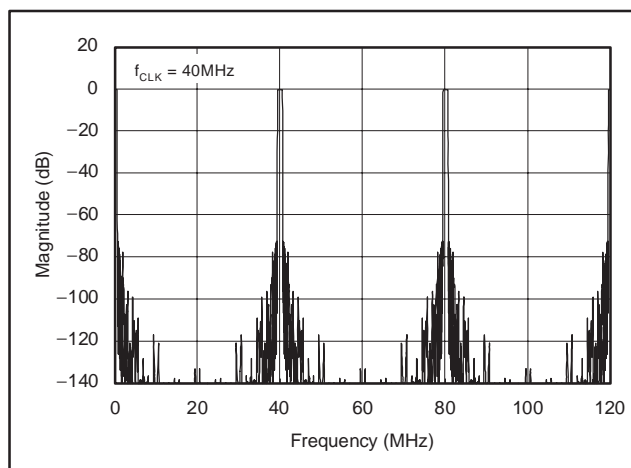

Figure 22. Frequency Response Out to 120MHz

FIFO (ADS1626 ONLY)

The ADS1626 includes an adjustable level first-in first-out buffer (FIFO) for the output data. The FIFO allows data to be temporarily stored within the ADS1626 to provide more flexibility for the host controller when retrieving data. Pins FIFO_LEV[2:0] set the level or depth of the FIFO. *Note that these pins must be left unconnected on the ADS1625.* The FIFO is enabled by setting at least one of the FIFO_LEV inputs high. Table 5 shows the corresponding FIFO level and $\overline{\text{DRDY}}$ period for the different combinations of FIFO_LEV[2:0] settings. For the best performance when using the FIFO, it is recommended to:

1. Set IOVDD = 3V.
2. Synchronize data retrieval with CLK.
3. Minimize loading on outputs DOUT[17:0].
4. Ensure rise and fall times on CLK and $\overline{\text{RD}}$ are 1ns or longer.

Table 5. FIFO Buffer Level Settings for the ADS1626

FIFO_LEV[2:0]	FIFO BUFFER LEVEL	$\overline{\text{DRDY}}$ PERIOD
000	0: disabled, operates like ADS1625	32/fCLK
001	2	64/fCLK
010	4	128/fCLK
011	6	192/fCLK
100	8	256/fCLK
101	10	320/fCLK
110	12	384/fCLK
111	14	448/fCLK

FIFO Operation

The ADS1626 FIFO collects the number of output readings set by the level corresponding to the FIFO_LEV[2:0] setting. When the specified level is reached, $\overline{\text{DRDY}}$ is pulsed high, indicating the data in the FIFO are ready to be read. The $\overline{\text{DRDY}}$ period is a function of the FIFO level, as shown in Table 5. To read the data, make sure $\overline{\text{CS}}$ is low (it is acceptable to tie it low) and then take $\overline{\text{RD}}$ low. The first, or oldest, data will be presented on the data output pins. After reading this data, advance to the next data reading by toggling $\overline{\text{RD}}$. On the next falling edge

of $\overline{\text{RD}}$, the second data are present on the data output pins. Continue this way until all the data have been read from the FIFO, making sure to take $\overline{\text{RD}}$ high when complete. Afterwards, wait until $\overline{\text{DRDY}}$ toggles and repeat the readback cycle. Figure 23 shows an example readback when FIFO_LEV[2:0] = 010 (level = 4).

Readback considerations

The exact number of data readings set by the FIFO level must be read back each time $\overline{\text{DRDY}}$ toggles. The one exception is that readback can be skipped entirely. In this case, the $\overline{\text{DRDY}}$ period increases to 512 CLK period. Figure 24 illustrates an example when readback is skipped with the FIFO level = 4. Do not read back more or less readings from the FIFO than set by the level. This interrupts the FIFO operation and can cause $\overline{\text{DRDY}}$ to stay low indefinitely. If this occurs, the $\overline{\text{RESET}}$ pin must be toggled followed by a $\overline{\text{RD}}$ pulse. This resets the ADS1626 FIFO and also the digital filter, which must settle afterwards before valid data is ready. See the section, *Resetting the ADS1626*, for more details. Also note that the $\overline{\text{RD}}$ signal is independent of the $\overline{\text{CS}}$ signal. Therefore, when multiple devices are used, the $\overline{\text{RD}}$ signal should not be shared. Alternatively, individual $\overline{\text{RD}}$ signals can be generated by performing an OR operation with the $\overline{\text{CS}}$ signal.

Setting the FIFO Level

The FIFO level setting is usually a static selection that is set when power is first applied to the ADS1626. If the FIFO level needs to be changed after powerup, there are two options. One is to asynchronously set the new value on pin FIFO_LEV[2:0] then toggle $\overline{\text{RESET}}$. Remember that the ADS1626 will need to settle after resetting. See the section, *Resetting the ADS1626*, for more details. The other option avoids requiring a reset, but needs synchronization of the FIFO level change with the readback. The FIFO_LEV[2:0] pins have to be changed after $\overline{\text{RD}}$ goes high after reading the first data, but before $\overline{\text{RD}}$ goes low to read the last data from the FIFO. The new FIFO level becomes active immediately and the $\overline{\text{DRDY}}$ period adjusts accordingly. When decreasing the FIFO level this way, make sure to give adequate time for readback of the data before setting the new, smaller level. Figure 25 illustrates an example of a synchronized FIFO level change from 4 to 8.

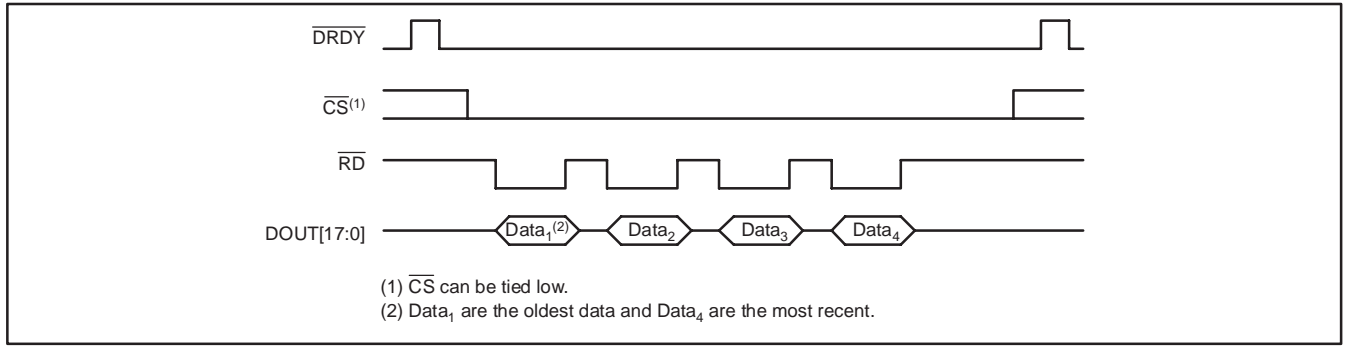

Figure 23. Example of FIFO Readback when FIFO Level = 4

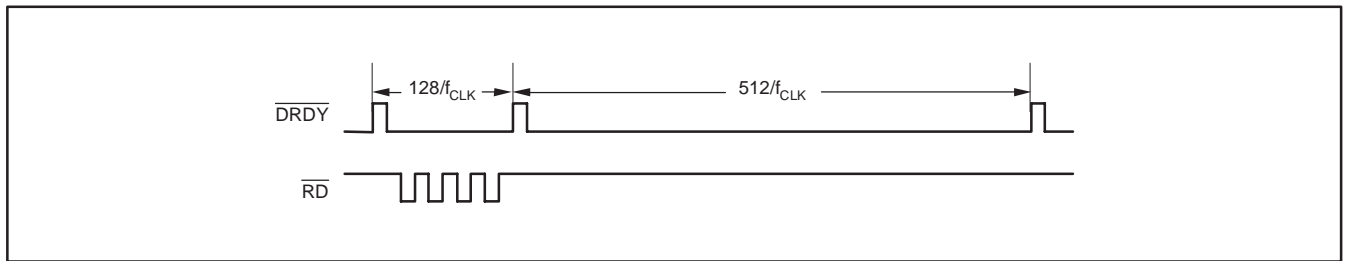

Figure 24. Example of Skipping Readback when FIFO Level = 4

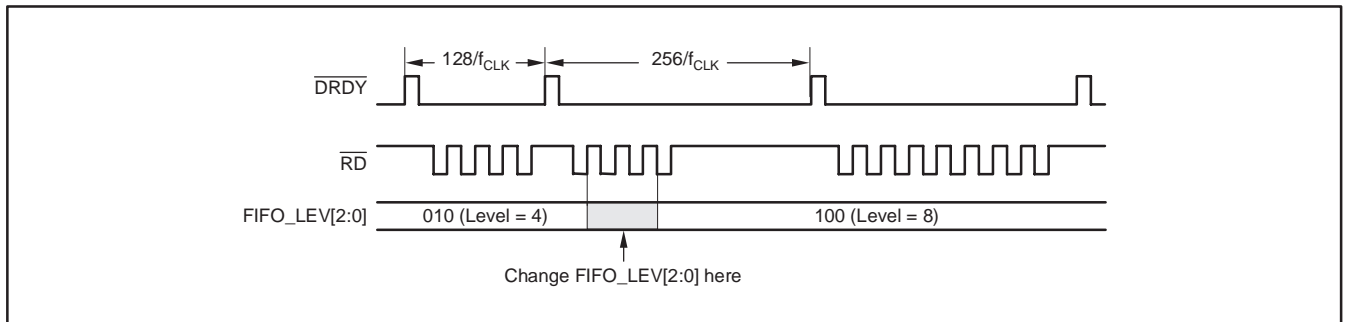

Figure 25. Example of Synchronized Change of FIFO Level from 4 to 8

ANALOG POWER DISSIPATION

An external resistor connected between the R_{BIAS} pin and the analog ground sets the analog current level, as shown in Figure 26. The current is inversely proportional to the resistor value. Table 6 shows the recommended values of R_{BIAS} for different CLK frequencies. Notice that the analog current can be reduced when using a slower frequency CLK input, because the modulator has more time to settle. Avoid adding any capacitance in parallel to R_{BIAS}, since this will interfere with the internal circuitry used to set the biasing.

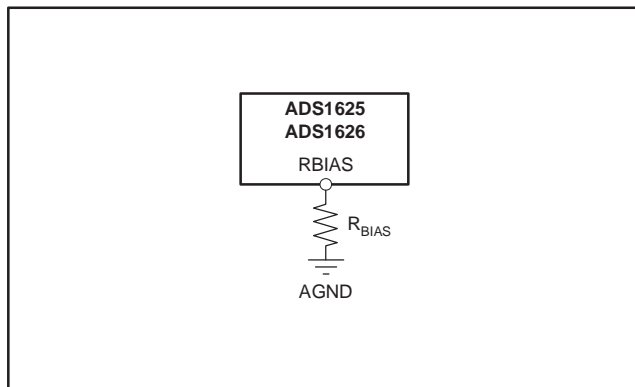

Figure 26. External Resistor Used to Set Analog Power Dissipation

Table 6. Recommended R_{BIAS} Resistor Values for Different CLK Frequencies

f _{CLK}	DATA RATE	R _{BIAS}	TYPICAL POWER DISSIPATION WITH REFEN HIGH
10MHz	312.5kHz	65kΩ	150mW
20MHz	625kHz	60kΩ	305mW
30MHz	937.5kHz	50kΩ	390mW
40MHz	1.25MHz	37kΩ	515mW

POWER DOWN (\overline{PD})

When not in use, the ADS1625/6 can be powered down by taking the \overline{PD} pin low. All circuitry will be shutdown, including the voltage reference. To minimize the digital current during power down, stop the clock signal supplied to the CLK input. There is an internal pull-up resistor of 170kΩ on the \overline{PD} pin, but it is recommended that this pin be connected to IOVDD if not used. If using the ADS1626 with the FIFO enabled, issue a reset after exiting the power-down mode. Make sure to allow time for the reference to start up after exiting power-down mode. The internal reference typically requires 15ms. After the reference has stabilized, allow at least 100 \overline{DRDY} cycles for the modulator and digital filter to settle before retrieving data.

POWER SUPPLIES

Three supplies are used on the ADS1625/6: analog (AVDD), digital (DVDD) and digital I/O (IOVDD). Each supply must be suitably bypassed to achieve the best performance. It is recommended that a 1μF and 0.1μF ceramic capacitor be placed as close to each supply pin as possible. Connect each supply-pin bypass capacitor to the associated ground, see Figure 27. Each main supply bus should also be bypassed with a bank of capacitors from 47μF to 0.1μF, as shown.

The IO and digital supplies (IOVDD and DVDD) can be connected together when using the same voltage. In this case, only one bank of 47μF to 0.1μF capacitors is needed on the main supply bus, though each supply pin must still be bypassed with a 1μF and 0.1μF ceramic capacitor.

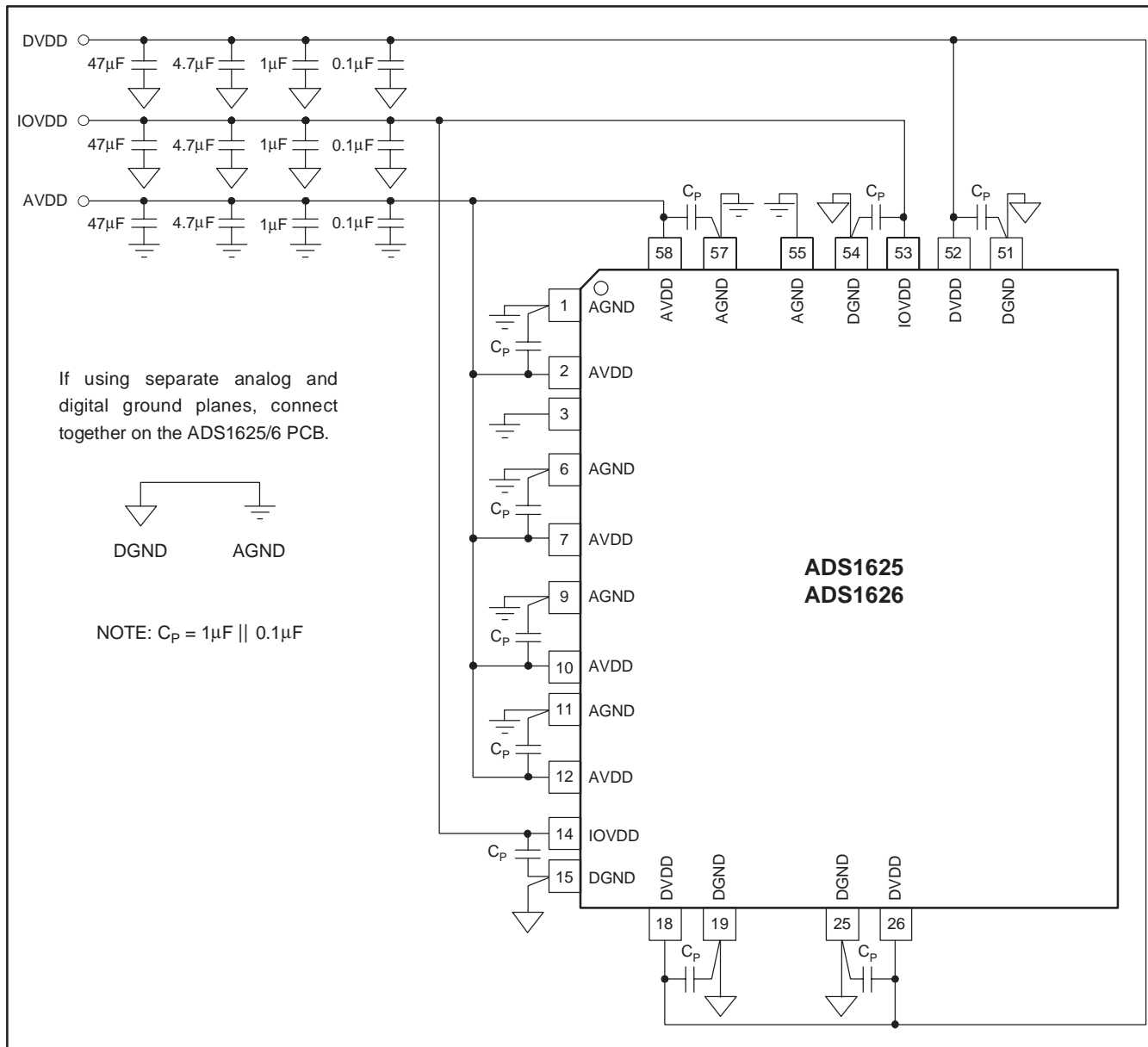

Figure 27. Recommended Power-Supply Bypassing

LAYOUT ISSUES

The ADS1625/6 is a very high-speed, high-resolution data converter. In order to achieve the maximum performance, careful attention must be given to the printed circuit board (PCB) layout. Use good high-speed techniques for all circuitry. Critical capacitors should be placed close to pins as possible. These include capacitors directly connected to the analog and reference inputs and the power supplies. Make sure to also properly bypass all circuitry driving the inputs and references.

There are two possible approaches for the ground plane on the PCB: a single common plane or two separate planes, one for the analog grounds and one for the digital grounds. When using only one common plane, isolate the flow of current on pin 58 from pin 1; use breaks on the ground plane to accomplish this. Pin 58 carries the switching current from the analog clocking for the modulator and can corrupt the quiet analog ground on pin 1. When using two planes, it is recommended that they be tied together right at the PCB. Do not try to connect the ground planes together after running separately through edge connectors or cables as this reduces performance and increases the likelihood of latchup.

In general, keep the resistances used in the driving circuits for the inputs and reference low to prevent excess thermal noise from degrading overall performance. Avoid having the ADS1625/6 digital outputs drive heavy loads. Buffers on the outputs are recommended unless the ADS1625/6 is connected directly to a DSP or controller situated nearby. Additionally, make sure the digital inputs are driven with clean signals as ringing on the inputs can introduce noise.

The ADS1625/6 uses TI PowerPAD technology. The PowerPAD is physically connected to the substrate of the silicon inside the package and must be soldered to the analog ground plane on the PCB using the exposed metal pad underneath the package for proper heat dissipation. Please refer to application report SLMA002, located at www.ti.com, for more details on the PowerPAD package.

APPLICATIONS

INTERFACING THE ADS1625 TO THE TMS320C6000

Figure 28 illustrates how to directly connect the ADS1625 to the TMS320C6000 DSP. The processor controls reading using output \overline{ARE} . The ADS1625 is selected using the DSP control output, $\overline{CE2}$. The ADS1625 18-bit data output bus is directly connected to the TMS320C6000 data bus. The data ready output from the ADS1625, \overline{DRDY} , drives interrupt $\overline{EXT_INT7}$ on the TMS320C6000.

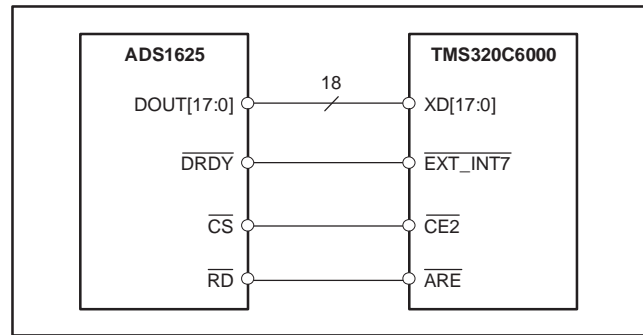

Figure 28. ADS1625—TMS320C6000 Interface Connection

INTERFACING THE ADS1626 TO THE TMS320C6000

Figure 29 illustrates how to directly connect the ADS1626 to the TMS320C6000 DSP. The processor controls reading using output \overline{ARE} . The ADS1626 is permanently selected by grounding the \overline{CS} pin. The ADS1626 18-bit data output bus is directly connected to the TMS320C6000 data bus. The data ready output from the ADS1626, \overline{DRDY} , drives interrupt $\overline{EXT_INT7}$ on the TMS320C6000.

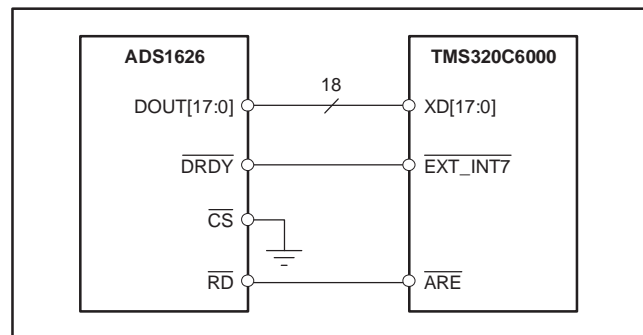

Figure 29. ADS1626—TMS320C6000 Interface Connection

INTERFACING THE ADS1625 TO THE TMS320VC5510

Figure 30 illustrates how to connect the ADS1625 to the TMS320VC5510 DSP. The DSP controls reading using output $\overline{\text{ARE}}$. The ADS1625 is selected using the DSP control output $\overline{\text{CE2}}$. The ADS1625 18-bit data output bus is directly connected to the TMS320VC5510 data bus. The data ready output from the ADS1625, $\overline{\text{DRDY}}$, drives the $\overline{\text{INT3}}$ interrupt line on the TMS320VC5510.

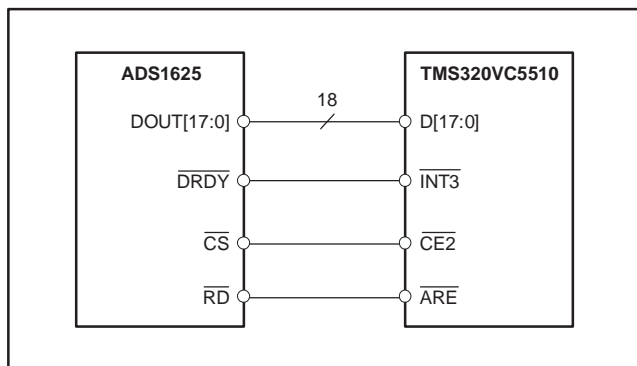

Figure 30. ADS1625—TMS320VC5510 Interface Connection

INTERFACING THE ADS1626 TO THE TMS320VC5510

Figure 31 illustrates how to directly connect the ADS1626 to the TMS320VC5510 Digital Signal Processor. The processor controls reading the ADC using the $\overline{\text{ARE}}$ output. The ADS1626 is permanently selected by grounding the $\overline{\text{CS}}$ pin. If there are any additional devices connected to the TMS320VC5510 I/O space, address decode logic will be required between the ADC and the DSP to prevent data bus contention and ensure that only one device at a time is selected. The ADS1626 18-bit data output bus is directly connected to the TMS320VC5510. The data ready output from the ADS1626, $\overline{\text{DRDY}}$, drives interrupt $\overline{\text{INT3}}$ on the TMS320VC5510.

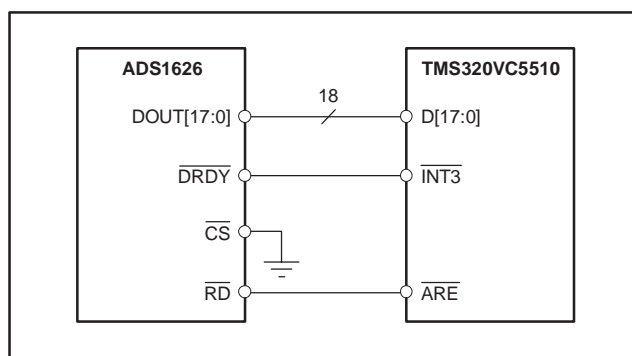

Figure 31. ADS1626—TMS320VC5510 Interface Connection

Code Composer Studio, available from TI, provides support for interfacing TI DSPs through a collection of data converter plugins. Check the TI web site, located at www.ti.com/sc/dcplug-in, for the latest information on ADS1625/6 support.

Revision History

DATE	REV	PAGE	SECTION	DESCRIPTION
5/16/07	E	24	Readback Considerations	Added last three sentences.

NOTE: Page numbers for previous revisions may differ from page numbers in the current version.

PACKAGING INFORMATION

Orderable Device	Status ⁽¹⁾	Package Type	Package Drawing	Pins	Package Qty	Eco Plan ⁽²⁾	Lead/Ball Finish	MSL Peak Temp ⁽³⁾
ADS1625IPAPR	ACTIVE	HTQFP	PAP	64	1000	Green (RoHS & no Sb/Br)	CU NIPDAU	Level-3-260C-168 HR
ADS1625IPAPRG4	ACTIVE	HTQFP	PAP	64	1000	Green (RoHS & no Sb/Br)	CU NIPDAU	Level-3-260C-168 HR
ADS1625IPAPT	ACTIVE	HTQFP	PAP	64	250	Green (RoHS & no Sb/Br)	CU NIPDAU	Level-3-260C-168 HR
ADS1625IPAPTG4	ACTIVE	HTQFP	PAP	64	250	Green (RoHS & no Sb/Br)	CU NIPDAU	Level-3-260C-168 HR
ADS1626IPAPR	ACTIVE	HTQFP	PAP	64	1000	Green (RoHS & no Sb/Br)	CU NIPDAU	Level-3-260C-168 HR
ADS1626IPAPRG4	ACTIVE	HTQFP	PAP	64	1000	Green (RoHS & no Sb/Br)	CU NIPDAU	Level-3-260C-168 HR
ADS1626IPAPT	ACTIVE	HTQFP	PAP	64	250	Green (RoHS & no Sb/Br)	CU NIPDAU	Level-3-260C-168 HR
ADS1626IPAPTG4	ACTIVE	HTQFP	PAP	64	250	Green (RoHS & no Sb/Br)	CU NIPDAU	Level-3-260C-168 HR

⁽¹⁾ The marketing status values are defined as follows:

ACTIVE: Product device recommended for new designs.

LIFEBUY: TI has announced that the device will be discontinued, and a lifetime-buy period is in effect.

NRND: Not recommended for new designs. Device is in production to support existing customers, but TI does not recommend using this part in a new design.

PREVIEW: Device has been announced but is not in production. Samples may or may not be available.

OBSOLETE: TI has discontinued the production of the device.

⁽²⁾ Eco Plan - The planned eco-friendly classification: Pb-Free (RoHS), Pb-Free (RoHS Exempt), or Green (RoHS & no Sb/Br) - please check <http://www.ti.com/productcontent> for the latest availability information and additional product content details.

TBD: The Pb-Free/Green conversion plan has not been defined.

Pb-Free (RoHS): TI's terms "Lead-Free" or "Pb-Free" mean semiconductor products that are compatible with the current RoHS requirements for all 6 substances, including the requirement that lead not exceed 0.1% by weight in homogeneous materials. Where designed to be soldered at high temperatures, TI Pb-Free products are suitable for use in specified lead-free processes.

Pb-Free (RoHS Exempt): This component has a RoHS exemption for either 1) lead-based flip-chip solder bumps used between the die and package, or 2) lead-based die adhesive used between the die and leadframe. The component is otherwise considered Pb-Free (RoHS compatible) as defined above.

Green (RoHS & no Sb/Br): TI defines "Green" to mean Pb-Free (RoHS compatible), and free of Bromine (Br) and Antimony (Sb) based flame retardants (Br or Sb do not exceed 0.1% by weight in homogeneous material)

⁽³⁾ MSL, Peak Temp. -- The Moisture Sensitivity Level rating according to the JEDEC industry standard classifications, and peak solder temperature.

Important Information and Disclaimer:The information provided on this page represents TI's knowledge and belief as of the date that it is provided. TI bases its knowledge and belief on information provided by third parties, and makes no representation or warranty as to the accuracy of such information. Efforts are underway to better integrate information from third parties. TI has taken and continues to take reasonable steps to provide representative and accurate information but may not have conducted destructive testing or chemical analysis on incoming materials and chemicals. TI and TI suppliers consider certain information to be proprietary, and thus CAS numbers and other limited information may not be available for release.

In no event shall TI's liability arising out of such information exceed the total purchase price of the TI part(s) at issue in this document sold by TI to Customer on an annual basis.

TAPE AND REEL INFORMATION

QUADRANT ASSIGNMENTS FOR PIN 1 ORIENTATION IN TAPE

*All dimensions are nominal

Device	Package Type	Package Drawing	Pins	SPQ	Reel Diameter (mm)	Reel Width W1 (mm)	A0 (mm)	B0 (mm)	K0 (mm)	P1 (mm)	W (mm)	Pin1 Quadrant
ADS1625IPAPR	HTQFP	PAP	64	1000	330.0	24.4	13.0	13.0	1.5	16.0	24.0	Q2
ADS1625IPAPT	HTQFP	PAP	64	250	330.0	24.4	13.0	13.0	1.5	16.0	24.0	Q2
ADS1626IPAPR	HTQFP	PAP	64	1000	330.0	24.4	13.0	13.0	1.5	16.0	24.0	Q2
ADS1626IPAPT	HTQFP	PAP	64	250	330.0	24.4	13.0	13.0	1.5	16.0	24.0	Q2

TAPE AND REEL BOX DIMENSIONS

*All dimensions are nominal

Device	Package Type	Package Drawing	Pins	SPQ	Length (mm)	Width (mm)	Height (mm)
ADS1625IPAPR	HTQFP	PAP	64	1000	346.0	346.0	41.0
ADS1625IPAPT	HTQFP	PAP	64	250	346.0	346.0	41.0
ADS1626IPAPR	HTQFP	PAP	64	1000	346.0	346.0	41.0
ADS1626IPAPT	HTQFP	PAP	64	250	346.0	346.0	41.0

PAP (S-PQFP-G64)

PowerPAD™ PLASTIC QUAD FLATPACK

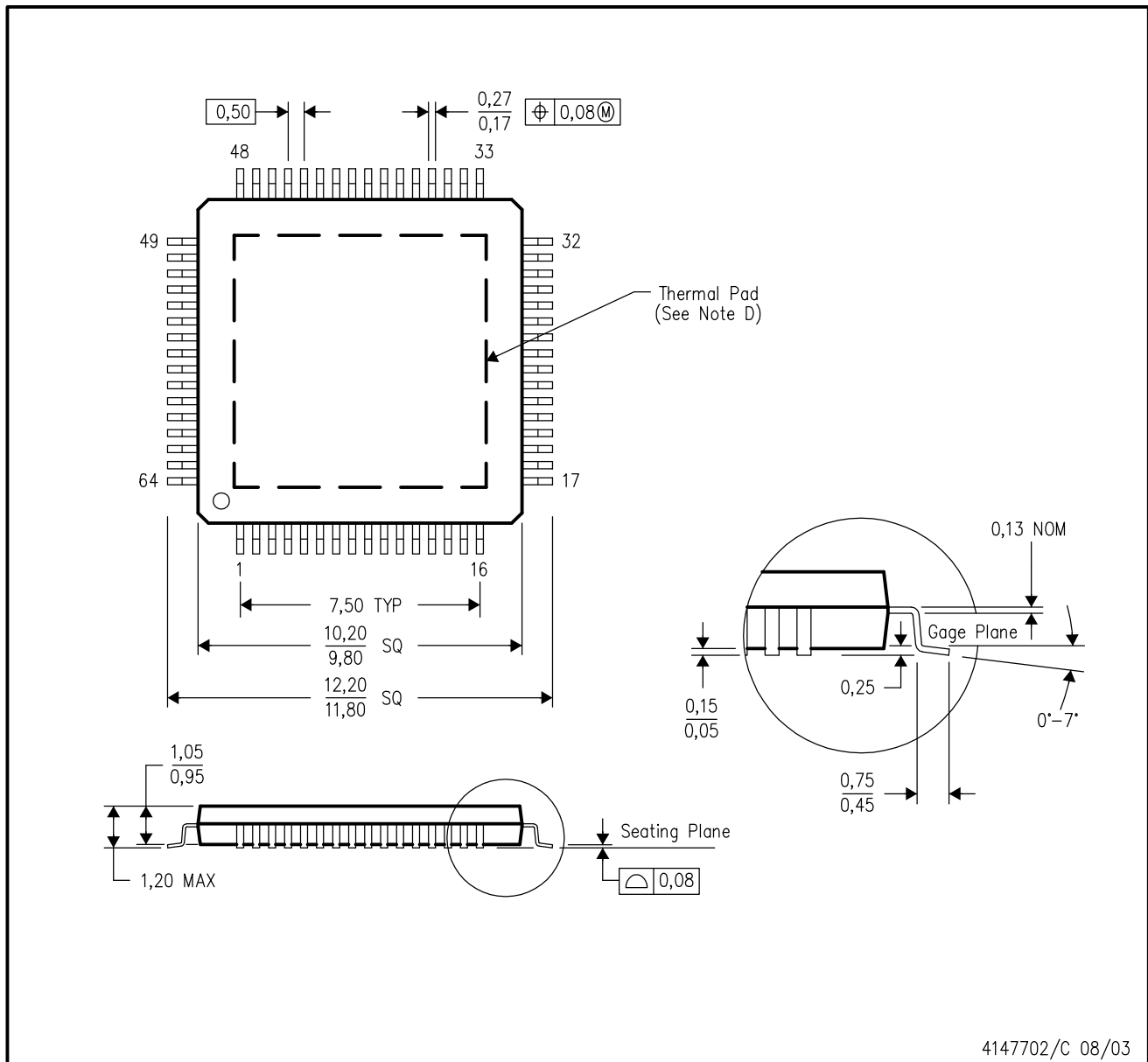

- NOTES:
- A. All linear dimensions are in millimeters.
 - B. This drawing is subject to change without notice.
 - C. Body dimensions do not include mold flash or protrusion
 - D. This package is designed to be soldered to a thermal pad on the board. Refer to Technical Brief, PowerPad Thermally Enhanced Package, Texas Instruments Literature No. SLMA002 for information regarding recommended board layout. This document is available at www.ti.com <<http://www.ti.com>>.
 - E. Falls within JEDEC MS-026

PowerPAD is a trademark of Texas Instruments.

THERMAL INFORMATION

This PowerPAD™ package incorporates an exposed thermal pad that is designed to be attached to a printed circuit board (PCB). The thermal pad must be soldered directly to the PCB. After soldering, the PCB can be used as a heatsink. In addition, through the use of thermal vias, the thermal pad can be attached directly to the appropriate copper plane shown in the electrical schematic for the device, or alternatively, can be attached to a special heatsink structure designed into the PCB. This design optimizes the heat transfer from the integrated circuit (IC).

For additional information on the PowerPAD package and how to take advantage of its heat dissipating abilities, refer to Technical Brief, PowerPAD Thermally Enhanced Package, Texas Instruments Literature No. SLMA002 and Application Brief, PowerPAD Made Easy, Texas Instruments Literature No. SLMA004. Both documents are available at www.ti.com.

The exposed thermal pad dimensions for this package are shown in the following illustration.

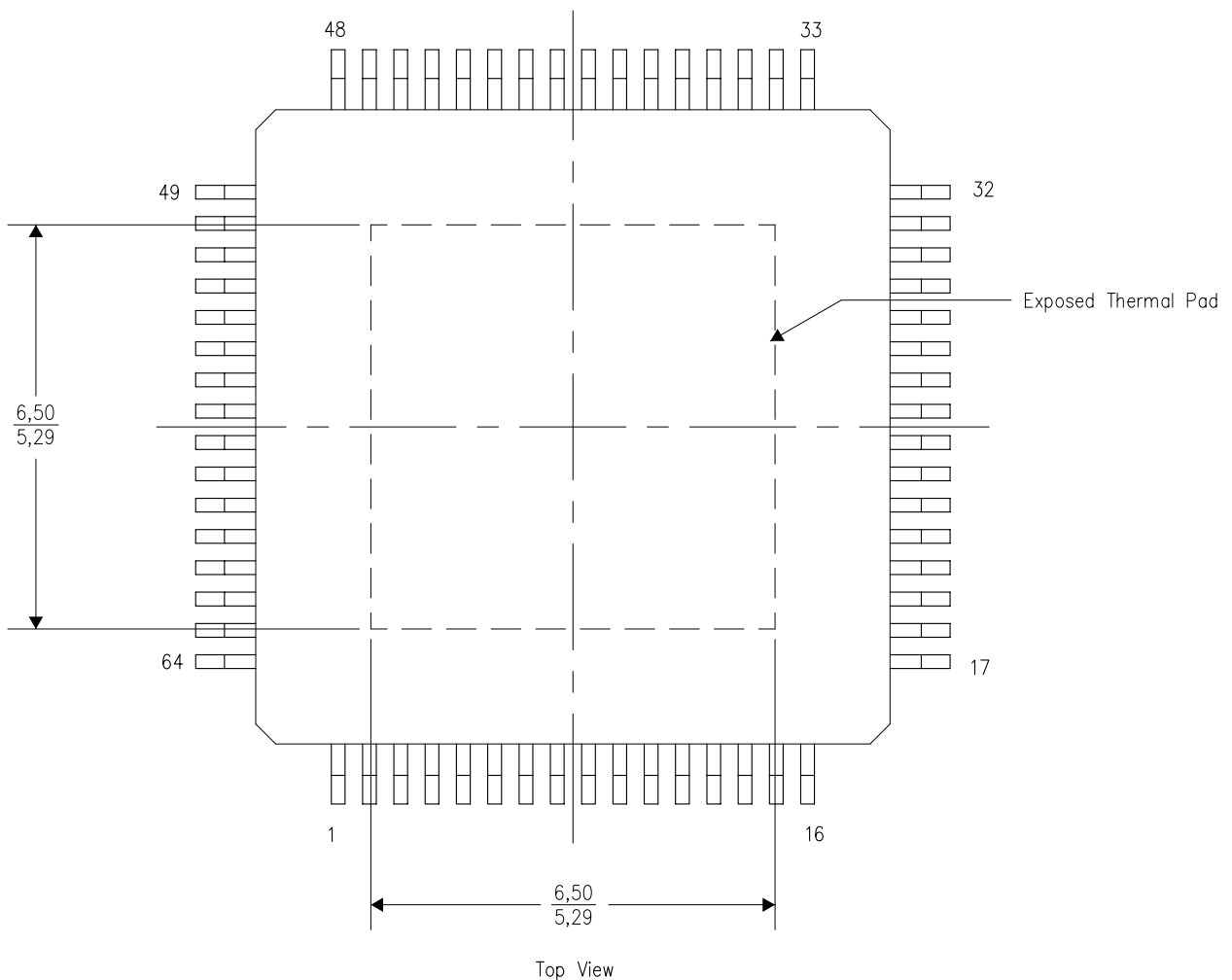

NOTE: All linear dimensions are in millimeters

Exposed Thermal Pad Dimensions

PAP (S-PQFP-G64) PowerPAD™

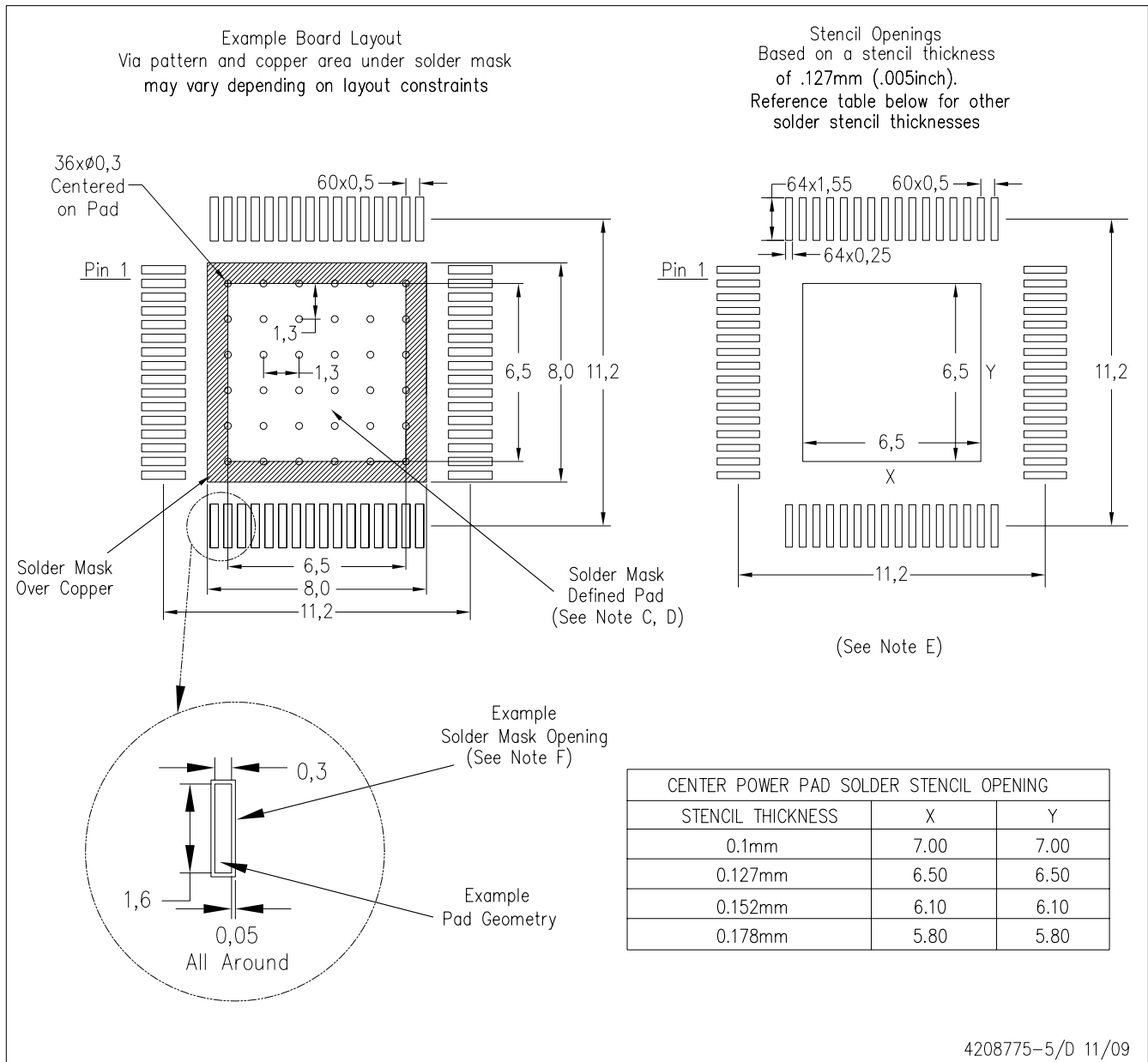

- NOTES:
- All linear dimensions are in millimeters.
 - This drawing is subject to change without notice.
 - Customers should place a note on the circuit board fabrication drawing not to alter the center solder mask defined pad.
 - This package is designed to be soldered to a thermal pad on the board. Refer to Technical Brief, PowerPAD Thermally Enhanced Package, Texas Instruments Literature No. SLMA002, SLMA004, and also the Product Data Sheets for specific thermal information, via requirements, and recommended board layout. These documents are available at www.ti.com <<http://www.ti.com>>. Publication IPC-7351 is recommended for alternate designs.
 - Laser cutting apertures with trapezoidal walls and also rounding corners will offer better paste release. Customers should contact their board assembly site for stencil design recommendations. Example stencil design based on a 50% volumetric metal load solder paste. Refer to IPC-7525 for other stencil recommendations.
 - Customers should contact their board fabrication site for solder mask tolerances between and around signal pads.

IMPORTANT NOTICE

Texas Instruments Incorporated and its subsidiaries (TI) reserve the right to make corrections, modifications, enhancements, improvements, and other changes to its products and services at any time and to discontinue any product or service without notice. Customers should obtain the latest relevant information before placing orders and should verify that such information is current and complete. All products are sold subject to TI's terms and conditions of sale supplied at the time of order acknowledgment.

TI warrants performance of its hardware products to the specifications applicable at the time of sale in accordance with TI's standard warranty. Testing and other quality control techniques are used to the extent TI deems necessary to support this warranty. Except where mandated by government requirements, testing of all parameters of each product is not necessarily performed.

TI assumes no liability for applications assistance or customer product design. Customers are responsible for their products and applications using TI components. To minimize the risks associated with customer products and applications, customers should provide adequate design and operating safeguards.

TI does not warrant or represent that any license, either express or implied, is granted under any TI patent right, copyright, mask work right, or other TI intellectual property right relating to any combination, machine, or process in which TI products or services are used. Information published by TI regarding third-party products or services does not constitute a license from TI to use such products or services or a warranty or endorsement thereof. Use of such information may require a license from a third party under the patents or other intellectual property of the third party, or a license from TI under the patents or other intellectual property of TI.

Reproduction of TI information in TI data books or data sheets is permissible only if reproduction is without alteration and is accompanied by all associated warranties, conditions, limitations, and notices. Reproduction of this information with alteration is an unfair and deceptive business practice. TI is not responsible or liable for such altered documentation. Information of third parties may be subject to additional restrictions.

Resale of TI products or services with statements different from or beyond the parameters stated by TI for that product or service voids all express and any implied warranties for the associated TI product or service and is an unfair and deceptive business practice. TI is not responsible or liable for any such statements.

TI products are not authorized for use in safety-critical applications (such as life support) where a failure of the TI product would reasonably be expected to cause severe personal injury or death, unless officers of the parties have executed an agreement specifically governing such use. Buyers represent that they have all necessary expertise in the safety and regulatory ramifications of their applications, and acknowledge and agree that they are solely responsible for all legal, regulatory and safety-related requirements concerning their products and any use of TI products in such safety-critical applications, notwithstanding any applications-related information or support that may be provided by TI. Further, Buyers must fully indemnify TI and its representatives against any damages arising out of the use of TI products in such safety-critical applications.

TI products are neither designed nor intended for use in military/aerospace applications or environments unless the TI products are specifically designated by TI as military-grade or "enhanced plastic." Only products designated by TI as military-grade meet military specifications. Buyers acknowledge and agree that any such use of TI products which TI has not designated as military-grade is solely at the Buyer's risk, and that they are solely responsible for compliance with all legal and regulatory requirements in connection with such use.

TI products are neither designed nor intended for use in automotive applications or environments unless the specific TI products are designated by TI as compliant with ISO/TS 16949 requirements. Buyers acknowledge and agree that, if they use any non-designated products in automotive applications, TI will not be responsible for any failure to meet such requirements.

Following are URLs where you can obtain information on other Texas Instruments products and application solutions:

Products		Applications	
Amplifiers	amplifier.ti.com	Audio	www.ti.com/audio
Data Converters	dataconverter.ti.com	Automotive	www.ti.com/automotive
DLP® Products	www.dlp.com	Communications and Telecom	www.ti.com/communications
DSP	dsp.ti.com	Computers and Peripherals	www.ti.com/computers
Clocks and Timers	www.ti.com/clocks	Consumer Electronics	www.ti.com/consumer-apps
Interface	interface.ti.com	Energy	www.ti.com/energy
Logic	logic.ti.com	Industrial	www.ti.com/industrial
Power Mgmt	power.ti.com	Medical	www.ti.com/medical
Microcontrollers	microcontroller.ti.com	Security	www.ti.com/security
RFID	www.ti-rfid.com	Space, Avionics & Defense	www.ti.com/space-avionics-defense
RF/IF and ZigBee® Solutions	www.ti.com/lprf	Video and Imaging	www.ti.com/video
		Wireless	www.ti.com/wireless-apps

Mailing Address: Texas Instruments, Post Office Box 655303, Dallas, Texas 75265
Copyright © 2010, Texas Instruments Incorporated

www.BDTIC.com/TI/