

FEATURES

- **Wide Power-Supply Voltage Range**
 - Single Supply: 3 V to 32 V
 - Dual Supply: ± 1.5 V to ± 16 V
- **Low Supply-Current Drain Essentially Independent of Supply Voltage: 600 μ A**
- **Low Input Biasing Current: 50 nA**
- **Low Input Offset Voltage: 2 mV**
- **Low Input Offset Current: 5 nA**
- **Input Common-Mode Voltage Range Includes Ground**
- **Differential Input Voltage Range Equals Power-Supply Voltage**
- **Additional Operational Amplifier Features**
 - Internally Frequency Compensated for Unity Gain
 - Large DC Voltage Gain: 100 dB
 - Wide Bandwidth (Unity Gain): 1 MHz
 - Large Output Voltage Swing: 0 V to $V_+ - 1.5$ V

- **Additional Comparator Features**
 - Low Output Saturation Voltage: 250 mV at 4 mA
 - Output Voltage Compatible With All Types of Logic Systems

ADVANTAGES

- **Eliminates Need for Dual Power Supplies**
- **An Internally Compensated Operational Amplifier and a Precision Comparator in the Same Package**
- **Allows Sensing at or Near Ground**

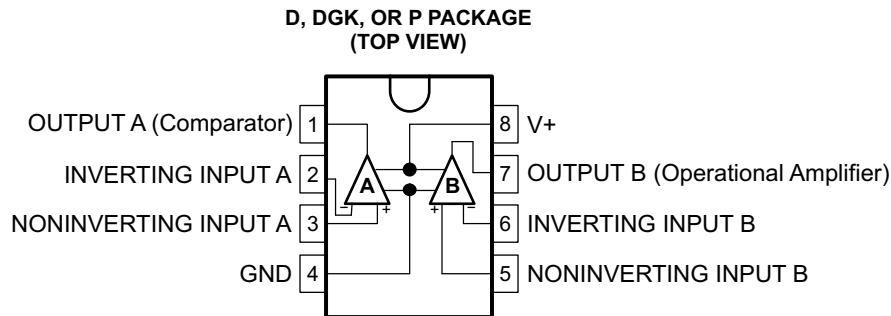

DESCRIPTION/ORDERING INFORMATION

The LM392 consists of two independent building-block circuits. One is a high-gain internally-frequency-compensated operational amplifier, and the other is a precision voltage comparator. Both the operational amplifier and the voltage comparator are designed to operate from a single power supply over a wide range of voltages. Both circuits have input stages that force the common-mode input down to ground when operating from a single power supply. Operation from split power supplies also is possible, and the low power-supply current is independent of the magnitude of the supply voltage.

Applications include transducer amplifiers with pulse shapers, DC gain blocks with level detectors, and VCOs, as well as all conventional operational amplifier or voltage-comparator circuits. The LM392 can be operated directly from the standard 5-V power-supply voltage used in digital systems, and the output of the comparator interfaces directly with either TTL or CMOS logic. In addition, the low-power drain makes the LM392 extremely useful in the design of portable equipment.



Please be aware that an important notice concerning availability, standard warranty, and use in critical applications of Texas Instruments semiconductor products and disclaimers thereto appears at the end of this data sheet.

ORDERING INFORMATION

T _A	PACKAGE ⁽¹⁾		ORDERABLE PART NUMBER	TOP-SIDE MARKING
0°C to 70°C	MSOP – DGK	Reel of 250	LM392DGKT	PREVIEW
		Reel of 2500	LM392DGKR	
	PDIP – P	Tube of 50	LM392P	LM392P
	SOIC – D	Tube of 75	LM392D	LM392
		Reel of 2500	LM392DR	

(1) Package drawings, standard packing quantities, thermal data, symbolization, and PCB design guidelines are available at www.ti.com/sc/package.

SCHEMATIC DIAGRAM

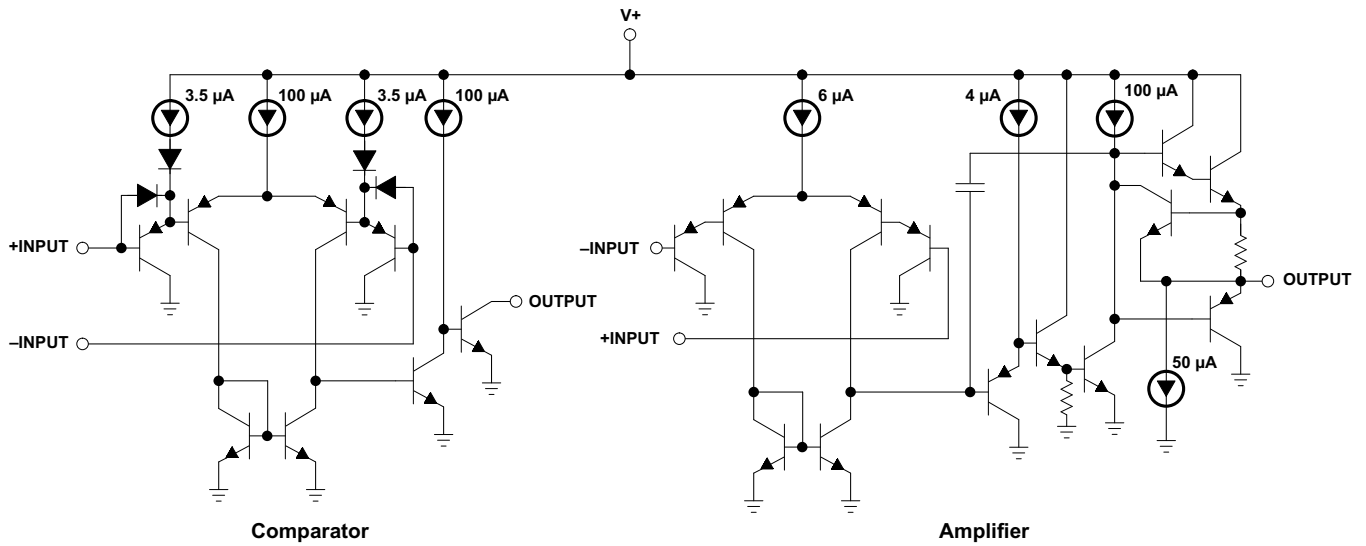

Absolute Maximum Ratings⁽¹⁾

over operating free-air temperature range (unless otherwise noted)

		MIN	MAX	UNIT
V+	Supply voltage	Single supply	32	V
		Dual supply	±16	
V _{ID}	Differential input voltage		32	V
V _{IN}	Input voltage range	–0.3	32	V
I _I	Input current ⁽²⁾	V _{IN} < –0.3 V	50	mA
t _{short}	Duration of output short circuit to ground ⁽³⁾		Continuous	
θ _{JA}	Package thermal impedance, junction to free air ⁽⁴⁾	D package	97	°C/W
		DGK package	172	
		P package	84	
T _{lead}	Lead temperature during soldering	10 s maximum	260	°C
T _{stg}	Storage temperature range	–65	150	°C

- (1) Stresses beyond those listed under *Absolute Maximum Ratings* may cause permanent damage to the device. These are stress ratings only, and functional operation of the device at these or any other conditions beyond those indicated under *Recommended Operating Conditions* is not implied. Exposure to absolute-maximum-rated conditions for extended periods may affect device reliability.
- (2) This input current exists only when the voltage at any of the input leads is driven negative. It is due to the collector-base junction of the input PNP transistors becoming forward biased and thereby acting as input diode clamps. In addition to this diode action, there is also lateral NPN parasitic transistor action on the device. This transistor action can cause the output voltages of the amplifiers to go to the V+ voltage level (or to ground for a large overdrive) for the time duration that an input is driven negative. This is not destructive, and normal output states reestablish when the input voltage, which was negative, again returns to a value greater than –0.3 V (at 25°C).
- (3) Short circuits from the output to V+ can cause excessive heating and eventual destruction. When considering short circuits to ground, the maximum output current is approximately 40 mA for the operational amplifier and 30 mA for the comparator, independent of the magnitude of V+. At values of supply voltage in excess of 15 V, continuous short circuits can exceed the power dissipation ratings and cause eventual destruction.
- (4) Package thermal impedance is calculated in accordance with JESD 51-7.

Recommended Operating Conditions

		MIN	MAX	UNIT
V+	Supply voltage	Single supply	3 32	V
		Dual supply	±1.5 ±16	
T _A	Operating free-air temperature	0	70	°C

Electrical Characteristics

V+ = 5 V (unless otherwise noted)

PARAMETER		TEST CONDITIONS		T _A	MIN	TYP	MAX	UNIT
V _{IO}	Input offset voltage	At output switch point, V _O ≈ 1.4 V, R _S = 0 Ω, V+ = 5 V to 30 V, V _{CM} = 0 V to (V+ – 1.5 V)		25°C		±2	±5	mV
				0°C to 70°C				
I _{IB}	Input bias current	IN(+) or IN(–), V _{CM} = 0 V ⁽¹⁾		25°C		50	205	nA
				0°C to 70°C				
I _{IO}	Input offset current	IN(+) – IN(–)		25°C		±5	±50	nA
				0°C to 70°C				
V _{CM}	Input common-mode voltage ⁽²⁾	V+ = 30 V		25°C	0		V+ – 1.5	V
				0°C to 70°C	0			
I+	Supply current	R _L = ∞	V+ = 30 V	0°C to 70°C		1	2	mA
			V+ = 5 V			0.5	1	
	Amplifier-to-amplifier coupling	f = 1 kHz to 20 kHz, Input referred ⁽³⁾		25°C		–100		dB
V _{DI}	Differential input voltage	All V _{IN} ≥ 0 V (or V–, if used) ⁽⁴⁾		0°C to 70°C			32	V

- (1) The direction of the input current is out of the device due to the PNP input stage. This current essentially is constant and independent of the state of the output, so no loading change exists on the input lines.
- (2) The input common-mode voltage or either input signal voltage should not be allowed to go negative by more than 0.3 V. The upper end of the common-mode voltage range is V+ – 1.5 V, but either or both inputs can go to 32 V without damage.
- (3) Due to proximity of external components, ensure that coupling is not originating via the stray capacitance between these external parts. This typically can be detected, as this type of capacitive coupling increases at higher frequencies.
- (4) Positive excursions of input voltage may exceed the power-supply level. As long as the other input voltage remains within the common-mode range, the comparator provides a proper output state. The input voltage to the operational amplifier should not exceed the power-supply level. The input voltage state must not be less than –0.3 V (or 0.3 V below the magnitude of the negative power supply, if used) on either amplifier.

Electrical Characteristics, Operational Amplifier Only

V+ = 5 V (unless otherwise noted)

PARAMETER		TEST CONDITIONS		T _A	MIN	TYP	MAX	UNIT
A _{VD}	Large signal voltage gain	V+ = 15 V, V _O swing = 1 V to 11 V, R _L = 2 kΩ		25°C	25	100		V/mV
V _{OS}	Output voltage swing	R _L = 2 kΩ		25°C	0		V+ – 1.5	V
CMRR	Common-mode rejection ratio	V _{CM} = 0 V to (V+ – 1.5 V)		25°C	65	70		dB
k _{SVR}	Power-supply rejection ratio			25°C	65	100		dB
I _{source}	Output source current	V _{IN(+)} = 1 V, V _{IN(–)} = 0 V, V+ = 15 V, V _O = 2 V		25°C	20	40		mA
I _{sink}	Output sink current	V _{IN(–)} = 1 V, V _{IN(+)} = 0 V, V+ = 15 V	V _O = 2 V	25°C		10	20	mA
			V _O = 200 mV			12	50	μA
αV _{IO}	Input offset voltage drift	R _S = 0 Ω		0°C to 70°C		7		μV/°C
αI _{IO}	Input offset current drift	R _S = 0 Ω		0°C to 70°C		10		pA/°C

Electrical Characteristics, Comparator Only
 $V_+ = 5\text{ V}$ (unless otherwise noted)

PARAMETER		TEST CONDITIONS	T_A	MIN	TYP	MAX	UNIT
V_G	Voltage gain	$R_L \geq 15\text{ k}\Omega$, $V_+ = 15\text{ V}$	25°C	50	200		V/mV
t_{LSR}	Large signal response time	$V_{IN} = \text{TTL logic swing}$, $V_{REF} = 1.4\text{ V}$, $V_{RL} = 5\text{ V}$, $R_L = 5.1\text{ k}\Omega$	25°C		300		ns
t_R	Response time	$V_{RL} = 5\text{ V}$, $R_L = 5.1\text{ k}\Omega$	25°C		1.3		μs
I_{SINK}	Output sink current	$V_{IN(-)} = 1\text{ V}$, $V_{IN(+)} = 0\text{ V}$, $V_O \geq 1.5\text{ V}$	25°C	6	16		mA
V_S	Saturation voltage	$V_{IN(-)} \geq 1\text{ V}$, $V_{IN(+)} = 0$, $I_{SINK} \leq 4\text{ mA}$	25°C		250	400	mV
			0°C to 70°C			700	
I_{LO}	Output leakage current	$V_{IN(-)} = 0$, $V_{IN(+)} \geq 1\text{ V}$	$V_O = 5\text{ V}$	25°C		0.1	nA
			$V_O = 30\text{ V}$	0°C to 70°C			1

PACKAGING INFORMATION

Orderable Device	Status ⁽¹⁾	Package Type	Package Drawing	Pins	Package Qty	Eco Plan ⁽²⁾	Lead/Ball Finish	MSL Peak Temp ⁽³⁾
LM392D	ACTIVE	SOIC	D	8	75	Green (RoHS & no Sb/Br)	CU NIPDAU	Level-1-260C-UNLIM
LM392DG4	ACTIVE	SOIC	D	8	75	Green (RoHS & no Sb/Br)	CU NIPDAU	Level-1-260C-UNLIM
LM392DGKR	ACTIVE	MSOP	DGK	8	2500	Green (RoHS & no Sb/Br)	CU NIPDAU	Level-1-260C-UNLIM
LM392DGKRG4	ACTIVE	MSOP	DGK	8	2500	Green (RoHS & no Sb/Br)	CU NIPDAU	Level-1-260C-UNLIM
LM392DGKT	ACTIVE	MSOP	DGK	8	250	Green (RoHS & no Sb/Br)	CU NIPDAU	Level-1-260C-UNLIM
LM392DGKTG4	ACTIVE	MSOP	DGK	8	250	Green (RoHS & no Sb/Br)	CU NIPDAU	Level-1-260C-UNLIM
LM392DR	ACTIVE	SOIC	D	8	2500	Green (RoHS & no Sb/Br)	CU NIPDAU	Level-1-260C-UNLIM
LM392DRG4	ACTIVE	SOIC	D	8	2500	Green (RoHS & no Sb/Br)	CU NIPDAU	Level-1-260C-UNLIM
LM392P	ACTIVE	PDIP	P	8	50	Pb-Free (RoHS)	CU NIPDAU	N / A for Pkg Type
LM392PE4	ACTIVE	PDIP	P	8	50	Pb-Free (RoHS)	CU NIPDAU	N / A for Pkg Type

⁽¹⁾ The marketing status values are defined as follows:

ACTIVE: Product device recommended for new designs.

LIFEBUY: TI has announced that the device will be discontinued, and a lifetime-buy period is in effect.

NRND: Not recommended for new designs. Device is in production to support existing customers, but TI does not recommend using this part in a new design.

PREVIEW: Device has been announced but is not in production. Samples may or may not be available.

OBSELETE: TI has discontinued the production of the device.

⁽²⁾ Eco Plan - The planned eco-friendly classification: Pb-Free (RoHS), Pb-Free (RoHS Exempt), or Green (RoHS & no Sb/Br) - please check <http://www.ti.com/productcontent> for the latest availability information and additional product content details.

TBD: The Pb-Free/Green conversion plan has not been defined.

Pb-Free (RoHS): TI's terms "Lead-Free" or "Pb-Free" mean semiconductor products that are compatible with the current RoHS requirements for all 6 substances, including the requirement that lead not exceed 0.1% by weight in homogeneous materials. Where designed to be soldered at high temperatures, TI Pb-Free products are suitable for use in specified lead-free processes.

Pb-Free (RoHS Exempt): This component has a RoHS exemption for either 1) lead-based flip-chip solder bumps used between the die and package, or 2) lead-based die adhesive used between the die and leadframe. The component is otherwise considered Pb-Free (RoHS compatible) as defined above.

Green (RoHS & no Sb/Br): TI defines "Green" to mean Pb-Free (RoHS compatible), and free of Bromine (Br) and Antimony (Sb) based flame retardants (Br or Sb do not exceed 0.1% by weight in homogeneous material)

⁽³⁾ MSL, Peak Temp. -- The Moisture Sensitivity Level rating according to the JEDEC industry standard classifications, and peak solder temperature.

Important Information and Disclaimer: The information provided on this page represents TI's knowledge and belief as of the date that it is provided. TI bases its knowledge and belief on information provided by third parties, and makes no representation or warranty as to the accuracy of such information. Efforts are underway to better integrate information from third parties. TI has taken and continues to take reasonable steps to provide representative and accurate information but may not have conducted destructive testing or chemical analysis on incoming materials and chemicals. TI and TI suppliers consider certain information to be proprietary, and thus CAS numbers and other limited information may not be available for release.

In no event shall TI's liability arising out of such information exceed the total purchase price of the TI part(s) at issue in this document sold by TI to Customer on an annual basis.

TAPE AND REEL INFORMATION

QUADRANT ASSIGNMENTS FOR PIN 1 ORIENTATION IN TAPE

*All dimensions are nominal

Device	Package Type	Package Drawing	Pins	SPQ	Reel Diameter (mm)	Reel Width W1 (mm)	A0 (mm)	B0 (mm)	K0 (mm)	P1 (mm)	W (mm)	Pin1 Quadrant
LM392DGKR	MSOP	DGK	8	2500	330.0	12.4	5.3	3.4	1.4	8.0	12.0	Q1
LM392DR	SOIC	D	8	2500	330.0	12.4	6.4	5.2	2.1	8.0	12.0	Q1

TAPE AND REEL BOX DIMENSIONS



*All dimensions are nominal

Device	Package Type	Package Drawing	Pins	SPQ	Length (mm)	Width (mm)	Height (mm)
LM392DGKR	MSOP	DGK	8	2500	358.0	335.0	35.0
LM392DR	SOIC	D	8	2500	340.5	338.1	20.6

P (R-PDIP-T8)

PLASTIC DUAL-IN-LINE PACKAGE

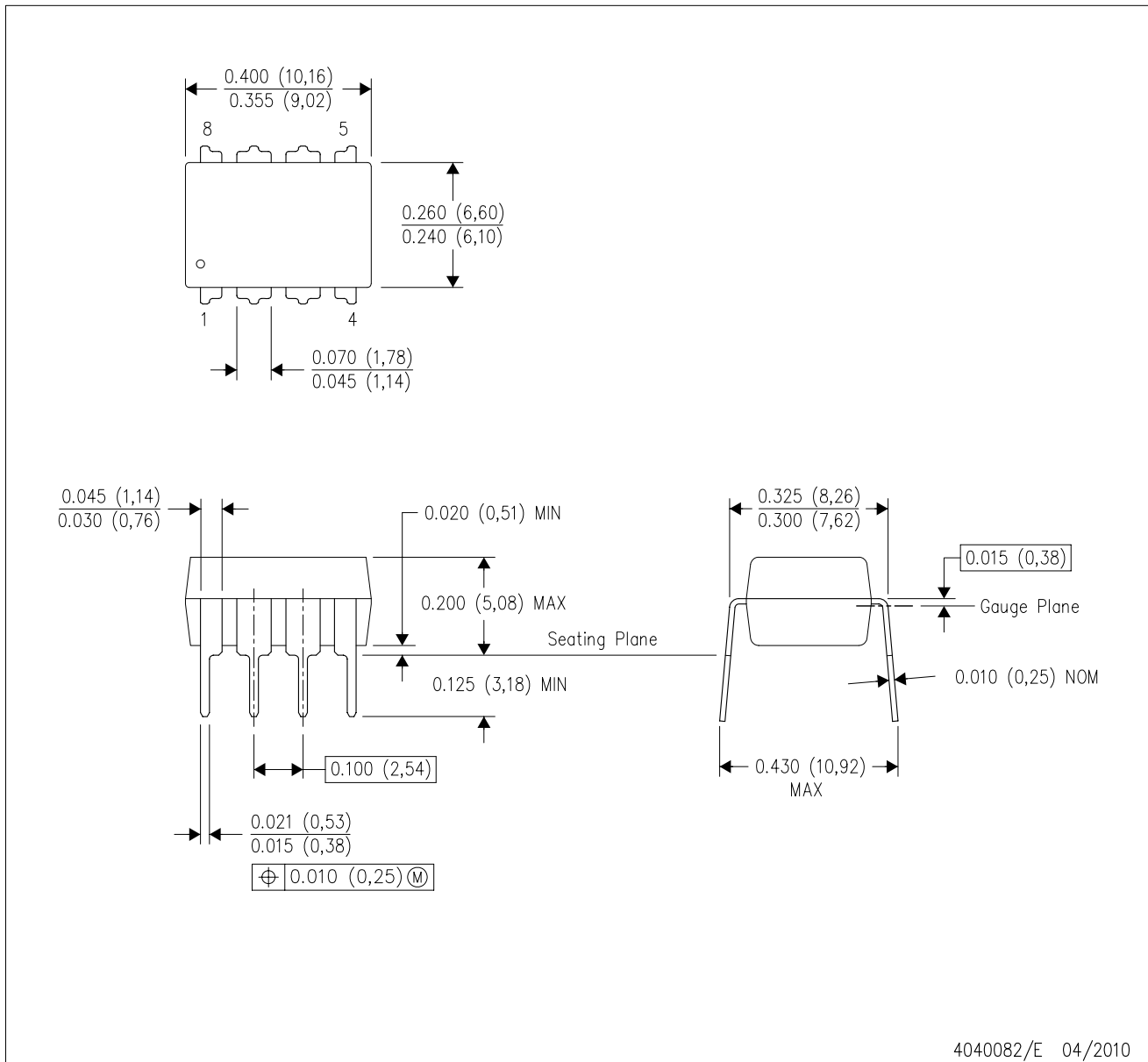

4040082/E 04/2010

- NOTES:
- A. All linear dimensions are in inches (millimeters).
 - B. This drawing is subject to change without notice.
 - C. Falls within JEDEC MS-001 variation BA.

DGK (S-PDSO-G8)

PLASTIC SMALL-OUTLINE PACKAGE

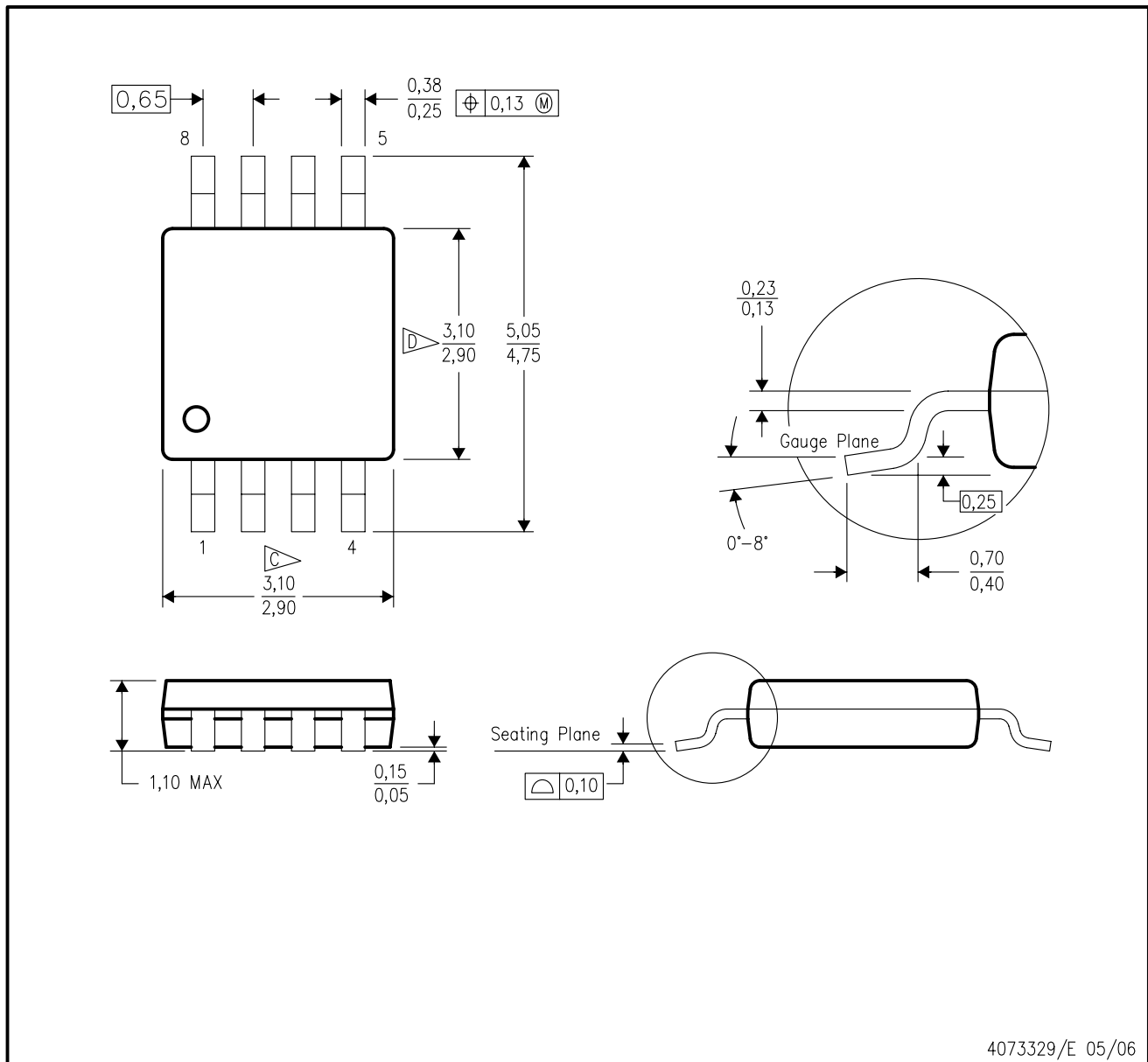

- NOTES:
- A. All linear dimensions are in millimeters.
 - B. This drawing is subject to change without notice.
 - C. Body length does not include mold flash, protrusions, or gate burrs. Mold flash, protrusions, or gate burrs shall not exceed 0.15 per end.
 - D. Body width does not include interlead flash. Interlead flash shall not exceed 0.50 per side.
 - E. Falls within JEDEC MO-187 variation AA, except interlead flash.

D (R-PDSO-G8)

PLASTIC SMALL OUTLINE

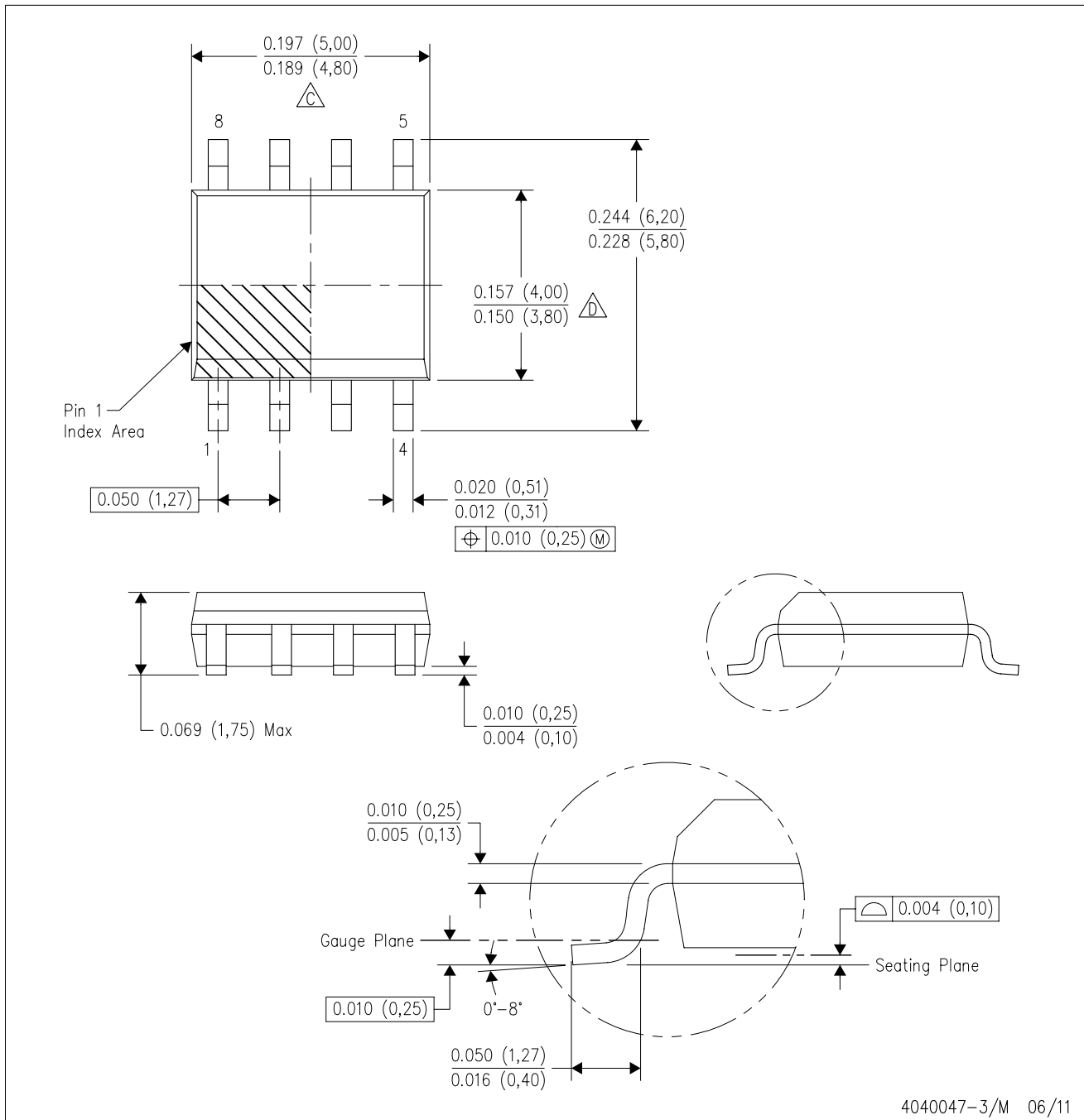

NOTES: A. All linear dimensions are in inches (millimeters).
 B. This drawing is subject to change without notice.
 C. Body length does not include mold flash, protrusions, or gate burrs. Mold flash, protrusions, or gate burrs shall not exceed 0.006 (0,15) each side.
 D. Body width does not include interlead flash. Interlead flash shall not exceed 0.017 (0,43) each side.
 E. Reference JEDEC MS-012 variation AA.

D (R-PDSO-G8)

PLASTIC SMALL OUTLINE

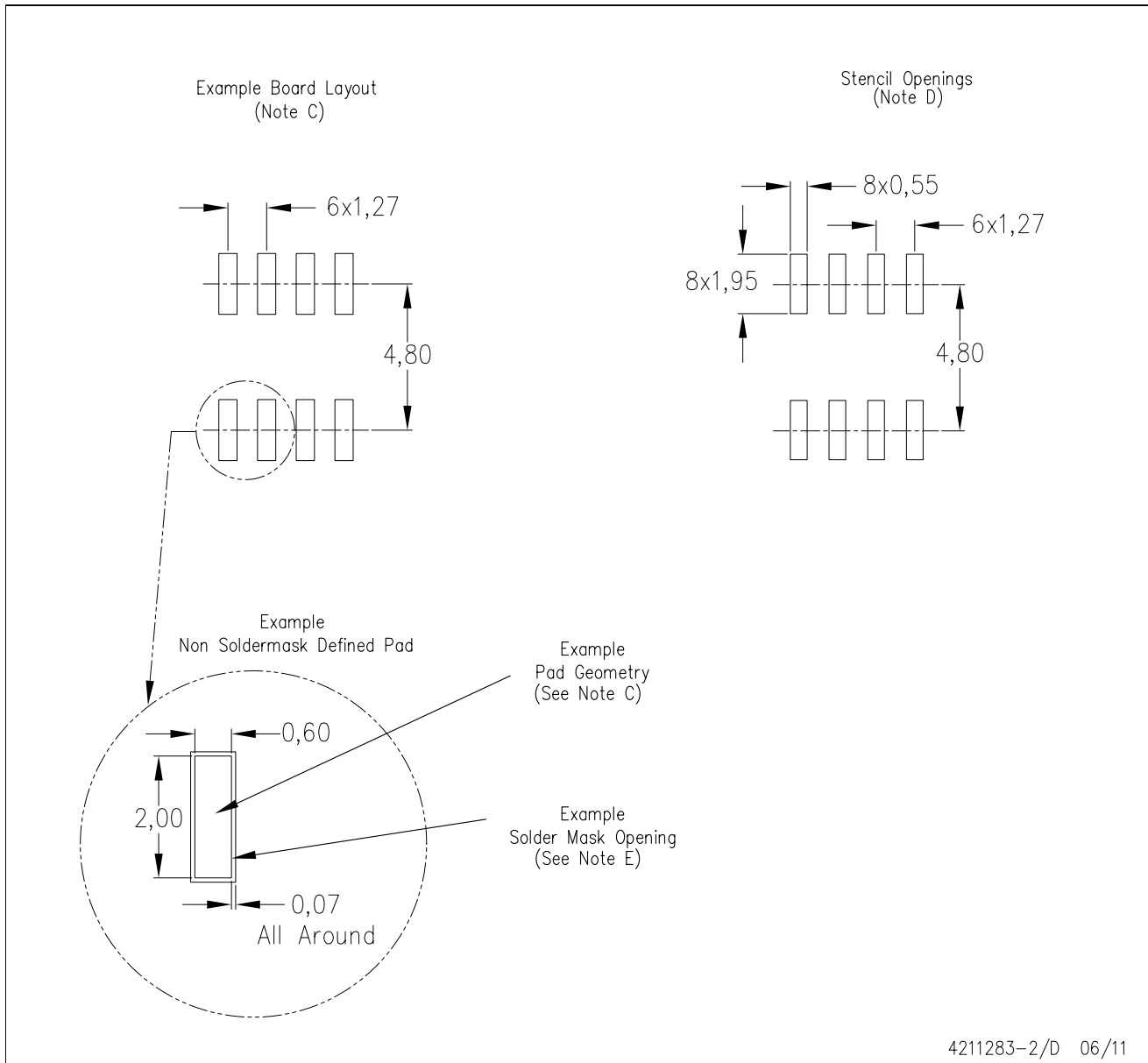

- NOTES:
- All linear dimensions are in millimeters.
 - This drawing is subject to change without notice.
 - Publication IPC-7351 is recommended for alternate designs.
 - Laser cutting apertures with trapezoidal walls and also rounding corners will offer better paste release. Customers should contact their board assembly site for stencil design recommendations. Refer to IPC-7525 for other stencil recommendations.
 - Customers should contact their board fabrication site for solder mask tolerances between and around signal pads.

IMPORTANT NOTICE

Texas Instruments Incorporated and its subsidiaries (TI) reserve the right to make corrections, modifications, enhancements, improvements, and other changes to its products and services at any time and to discontinue any product or service without notice. Customers should obtain the latest relevant information before placing orders and should verify that such information is current and complete. All products are sold subject to TI's terms and conditions of sale supplied at the time of order acknowledgment.

TI warrants performance of its hardware products to the specifications applicable at the time of sale in accordance with TI's standard warranty. Testing and other quality control techniques are used to the extent TI deems necessary to support this warranty. Except where mandated by government requirements, testing of all parameters of each product is not necessarily performed.

TI assumes no liability for applications assistance or customer product design. Customers are responsible for their products and applications using TI components. To minimize the risks associated with customer products and applications, customers should provide adequate design and operating safeguards.

TI does not warrant or represent that any license, either express or implied, is granted under any TI patent right, copyright, mask work right, or other TI intellectual property right relating to any combination, machine, or process in which TI products or services are used. Information published by TI regarding third-party products or services does not constitute a license from TI to use such products or services or a warranty or endorsement thereof. Use of such information may require a license from a third party under the patents or other intellectual property of the third party, or a license from TI under the patents or other intellectual property of TI.

Reproduction of TI information in TI data books or data sheets is permissible only if reproduction is without alteration and is accompanied by all associated warranties, conditions, limitations, and notices. Reproduction of this information with alteration is an unfair and deceptive business practice. TI is not responsible or liable for such altered documentation. Information of third parties may be subject to additional restrictions.

Resale of TI products or services with statements different from or beyond the parameters stated by TI for that product or service voids all express and any implied warranties for the associated TI product or service and is an unfair and deceptive business practice. TI is not responsible or liable for any such statements.

TI products are not authorized for use in safety-critical applications (such as life support) where a failure of the TI product would reasonably be expected to cause severe personal injury or death, unless officers of the parties have executed an agreement specifically governing such use. Buyers represent that they have all necessary expertise in the safety and regulatory ramifications of their applications, and acknowledge and agree that they are solely responsible for all legal, regulatory and safety-related requirements concerning their products and any use of TI products in such safety-critical applications, notwithstanding any applications-related information or support that may be provided by TI. Further, Buyers must fully indemnify TI and its representatives against any damages arising out of the use of TI products in such safety-critical applications.

TI products are neither designed nor intended for use in military/aerospace applications or environments unless the TI products are specifically designated by TI as military-grade or "enhanced plastic." Only products designated by TI as military-grade meet military specifications. Buyers acknowledge and agree that any such use of TI products which TI has not designated as military-grade is solely at the Buyer's risk, and that they are solely responsible for compliance with all legal and regulatory requirements in connection with such use.

TI products are neither designed nor intended for use in automotive applications or environments unless the specific TI products are designated by TI as compliant with ISO/TS 16949 requirements. Buyers acknowledge and agree that, if they use any non-designated products in automotive applications, TI will not be responsible for any failure to meet such requirements.

Following are URLs where you can obtain information on other Texas Instruments products and application solutions:

Products

Audio	www.ti.com/audio
Amplifiers	amplifier.ti.com
Data Converters	dataconverter.ti.com
DLP® Products	www.dlp.com
DSP	dsp.ti.com
Clocks and Timers	www.ti.com/clocks
Interface	interface.ti.com
Logic	logic.ti.com
Power Mgmt	power.ti.com
Microcontrollers	microcontroller.ti.com
RFID	www.ti-rfid.com
RF/IF and ZigBee® Solutions	www.ti.com/lprf

Applications

Communications and Telecom	www.ti.com/communications
Computers and Peripherals	www.ti.com/computers
Consumer Electronics	www.ti.com/consumer-apps
Energy and Lighting	www.ti.com/energy
Industrial	www.ti.com/industrial
Medical	www.ti.com/medical
Security	www.ti.com/security
Space, Avionics and Defense	www.ti.com/space-avionics-defense
Transportation and Automotive	www.ti.com/automotive
Video and Imaging	www.ti.com/video
Wireless	www.ti.com/wireless-apps

TI E2E Community Home Page

e2e.ti.com

Mailing Address: Texas Instruments, Post Office Box 655303, Dallas, Texas 75265
Copyright © 2011, Texas Instruments Incorporated

www.BDTIC.com/TI