



## 具有待机模式的 **20MHz**、低噪声、**1.8V**、**RR/I/O**、**CMOS** 运算放大器

 查询样品: [OPA322](#), [OPA322S](#), [OPA2322](#), [OPA2322S](#), [OPA4322](#), [OPA4322S](#)

### 特性

- 增益带宽: **20MHz**
- 低噪声:  **$8.5\text{nV}/\sqrt{\text{Hz}}$**  (在 **1kHz** 频率条件下)
- 转换速率: **10V/ $\mu\text{s}$**
- 低 **THD + N**: **0.0005%**
- 轨至轨输入输出 (**I/O**)
- 失调电压: **2mV** (最大值)
- 电源电压: **1.8V 至 5.5V**
- 电源电流: 每通道 **1.5mA**
  - 待机模式: 每个通道的静态电流为 **0.1 $\mu\text{A}$**
- 具有稳定的单位增益
- 小外形封装:
  - **SOT23, DFN, MSOP, TSSOP**

### 应用

- 传感器信号调节
- 消费类音频
- 多极点有源滤波器
- 控制环路放大器
- 通信
- 安全
- 扫描仪

### 说明

OPA322 系列包含具有低噪声和轨至轨输入/输出的单通道、双通道和四通道 CMOS 运算放大器, 专为低功耗、单电源应用而优化。1.8V 至 5.5V 的宽电源范围以及每通道仅 1.5mA 的低静态电流, 使得这些器件非常适合于功耗敏感型应用。

由于兼具超低的噪声 (在 1kHz 频率下为  $8.5\text{nV}/\sqrt{\text{Hz}}$ )、高的增益带宽 (20MHz) 和高转换速率 (10V/ $\mu\text{s}$ ), 因而使得 OPA322 系列成为众多应用的理想选择, 包括信号调节及需要高增益的传感器放大。另外, OPA322 系列还拥有很低的 THD + N, 因此同样极为适合于消费类音频应用, 尤其是单电源系统。

OPAy322S 型号的器件具有一种待机模式, 该模式允许将放大器从正常操作状态切换至待机状态 (待机电流通常小于 0.1 $\mu\text{A}$ )。

OPA322 (单通道版本) 采用 SOT23-5 和 SOT23-6 封装, 而 OPA2322 (双通道版本) 则可提供 MSOP-8、MSOP-10、SO-8 和 DFN-8 封装。四通道版本 OPA4322 采用 TSSOP-14 和 TSSOP-16 封装。所有器件版本的规定工作温度范围均为  $-40^{\circ}\text{C}$  至  $+125^{\circ}\text{C}$



Please be aware that an important notice concerning availability, standard warranty, and use in critical applications of Texas Instruments semiconductor products and disclaimers thereto appears at the end of this data sheet.

FilterPro is a trademark of Texas Instruments Incorporated.

All other trademarks are the property of their respective owners.

UNLESS OTHERWISE NOTED this document contains PRODUCTION DATA information current as of publication date. Products conform to specifications in the datasheet on Texas Instruments standard warranty. Production processing does not necessarily include testing of all parameters.

Copyright © 2011 年 2011 – Texas Instruments Incorporated  
English Data Sheet: [SBOS538A](#)

[www.BDTIC.com/TI](http://www.BDTIC.com/TI)



This integrated circuit can be damaged by ESD. Texas Instruments recommends that all integrated circuits be handled with appropriate precautions. Failure to observe proper handling and installation procedures can cause damage.

ESD damage can range from subtle performance degradation to complete device failure. Precision integrated circuits may be more susceptible to damage because very small parametric changes could cause the device not to meet its published specifications.

### PACKAGE/ORDERING INFORMATION<sup>(1)</sup>

PRODUCT	PACKAGE-LEAD	PACKAGE DESIGNATOR	PACKAGE MARKING
OPA322 <sup>(2)</sup>	SOT23-5	DBV	RAD
OPA322S <sup>(2)</sup>	SOT23-6	DBV	RAF
OPA2322 <sup>(2)</sup>	SO-8	D	O2322A
OPA2322	MSOP-8	DGK	OOZI
	DFN-8	DRG	OPCI
OPA2322S <sup>(2)</sup>	MSOP-10	DGS	OPBI
OPA4322 <sup>(2)</sup>	TSSOP-14	PW	OPA4322
OPA4322S <sup>(2)</sup>	TSSOP-16	PW	OPA4322S

- (1) For the most current package and ordering information, see the Package Option Addendum located at the end of this data sheet, or visit the device product folder at [www.ti.com](http://www.ti.com).  
 (2) Product preview device.

### ABSOLUTE MAXIMUM RATINGS<sup>(1)</sup>

Over operating free-air temperature range, unless otherwise noted.

		OPA322, OPA322S, OPA2322, OPA2322S, OPA4322, OPA4322S	UNIT
Supply voltage, $V_S = (V+) - (V-)$		6	V
Signal input pins	Voltage <sup>(2)</sup>	$(V-) - 0.5$ to $(V+) + 0.5$	V
	Current <sup>(2)</sup>	$\pm 10$	mA
Output short-circuit current <sup>(3)</sup>		Continuous	mA
Operating temperature, $T_A$		-40 to +150	°C
Storage temperature, $T_{stg}$		-65 to +150	°C
Junction temperature, $T_J$		+150	°C
ESD ratings	Human body model (HBM)	4000	V
	Charged device model (CDM)	1000	V
	Machine model (MM)	200	V

- (1) Stresses above these ratings may cause permanent damage. Exposure to absolute maximum conditions for extended periods may degrade device reliability. These are stress ratings only, and functional operation of the device at these or any other conditions beyond those specified is not implied.  
 (2) Input terminals are diode-clamped to the power-supply rails. Input signals that can swing more than 0.5 V beyond the supply rails should be current limited to 10 mA or less.  
 (3) Short-circuit to ground, one amplifier per package.

**ELECTRICAL CHARACTERISTICS:  $V_S = +1.8\text{ V}$  to  $+5.5\text{ V}$ , or  $\pm 0.9\text{ V}$  to  $\pm 2.75\text{ V}$** 
**Boldface** limits apply over the specified temperature range,  $T_A = -40^\circ\text{C}$  to  $+125^\circ\text{C}$ .

 At  $T_A = +25^\circ\text{C}$ ,  $R_L = 10\text{ k}\Omega$  connected to  $V_S/2$ ,  $V_{CM} = V_S/2$ ,  $V_{OUT} = V_S/2$ , and  $\text{SHDN}_X = V_S+$ , unless otherwise noted.

PARAMETER	TEST CONDITIONS	OPA322, OPA322S, OPA2322, OPA2322S, OPA4322, OPA4322S			UNIT
		MIN	TYP	MAX	
<b>OFFSET VOLTAGE</b>					
Input offset voltage	$V_{OS}$		0.5	2	mV
<b>vs Temperature</b>	$dV_{OS}/dT$	$V_S = +5.5\text{ V}$	<b>1.8</b>	<b>6</b>	$\mu\text{V}/^\circ\text{C}$
vs Power supply	PSR	$V_S = +1.8\text{ V}$ to $+5.5\text{ V}$	10	50	$\mu\text{V}/\text{V}$
<b>Over temperature</b>		$V_S = +1.8\text{ V}$ to $+5.5\text{ V}$	<b>20</b>	<b>65</b>	$\mu\text{V}/\text{V}$
Channel separation	At 1 kHz		130		dB
<b>INPUT VOLTAGE</b>					
Common-mode voltage range	$V_{CM}$		$(V-) - 0.1$	$(V+) + 0.1$	V
Common-mode rejection ratio	CMRR	$(V-) - 0.1\text{ V} < V_{CM} < (V+) + 0.1\text{ V}$	90	100	dB
<b>Over temperature</b>			<b>90</b>		<b>dB</b>
<b>INPUT BIAS CURRENT</b>					
Input bias current	$I_B$		$\pm 0.2$	$\pm 10$	pA
<b>Over temperature</b>		$T_A = -40^\circ\text{C}$ to $+85^\circ\text{C}$		$\pm 50$	<b>pA</b>
		$T_A = -40^\circ\text{C}$ to $+125^\circ\text{C}$		$\pm 400$	<b>pA</b>
Input offset current	$I_{OS}$		$\pm 0.2$	$\pm 10$	pA
<b>Over temperature</b>		$T_A = -40^\circ\text{C}$ to $+85^\circ\text{C}$		$\pm 50$	<b>pA</b>
		$T_A = -40^\circ\text{C}$ to $+125^\circ\text{C}$		$\pm 400$	<b>pA</b>
<b>NOISE</b>					
Input voltage noise		$f = 0.1\text{ Hz}$ to $10\text{ Hz}$		2.8	$\mu\text{V}_{PP}$
Input voltage noise density	$e_n$	$f = 1\text{ kHz}$		8.5	$\text{nV}/\sqrt{\text{Hz}}$
		$f = 10\text{ kHz}$		7	$\text{nV}/\sqrt{\text{Hz}}$
Input current noise density	$i_n$	$f = 1\text{ kHz}$		0.6	$\text{fA}/\sqrt{\text{Hz}}$
<b>INPUT CAPACITANCE</b>					
Differential				5	pF
Common-mode				4	pF
<b>OPEN-LOOP GAIN</b>					
Open-loop voltage gain	$A_{OL}$	$0.1\text{ V} < V_O < (V+) - 0.1\text{ V}$ , $R_L = 10\text{ k}\Omega$	100	120	dB
		$0.1\text{ V} < V_O < (V+) - 0.1\text{ V}$ , $R_L = 10\text{ k}\Omega$	<b>94</b>		<b>dB</b>
Phase margin	PM	$G = 1\text{ V}/\text{V}$ , $V_S = 5\text{ V}$ , $C_L = 50\text{ pF}$		47	Degrees
<b>FREQUENCY RESPONSE</b>					
$V_S = 5.0\text{ V}$ , $C_L = 50\text{ pF}$					
Gain bandwidth product	GBP	Unity gain		20	MHz
Slew rate	SR	$G = +1$		10	$\text{V}/\mu\text{s}$
Settling time	$t_S$	To 0.1%, 2-V step, $G = +1$		0.25	$\mu\text{s}$
		To 0.01%, 2-V step, $G = +1$		0.32	$\mu\text{s}$
Overload recovery time		$V_{IN} \times G > V_S$		100	ns
Total harmonic distortion + noise <sup>(1)</sup>	THD+N	$V_O = 4\text{ V}_{PP}$ , $G = +1$ , $f = 10\text{ kHz}$ , $R_L = 10\text{ k}\Omega$		0.0005	%
		$V_O = 2\text{ V}_{PP}$ , $G = +1$ , $f = 10\text{ kHz}$ , $R_L = 600\ \Omega$		0.0011	%

(1) Third-order filter; bandwidth = 80 kHz at -3 dB.

**ELECTRICAL CHARACTERISTICS:  $V_S = +1.8\text{ V}$  to  $+5.5\text{ V}$ , or  $\pm 0.9\text{ V}$  to  $\pm 2.75\text{ V}$  (continued)**

**Boldface** limits apply over the specified temperature range,  $T_A = -40^\circ\text{C}$  to  $+125^\circ\text{C}$ .

At  $T_A = +25^\circ\text{C}$ ,  $R_L = 10\text{ k}\Omega$  connected to  $V_S/2$ ,  $V_{CM} = V_S/2$ ,  $V_{OUT} = V_S/2$ , and  $\overline{\text{SHDN}}_X = V_{S+}$ , unless otherwise noted.

PARAMETER	TEST CONDITIONS	OPA322, OPA322S, OPA2322, OPA2322S, OPA4322, OPA4322S			UNIT
		MIN	TYP	MAX	
<b>OUTPUT</b>					
Voltage output swing from both rails	$V_O$	$R_L = 10\text{ k}\Omega$	10	20	mV
<b>Over temperature</b>		<b><math>R_L = 10\text{ k}\Omega</math></b>		<b>30</b>	<b>mV</b>
Short-circuit current	$I_{SC}$	$V_S = 5.5\text{ V}$	$\pm 65$		mA
Capacitive load drive	$C_L$		See <a href="#">Typical Characteristics</a>		
Open-loop output resistance	$R_O$	$I_O = 0\text{ mA}$ , $f = 1\text{ MHz}$	90		$\Omega$
<b>POWER SUPPLY</b>					
Specified voltage range	$V_S$		1.8	5.5	V
Quiescent current per amplifier	$I_Q$	$I_O = 0\text{ mA}$ , $V_S = +5.5\text{ V}$			
OPA322, OPA322S			1.6	1.8	mA
<b>Over temperature</b>				<b>TBD</b>	<b>mA</b>
OPA2322, OPA2322S			1.5	1.75	mA
<b>Over temperature</b>				<b>1.85</b>	<b>mA</b>
OPA4322, OPA4322S			1.45	1.65	mA
<b>Over temperature</b>				<b>TBD</b>	<b>mA</b>
Power-on time		$V_{S+} = 0\text{ V}$ to $5\text{ V}$ , to 90% $I_Q$ level	28		$\mu\text{s}$
<b>SHUTDOWN<sup>(2)</sup></b>					
		$V_S = 1.8\text{ V}$ to $5.5\text{ V}$			
Quiescent current, per amplifier	$I_{QSD}$	All amplifiers disabled, $\overline{\text{SHDN}} = V_{S-}$	0.1	1	$\mu\text{A}$
OPA2322S only		$\overline{\text{SHDN}}_A = V_{S-}$ , $\overline{\text{SHDN}}_B = V_{S+}$	1.6		mA
		$\overline{\text{SHDN}}_A = V_{S+}$ , $\overline{\text{SHDN}}_B = V_{S-}$	1.6		mA
High voltage (enabled)	$V_{IH}$	Amplifier enabled	$0.7 \times V_{S+}$	5.5	V
Low voltage (disabled)	$V_{IL}$	Amplifier disabled		$0.3 \times V_{S+}$	V
Amplifier enable time <sup>(3)</sup>	$t_{ON}$	$G = 1$ , $V_{OUT} = 0.9 \times V_S/2$ , full shutdown <sup>(4)</sup>	20		$\mu\text{s}$
Amplifier enable time <sup>(3)</sup> OPA2322S only	$t_{ON}$	Partial shutdown <sup>(4)</sup>	6		$\mu\text{s}$
Amplifier disable time <sup>(3)</sup>	$t_{OFF}$	$G = 1$ , $V_{OUT} = 0.1 \times V_S/2$	3		$\mu\text{s}$
$\overline{\text{SHDN}}$ pin input bias current (per pin)		$V_{IH} = 5.0\text{ V}$	0.13		$\mu\text{A}$
		$V_{IL} = 0\text{ V}$	0.04		$\mu\text{A}$
<b>TEMPERATURE</b>					
Specified range			-40	+125	$^\circ\text{C}$
Operating range			-40	+150	$^\circ\text{C}$

(2) Ensured by design and characterization; not production tested.

(3) Disable time ( $t_{OFF}$ ) and enable time ( $t_{ON}$ ) are defined as the time interval between the 50% point of the signal applied to the  $\overline{\text{SHDN}}$  pin and the point at which the output voltage reaches the 10% (disable) or 90% (enable) level.

(4) Full shutdown refers to the dual OPA2322S having both channels A and B disabled ( $\overline{\text{SHDN}}_A = \overline{\text{SHDN}}_B = V_{S-}$ ) and the quad OPA4322S having all channels A to D disabled ( $\overline{\text{SHDN}}_A/B = \overline{\text{SHDN}}_C/D = V_{S-}$ ). For partial shutdown, only one  $\overline{\text{SHDN}}$  pin is exercised; in this mode, the internal biasing and oscillator remain operational and the enable time is shorter.

**THERMAL INFORMATION**

THERMAL METRIC <sup>(1)</sup>		OPA322	OPA322S	UNITS
		DBV	DBV	
		5 PINS	6 PINS	
$\theta_{JA}$	Junction-to-ambient thermal resistance	219.3	TBD	°C/W
$\theta_{JC(top)}$	Junction-to-case(top) thermal resistance	107.5	TBD	
$\theta_{JB}$	Junction-to-board thermal resistance	57.5	TBD	
$\Psi_{JT}$	Junction-to-top characterization parameter	7.4	TBD	
$\Psi_{JB}$	Junction-to-board characterization parameter	56.9	TBD	
$\theta_{JC(bottom)}$	Junction-to-case(bottom) thermal resistance	n/a	TBD	

(1) 有关传统和新的热度的更多信息，请参阅 IC 封装热量量 应用报告 [SPRA953](#)。

**THERMAL INFORMATION**

THERMAL METRIC <sup>(1)</sup>		OPA2322			OPA2322S	UNITS
		D	DRG	DGK	DGS	
		8 PINS	8 PINS	8 PINS	10 PINS	
$\theta_{JA}$	Junction-to-ambient thermal resistance	122.6	50.6	174.8	TBD	°C/W
$\theta_{JC(top)}$	Junction-to-case(top) thermal resistance	67.1	54.9	43.9	TBD	
$\theta_{JB}$	Junction-to-board thermal resistance	64.0	25.2	95.0	TBD	
$\Psi_{JT}$	Junction-to-top characterization parameter	13.2	0.6	2.0	TBD	
$\Psi_{JB}$	Junction-to-board characterization parameter	63.4	25.3	93.5	TBD	
$\theta_{JC(bottom)}$	Junction-to-case(bottom) thermal resistance	n/a	5.7	n/a	TBD	

(1) 有关传统和新的热度的更多信息，请参阅 IC 封装热量量 应用报告 [SPRA953](#)。

**THERMAL INFORMATION**

THERMAL METRIC <sup>(1)</sup>		OPA4322	OPA4322S	UNITS
		PW	PW	
		14 PINS	16 PINS	
$\theta_{JA}$	Junction-to-ambient thermal resistance	109.8	TBD	°C/W
$\theta_{JC(top)}$	Junction-to-case(top) thermal resistance	34.9	TBD	
$\theta_{JB}$	Junction-to-board thermal resistance	52.5	TBD	
$\Psi_{JT}$	Junction-to-top characterization parameter	2.2	TBD	
$\Psi_{JB}$	Junction-to-board characterization parameter	51.8	TBD	
$\theta_{JC(bottom)}$	Junction-to-case(bottom) thermal resistance	n/a	TBD	

(1) 有关传统和新的热度的更多信息，请参阅 IC 封装热量量 应用报告 [SPRA953](#)。

## PIN CONFIGURATIONS

**DBV PACKAGE**  
**SOT23-5**  
**(TOP VIEW)**

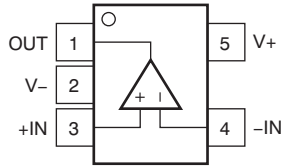

**DBV PACKAGE**  
**SOT23-6**  
**(TOP VIEW)**

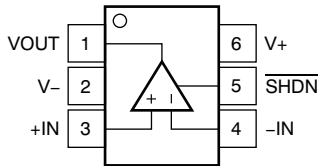

**DGS PACKAGE**  
**MSOP-10**  
**(TOP VIEW)**

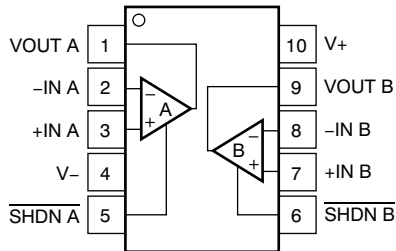

**D, DGK PACKAGES**  
**SO-8, MSOP-8**  
**(TOP VIEW)**

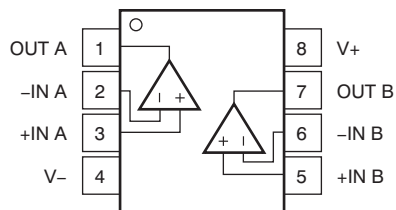

**DRG PACKAGE<sup>(1)(2)</sup>**  
**DFN-8**  
**(TOP VIEW)**

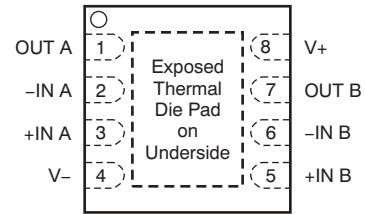

**PW PACKAGE**  
**TSSOP-14**  
**(TOP VIEW)**

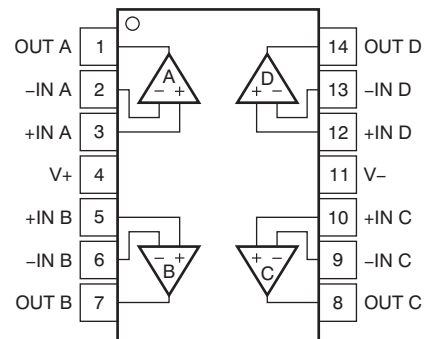

**PW PACKAGE**  
**TSSOP-16**  
**(TOP VIEW)**

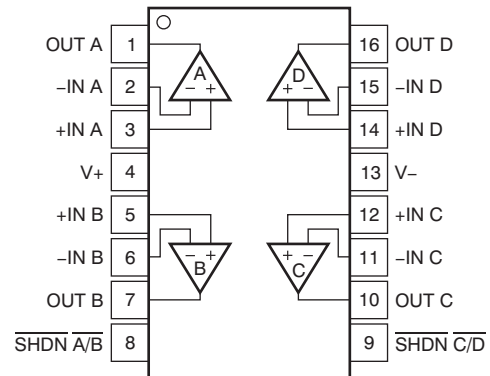

- (1) Connect thermal pad to V-.
- (2) Pad size: 2mm × 1.2mm.

### TYPICAL CHARACTERISTICS

At  $T_A = +25^\circ\text{C}$ ,  $V_{CM} = V_{OUT} = \text{mid-supply}$ , and  $R_L = 10\text{ k}\Omega$ , unless otherwise noted.

**OPEN-LOOP GAIN/PHASE vs FREQUENCY**

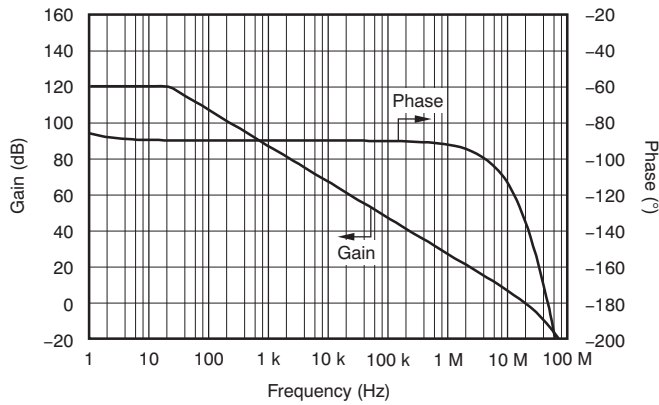

Figure 1.

**OPEN-LOOP GAIN vs TEMPERATURE**

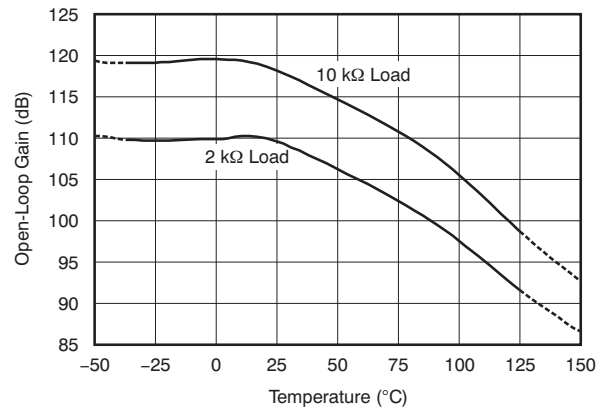

Figure 2.

**INPUT BIAS CURRENT vs SUPPLY VOLTAGE**

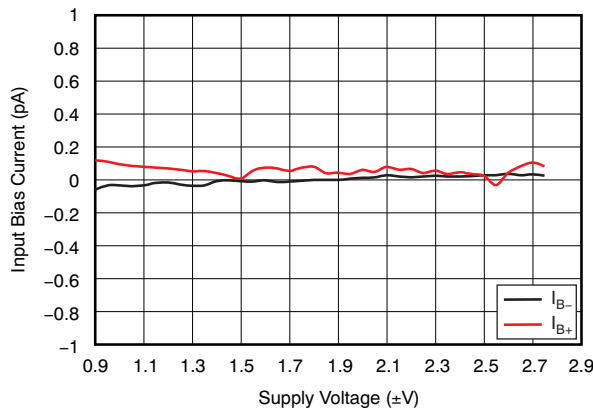

Figure 3.

**INPUT BIAS CURRENT vs COMMON-MODE VOLTAGE**

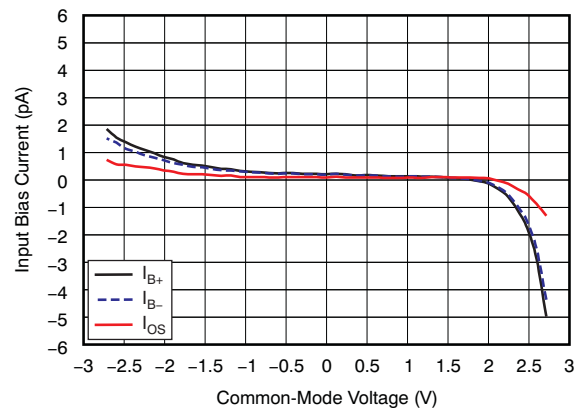

Figure 4.

**INPUT BIAS CURRENT vs TEMPERATURE**

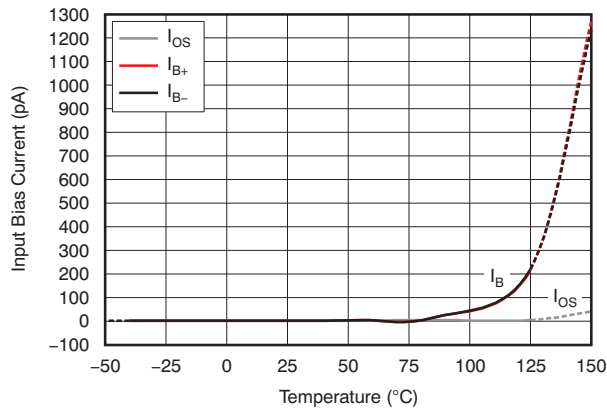

Figure 5.

**QUIESCENT CURRENT vs SUPPLY VOLTAGE**

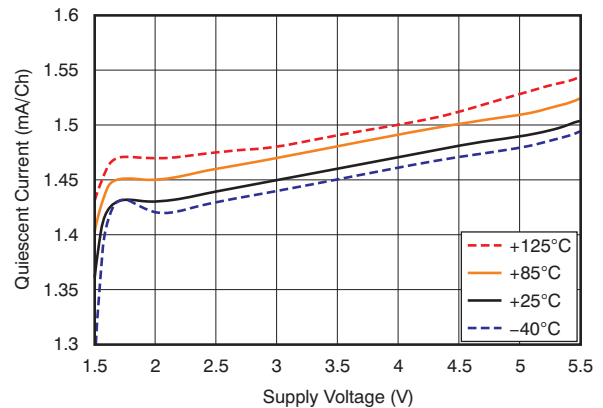

Figure 6.

**TYPICAL CHARACTERISTICS (continued)**

At  $T_A = +25^\circ\text{C}$ ,  $V_{CM} = V_{OUT} = \text{mid-supply}$ , and  $R_L = 10\text{ k}\Omega$ , unless otherwise noted.

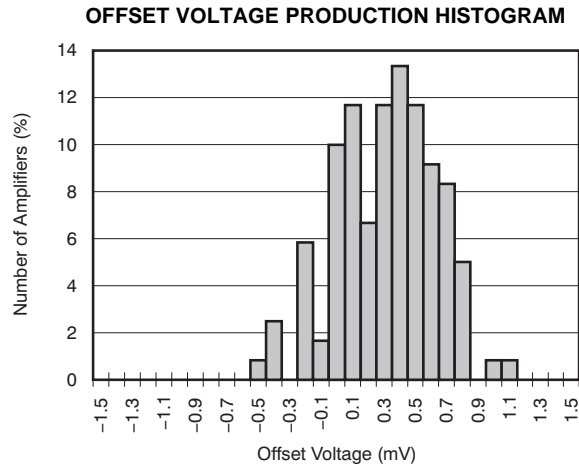

Figure 7.

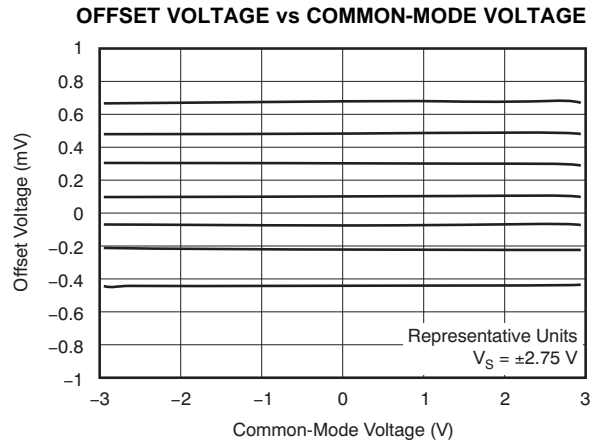

Figure 8.

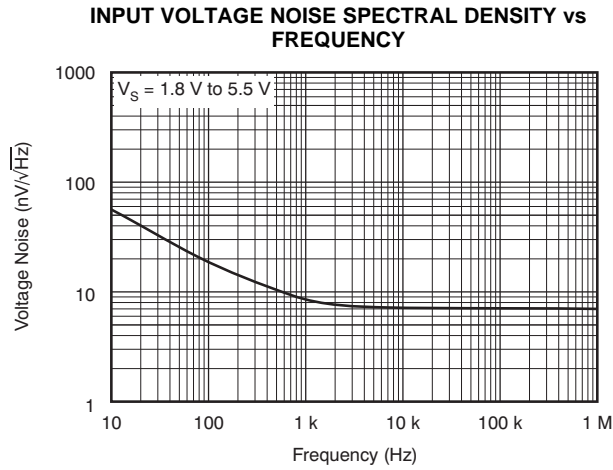

Figure 9.

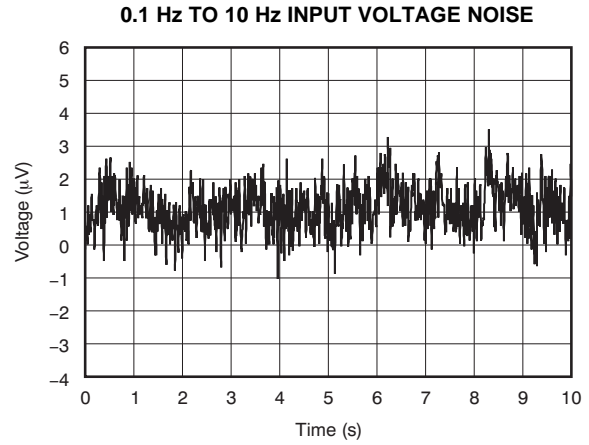

Figure 10.

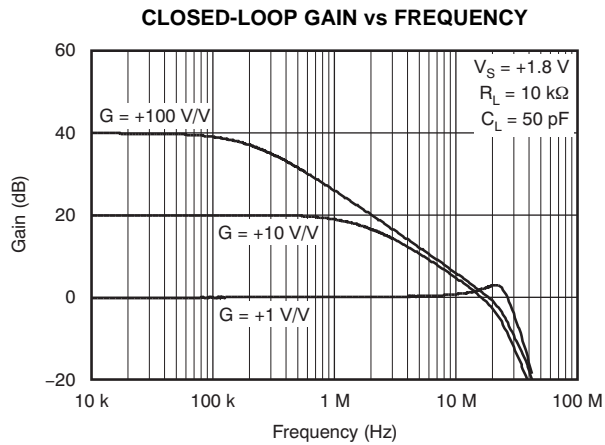

Figure 11.

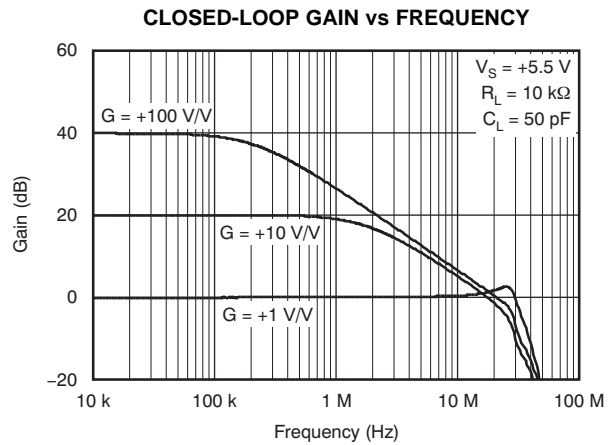

Figure 12.



TYPICAL CHARACTERISTICS (continued)

At  $T_A = +25^\circ\text{C}$ ,  $V_{CM} = V_{OUT} = \text{mid-supply}$ , and  $R_L = 10\text{ k}\Omega$ , unless otherwise noted.

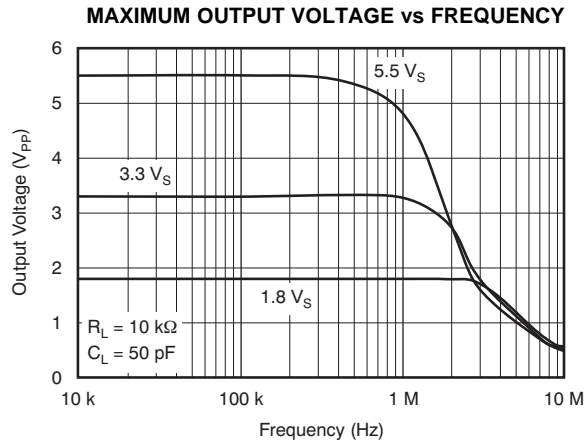

Figure 13.

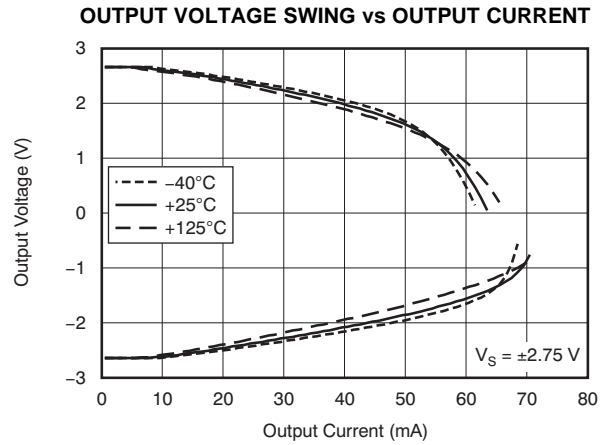

Figure 14.

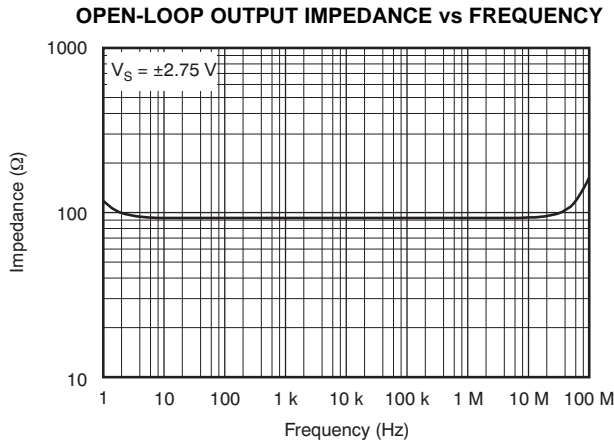

Figure 15.

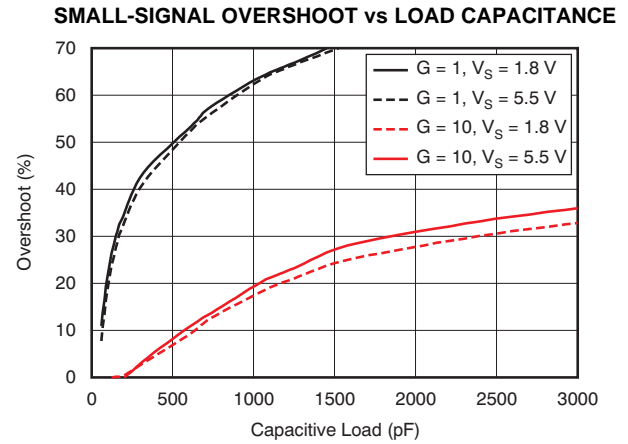

Figure 16.

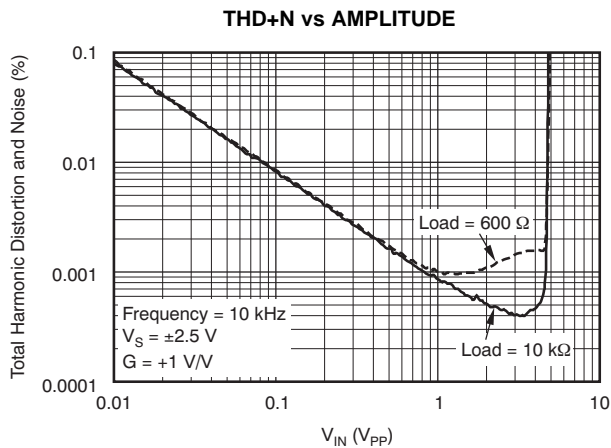

Figure 17.

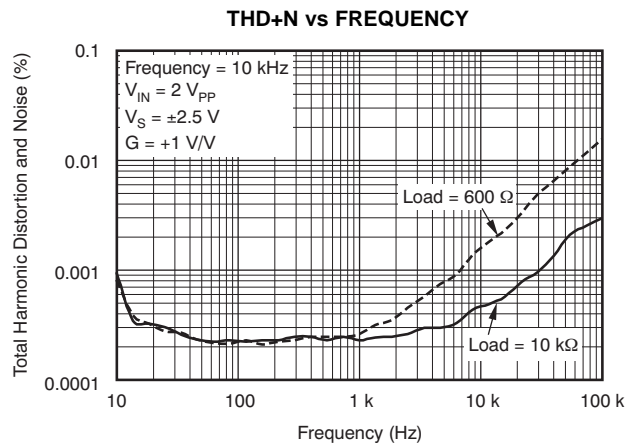

Figure 18.

**TYPICAL CHARACTERISTICS (continued)**

At  $T_A = +25^\circ\text{C}$ ,  $V_{CM} = V_{OUT} = \text{mid-supply}$ , and  $R_L = 10\text{ k}\Omega$ , unless otherwise noted.

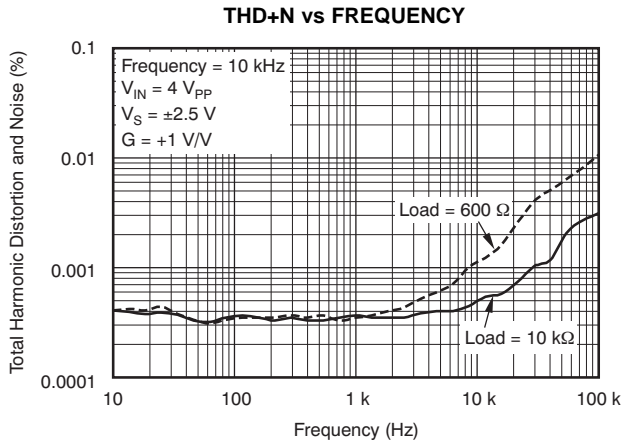

Figure 19.

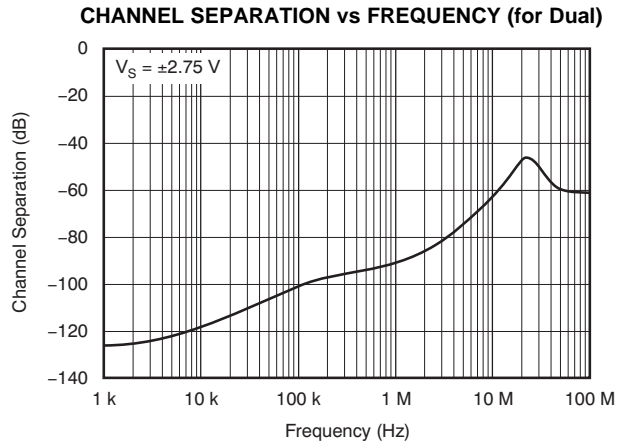

Figure 20.

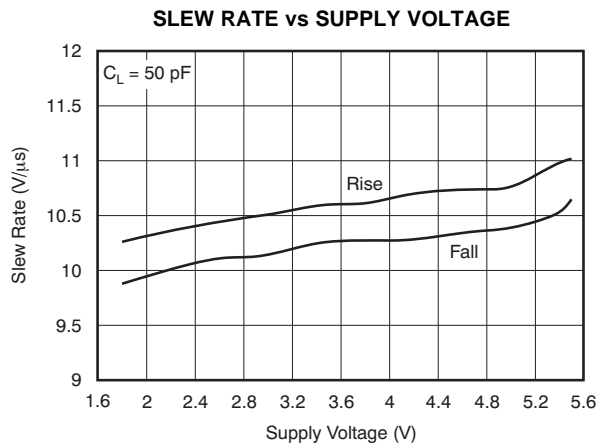

Figure 21.

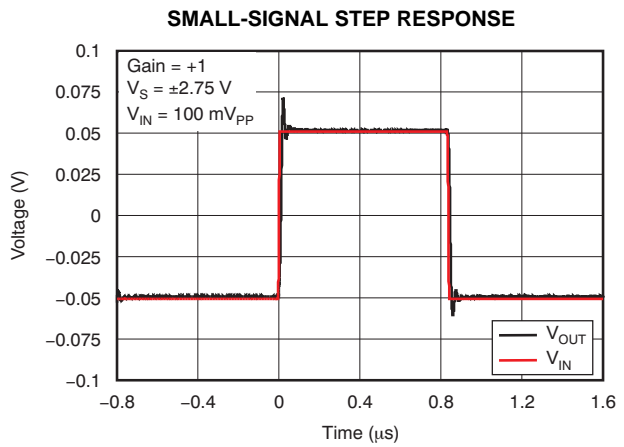

Figure 22.

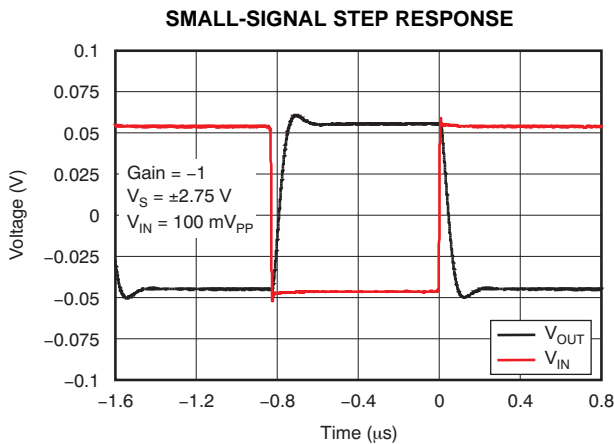

Figure 23.

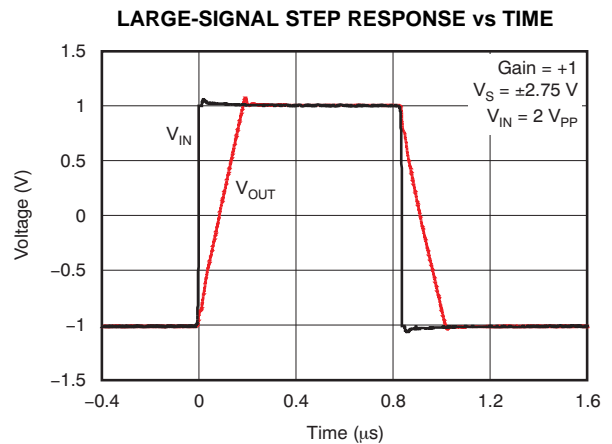

Figure 24.

## APPLICATION INFORMATION

### OPERATING VOLTAGE

The OPA322 series op amps are unity-gain stable and can operate on a single-supply voltage (1.8 V to 5.5 V), or a split-supply voltage ( $\pm 0.9$  V to  $\pm 2.75$  V), making them highly versatile and easy to use. The power-supply pins should have local bypass ceramic capacitors (typically 0.001  $\mu$ F to 0.1  $\mu$ F). These amplifiers are fully specified from +1.8 V to +5.5 V and over the extended temperature range of  $-40^{\circ}\text{C}$  to  $+125^{\circ}\text{C}$ . Parameters that can exhibit variance with regard to operating voltage or temperature are presented in the [Typical Characteristics](#).

### INPUT AND ESD PROTECTION

The OPA322 incorporates internal electrostatic discharge (ESD) protection circuits on all pins. In the case of input and output pins, this protection primarily consists of current-steering diodes connected between the input and power-supply pins. These ESD protection diodes also provide in-circuit input overdrive protection, as long as the current is limited to 10 mA as stated in the [Absolute Maximum Ratings](#) table. Many input signals are inherently current-limited to less than 10 mA; therefore, a limiting resistor is not required. [Figure 25](#) shows how a series input resistor ( $R_S$ ) may be added to the driven input to limit the input current. The added resistor contributes thermal noise at the amplifier input and the value should be kept to the minimum in noise-sensitive applications.

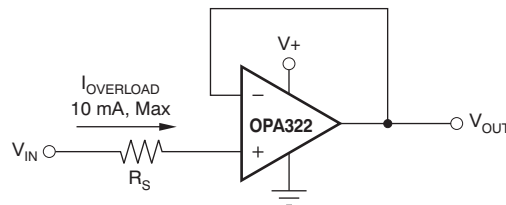

Figure 25. Input Current Protection

### PHASE REVERSAL

The OPA322 op amps are designed to be immune to phase reversal when the input pins exceed the supply voltages, therefore providing further in-system stability and predictability. [Figure 26](#) shows the input voltage exceeding the supply voltage without any phase reversal.

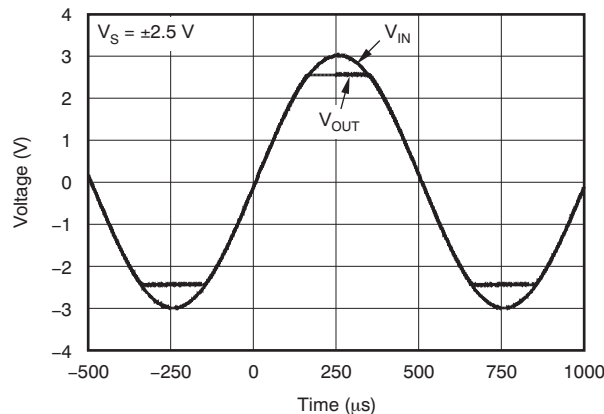
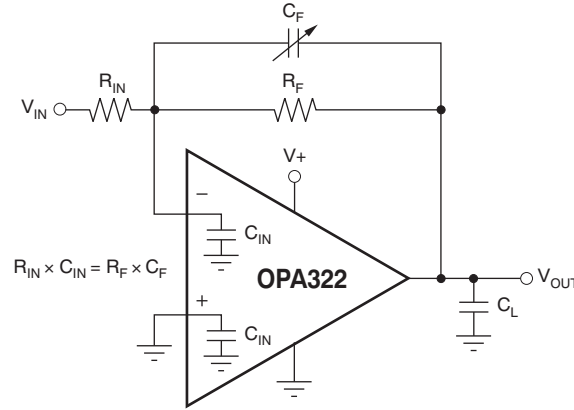

Figure 26. No Phase Reversal

## FEEDBACK CAPACITOR IMPROVES RESPONSE

For optimum settling time and stability with high-impedance feedback networks, it may be necessary to add a feedback capacitor across the feedback resistor,  $R_F$ , as shown in Figure 27. This capacitor compensates for the zero created by the feedback network impedance and the OPA322 input capacitance (and any parasitic layout capacitance). The effect becomes more significant with higher impedance networks.



NOTE: Where  $C_{IN}$  is equal to the OPA322 input capacitance (approximately 9 pF) plus any parasitic layout capacitance.

**Figure 27. Feedback Capacitor Improves Dynamic Performance**

It is suggested that a variable capacitor be used for the feedback capacitor because input capacitance may vary between op amps and layout capacitance is difficult to determine. For the circuit shown in Figure 27, the value of the variable feedback capacitor should be chosen so that the input resistance times the input capacitance of the OPA322 (typically 9 pF) plus the estimated parasitic layout capacitance equals the feedback capacitor times the feedback resistor:

$$R_{IN} \times C_{IN} = R_F \times C_F$$

Where:

$C_{IN}$  is equal to the OPA322 input capacitance (sum of differential and common-mode) plus the layout capacitance.

The capacitor value can be adjusted until optimum performance is obtained.

## EMI SUSCEPTIBILITY AND INPUT FILTERING

Operational amplifiers vary in susceptibility to electromagnetic interference (EMI). If conducted EMI enters the device, the dc offset observed at the amplifier output may shift from the nominal value while EMI is present. This shift is a result of signal rectification associated with the internal semiconductor junctions. While all operational amplifier pin functions can be affected by EMI, the input pins are likely to be the most susceptible. The OPA322 operational amplifier family incorporates an internal input low-pass filter that reduces the amplifier response to EMI. Both common-mode and differential mode filtering are provided by the input filter. The filter is designed for a cutoff frequency of approximately 580 MHz (–3 dB), with a roll-off of 20 dB per decade.

## OUTPUT IMPEDANCE

The open-loop output impedance of the OPA322 common-source output stage is approximately 90  $\Omega$ . When the op amp is connected with feedback, this value is reduced significantly by the loop gain. For each decade rise in the closed-loop gain, the loop gain is reduced by the same amount, which results in a ten-fold increase in effective output impedance. While the OPA322 output impedance remains very flat over a wide frequency range, at higher frequencies the output impedance rises as the open-loop gain of the op amp drops. However, at these frequencies the output also becomes capacitive as a result of parasitic capacitance. This characteristic, in turn, prevents the output impedance from becoming too high, which can cause stability problems when driving large capacitive loads. As mentioned previously, the OPA322 has excellent capacitive load drive capability for an op amp with its bandwidth.

## CAPACITIVE LOAD AND STABILITY

The OPA322 is designed to be used in applications where driving a capacitive load is required. As with all op amps, there may be specific instances where the OPA322 can become unstable. The particular op amp circuit configuration, layout, gain, and output loading are some of the factors to consider when establishing whether an amplifier is stable in operation. An op amp in the unity-gain (+1 V/V) buffer configuration and driving a capacitive load exhibits a greater tendency to become unstable than an amplifier operated at a higher noise gain. The capacitive load, in conjunction with the op amp output resistance, creates a pole within the feedback loop that degrades the phase margin. The degradation of the phase margin increases as the capacitive loading increases. When operating in the unity-gain configuration, the OPA322 remains stable with a pure capacitive load up to approximately 1 nF.

The equivalent series resistance (ESR) of some very large capacitors ( $C_L > 1 \mu\text{F}$ ) is sufficient to alter the phase characteristics in the feedback loop such that the amplifier remains stable. Increasing the amplifier closed-loop gain allows the amplifier to drive increasingly larger capacitance. This increased capability is evident when observing the overshoot response of the amplifier at higher voltage gains, as shown in Figure 29. One technique for increasing the capacitive load drive capability of the amplifier operating in unity gain is to insert a small resistor ( $R_S$ ), typically  $10 \Omega$  to  $20 \Omega$ , in series with the output, as shown in Figure 28.

This resistor significantly reduces the overshoot and ringing associated with large capacitive loads. A possible problem with this technique is that a voltage divider is created with the added series resistor and any resistor connected in parallel with the capacitive load. The voltage divider introduces a gain error at the output that reduces the output swing. The error contributed by the voltage divider, however, may be insignificant. For instance, with a load resistance,  $R_L = 10 \text{ k}\Omega$  and  $R_S = 20 \Omega$ , the gain error is only about 0.2%. However, when  $R_L$  is decreased to  $600 \Omega$ , which the OPA322 is able to drive, the error increases to 7.5%.

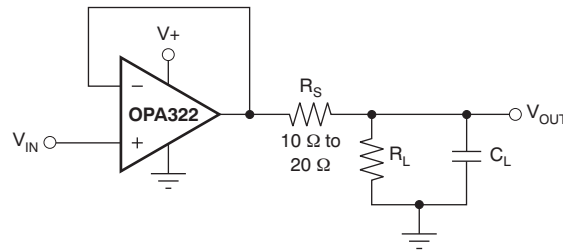

Figure 28. Improving Capacitive Load Drive

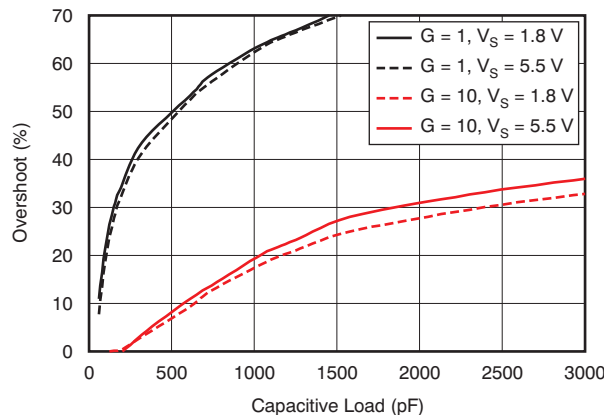

Figure 29. Small-Signal Overshoot versus Capacitive Load (100-mV<sub>PP</sub> output step)

## OVERLOAD RECOVERY TIME

Overload recovery time is the time required for the output of the amplifier to come out of saturation and recover to the linear region. Overload recovery is particularly important in applications where small signals must be amplified in the presence of large transients. Figure 30 and Figure 31 show the positive and negative overload recovery times of the OPA322, respectively. In both cases, the time elapsed before the OPA322 comes out of saturation is less than 100  $\mu$ s. In addition, the symmetry between the positive and negative recovery times allows excellent signal rectification without distortion of the output signal.

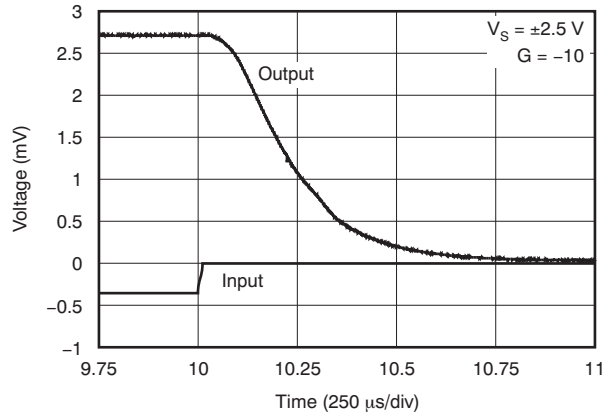

Figure 30. Positive Recovery Time

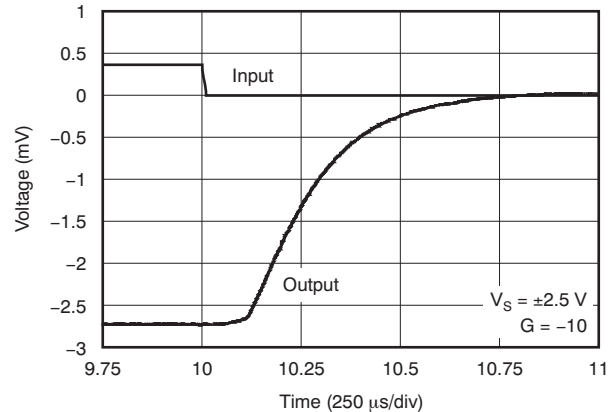

Figure 31. Negative Recovery Time

## GENERAL LAYOUT GUIDELINES

The OPA322 is a wideband amplifier. To realize the full operational performance of the device, good high-frequency printed circuit board (PCB) layout practices are required. The bypass capacitors must be connected between each supply pin and ground as close to the device as possible. The bypass capacitor traces should be designed for minimum inductance.

## LEADLESS DFN PACKAGE

The OPA2322 uses the DFN style package (also known as SON), which is a QFN with contacts on only two sides of the package bottom. This leadless package maximizes PCB space and offers enhanced thermal and electrical characteristics through an exposed pad. One of the primary advantages of the DFN package is its low height (0.8 mm).

DFN packages are physically small, and have a smaller routing area. Additionally, they offer improved thermal performance, reduced electrical parasitics, and a pinout scheme that is consistent with other commonly-used packages (such as SO and MSOP). Additionally, the absence of external leads eliminates bent-lead issues.

The DFN package can easily be mounted using standard PCB assembly techniques. See the application reports, [QFN/SON PCB Attachment \(SLUA271\)](#) and [Quad Flatpack No-Lead Logic Packages \(SCBA017\)](#), both available for download at [www.ti.com](http://www.ti.com). **The exposed leadframe die pad on the bottom of the DFN package should be connected to the most negative potential (V-).** The dimension of the exposed thermal die pad is 2mm  $\times$  1.2mm and is centered.

## APPLICATION EXAMPLES

### ACTIVE FILTER

The OPA322 is well-suited for active filter applications that require a wide bandwidth, fast slew rate, low-noise, single-supply operational amplifier. Figure 32 shows a 500-kHz, second-order, low-pass filter using the multiple-feedback (MFB) topology. The components have been selected to provide a maximally-flat Butterworth response. Beyond the cutoff frequency, roll-off is  $-40$  dB/dec. The Butterworth response is ideal for applications that require predictable gain characteristics, such as the anti-aliasing filter used in front of an ADC.

One point to observe when considering the MFB filter is that the output is inverted, relative to the input. If this inversion is not required, or not desired, a noninverting output can be achieved through one of these options:

1. adding an inverting amplifier;
2. adding an additional second-order MFB stage; or
3. using a noninverting filter topology, such as the Sallen-Key (shown in Figure 33).

MFB and Sallen-Key, low-pass and high-pass filter synthesis is quickly accomplished using TI's FilterPro™ program. This software is available as a free download at [www.ti.com](http://www.ti.com).

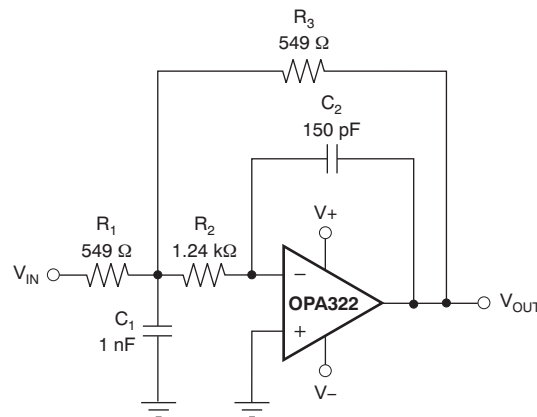

Figure 32. Second-Order Butterworth 500-kHz Low-Pass Filter

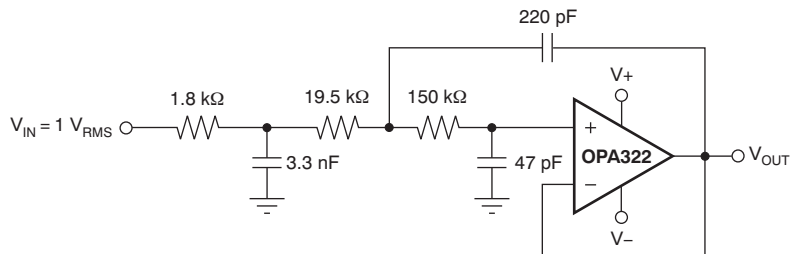

Figure 33. OPA322 Configured as a Three-Pole, 20-kHz, Sallen-Key Filter

**PACKAGING INFORMATION**

Orderable Device	Status <sup>(1)</sup>	Package Type	Package Drawing	Pins	Package Qty	Eco Plan <sup>(2)</sup>	Lead/ Ball Finish	MSL Peak Temp <sup>(3)</sup>	Samples (Requires Login)
OPA2322AID	PREVIEW	SOIC	D	8		TBD	Call TI	Call TI	
OPA2322AIDGKR	PREVIEW	MSOP	DGK	8	2500	TBD	Call TI	Call TI	
OPA2322AIDGKT	PREVIEW	MSOP	DGK	8	250	TBD	Call TI	Call TI	
OPA2322AIDR	PREVIEW	SOIC	D	8		TBD	Call TI	Call TI	
OPA2322AIDRGR	PREVIEW	SON	DRG	8	1000	TBD	Call TI	Call TI	
OPA2322AIDRGT	PREVIEW	SON	DRG	8	250	TBD	Call TI	Call TI	
OPA2322SAIDGKR	PREVIEW	MSOP	DGK	10		TBD	Call TI	Call TI	
OPA2322SAIDGKT	PREVIEW	MSOP	DGK	10		TBD	Call TI	Call TI	
OPA322AIDBVR	PREVIEW	SOT-23	DBV	5		TBD	Call TI	Call TI	
OPA322AIDBVT	PREVIEW	SOT-23	DBV	5		TBD	Call TI	Call TI	
OPA322SAIDBVR	PREVIEW	SOT-23	DBV	6		TBD	Call TI	Call TI	
OPA322SAIDBVT	PREVIEW	SOT-23	DBV	6		TBD	Call TI	Call TI	
OPA4322AIPW	PREVIEW	TSSOP	PW	14		TBD	Call TI	Call TI	
OPA4322AIPWR	PREVIEW	TSSOP	PW	14		TBD	Call TI	Call TI	
OPA4322SAIPW	PREVIEW	TSSOP	PW	16		TBD	Call TI	Call TI	
OPA4322SAIPWR	PREVIEW	TSSOP	PW	16		TBD	Call TI	Call TI	

<sup>(1)</sup> The marketing status values are defined as follows:

**ACTIVE:** Product device recommended for new designs.

**LIFEBUY:** TI has announced that the device will be discontinued, and a lifetime-buy period is in effect.

**NRND:** Not recommended for new designs. Device is in production to support existing customers, but TI does not recommend using this part in a new design.

**PREVIEW:** Device has been announced but is not in production. Samples may or may not be available.

**OBSOLETE:** TI has discontinued the production of the device.

<sup>(2)</sup> Eco Plan - The planned eco-friendly classification: Pb-Free (RoHS), Pb-Free (RoHS Exempt), or Green (RoHS & no Sb/Br) - please check <http://www.ti.com/productcontent> for the latest availability information and additional product content details.

**TBD:** The Pb-Free/Green conversion plan has not been defined.

**Pb-Free (RoHS):** TI's terms "Lead-Free" or "Pb-Free" mean semiconductor products that are compatible with the current RoHS requirements for all 6 substances, including the requirement that lead not exceed 0.1% by weight in homogeneous materials. Where designed to be soldered at high temperatures, TI Pb-Free products are suitable for use in specified lead-free processes.

**Pb-Free (RoHS Exempt):** This component has a RoHS exemption for either 1) lead-based flip-chip solder bumps used between the die and package, or 2) lead-based die adhesive used between the die and leadframe. The component is otherwise considered Pb-Free (RoHS compatible) as defined above.

**Green (RoHS & no Sb/Br):** TI defines "Green" to mean Pb-Free (RoHS compatible), and free of Bromine (Br) and Antimony (Sb) based flame retardants (Br or Sb do not exceed 0.1% by weight in homogeneous material)



<sup>(3)</sup> MSL, Peak Temp. -- The Moisture Sensitivity Level rating according to the JEDEC industry standard classifications, and peak solder temperature.

**Important Information and Disclaimer:** The information provided on this page represents TI's knowledge and belief as of the date that it is provided. TI bases its knowledge and belief on information provided by third parties, and makes no representation or warranty as to the accuracy of such information. Efforts are underway to better integrate information from third parties. TI has taken and continues to take reasonable steps to provide representative and accurate information but may not have conducted destructive testing or chemical analysis on incoming materials and chemicals. TI and TI suppliers consider certain information to be proprietary, and thus CAS numbers and other limited information may not be available for release.

In no event shall TI's liability arising out of such information exceed the total purchase price of the TI part(s) at issue in this document sold by TI to Customer on an annual basis.

**TAPE AND REEL INFORMATION**

**QUADRANT ASSIGNMENTS FOR PIN 1 ORIENTATION IN TAPE**

\*All dimensions are nominal

Device	Package Type	Package Drawing	Pins	SPQ	Reel Diameter (mm)	Reel Width W1 (mm)	A0 (mm)	B0 (mm)	K0 (mm)	P1 (mm)	W (mm)	Pin1 Quadrant
OPA2322AIDGKR	MSOP	DGK	8	2500	330.0	12.4	5.3	3.4	1.4	8.0	12.0	Q1
OPA2322AIDGKT	MSOP	DGK	8	250	180.0	12.4	5.3	3.4	1.4	8.0	12.0	Q1
OPA2322AIDRGR	SON	DRG	8	1000	330.0	12.4	3.3	3.3	1.1	8.0	12.0	Q2

**TAPE AND REEL BOX DIMENSIONS**

\*All dimensions are nominal

Device	Package Type	Package Drawing	Pins	SPQ	Length (mm)	Width (mm)	Height (mm)
OPA2322AIDGKR	MSOP	DGK	8	2500	346.0	346.0	29.0
OPA2322AIDGKT	MSOP	DGK	8	250	190.5	212.7	31.8
OPA2322AIDRGR	SON	DRG	8	1000	346.0	346.0	29.0

DBV (R-PDSO-G5)

PLASTIC SMALL-OUTLINE PACKAGE

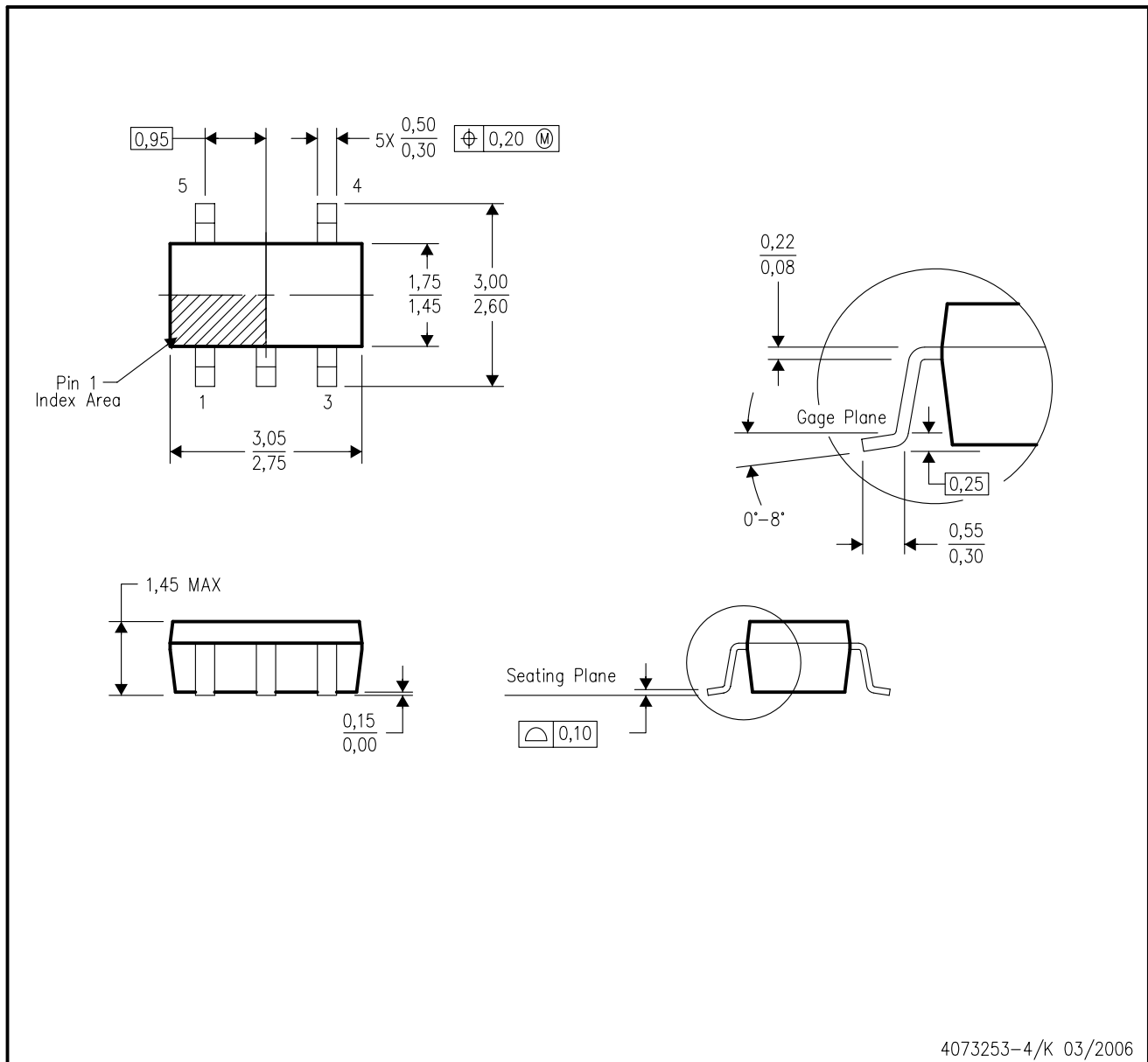

- NOTES:
- A. All linear dimensions are in millimeters.
  - B. This drawing is subject to change without notice.
  - C. Body dimensions do not include mold flash or protrusion. Mold flash and protrusion shall not exceed 0.15 per side.
  - D. Falls within JEDEC MO-178 Variation AA.

DBV (R-PDSO-G6)

PLASTIC SMALL-OUTLINE PACKAGE

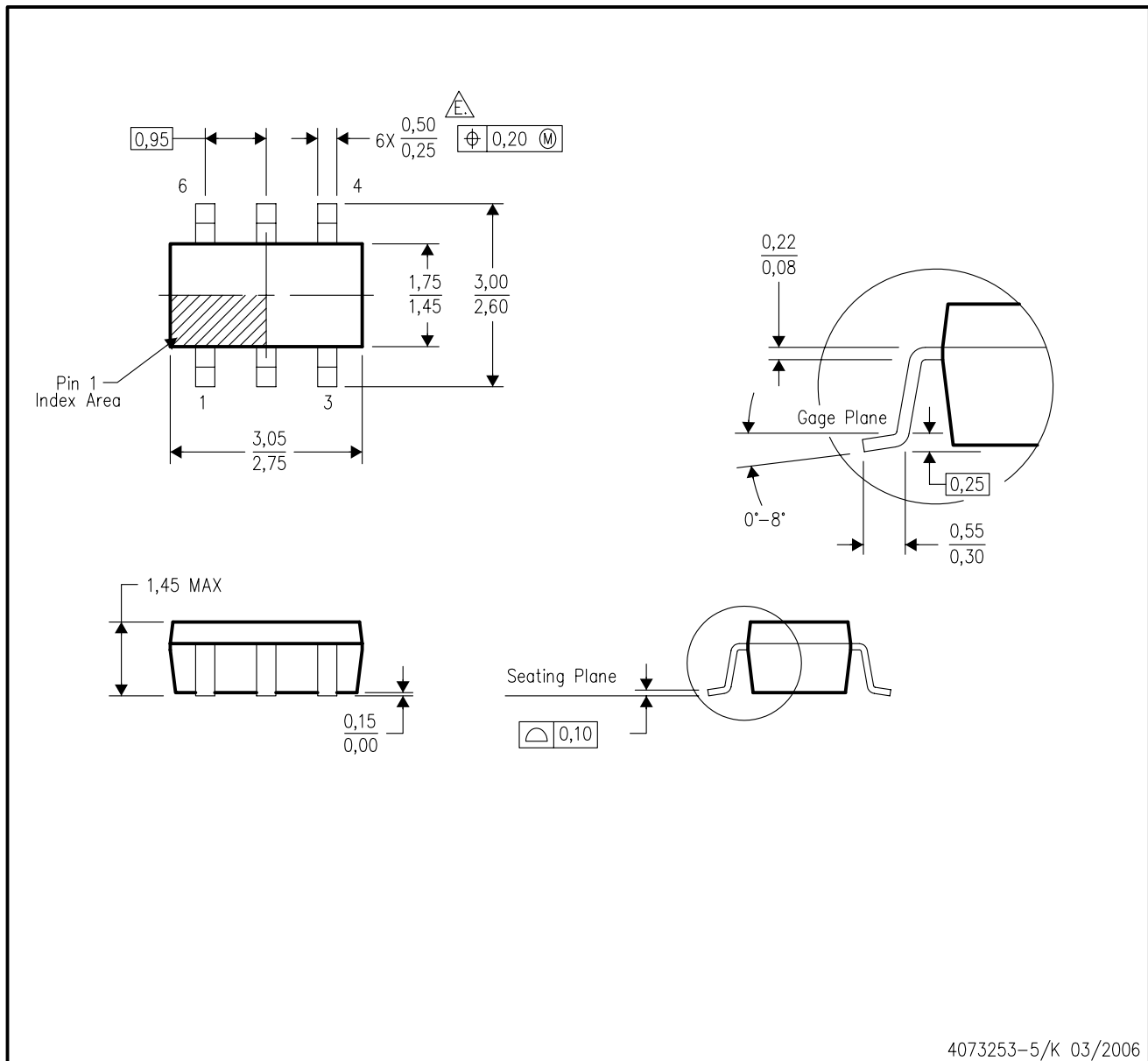

- NOTES:
- All linear dimensions are in millimeters.
  - This drawing is subject to change without notice.
  - Body dimensions do not include mold flash or protrusion. Mold flash and protrusion shall not exceed 0.15 per side.
  - Leads 1,2,3 may be wider than leads 4,5,6 for package orientation.
- $\Delta E$  Falls within JEDEC MO-178 Variation AB, except minimum lead width.

DGK (S-PDSO-G8)

PLASTIC SMALL-OUTLINE PACKAGE

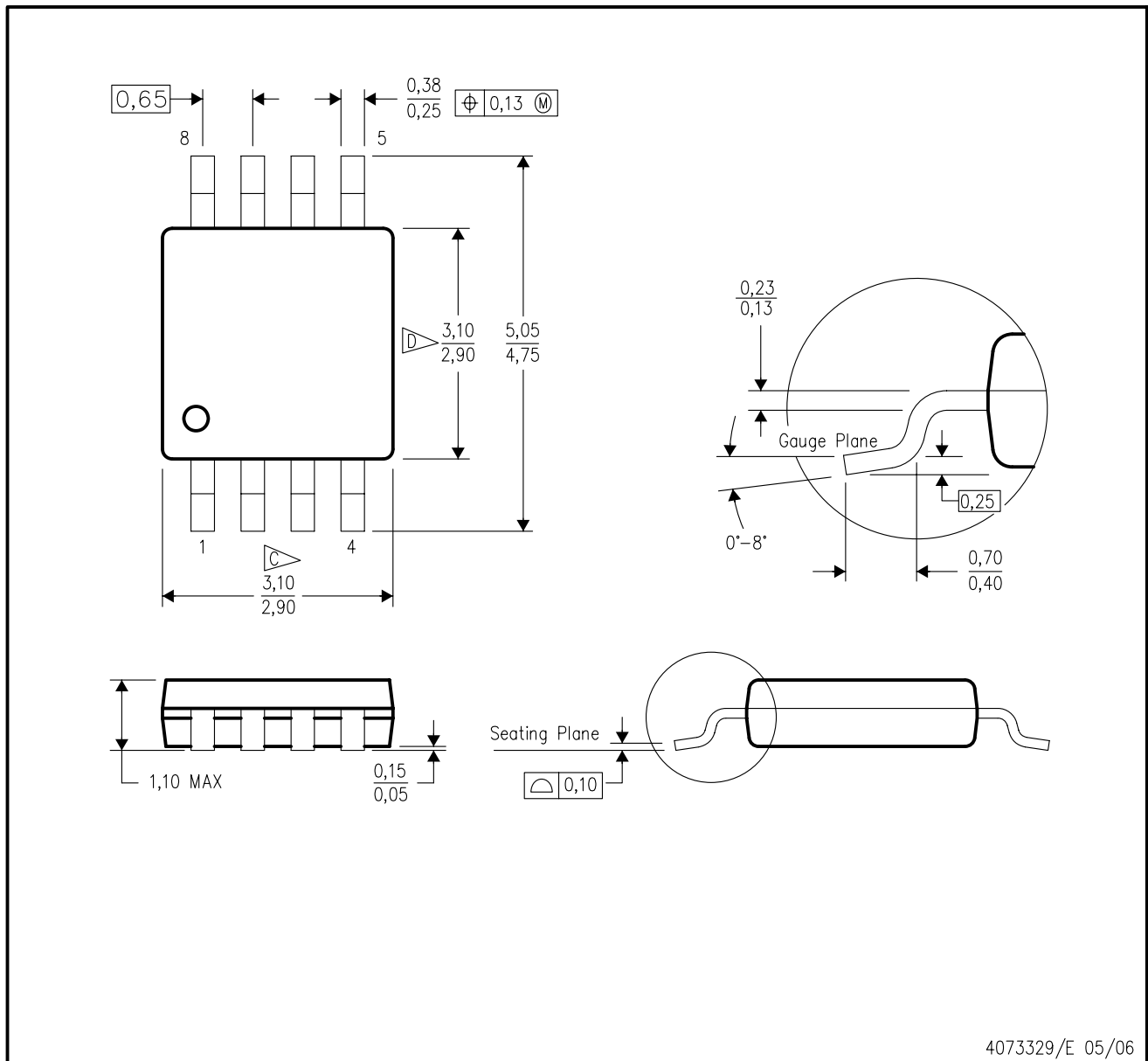

4073329/E 05/06

- NOTES:
- A. All linear dimensions are in millimeters.
  - B. This drawing is subject to change without notice.
  - C. Body length does not include mold flash, protrusions, or gate burrs. Mold flash, protrusions, or gate burrs shall not exceed 0.15 per end.
  - D. Body width does not include interlead flash. Interlead flash shall not exceed 0.50 per side.
  - E. Falls within JEDEC MO-187 variation AA, except interlead flash.

DRG (S-PWSON-N8)

PLASTIC SMALL OUTLINE NO-LEAD

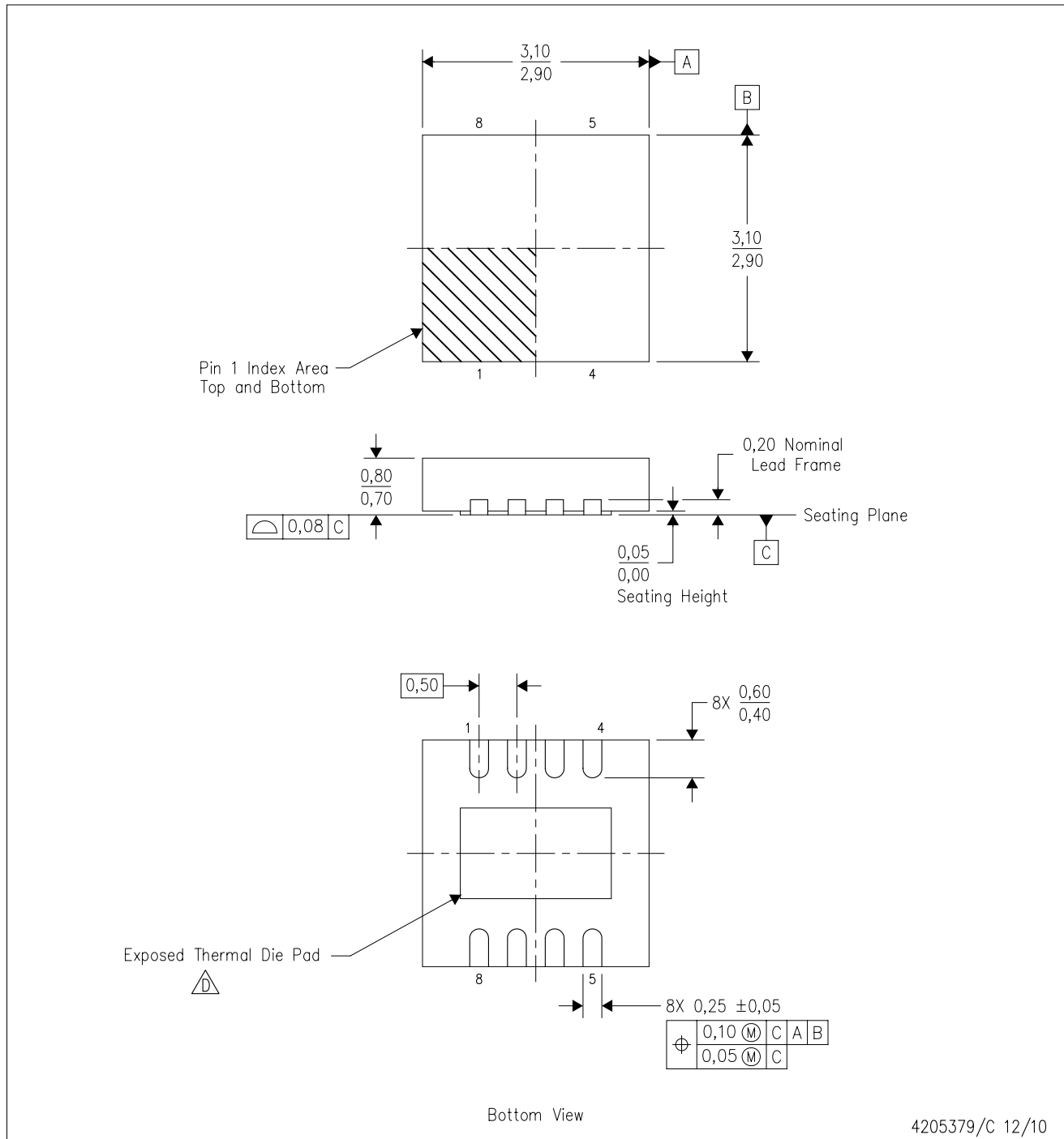

- NOTES:
- A. All linear dimensions are in millimeters. Dimensioning and tolerancing per ASME Y14.5M-1994.
  - B. This drawing is subject to change without notice.
  - C. SON (Small Outline No-Lead) package configuration.
  - D. The package thermal pad must be soldered to the board for thermal and mechanical performance. See the Product Data Sheet for details regarding the exposed thermal pad dimensions.
  - E. JEDEC MO-229 package registration pending.

PW (R-PDSO-G14)

PLASTIC SMALL OUTLINE

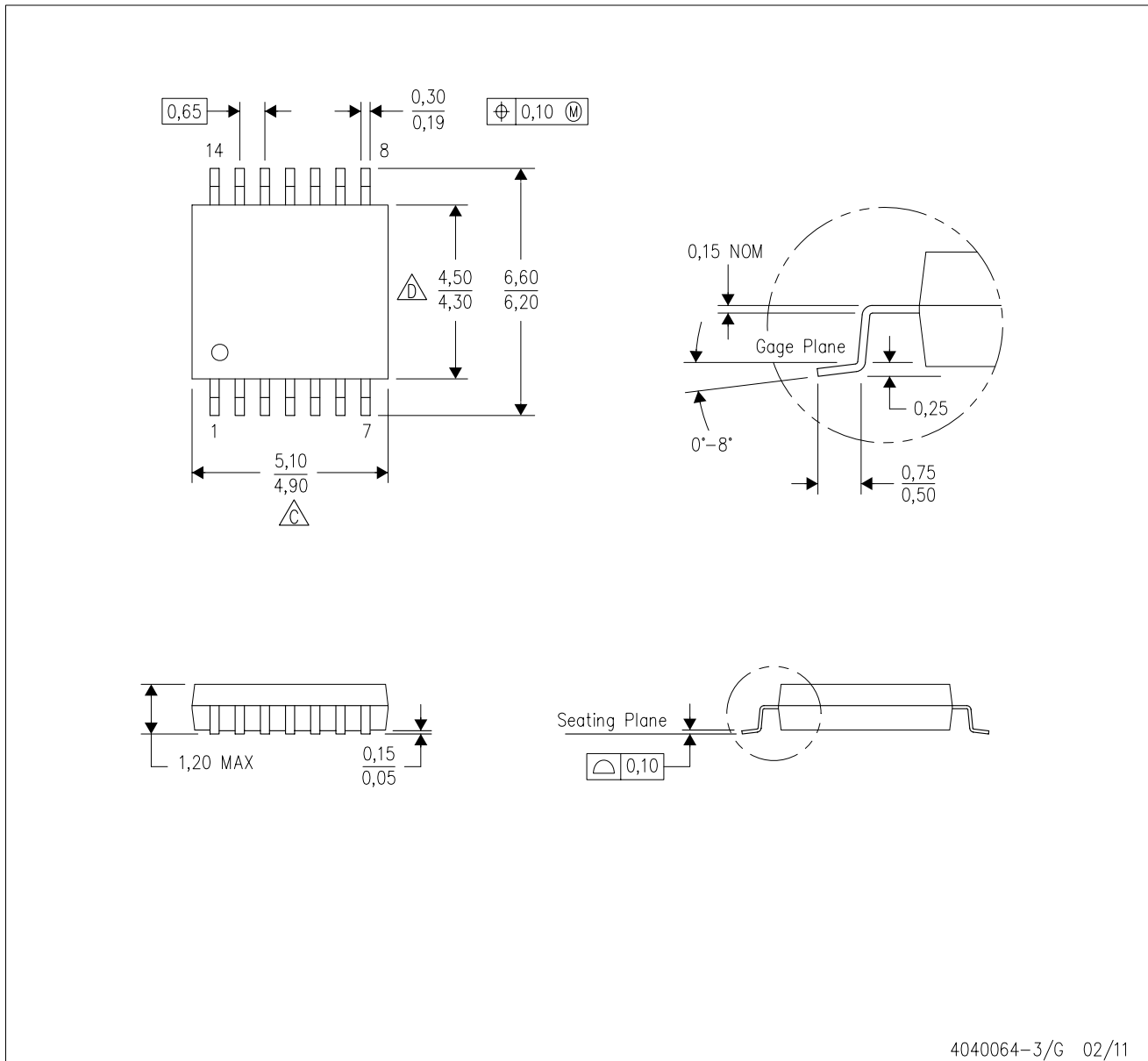

4040064-3/G 02/11

- NOTES:
- A. All linear dimensions are in millimeters. Dimensioning and tolerancing per ASME Y14.5M-1994.
  - B. This drawing is subject to change without notice.
  - C. Body length does not include mold flash, protrusions, or gate burrs. Mold flash, protrusions, or gate burrs shall not exceed 0,15 each side.
  - D. Body width does not include interlead flash. Interlead flash shall not exceed 0,25 each side.
  - E. Falls within JEDEC MO-153



PW (R-PDSO-G16)

PLASTIC SMALL OUTLINE

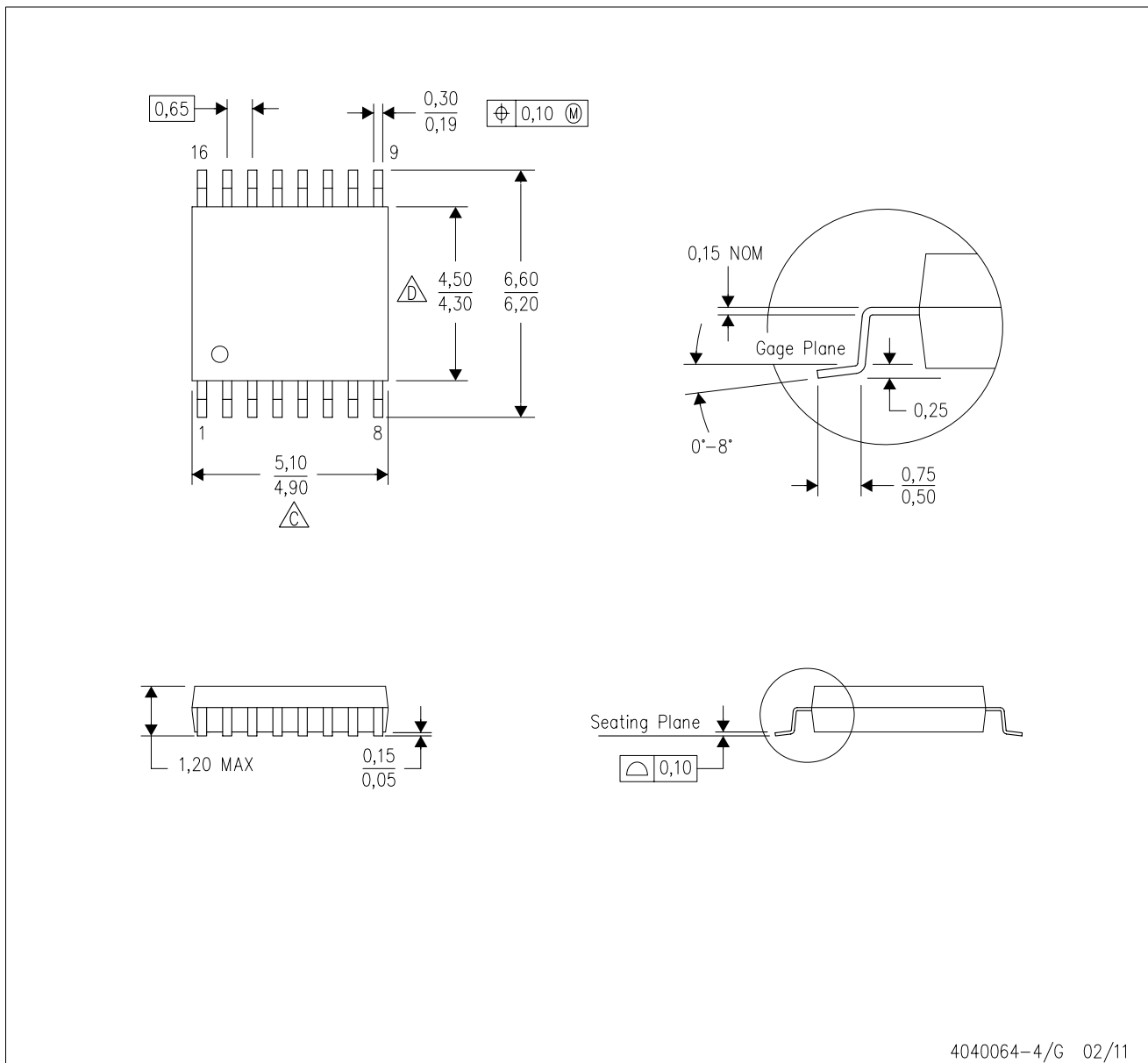

4040064-4/G 02/11

- NOTES:
- A. All linear dimensions are in millimeters. Dimensioning and tolerancing per ASME Y14.5M-1994.
  - B. This drawing is subject to change without notice.
  - C. Body length does not include mold flash, protrusions, or gate burrs. Mold flash, protrusions, or gate burrs shall not exceed 0,15 each side.
  - D. Body width does not include interlead flash. Interlead flash shall not exceed 0,25 each side.
  - E. Falls within JEDEC MO-153

D (R-PDSO-G8)

PLASTIC SMALL OUTLINE

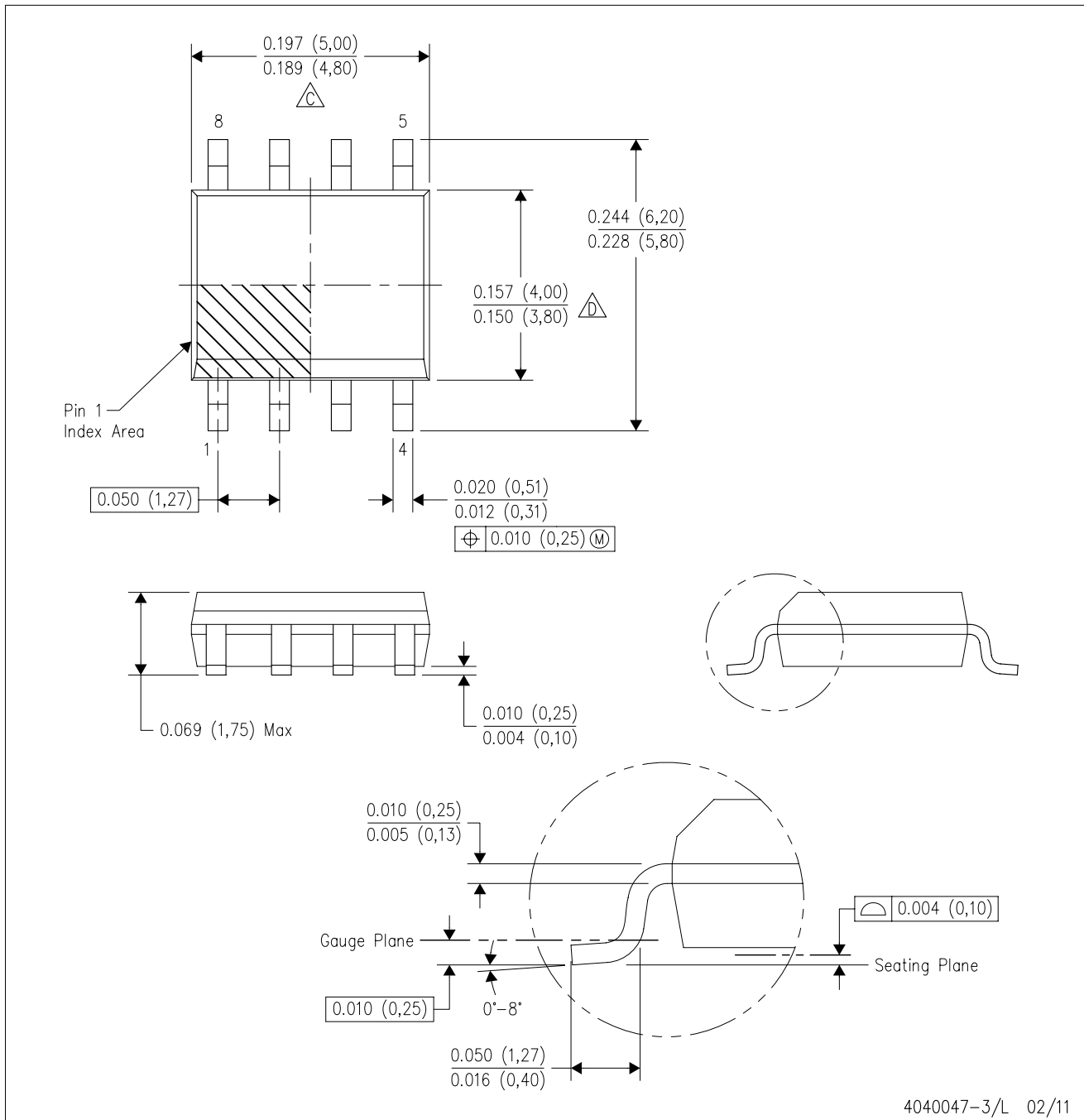

- NOTES:
- A. All linear dimensions are in inches (millimeters).
  - B. This drawing is subject to change without notice.
  - C. Body length does not include mold flash, protrusions, or gate burrs. Mold flash, protrusions, or gate burrs shall not exceed 0.006 (0,15) each side.
  - D. Body width does not include interlead flash. Interlead flash shall not exceed 0.017 (0,43) each side.
  - E. Reference JEDEC MS-012 variation AA.

## 重要声明

德州仪器(TI) 及其下属子公司有权在不事先通知的情况下, 随时对所提供的产品和服务进行更正、修改、增强、改进或其它更改, 并有权随时中止提供任何产品和服务。客户在下订单前应获取最新的相关信息, 并验证这些信息是否完整且是最新的。所有产品的销售都遵循在订单确认时所提供的TI 销售条款与条件。

TI 保证其所销售的硬件产品的性能符合TI 标准保修的适用规范。仅在TI 保证的范围内, 且TI 认为有必要时才会使用测试或其它质量控制技术。除非政府做出了硬性规定, 否则没有必要对每种产品的所有参数进行测试。

TI 对应用帮助或客户产品设计不承担任何义务。客户应对其使用TI 组件的产品和应用自行负责。为尽量减小与客户产品和应用相关的风险, 客户应提供充分的设计与操作安全措施。

TI 不对任何TI 专利权、版权、屏蔽作品权或其它与使用了TI 产品或服务的组合设备、机器、流程相关的TI 知识产权中授予的直接或隐含权限作出任何保证或解释。TI 所发布的与第三方产品或服务有关的信息, 不能构成从TI 获得使用这些产品或服务的许可、授权、或认可。使用此类信息可能需要获得第三方的专利权或其它知识产权方面的许可, 或是TI 的专利权或其它知识产权方面的许可。

对于TI 的产品手册或数据表, 仅在没有对内容进行任何篡改且带有相关授权、条件、限制和声明的情况下才允许进行复制。在复制信息的过程中对内容的篡改属于非法的、欺诈性商业行为。TI 对此类篡改过的文件不承担任何责任。

在转售TI 产品或服务时, 如果存在对产品或服务参数的虚假陈述, 则会失去相关TI 产品或服务的明示或暗示授权, 且这是非法的、欺诈性商业行为。TI 对此类虚假陈述不承担任何责任。

TI 产品未获得用于关键的安全应用中的授权, 例如生命支持应用(在该类应用中一旦TI 产品故障将预计造成重大的人员伤亡), 除非各方官员已经达成了专门管控此类使用的协议。购买者的购买行为即表示, 他们具备有关其应用安全以及规章衍生所需的所有专业技术和知识, 并且认可和同意, 尽管任何应用相关信息或支持仍可能由TI 提供, 但他们将独力负责满足在关键安全应用中使用其产品及TI 产品所需的所有法律、法规和安全相关要求。此外, 购买者必须全额赔偿因在此类关键安全应用中使用TI 产品而对TI 及其代表造成的损失。

TI 产品并非设计或专门用于军事/航空应用, 以及环境方面的产品, 除非TI 特别注明该产品属于“军用”或“增强型塑料”产品。只有TI 指定的军用产品才满足军用规格。购买者认可并同意, 对TI 未指定军用的产品进行军事方面的应用, 风险由购买者单独承担, 并且独力负责在此类相关使用中满足所有法律和法规要求。

TI 产品并非设计或专门用于汽车应用以及环境方面的产品, 除非TI 特别注明该产品符合ISO/TS 16949 要求。购买者认可并同意, 如果他们在汽车应用中使用任何未被指定的产品, TI 对未能满足应用所需要求不承担任何责任。

可访问以下URL 地址以获取有关其它TI 产品和应用解决方案的信息:

	产品		应用
数字音频	<a href="http://www.ti.com.cn/audio">www.ti.com.cn/audio</a>	通信与电信	<a href="http://www.ti.com.cn/telecom">www.ti.com.cn/telecom</a>
放大器和线性器件	<a href="http://www.ti.com.cn/amplifiers">http://www.ti.com.cn/amplifiers</a>	计算机及周边	<a href="http://www.ti.com.cn/computer">www.ti.com.cn/computer</a>
数据转换器	<a href="http://www.ti.com.cn/dataconverters">http://www.ti.com.cn/dataconverters</a>	消费电子	<a href="http://www.ti.com/consumer-apps">www.ti.com/consumer-apps</a>
DLP® 产品	<a href="http://www.dlp.com">www.dlp.com</a>	能源	<a href="http://www.ti.com/energy">www.ti.com/energy</a>
DSP - 数字信号处理器	<a href="http://www.ti.com.cn/dsp">http://www.ti.com.cn/dsp</a>	工业应用	<a href="http://www.ti.com.cn/industrial">www.ti.com.cn/industrial</a>
时钟和计时器	<a href="http://www.ti.com.cn/clockandtimers">http://www.ti.com.cn/clockandtimers</a>	医疗电子	<a href="http://www.ti.com.cn/medical">www.ti.com.cn/medical</a>
接口	<a href="http://www.ti.com.cn/interface">http://www.ti.com.cn/interface</a>	安防应用	<a href="http://www.ti.com.cn/security">www.ti.com.cn/security</a>
逻辑	<a href="http://www.ti.com.cn/logic">http://www.ti.com.cn/logic</a>	汽车电子	<a href="http://www.ti.com.cn/automotive">www.ti.com.cn/automotive</a>
电源管理	<a href="http://www.ti.com.cn/power">http://www.ti.com.cn/power</a>	视频和影像	<a href="http://www.ti.com.cn/video">www.ti.com.cn/video</a>
微控制器 (MCU)	<a href="http://www.ti.com.cn/microcontrollers">http://www.ti.com.cn/microcontrollers</a>	无线通信	<a href="http://www.ti.com.cn/wireless">www.ti.com.cn/wireless</a>
RFID 系统	<a href="http://www.ti.com.cn/rfidsys">http://www.ti.com.cn/rfidsys</a>		
RF/IF 和 ZigBee® 解决方案	<a href="http://www.ti.com.cn/radiofre">www.ti.com.cn/radiofre</a>		
	TI E2E 工程师社区		<a href="http://e2e.ti.com/cn/">http://e2e.ti.com/cn/</a>

邮寄地址: 上海市浦东新区世纪大道 1568 号, 中建大厦 32 楼 邮政编码: 200122  
Copyright © 2011 德州仪器 半导体技术(上海)有限公司

[www.BDTIC.com/TI](http://www.BDTIC.com/TI)