

Features

- Dual Outputs:
 - +3.3V/2.5V
 - +3.3V/1.5V
 - +3.3V/1.8V
- Adjustable Output Voltages
- Remote Sense (both outputs)
- Standby Function
- Over-Temperature Protection
- Soft-Start
- Internal Sequencing
- 23-pin Excalibur™ Package

Description

The PT6930 Excalibur™ series of 8-A dual-output ISRs are designed to power DSP ICs. Both output voltages are independently adjustable with external resistors. The second output may also be set to an alternate lower bus voltage with a simple pin strap. Internal power sequencing of both outputs, during both power-up and power-down, meets the requirements of most DSP chipsets.

Standard Application

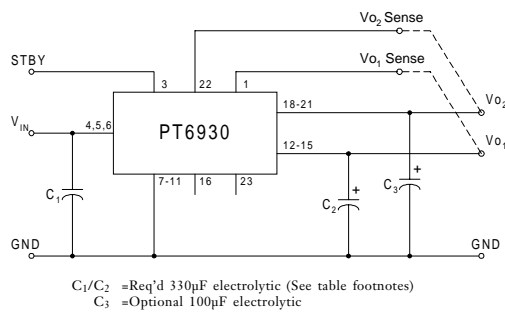

Pin-Out Information

Pin	Function	Pin	Function
1	VO ₁ Sense	13	VO ₁
2	No Connect	14	VO ₁
3	STBY	15	VO ₁
4	V _{IN}	16	VO ₁ Adjust
5	V _{IN}	17	No Connect
6	V _{IN}	18	VO ₂
7	GND	19	VO ₂
8	GND	20	VO ₂
9	GND	21	VO ₂
10	GND	22	VO ₂ Sense
11	GND	23	VO ₂ Adjust*
12	VO ₁		

* Note: VO₁ & VO₂ Adjust can be pin-strapped to an alternative lower bus voltage. Consult the voltage adjustment application note for more information.

Ordering Information

- PT6931□ = +3.3 Volts
 +2.5/1.8 Volts
 PT6932□ = +3.3 Volts
 +1.5/1.2 Volts
 PT6933□ = +3.3 Volts
 +1.8/1.2 Volts

PT Series Suffix (PT1234X)

Case/Pin Configuration	
Vertical Through-Hole	N
Horizontal Through-Hole	A
Horizontal Surface Mount	C

(For dimensions and PC board layout, see Package Styles 1320 and 1330).

Specifications

Characteristics (T _a = 25°C unless noted)	Symbols	Conditions	PT6930 SERIES			Units	
			Min	Typ	Max		
Output Current	I _{o1} , I _{o2}	T _a = +60°C, 200 LFM, pkg N	VO ₁ = 3.3V	0.1 (1)	—	5.5 (2)	A
			VO ₂ = 2.5V	0	—	2.2 (2)	
			VO ₂ = 1.8V	0	—	1.75 (2)	
			VO ₂ = 1.5V	0	—	1.45 (2)	
			VO ₁ = 1.2V	0	—	1.2 (2)	
		T _a = +25°C, natural convection	VO ₁ = 3.3V	0.1 (1)	—	6.0 (2)	A
			VO ₂ = 2.5V	0	—	2.2 (2)	
			VO ₂ = 1.8V	0	—	1.75 (2)	
			VO ₂ = 1.5V	0	—	1.45 (2)	
			VO ₁ = 1.2V	0	—	1.2 (2)	
Input Voltage Range	V _{in}	0.1A ≤ I _o ≤ I _{typ}	4.5	—	5.5	V	
Output Voltage Tolerance	ΔV _o	V _{in} = +5V, I _o = I _{typ} , both outputs 0°C ≤ T _a ≤ +65°C	V _o -0.1	—	V _o +0.1	V	
Line Regulation	Reg _{line}	4.5V ≤ V _{in} ≤ 5.5V, I _o = I _{typ}	VO ₁ VO ₂	— ±7 ±7	±17 ±13	V	
Load Regulation	Reg _{load}	V _{in} = +5V, 0.1 ≤ I _o ≤ I _{typ}	VO ₁ VO ₂	— —	±17 ±4	mV	
V _o Ripple/Noise	V _n	V _{in} = +5V, I _o = I _{typ}	VO ₁ VO ₂	— —	50 25	mV	
Transient Response with C ₂ = 330µF	t _{tr} V _{os}	I _o step between 0.5xI _{typ} and I _{typ} V _o over/undershoot	VO ₁	—	25	—	µSec
			VO ₂	—	60	—	mV
Efficiency	η	V _{in} = +5V, I _o = 4A total	—	75	—	%	
Switching Frequency	f _o	4.5V ≤ V _{in} ≤ 5.5V 0.1A ≤ I _o ≤ I _{typ}	475	600	725	kHz	

(Continued)

PT6930 Series

8-A 5V-Input Dual-Output Integrated Switching Regulator

Specifications *(From previous page)*

Characteristics ($T_a = 25^\circ\text{C}$ unless noted)	Symbols	Conditions	PT6930 SERIES			Units
			Min	Typ	Max	
Absolute Maximum Operating Temperature Range	T_a	—	-40 (3)	—	+85 (4)	$^\circ\text{C}$
Storage Temperature	T_s	—	-40	—	+125	$^\circ\text{C}$
Weight	—	Vertical/Horizontal	—	29	—	grams

- Notes:**
- (1) I_{Lmin} current of 0.1A can be divided between both outputs; V_{O1} , or V_{O2} . The ISR will operate down to no-load with reduced specifications.
 - (2) I_{Lmax} listed for each output assumes the maximum current drawn simultaneously on both outputs. Consult the factory for the absolute maximum.
 - (3) For operating temperatures below 0°C , use tantalum type capacitors at both the input and output.
 - (4) See Safe Operating Area curves for appropriate derating.

Input/Output Capacitors: The PT6930 series requires a minimum capacitance of $330\mu\text{F}$ at both the input and V_{O1} output for proper operation in all applications. In addition, the input capacitor, C_1 , must be rated for a minimum of 1.0Arms ripple current. For transient or dynamic dynamic loads, additional capacitance may be required.

TYPICAL CHARACTERISTICS

PT6930 Series Performance *(See Note A)*

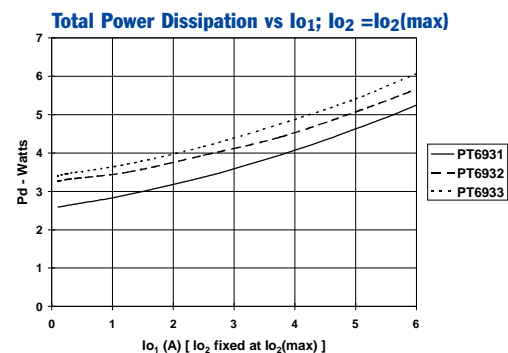
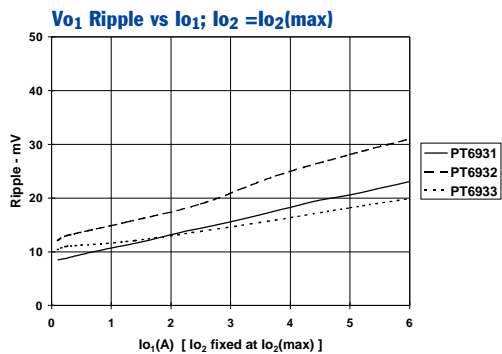
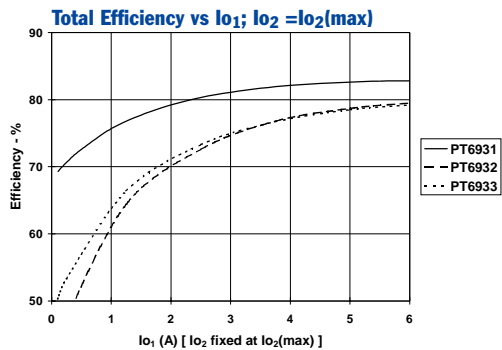

Safe Operating Area @ $V_{IN} = 5\text{V}$ *(See Note B)*

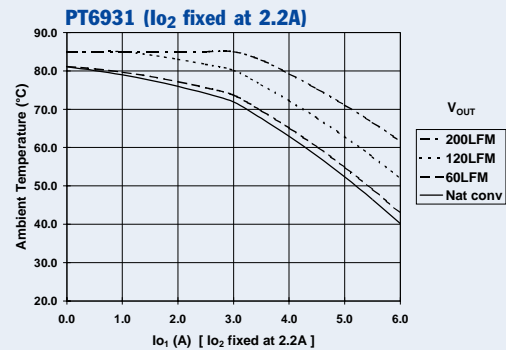

Note A: All characteristic data in the above graphs has been developed from actual products tested at 25°C . This data is considered typical data for the ISR.

Note B: SOA curves represent operating conditions at which internal components are at or below the manufacturer's maximum rated operating temperatures.

Adjusting the Output Voltage of the PT6920 and PT6930 Dual Output Voltage ISRs

Each output voltage from the PT6920 and PT6930 series of ISRs can be independently adjusted higher or lower than the factory trimmed pre-set voltage. V_{O1} or V_{O2} may each be adjusted either up or down using a single external resistor ². Table 1 gives the adjustment range for both V_{O1} and V_{O2} for each model in the series as $V_a(\text{min})$ and $V_a(\text{max})$. Note that V_{O2} must always be lower than V_{O1} ³.

V_{O1} Adjust Up: To increase the output, add a resistor R4 between pin 16 (V_1 Adjust) and pins 7-11 (GND) ².

V_{O1} Adjust Down: Add a resistor (R3), between pin 16 (V_1 Adjust) and pin 1 (V_{O1} Sense) ².

V_{O2} Adjust Up: Add a resistor R2 between pin 23 (V_2 Adjust) and pins 7-11 (GND) ².

V_{O2} Adjust Down: Add a resistor (R1) between pin 23 (V_2 Adjust) and pin 22 (V_{O2} Sense) ².

Refer to Figure 1 and Table 2 for both the placement and value of the required resistor.

Notes:

1. The output voltages, V_{O1} and V_{O2} , may be adjusted independently.
2. Use only a single 1% resistor in either the (R3) or R4 location to adjust V_{O1} , and in the (R1) or R2 location to adjust V_{O2} . Place the resistor as close to the ISR as possible.
3. V_{O2} must always be at least 0.2V lower than V_{O1} .
4. V_{O2} on both the PT6921 and PT6931 models may be adjusted from 2.5V to 1.8V by simply connecting pin 22 (V_{O2} Sense) to pin 23 (V_{O2} Adjust). For more details, consult the data sheet.

5. If V_{O1} is increased above 3.3V, the minimum input voltage to the ISR must also be increased. The minimum required input voltage must be $(V_{O1} + 1.2)V$ or 4.5V, whichever is greater. Do not exceed 5.5V
6. Never connect capacitors to either the V_{O1} Adjust or V_{O2} Adjust pins. Any capacitance added to these control pins will affect the stability of the respective regulated output.
7. Adjusting either voltage (V_{O1} or V_{O2}) may increase the power dissipation in the regulator, and correspondingly change the maximum current available at either output. Consult the factory for application assistance.

The adjust up and adjust down resistor values can also be calculated using the following formulas. Be sure to select the correct formula parameter from Table 1 for the output and model being adjusted.

$$(R1) \text{ or } (R3) = \frac{R_o(V_a - V_r)}{V_o - V_a} - R_s \quad \text{k}\Omega$$

$$R2 \text{ or } R4 = \frac{V_r \cdot R_o}{V_a - V_o} - R_s \quad \text{k}\Omega$$

Where: V_o = Original output voltage, (V_{O1} or V_{O2})
 V_a = Adjusted output voltage
 V_r = The reference voltage from Table 1
 R_o = The resistance value from Table 1
 R_s = The series resistance from Table 1

Table 1

PT6920 ADJUSTMENT RANGE AND FORMULA PARAMETERS				
Output Bus	V_{O1}	V_{O2}		
Series Pt #				
Standard Case	PT6921/22	PT6921	PT6922	
Excalibur Case	PT6931/32	PT6931	PT6932	PT6933
Adj. Resistor	(R3)/R4	(R1)/R2	(R1)/R2	(R1)/R2
$V_o(\text{nom})$	3.3V	2.5V	1.5V	1.8V
$V_a(\text{min})$	2.3V	1.8V	1.2V	1.2V
$V_a(\text{max})$	3.6V	3.0V	3.0V	3.0V
V_r	1.02V	1.0V	1.0V	1.0V
R_o (k Ω)	12.1	10.0	9.76	10.0
R_s (k Ω)	12.1	11.5	6.49	3.32

Figure 1

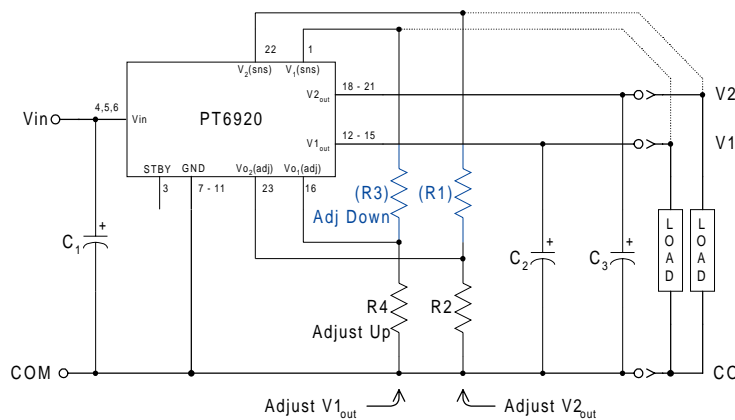

PT6920/PT6930 Series

Table 2

PT6920/PT6930 ADJUSTMENT RESISTOR VALUES

Output Bus	Vo ₁	Vo ₂		
Series Pt#				
Standard Case	PT6921/6922	PT6921	PT6922	
Excalibur Case	PT6931/6932	PT6931	PT6932	PT6933
Adj Resistor	(R3)/R4	(R1)/R2	(R1)/R2	(R1)/R2
V _o (nom)	3.3Vdc	2.5Vdc	1.5Vdc	1.8Vdc
V _a (req'd)				
1.2		(0.0)kΩ	(0.0)kΩ	
1.25		(3.3)kΩ	(1.2)kΩ	
1.3		(8.2)kΩ	(2.7)kΩ	
1.35		(16.3)kΩ	(4.5)kΩ	
1.4		(32.6)kΩ	(6.7)kΩ	
1.45		(81.4)kΩ	(9.5)kΩ	
1.5			(13.3)kΩ	
1.55		189.0kΩ	(18.7)kΩ	
1.6		91.1kΩ	(26.7)kΩ	
1.65		58.6kΩ	(40.0)kΩ	
1.7		42.3kΩ	(66.7)kΩ	
1.75		32.6kΩ	(147.0)kΩ	
1.8		(0.0)kΩ	26.0kΩ	
1.85		(1.6)kΩ	21.4kΩ	197.0kΩ
1.9		(3.5)kΩ	17.9kΩ	96.7kΩ
1.95		(5.8)kΩ	15.2kΩ	63.3kΩ
2.0		(8.5)kΩ	13.0kΩ	46.7kΩ
2.05		(11.8)kΩ	11.3kΩ	36.7kΩ
2.1		(16.0)kΩ	9.8kΩ	30.0kΩ
2.15		(21.4)kΩ	8.5kΩ	25.3kΩ
2.2		(28.5)kΩ	7.5kΩ	21.7kΩ
2.25		(38.5)kΩ	6.5kΩ	18.9kΩ
2.3	(3.4)kΩ	(53.5)kΩ	5.7kΩ	16.7kΩ
2.35	(4.8)kΩ	(78.5)kΩ	5.0kΩ	14.9kΩ
2.4	(6.5)kΩ	(129.0)kΩ	4.4kΩ	13.3kΩ
2.45	(8.3)kΩ	(279.0)kΩ	3.8kΩ	12.1kΩ
2.5	(10.3)kΩ		3.3kΩ	11.0kΩ
2.55	(12.6)kΩ	189.0kΩ	2.8kΩ	10.0kΩ
2.6	(15.2)kΩ	88.5kΩ	2.4kΩ	9.2kΩ
2.65	(18.2)kΩ	55.2kΩ	2.0kΩ	8.4kΩ
2.7	(21.8)kΩ See Note 3	38.5kΩ	1.6kΩ	7.8kΩ
2.75	(26.0)kΩ	28.5kΩ	1.3kΩ	7.2kΩ
2.8	(31.0)kΩ	21.8kΩ	1.0kΩ	6.7kΩ
2.85	(37.1)kΩ	17.1kΩ	0.7kΩ	6.2kΩ
2.9	(44.8)kΩ	13.5kΩ	0.5kΩ	5.8kΩ
2.95	(54.6)kΩ	10.7kΩ	0.2kΩ	5.4kΩ
3.0	(67.8)kΩ	8.5kΩ	0.0kΩ	5.0kΩ
3.05	(86.2)kΩ			
3.1	(114.0)kΩ			
3.15	(160.0)kΩ			
3.2	(252.0)kΩ			
3.25	(528.0)kΩ			
3.3				
3.4	111.0kΩ See Note 5			
3.5	49.6kΩ			
3.6	29.0kΩ			

R1/R3 = (Blue) R2/R4 = Black



Using the Standby Function on the PT6920 and PT6930 Dual Output Voltage Converters

Both output voltages of the 23-pin PT6920/6930 dual output converter may be disabled using the regulator's standby function. This function may be used in applications that require power-up/shutdown sequencing, or wherever there is a requirement to control the output voltage On/Off status with external circuitry.

The standby function is provided by the *STBY** control (pin 3). If pin 3 is left open-circuit the regulator operates normally, and provides a regulated output at both V_{O1} (pins 12–15) and V_{O2} (pins 18–21) whenever a valid supply voltage is applied to V_{in} (pins 4, 5, & 6) with respect to GND (pins 7–11). If a low voltage is then applied to pin 3, both regulator outputs will be simultaneously disabled and the input current drawn by the ISR will typically drop to less than 30mA (50mA max). The standby control may also be used to hold-off both regulator outputs during the period that input power is applied.

The standby pin is ideally controlled using an open-collector (or open-drain) discrete transistor (See Figure 1). It may also be driven directly from a dedicated TTL³ compatible gate. Table 1 provides details of the threshold requirements.

Table 1 Inhibit Control Thresholds^{2,3}

Parameter	Min	Max
Enable (V_{IH})	1.8V	V_{in}
Disable (V_{IL})	-0.1V	0.8V

Notes:

1. The Standby/Inhibit control logic is similar for all Power Trends' modules, but the flexibility and threshold tolerances will be different. For specific information on this function for other regulator models, consult the applicable application note.
2. The Standby control pin is ideally controlled using an open-collector (or open-drain) discrete transistor and requires no external pull-up resistor. To disable the regulator output, the control pin must be pulled to less than 0.8Vdc with a low-level 0.5mA sink to ground.
3. The Standby input on the PT6920/6930 series may be driven by a differential output device, making it directly compatible with TTL logic. The control input has an internal pull-up to the input voltage V_{in} . A voltage of 1.8V or greater ensures that the regulator is enabled. *Do not* use devices that can drive the Standby control input above 5.5V or V_{in} .

Figure 1

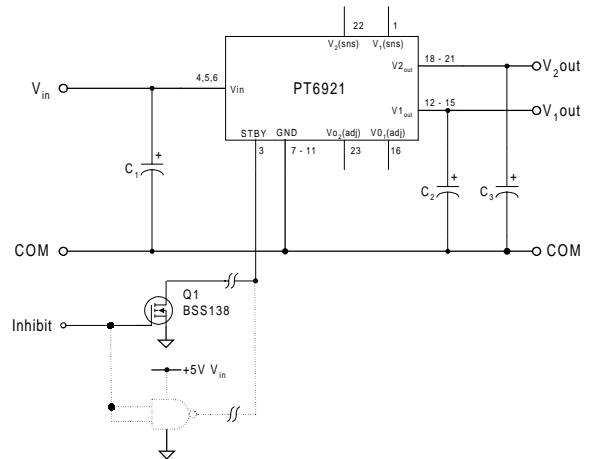

Turn-On Time: Turning Q_1 in Figure 1 off removes the low-voltage signal at pin 3 and enables both outputs from the PT6920/6930 regulator. Following a delay of about 10–20ms, V_{O1} and V_{O2} rise together until the lower voltage, V_{O2} , reaches its set output. V_{O1} then continues to rise until both outputs reach full regulation voltage. The total power-up time is less than 25ms, and is relatively independent of load, temperature, and output capacitance. Figure 2 shows waveforms of the output voltages V_{O1} and V_{O2} , for a PT6931 (3.3V/2.5V). The turn-off of Q_1 corresponds to the rise in V_{stby} . The waveforms were measured with a 5Vdc input voltage, and with resistive loads of 5A and 2A at the V_{O1} and V_{O2} outputs respectively.

Figure 2

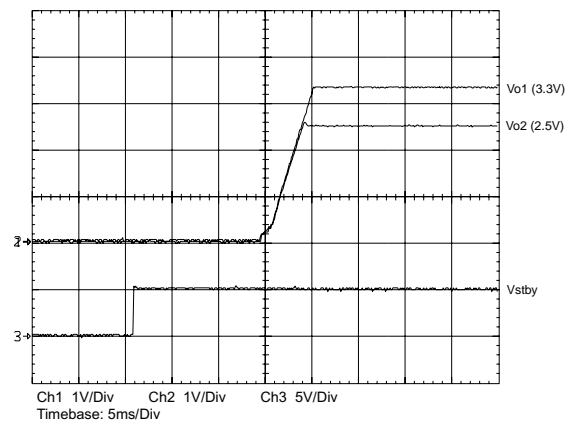

Capacitor Recommendations for the Dual-Output PT6920/30 Regulator Series

Input Capacitors:

The recommended input capacitance is determined by 1.0 ampere minimum ripple current rating and 330µF minimum capacitance (300µF for Oscon® or low ESR tantalum). Ripple current and <100mΩ equivalent series resistance (ESR) values are the major considerations, along with temperature, when designing with different types of capacitors. Tantalum capacitors have a recommended minimum voltage rating of 2 × the maximum DC voltage + AC ripple. This is necessary to insure reliability for input voltage bus applications.

Output Capacitors: C₂(Required), C₃(Optional)

The ESR of the required capacitor (C₂) must not be greater than 150mΩ. Electrolytic capacitors have poor ripple performance at frequencies greater than 400kHz but excellent low frequency transient response. Above the ripple frequency, ceramic capacitors are necessary to improve the transient response and reduce any high frequency noise components apparent during higher current excursions. Preferred low ESR type capacitor part numbers are identified in Table 1. The optional 100µF capacitor (C₃) for Vo₂ can have an ESR of up to 200mΩ for optimum performance and ripple reduction. (Note: Vendor part numbers for the optional capacitor; C₃, are not identified in the table. Use the same series selected for C₂)

Tantalum Capacitors

Tantalum type capacitors can be used for the output but only the AVX TPS series, Sprague 593D/594/595 series or Kemet T495/T510 series. The AVX TPS series, Kemet or Sprague series tantalums are recommended over many other types due to their higher rated surge, power dissipation, and ripple current capability. As a caution the TAJ series by AVX is not recommended. This series has considerably higher ESR, reduced power dissipation and lower ripple current capability. The TAJ Series is a less reliable when compared to the AVX TPS series when determining power dissipation capability. Tantalum types are recommended for applications where ambient temperatures fall below 0°C.

Capacitor Table

Table 1 identifies the characteristics of capacitors from a number of vendors with acceptable ESR and ripple current (rms) ratings. The number of capacitors required at both the input and output buses is identified for each capacitor type.

This is not an extensive capacitor list. Capacitors from other vendors are available with comparable specifications. Those listed are for guidance. The RMS ripple current rating and ESR (Equivalent Series Resistance at 100kHz) are critical parameters necessary to insure both optimum regulator performance and long capacitor life.

Table 1: Input/Output Capacitors

Capacitor Vendor/ Component Series	Capacitor Characteristics					Quantity		Vendor Number
	Working Voltage	Value(µF)	(ESR) Equivalent Series Resistance	85°C Maximum Ripple Current(I _{rms})	Physical Size(mm)	Input Bus	Output Bus	
Panasonic FC	25V	560µF	0.0065W	1205mA	12.5x15	1	1	EEUFCE561S EEUFCEV391S EEUFCEC331
	35V	390µF	0.065W	1205mA	12.5x15	2	1	
	35V	330µF	0.117W	555mA	8x11.5	(a)	1	
United Chemi-con LXV/FS/ LXZ	16V	330µF	0.120W	555mA	8x12	(a)	1	LXZ16VB331M8X12LL LXZ35VB471M10X20LL 10FS330M 20FS150M
	35V	470µF	0.052W	1220mA	10x20	1	1	
	10V	330µF	0.025W	3500mA	10x10.5	1	(N/R)	
	20V	150µF	0.030/2W	3200mA	10x10.5	2	(N/R)	
Nichicon PL PM	35V	560µF	0.048W	1360mA	16x15	1	1	UPL1V561MHH6 UPL1V331MHH6 UPM1H4711MHH6
	35V	330µF	0.065/2W	1020mA	12.5x15	1	1	
	50V	470µF	0.046W	1470mA	18x15	1	1	
Panasonic FC Surface Mtg	10V	1000µF	0.043W	1205mA	12x16.5	1	1	EEVFC1A102LQ EEVFC1V331LQ EEVFC1C331P
	35V	330µF	0.065W	1205mA	12.5x16	1	1	
	16V	330µF	0.150W	670mA	10x10.2	(a)	1	
Oscon- SS SV	10V	330µF	0.025W	>3500mA	10.0x10.5	1	(N/R)	10SS330M 10SV300M 20SV150M SV= Surface Mount
	10V	330µF	0.025W	>3800mA	10.3x10.3	1	(N/R)	
	20V	150µF	0.024/2W	3600mA	10.3x10.3	2	(N/R)	
AVX Tantalum TPS	10V	330µF	0.100/2W	>2500mA	7.3Lx	2	1	TPSV337M010R0100 TPSV337M010R0060 TPSV227M0105R0100
	10V	330µF	0.100/2W	>3000mA	4.3Wx	2	1	
	10V	220µF	0.095W	>2000mA	4.1H	2	2	
Kemet T510 T495	10V	330µF	0.033W	1400mA	7.3Lx5.7W	2	1	T510X337M010AS T495X227M010AS
	10V	220µF	0.070W/2=0.035W	>2000mA	x 4.0H	2	2	
Sprague 594D	10V	330µF	0.0450W	2350mA	7.3Lx	2	1	4D337X0010R2T 594D227X0010D2T
	10V	220µF	0.065W	>2000mA	6.0Wx 4.1H	2	2	

(a) -Not recommended. The maximum ripple current rating of these capacitors does not meet the operating limits.
(N/R) -Oscon Type Capacitors are not recommended for this application due to extremely low equivalent series resistance (ESR)



PACKAGING INFORMATION

Orderable Device	Status ⁽¹⁾	Package Type	Package Drawing	Pins	Package Qty	Eco Plan ⁽²⁾	Lead/Ball Finish	MSL Peak Temp ⁽³⁾
PT6931A	ACTIVE	SIP MOD ULE	ELG	23	10	Pb-Free (RoHS)	Call TI	N / A for Pkg Type
PT6931C	ACTIVE	SIP MOD ULE	ELH	23	10	Pb-Free (RoHS)	Call TI	Level-3-215C-168HRS
PT6931N	ACTIVE	SIP MOD ULE	ELF	23	10	Pb-Free (RoHS)	Call TI	N / A for Pkg Type
PT6932A	ACTIVE	SIP MOD ULE	ELG	23	10	Pb-Free (RoHS)	Call TI	N / A for Pkg Type
PT6932C	ACTIVE	SIP MOD ULE	ELH	23	10	Pb-Free (RoHS)	Call TI	Level-3-215C-168HRS
PT6932N	ACTIVE	SIP MOD ULE	ELF	23	10	Pb-Free (RoHS)	Call TI	N / A for Pkg Type
PT6933A	ACTIVE	SIP MOD ULE	ELG	23	10	Pb-Free (RoHS)	Call TI	N / A for Pkg Type
PT6933C	ACTIVE	SIP MOD ULE	ELH	23	10	Pb-Free (RoHS)	Call TI	Level-3-215C-168HRS

⁽¹⁾ The marketing status values are defined as follows:

ACTIVE: Product device recommended for new designs.

LIFEBUY: TI has announced that the device will be discontinued, and a lifetime-buy period is in effect.

NRND: Not recommended for new designs. Device is in production to support existing customers, but TI does not recommend using this part in a new design.

PREVIEW: Device has been announced but is not in production. Samples may or may not be available.

OBSOLETE: TI has discontinued the production of the device.

⁽²⁾ Eco Plan - The planned eco-friendly classification: Pb-Free (RoHS), Pb-Free (RoHS Exempt), or Green (RoHS & no Sb/Br) - please check <http://www.ti.com/productcontent> for the latest availability information and additional product content details.

TBD: The Pb-Free/Green conversion plan has not been defined.

Pb-Free (RoHS): TI's terms "Lead-Free" or "Pb-Free" mean semiconductor products that are compatible with the current RoHS requirements for all 6 substances, including the requirement that lead not exceed 0.1% by weight in homogeneous materials. Where designed to be soldered at high temperatures, TI Pb-Free products are suitable for use in specified lead-free processes.

Pb-Free (RoHS Exempt): This component has a RoHS exemption for either 1) lead-based flip-chip solder bumps used between the die and package, or 2) lead-based die adhesive used between the die and leadframe. The component is otherwise considered Pb-Free (RoHS compatible) as defined above.

Green (RoHS & no Sb/Br): TI defines "Green" to mean Pb-Free (RoHS compatible), and free of Bromine (Br) and Antimony (Sb) based flame retardants (Br or Sb do not exceed 0.1% by weight in homogeneous material)

⁽³⁾ MSL, Peak Temp. -- The Moisture Sensitivity Level rating according to the JEDEC industry standard classifications, and peak solder temperature.

Important Information and Disclaimer:The information provided on this page represents TI's knowledge and belief as of the date that it is provided. TI bases its knowledge and belief on information provided by third parties, and makes no representation or warranty as to the accuracy of such information. Efforts are underway to better integrate information from third parties. TI has taken and continues to take reasonable steps to provide representative and accurate information but may not have conducted destructive testing or chemical analysis on incoming materials and chemicals. TI and TI suppliers consider certain information to be proprietary, and thus CAS numbers and other limited information may not be available for release.

In no event shall TI's liability arising out of such information exceed the total purchase price of the TI part(s) at issue in this document sold by TI to Customer on an annual basis.

IMPORTANT NOTICE

Texas Instruments Incorporated and its subsidiaries (TI) reserve the right to make corrections, modifications, enhancements, improvements, and other changes to its products and services at any time and to discontinue any product or service without notice. Customers should obtain the latest relevant information before placing orders and should verify that such information is current and complete. All products are sold subject to TI's terms and conditions of sale supplied at the time of order acknowledgment.

TI warrants performance of its hardware products to the specifications applicable at the time of sale in accordance with TI's standard warranty. Testing and other quality control techniques are used to the extent TI deems necessary to support this warranty. Except where mandated by government requirements, testing of all parameters of each product is not necessarily performed.

TI assumes no liability for applications assistance or customer product design. Customers are responsible for their products and applications using TI components. To minimize the risks associated with customer products and applications, customers should provide adequate design and operating safeguards.

TI does not warrant or represent that any license, either express or implied, is granted under any TI patent right, copyright, mask work right, or other TI intellectual property right relating to any combination, machine, or process in which TI products or services are used. Information published by TI regarding third-party products or services does not constitute a license from TI to use such products or services or a warranty or endorsement thereof. Use of such information may require a license from a third party under the patents or other intellectual property of the third party, or a license from TI under the patents or other intellectual property of TI.

Reproduction of TI information in TI data books or data sheets is permissible only if reproduction is without alteration and is accompanied by all associated warranties, conditions, limitations, and notices. Reproduction of this information with alteration is an unfair and deceptive business practice. TI is not responsible or liable for such altered documentation. Information of third parties may be subject to additional restrictions.

Resale of TI products or services with statements different from or beyond the parameters stated by TI for that product or service voids all express and any implied warranties for the associated TI product or service and is an unfair and deceptive business practice. TI is not responsible or liable for any such statements.

TI products are not authorized for use in safety-critical applications (such as life support) where a failure of the TI product would reasonably be expected to cause severe personal injury or death, unless officers of the parties have executed an agreement specifically governing such use. Buyers represent that they have all necessary expertise in the safety and regulatory ramifications of their applications, and acknowledge and agree that they are solely responsible for all legal, regulatory and safety-related requirements concerning their products and any use of TI products in such safety-critical applications, notwithstanding any applications-related information or support that may be provided by TI. Further, Buyers must fully indemnify TI and its representatives against any damages arising out of the use of TI products in such safety-critical applications.

TI products are neither designed nor intended for use in military/aerospace applications or environments unless the TI products are specifically designated by TI as military-grade or "enhanced plastic." Only products designated by TI as military-grade meet military specifications. Buyers acknowledge and agree that any such use of TI products which TI has not designated as military-grade is solely at the Buyer's risk, and that they are solely responsible for compliance with all legal and regulatory requirements in connection with such use.

TI products are neither designed nor intended for use in automotive applications or environments unless the specific TI products are designated by TI as compliant with ISO/TS 16949 requirements. Buyers acknowledge and agree that, if they use any non-designated products in automotive applications, TI will not be responsible for any failure to meet such requirements.

Following are URLs where you can obtain information on other Texas Instruments products and application solutions:

Products

Amplifiers	amplifier.ti.com
Data Converters	dataconverter.ti.com
DLP® Products	www.dlp.com
DSP	dsp.ti.com
Clocks and Timers	www.ti.com/clocks
Interface	interface.ti.com
Logic	logic.ti.com
Power Mgmt	power.ti.com
Microcontrollers	microcontroller.ti.com
RFID	www.ti-rfid.com
RF/IF and ZigBee® Solutions	www.ti.com/lprf

Applications

Audio	www.ti.com/audio
Automotive	www.ti.com/automotive
Broadband	www.ti.com/broadband
Digital Control	www.ti.com/digitalcontrol
Medical	www.ti.com/medical
Military	www.ti.com/military
Optical Networking	www.ti.com/opticalnetwork
Security	www.ti.com/security
Telephony	www.ti.com/telephony
Video & Imaging	www.ti.com/video
Wireless	www.ti.com/wireless

Mailing Address: Texas Instruments, Post Office Box 655303, Dallas, Texas 75265
Copyright © 2009, Texas Instruments Incorporated

www.BDTIC.com/TI