

12-Bit, Quad Channel, 2.7V to 5.5V, DAC in Bumped Die (Wafer Chip Scale) Package—Pb-Free/Green

FEATURES

- Four 12-Bit D/A Converters
- Programmable Settling Time of Either 3 μ s or 9 μ s Typ
- TMS320™ DSP Family, (Q)SPI™, and Microwire™ Compatible Serial Interface
- Internal Power-On Reset
- Low Power Consumption:
 - 8mW, Slow Mode; 5V Supply
 - 3.6mW, Slow Mode; 3V Supply
- Reference Input Buffer
- Voltage Output Range . . . 2x Reference Input Voltage
- Monotonic Over Temperature
- Dual 2.7V to 5.5V Supply (Separate Digital and Analog Supplies)
- Hardware Power-Down (10nA)
- Software Power-Down (10nA)
- Simultaneous Update

APPLICATIONS

- Battery-Powered Test Instruments
- Digital Offset and Gain Adjustment
- Industrial Process Controls
- Machine and Motion Control Devices
- Communications
- Arbitrary Waveform Generation

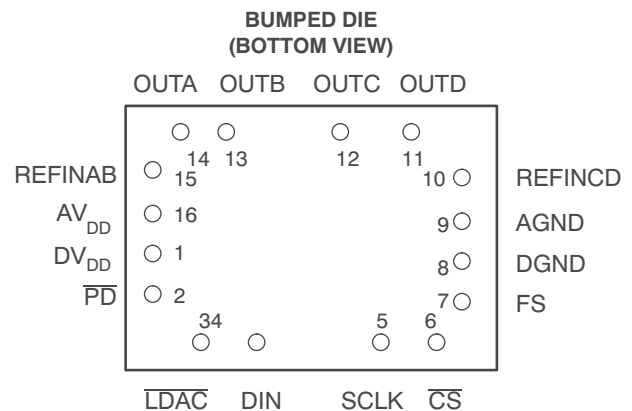

DESCRIPTION

The TLV5614IYZ is a quadruple, 12-bit, voltage output digital-to-analog converter (DAC) with a flexible 4-wire serial interface. The serial interface allows glueless interface to TMS320, SPI, QSPI, and Microwire serial ports. The TLV5614IYZ is programmed with a 16-bit serial word comprised of a DAC address, individual DAC control bits, and a 12-bit DAC value. The device has provision for two supplies: one digital supply for the serial interface (via pins DV_{DD} and DGND), and one for the DACs, reference buffers, and output buffers (via pins AV_{DD} and AGND). Each supply is independent of the other, and can be any value between 2.7V and 5.5V. The dual supplies allow a typical application where the DAC is controlled via a microprocessor operating on a 3V supply (also used on pins DV_{DD} and DGND) with the DACs operating on a 5V supply. Of course, the digital and analog supplies can also be tied together.

The resistor string output voltage is buffered by a 2x gain rail-to-rail output buffer. The buffer features a Class-AB output stage to improve stability and reduce settling time. A rail-to-rail output stage and a power-down mode makes it ideal for single voltage, battery-based applications. The DAC settling time is programmable, allowing the designer to optimize speed versus power dissipation. Settling time is chosen by the control bits within the 16-bit serial input string. A high-impedance buffer is integrated on the REFINAB and REFINCD terminals to reduce the need for a low source impedance drive to the terminal. REFINAB and REFINCD allow DACs A and B to have a different reference voltage than DACs C and D.

The TLV5614IYZ is built with a CMOS process and is available in a 16-terminal bumped die (wafer chip scale) package. It is characterized for operation from –40°C to +85°C in a wire-bonded, small outline (SOIC) package.



Please be aware that an important notice concerning availability, standard warranty, and use in critical applications of Texas Instruments semiconductor products and disclaimers thereto appears at the end of this data sheet.

TMS320 is a trademark of Texas Instruments, Inc.

SPI is a trademark of Motorola, Inc.

Microwire is a trademark of National Semiconductor Corporation.

MCS is a registered trademark of National Semiconductor Corporation.

All other trademarks are the property of their respective owners.



This integrated circuit can be damaged by ESD. Texas Instruments recommends that all integrated circuits be handled with appropriate precautions. Failure to observe proper handling and installation procedures can cause damage.

ESD damage can range from subtle performance degradation to complete device failure. Precision integrated circuits may be more susceptible to damage because very small parametric changes could cause the device not to meet its published specifications.

PACKAGE/ORDERING INFORMATION

For the most current package and ordering information, see the Package Option Addendum at the end of this document, or see the TI web site at www.ti.com.

ABSOLUTE MAXIMUM RATINGS

Over operating free-air temperature range (unless otherwise noted)⁽¹⁾

	UNIT
Supply voltage, (DV _{DD} , AV _{DD} to GND)	7V
Supply voltage difference, (AV _{DD} to DV _{DD})	–2.8V to 2.8V
Digital input voltage range	–0.3V to DV _{DD} + 0.3V
Reference input voltage range	–0.3V to AV _{DD} + 0.3V
Operating free-air temperature range, T _A	–40°C to +85°C

(1) Stresses beyond those listed under *absolute maximum ratings* may cause permanent damage to the device. These are stress ratings only, and functional operation of the device at these or any other conditions beyond those indicated under *recommended operating conditions* is not implied. Exposure to absolute-maximum-rated conditions for extended periods may affect device reliability.

RECOMMENDED OPERATING CONDITIONS

Over operating free-air temperature range (unless otherwise noted)

		MIN	NOM	MAX	UNIT
Supply voltage, AV _{DD} , DV _{DD}	5V supply	4.5	5	5.5	V
	3V supply	2.7	3	3.3	
High-level digital input voltage, V _{IH}	DV _{DD} = 2.7V	2			V
	DV _{DD} = 5.5V	2.4			
Low-level digital input voltage, V _{IL}	DV _{DD} = 2.7V			0.6	V
	DV _{DD} = 5.5V			1	
Reference voltage, V _{REF} to REFINAB, REFINCD terminal	5V supply ⁽¹⁾	0	2.048	V _{DD} – 1.5	V
	3V supply ⁽¹⁾	0	1.024	V _{DD} – 1.5	
Load resistance, R _L		2	10		kΩ
Load capacitance, C _L				100	pF
Serial clock rate, SCLK				20	MHz
Operating free-air temperature	TLV5614IYZ	–40		+85	°C

(1) Voltages greater than AV_{DD}/2 cause output saturation for upper DAC codes.

ELECTRICAL CHARACTERISTICS

Over operating free-air temperature range, supply voltages, and reference voltages (unless otherwise noted).

PARAMETER		TEST CONDITIONS	MIN	TYP	MAX	UNIT
STATIC DAC SPECIFICATIONS						
Resolution			12			bits
Integral nonlinearity (INL), end point adjusted		See ⁽¹⁾		±1.5	±4	LSB
Differential nonlinearity (DNL)		See ⁽²⁾		±0.5	±1	LSB
E _{ZS}	Zero-scale error (offset error at zero scale)	See ⁽³⁾			±12	mV
Zero-scale error temperature coefficient		See ⁽⁴⁾		10		ppm/°C
E _G	Gain error	See ⁽⁵⁾			±0.6	% of FS voltage
Gain error temperature coefficient		See ⁽⁶⁾		10		ppm/°C
PSRR	Power supply rejection ratio	Zero scale	See ⁽⁷⁾⁽⁸⁾			dB
		Full scale				dB
INDIVIDUAL DAC OUTPUT SPECIFICATIONS						
V _O	Voltage output range	R _L = 10kΩ	0		AV _{DD} – 0.4	V
Output load regulation accuracy		R _L = 2kΩ vs 10kΩ		0.1	0.25	% of FS voltage
REFERENCE INPUTS (REFINAB, REFINCD)						
V _I	Input voltage range	See ⁽⁹⁾	0		AV _{DD} – 1.5	V
R _I	Input resistance			10		MΩ
C _I	Input capacitance			5		pF
Reference feedthrough		REFIN = 1V _{PP} at 1kHz + 1.024V _{DC} (see ⁽¹⁰⁾)			–75	dB
Reference input bandwidth		REFIN = 0.2V _{PP} + 1.024V _{DC} large signal	Slow	0.5		MHz
			Fast	1		
DIGITAL INPUTS (DIN, CS, LDAC, PD)						
I _{IH}	High-level digital input current	V _I = V _{DD}			±1	μA
I _{IL}	Low-level digital input current	V _I = 0V			±1	μA
C _I	Input capacitance			3		pF
POWER SUPPLY						
I _{DD}	Power supply current	5V supply, no load, clock running. All inputs 0V or V _{DD}	Slow	1.6	2.4	mA
			Fast	3.8	5.6	
		3V supply, no load, clock running. All inputs 0V or DV _{DD}	Slow	1.2	1.8	mA
			Fast	3.2	4.8	
Power down supply current (see Figure 12)				10		nA

- (1) The relative accuracy or integral nonlinearity (INL), sometimes referred to as *linearity error*, is the maximum deviation of the output from the line between zero and full-scale excluding the effects of zero code and full-scale errors.
- (2) The differential nonlinearity (DNL), sometimes referred to as *differential error*, is the difference between the measured and ideal 1 LSB amplitude change of any two adjacent codes. *Monotonic* means the output voltage changes in the same direction (or remains constant) as a change in the digital input code.
- (3) Zero-scale error is the deviation from zero voltage output when the digital input code is zero.
- (4) Zero-scale error temperature coefficient is given by: $E_{ZS} TC = [E_{ZS}(T_{MAX}) - E_{ZS}(T_{MIN})]/V_{REF} \times 10^6/(T_{MAX} - T_{MIN})$.
- (5) Gain error is the deviation from the ideal output (2V_{REF} – 1 LSB) with an output load of 10 kΩ excluding the effects of the zero error.
- (6) Gain temperature coefficient is given by: $E_G TC = [E_G(T_{MAX}) - E_G(T_{MIN})]/V_{REF} \times 10^6/(T_{MAX} - T_{MIN})$.
- (7) Zero-scale error rejection ratio (E_{ZS}–RR) is measured by varying the AV_{DD} from 5V ± 0.5V and 3V ± 0.3V_{DC}, and measuring the proportion of this signal imposed on the zero-code output voltage.
- (8) Full-scale rejection ratio (E_G–RR) is measured by varying the AV_{DD} from 5V ± 0.5V and 3V ± 0.3V_{DC} and measuring the proportion of this signal imposed on the full-scale output voltage after subtracting the zero scale change.
- (9) Reference input voltages greater than V_{DD}/2 cause output saturation for upper DAC codes.
- (10) Reference feedthrough is measured at the DAC output with an input code = 000hex and V_{REF} (REFINAB or REFINCD) input = 1.024V_{DC} + 1V_{PP} at 1kHz.

ELECTRICAL CHARACTERISTICS (continued)

Over operating free-air temperature range, supply voltages, and reference voltages (unless otherwise noted).

PARAMETER		TEST CONDITIONS	MIN	TYP	MAX	UNIT
ANALOG OUTPUT DYNAMIC PERFORMANCE						
SR	Output slew rate	$C_L = 100\text{pF}$, $R_L = 10\text{k}\Omega$, $V_O = 10\%$ to 90% , $V_{REF} = 2.048\text{V}$, 1024V	Fast	5		V/ μs
			Slow	1		V/ μs
t_s	Output settling time	$T_o \pm 0.5 \text{ LSB}$, $C_L = 100\text{pF}$, $R_L = 10\text{k}\Omega$, see (11)(12)	Fast	3	5.5	μs
			Slow	9	20	
$t_{s(c)}$	Output settling time, code to code	$T_o \pm 0.5 \text{ LSB}$, $C_L = 100\text{pF}$, $R_L = 10\text{k}\Omega$, see (13)	Fast	1		μs
			Slow	2		
Glitch energy		Code transition from 7FF to 800		10		nV-s
SNR	Signal-to-noise ratio	Sinewave generated by DAC, Reference voltage = 1.024 at 3V and 2.048 at 5V, $f_S = 400\text{KSPS}$, $f_{OUT} =$ 1.1kHz sinewave, $C_L = 100\text{pF}$, $R_L = 10\text{k}\Omega$, BW = 20kHz		74		dB
SINAD	Signal to noise + distortion			66		
THD	Total harmonic distortion			-68		
SFDR	Spurious-free dynamic range			70		
DIGITAL INPUT TIMING REQUIREMENTS						
$t_{su(CS-FS)}$	Setup time, \overline{CS} low before FS \downarrow		10			ns
$t_{su(FS-CK)}$	Setup time, FS low before first negative SCLK edge		8			ns
$t_{su(C16-FS)}$	Setup time. 16th negative SCLK edge after FS low on which bit D0 is sampled before rising edge of FS		10			ns
$t_{su(C16-CS)}$	Setup time. The first positive SCLK edge after D0 is sampled before \overline{CS} rising edge. If FS is used instead of the SCLK positive edge to update the DAC, then the setup time is between the FS rising edge and \overline{CS} rising edge.		10			ns
t_{wH}	Pulse duration, SCLK high		25			ns
t_{wL}	Pulse duration, SCLK low		25			ns
$t_{su(D)}$	Setup time, data ready before SCLK falling edge		8			ns
$t_{h(D)}$	Hold time, data held valid after SCLK falling edge		5			ns
$t_{wH(FS)}$	Pulse duration, FS high		20			ns

- (11) Settling time is the time for the output signal to remain within $\pm 0.5 \text{ LSB}$ of the final measured value for a digital input code change of FFFhex to 080hex for 080hex to FFFhex.
- (12) Limits are ensured by design and characterization, but are not production tested.
- (13) Settling time is the time for the output signal to remain within $\pm 0.5 \text{ LSB}$ of the final measured value for a digital input code change of one count.

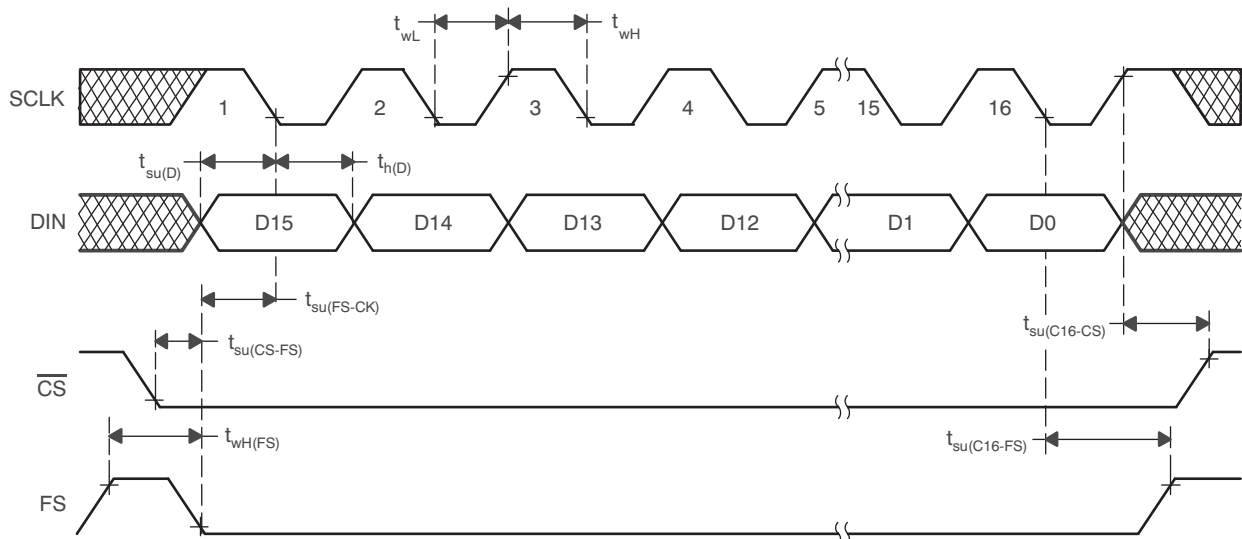

Figure 1. Timing Diagram

FUNCTIONAL BLOCK DIAGRAM

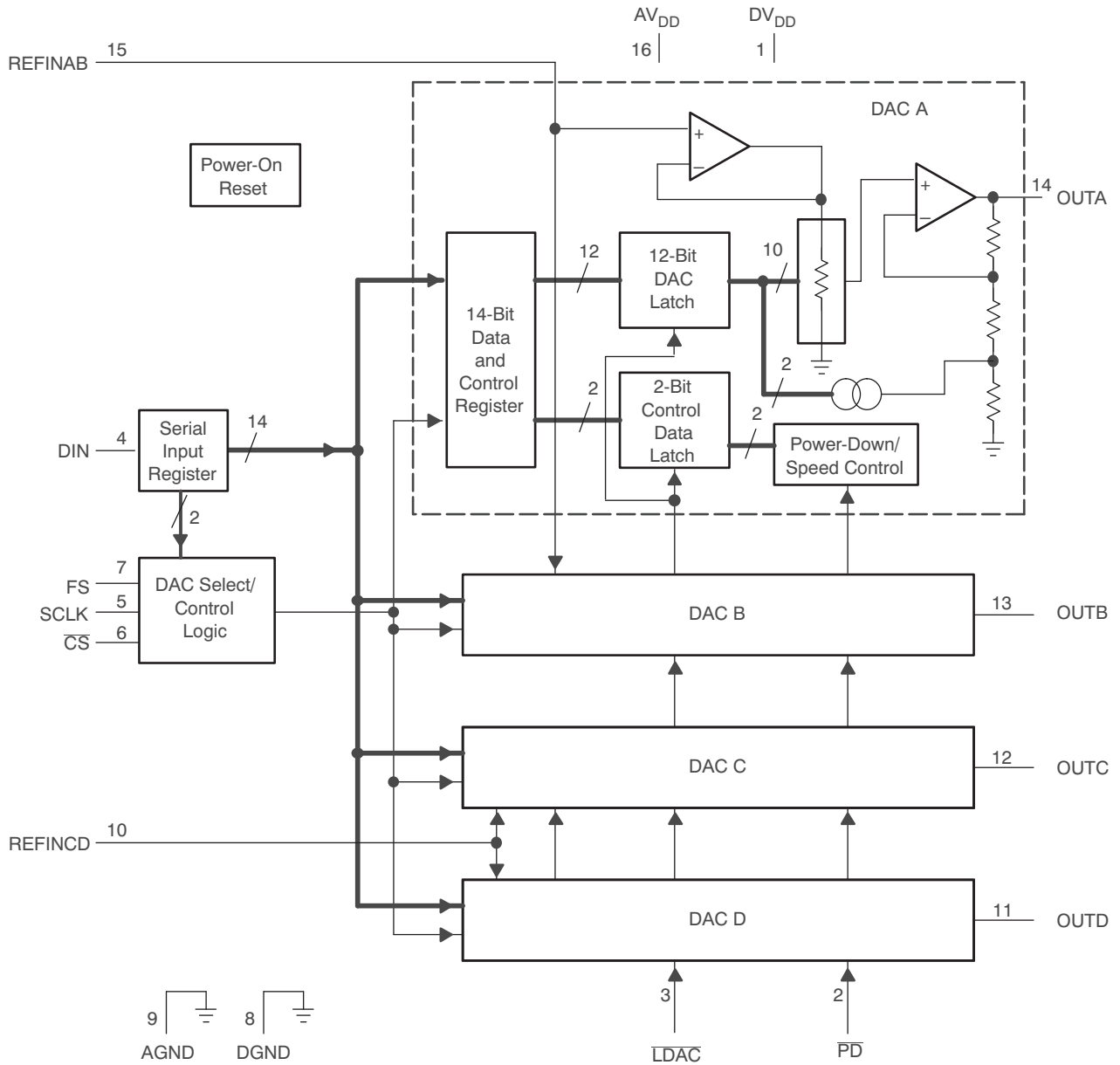
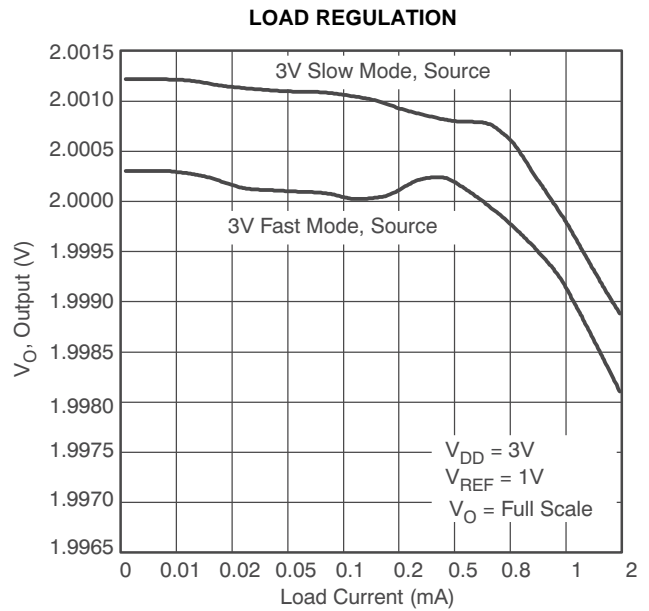
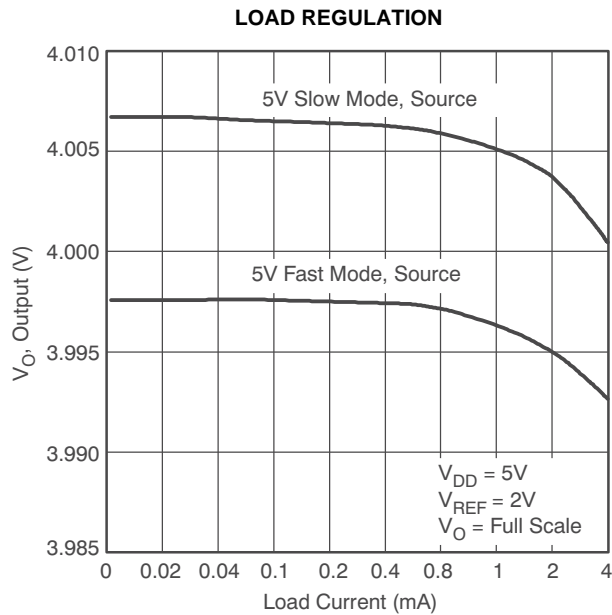
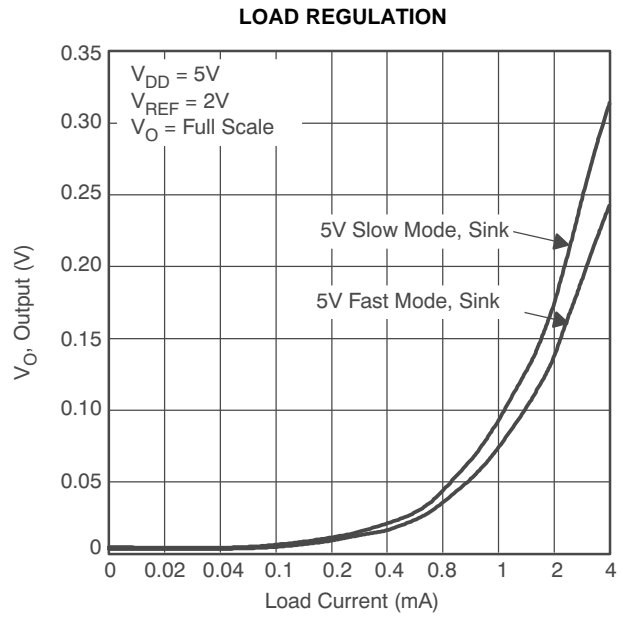
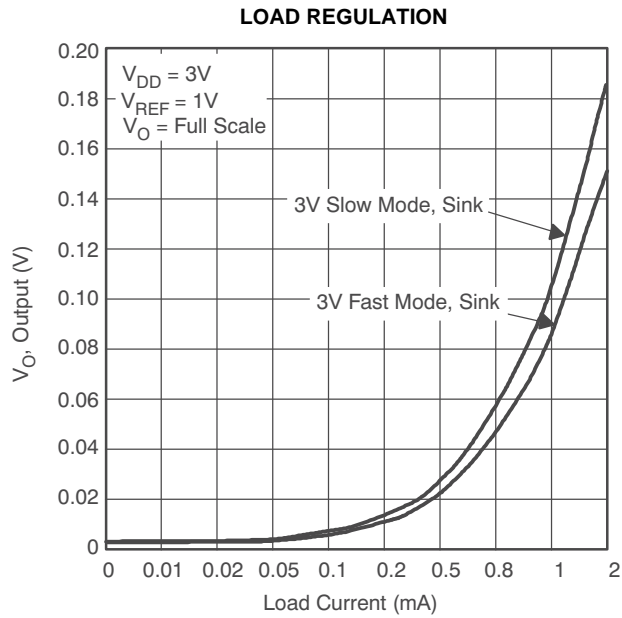

Table 1. TERMINAL FUNCTIONS

TERMINAL		I/O	DESCRIPTION
NAME	NO.		
AGND	9	—	Analog ground
AV _{DD}	16	—	Analog supply
\overline{CS}	6	I	Chip select. This terminal is active low.
DGND	8	—	Digital ground
DIN	4	I	Serial data input
DV _{DD}	1	—	Digital supply
FS	7	I	Frame sync input. The falling edge of the frame sync pulse indicates the start of a serial data frame shifted out to the TLV5614IYZ.
\overline{PD}	2	I	Power-down pin. Powers down all DACs (overriding the individual power down settings), and all output stages. This terminal is active low.
\overline{LDAC}	3	I	Load DAC. When the \overline{LDAC} signal is high, no DAC output updates occur when the input digital data is read into the serial interface. The DAC outputs are only updated when \overline{LDAC} is low.
REFINAB	15	I	Voltage reference input for DACs A and B.
REFINCD	10	I	Voltage reference input for DACs C and D.
SCLK	5	I	Serial clock inputinput
OUTA	14	O	DACA output
OUTB	13	O	DACB output
OUTC	12	O	DACC output
OUTD	11	O	DACD output

TYPICAL CHARACTERISTICS



TYPICAL CHARACTERISTICS (continued)

SUPPLY CURRENT vs TEMPERATURE

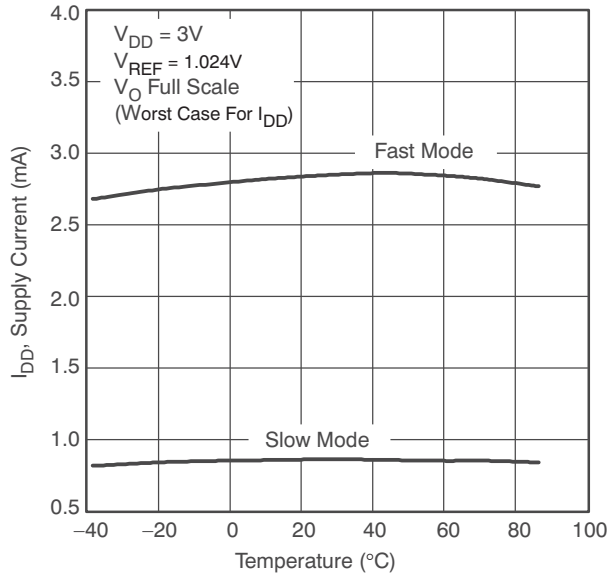

SUPPLY CURRENT vs TEMPERATURE

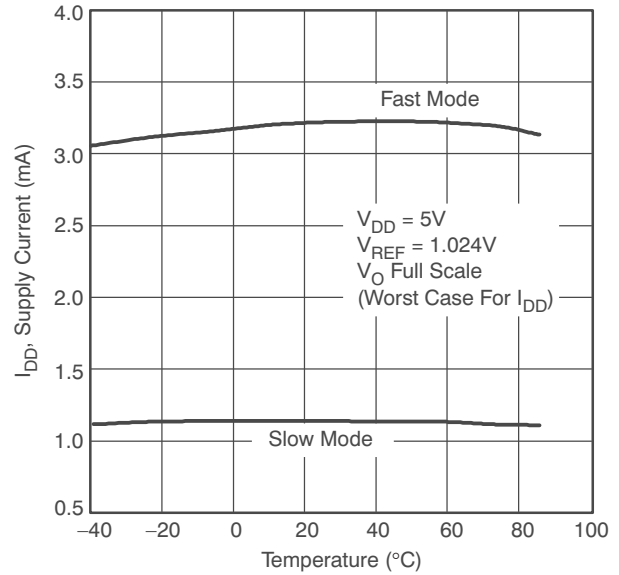

TOTAL HARMONIC DISTORTION vs FREQUENCY

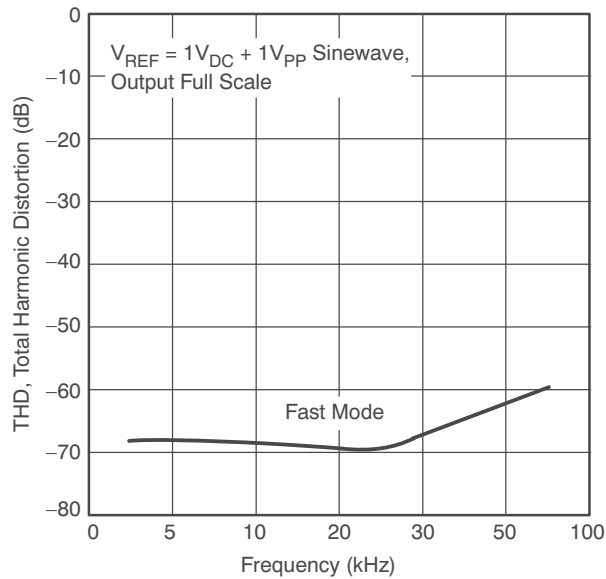

TOTAL HARMONIC DISTORTION vs FREQUENCY

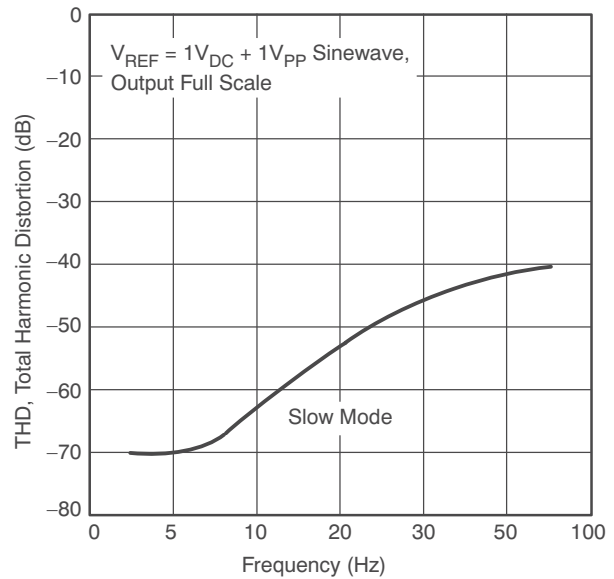

TYPICAL CHARACTERISTICS (continued)

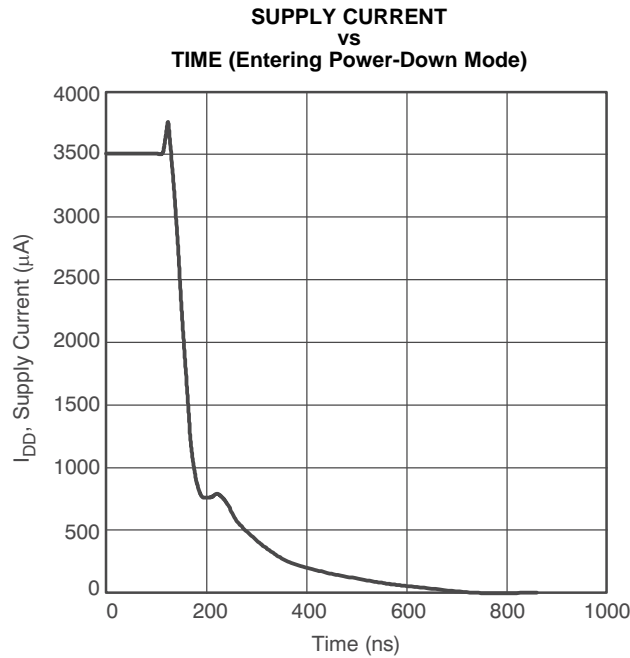
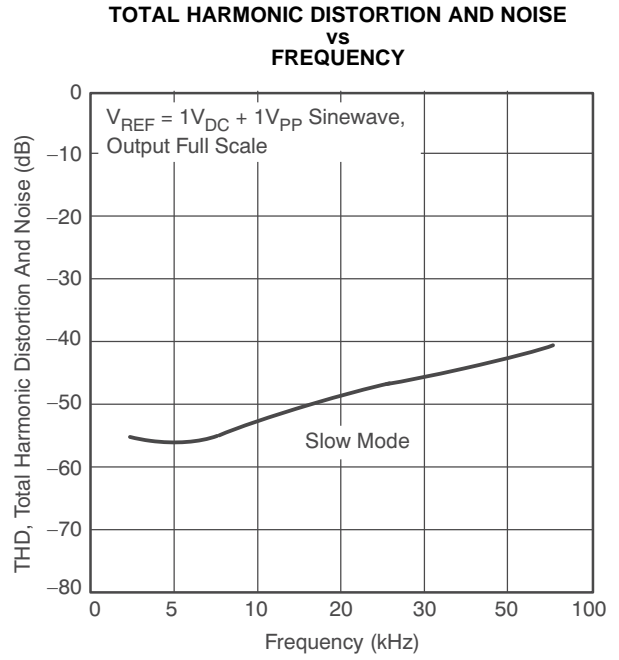
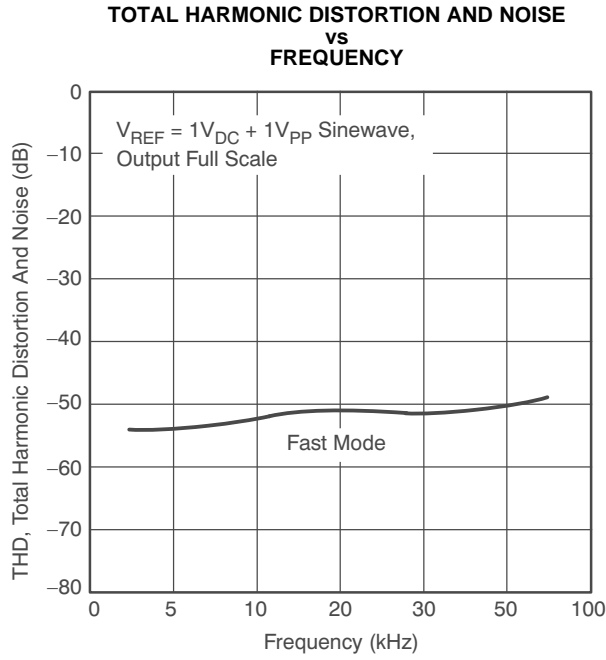

TYPICAL CHARACTERISTICS (continued)

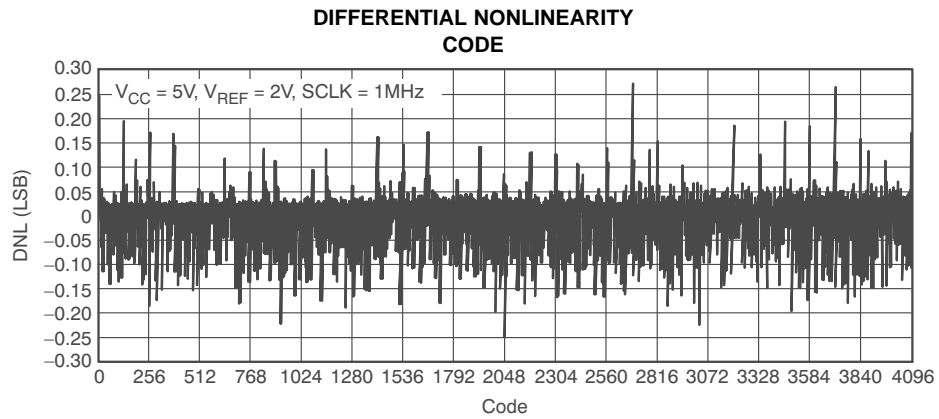

Figure 13.

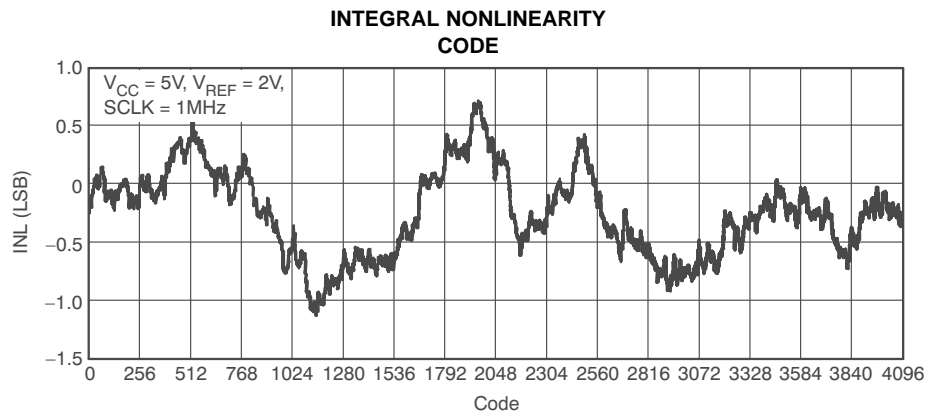

Figure 14.

APPLICATION INFORMATION

GENERAL FUNCTION

The TLV5614IYZ is a 12-bit, single-supply DAC based on a resistor string architecture. The device consists of a serial interface, speed and power-down control logic, a reference input buffer, a resistor string, and a rail-to-rail output buffer.

The output voltage (full-scale determined by external reference) is given by:

$$2 \text{ REF} \frac{\text{CODE}}{2^n} [V]$$

where REF is the reference voltage and CODE is the digital input value within the range of 0_{10} to $(2^n - 1)$, where $n = 12$ (bits). The 16-bit data word, consisting of control bits and the new DAC value, is described in the data format section. A power-on reset initially resets the internal latches to a defined state (all bits '0').

SERIAL INTERFACE

Data transfer occurs in this manner: First, the device must be enabled with $\overline{\text{CS}}$ set low. Then, a falling edge of FS starts shifting the data bit-per-bit (starting with the MSB) to the internal register on the falling edges of SCLK. After 16 bits have been transferred or FS rises, the content of the shift register is moved to the DAC latch, which then updates the voltage output to the new level.

The serial interface of the TLV5614IYZ can be used in two basic modes:

- Four-wire (with chip-select)
- Three-wire (without chip-select)

Using chip-select (four-wire mode), it is possible to have more than one device connected to the serial port of the data source (a DSP or microcontroller). The interface is compatible with the TMS320 DSP family. Figure 15 shows an example with two TLV5614IYZs connected directly to a TMS320 DSP.

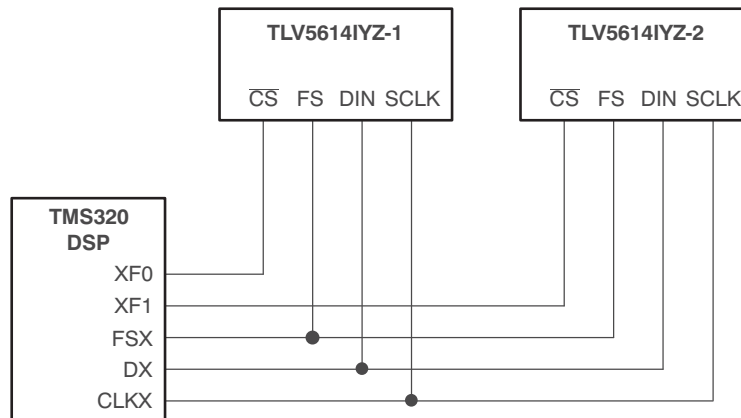

Figure 15. TMS320 Interface

If there is no need to have more than one device on the serial bus, then $\overline{\text{CS}}$ can be tied low. Figure 16 shows an example of how to connect the TLV5614IYZ to a TMS320, SPI, or Microwire port using only three pins.

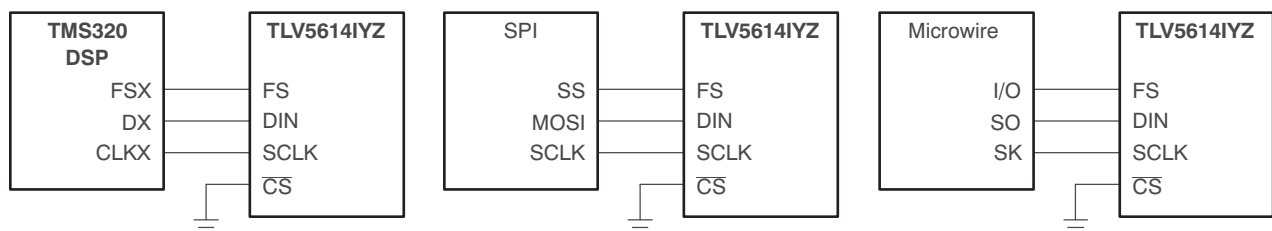

Figure 16. Three-Wire Interface

APPLICATION INFORMATION (continued)

Notes on SPI and Microwire connections: Before the controller starts the data transfer, the software must generate a falling edge on the I/O pin connected to FS. If the word width is eight bits (SPI and Microwire), two write operations must be performed to program the TLV5614IYZ. After the write operation(s), the DAC output is updated automatically on the next positive clock edge following the 16th falling clock edge.

SERIAL CLOCK FREQUENCY AND UPDATE RATE

The maximum serial clock frequency is given by:

$$f_{SCLKmax} = \frac{1}{t_{wH(min)} + t_{wL(min)}} = 20 \text{ MHz}$$

The maximum update rate is:

$$f_{UPDATEmax} = \frac{1}{16 (t_{wH(min)} + t_{wL(min)})} = 1.25 \text{ MHz}$$

Note that the maximum update rate is a theoretical value for the serial interface, because the settling time of the TLV5614IYZ must also be considered.

DATA FORMAT

The 16-bit data word for the TLV5614IYZ consists of two parts:

- Control bits (D15 . . . D12)
- New DAC value (D11 . . . D0)

D15	D14	D13	D12	D11	D10	D9	D8	D7	D6	D5	D4	D3	D2	D1	D0
A3	A2	A1	A0	New DAC value (12 bits)											

X: don't care

SPD: Speed control bit. 1→fast mode, 0→slow mode

PWR: Power control bit. 1→power down, 0→normal operation

In power-down mode, all amplifiers within the TLV5614IYZ are disabled. A particular DAC (A, B, C, D) of the TLV5614IYZ is selected by A1 and A0 within the input word.

A1	A0	DAC
0	0	A
0	1	B
1	0	C
1	1	D

TLV5614IYZ INTERFACED TO TMS320C203 DSP

Hardware Interfacing

Figure 17 shows an example of how to connect the TLV5614IYZ to a TMS320C203 DSP. The serial port is configured in burst mode, with FSX generated by the TMS320C203 to provide the frame sync (FS) input to the TLV5614IYZ. Data is transmitted on the DX line, with the serial clock input on the CLKX line. The general-purpose input/output port bits IO0 and IO1 are used to generate the chip select (\overline{CS}) and DAC latch update (\overline{LDAC}) inputs to the TLV5614IYZ. The active low power-down (\overline{PD}) is pulled high all the time to ensure the DACs are enabled.

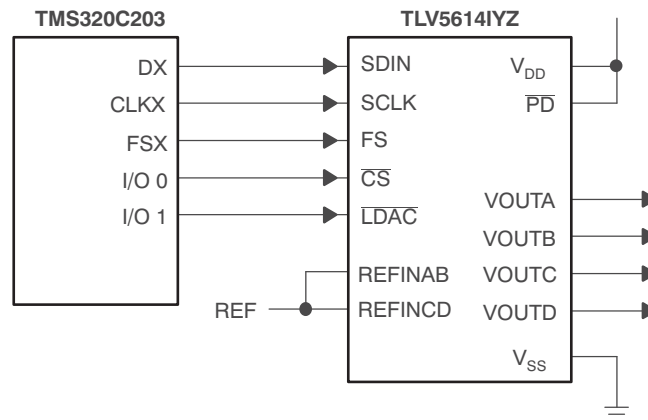

Figure 17. TLV5614IYZ Interfaced With TMS320C203

Software

The application example outputs a differential in-phase (sine) signal between the VOUTA and VOUTB pins, and its quadrature (cosine) signal as the differential signal between VOUTC and VOUTD.

The on-chip timer is used to generate interrupts at a fixed frequency. The related interrupt service routine pulses \overline{LDAC} low to update all four DACs simultaneously, then fetches and writes the next sample to all four DACs. The samples are stored in a look-up table that describes two full periods of a sine wave.

The synchronous serial port of the DSP is used in burst mode. In this mode, the processor generates an FS pulse preceding the MSB of every data word. If multiple, contiguous words are transmitted, a violation of the $t_{su}(C16-FS)$ timing requirement occurs. To avoid this violation, the program waits until the transmission of the previous word has been completed.

```

;.....
; Processor: TMS320C203 running at 40 MHz
;
; Description:
;
; This program generates a differential in-phase (sine) on (OUTA-OUTB) and its quadrature
(cosine) as a differential signal on (OUTC-OUTD).
;
; The DAC codes for the signal samples are stored as a table of 64 12-bit values, describing
; 2 periods of a sine function. A rolling pointer is used to address the table location in
; the first period of this waveform, from which the DAC A samples are read. The samples for
; the other 3 DACs are read at an offset to this rolling pointer
; DAC Function Offset from rolling pointer
; A sine 0
; B inverse sine 16
; C cosine 8
; D inverse cosine24
;
; The on-chip timer is used to generate interrupts at a fixed rate. The interrupt service
; routine first pulses LDAC low to update all DACs simultaneously with the values which
; were written to them in the previous interrupt. Then all 4 DAC values are fetched and
; written out through the synchronous serial interface. Finally, the rolling pointer is
; incremented to address the next sample, ready for the next interrupt.
  
```

```

; © 1998, Texas Instruments Inc.
;.....

;----- I/O and memory mapped regs -----
.include "regs.asm"
;----- jump vectors -----
.ps 0h
b start
b int1
b int23
b timer_isr;
----- variables -----
temp .equ 0060h
r_ptr .equ 0061h
iosr_stat .equ 0062h
DACA_ptr .equ 0063h
DACb_ptr .equ 0064h
DACC_ptr .equ 0065h
DACd_ptr .equ 0066h
;----- constants -----
; DAC control bits to be OR'ed onto data
; all fast mode
DACA_control .equ 01000h
DACb_control .equ 05000h
DACC_control .equ 09000h
DACd_control .equ 0d000h
;----- tables -----
.ds 02000h
sinevals
.word 00800h
.word 0097Ch
.word 00AE9h
.word 00C3Ah
.word 00D61h
.word 00E53h
.word 00F07h
.word 00F76h
.word 00F9Ch
.word 00F76h
.word 00F07h
.word 00E53h
.word 00D61h
.word 00C3Ah
.word 00AE9h
.word 0097Ch
.word 00800h
.word 00684h
.word 00517h
.word 003C6h
.word 0029Fh
.word 001ADh
.word 000F9h
.word 0008Ah
.word 00064h
.word 0008Ah
.word 000F9h
.word 001ADh
.word 0029Fh
.word 003C6h
.word 00517h
.word 00684h
.word 00800h
.word 0097Ch
.word 00AE9h
.word 00C3Ah
.word 00D61h
.word 00E53h
.word 00F07h
.word 00F76h
.word 00F9Ch
.word 00F76h
.word 00F07h

```

```

.word 00E53h
.word 00D61h
.word 00C3Ah
.word 00AE9h
.word 0097Ch
.word 00800h
.word 00684h
.word 00517h
.word 003C6h
.word 0029Fh
.word 001ADh
.word 000F9h
.word 0008Ah
.word 00064h
.word 0008Ah
.word 000F9h
.word 001ADh
.word 0029Fh
.word 003C6h
.word 00517h
.word 00684h
;
;-----
; Main Program
;-----
.ps 1000h
.entry
start
;-----
; disable interrupts
;-----
setc INTM ; disable maskable interrupts
splk #0ffffh, IFR; clear all interrupts
splk #0004h, IMR; timer interrupts unmasked
;-----
; set up the timer
; timer period set by values in PRD and TDDR
; period = (CLKOUT1 period) × (1+PRD) × (1+TDDR)
; examples for TMS320C203 with 40MHz main clock
; Timer rate TDDR PRD
; 80 kHz 9 24 (18h)
; 50 kHz 9 39 (27h)
;-----
prd_val.equ 0018h
tcr_val.equ 0029h
splk #0000h, temp; clear timer
out temp, TIM
splk #prd_val, temp; set PRD
out temp, PRD
splk #tcr_val, temp; set TDDR, and TRB=1 for auto-reload
out temp, TCR
;-----
; Configure IO0/1 as outputs to be :
; IO0 CS - and set high
; IO1 LDAC - and set high
;-----
in temp, ASPCR; configure as output
lacl temp
or #0003h
sacl temp
out temp, ASPCR
in temp, IOSR; set them high
lacl temp
or #0003h
sacl temp
out temp, IOSR
;-----
; set up serial port for
; SSPCR.TXM=1 Transmit mode - generate FSX
; SSPCR.MCM=1 Clock mode - internal clock source
; SSPCR.FSM=1 Burst mode
;-----
splk #0000Eh, temp

```

```

out temp, SSPCR; reset transmitter
splk #0002Eh, temp
out temp, SSPCR
;-----
; reset the rolling pointer
;-----
lacl #000h
sacl r_ptr
;-----
; enable interrupts
;-----
clrc INTM ; enable maskable interrupts
;-----
; loop forever!
;-----
next idle ;wait for interrupt
b next
;-----
;all else fails stop here
;-----
done b done ;hang there
;-----
; Interrupt Service Routines
;-----
int1 ret ; do nothing and return
int23 ret ; do nothing and return
timer_isr:
in iosr_stat, IOSR; store IOSR value into variable space
lacl iosr_stat ; load acc with iosr status
and #0FFFDh ; reset IO1 - LDAC low
sacl temp ;
out temp, IOSR;
or #0002h ; set IO1 - LDAC high
sacl temp ;
out temp, IOSR;
and #0FFFEh ; reset IO0 - CS low
sacl temp ;
out temp, IOSR;
lacl r_ptr ; load rolling pointer to accumulator
add #sinevals ; add pointer to table start
sacl DACa_ptr ; to get a pointer for next DAC a sample
add #08h ; add 8 to get to DAC C pointer
sacl DACc_ptr
add #08h ; add 8 to get to DAC B pointer
sacl DACb_ptr
add #08h ; add 8 to get to DAC D pointer
sacl DACd_ptr
mar *,ar0 ; set ar0 as current AR
; DAC A
lar ar0, DACa_ptr ; ar0 points to DAC a sample
lacl * ; get DAC a sample into accumulator
or #DACa_control ; OR in DAC A control bits
sacl temp ;
out temp, SDTR; send data
;-----
We must wait for transmission to complete before writing next word to the SDTR.;
TLV5614/04 interface does not allow the use of burst mode with the full packet; rate, as
we need a CLKX -ve edge to clock in last bit before FS goes high again,; to allow SPI
compatibility.
;-----
rpt #016h ; wait long enough for this configuration
nop ; of MCLK/CLKOUT1 rate
; DAC B
lar ar0, dacb_ptr ; ar0 points to DAC a sample
lacl * ; get DAC a sample into accumulator
or #DACb_control ; OR in DAC B control bits
sacl temp ;
out temp, SDTR; send data
rpt #016h ; wait long enough for this configuration
nop ; of MCLK/CLKOUT1 rate
; DAC C
lar ar0, dacc_ptr ; ar0 points to dac a sample

```



```

lacl * ; get DAC a sample into accumulator
or #DACc_control ; OR in DAC C control bits
sacl temp ;
out temp, SDTR; send data
rpt #016h ; wait long enough for this configuration
nop ; of MCLK/CLKOUT1 rate
; DAC D
lar ar0, dacd_ptr; ar0 points to DAC a sample
lacl * ; get DAC a sample into accumulator
or #dacd_control ; OR in DAC D control bits
sacl temp ;
out temp, SDTR; send data
lacl r_ptr ; load rolling pointer to accumulator
add #1h ; increment rolling pointer
and #001Fh ; count 0-31 then wrap back round
sacl r_ptr ; store rolling pointer
rpt #016h ; wait long enough for this configuration
nop ; of MCLK/CLKOUT1 rate
; now take CS high again
lacl iosr_stat ; load acc with iosr status
or #0001h ; set IO0 - CS high
sacl temp ;
out temp, IOSR;
clrc intm ; re-enable interrupts
ret ; return from interrupt
.end
  
```

TLV5614IYZ INTERFACED TO MCS[®]51 MICROCONTROLLER

Hardware Interfacing

Figure 18 shows an example of how to connect the TLV5614IYZ to an MCS51 Microcontroller. The serial DAC input data and external control signals are sent via I/O Port 3 of the controller. The serial data is sent on the RxD line, with the serial clock output on the TxD line. Port 3 bits 3, 4, and 5 are configured as outputs to provide the DAC latch update ($\overline{\text{LDAC}}$), chip select ($\overline{\text{CS}}$) and frame sync (FS) signals for the TLV5614IYZ. The active low power-down pin ($\overline{\text{PD}}$) of the TLV5614IYZ is pulled high to ensure that the DACs are enabled.

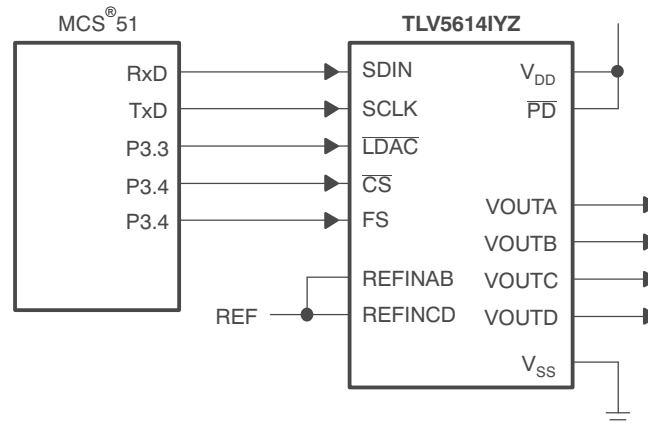

Figure 18. TLV5614IYZ Interfaced With MCS51

Software

The example is the same as for the TMS320C203 in this data sheet, but adapted for a MCS51 controller. It generates a differential in-phase (sine) signal between the VOUTA and VOUTB pins, and its quadrature (cosine) signal is the differential signal between VOUTC and VOUTD.

The on-chip timer is used to generate interrupts at a fixed frequency. The related interrupt service routine pulses $\overline{\text{LDAC}}$ low to update all four DACs simultaneously, then fetches and writes the next sample to all four DACs. The samples are stored as a look-up table, that describes one full period of a sine wave.

The serial port of the controller is used in Mode 0, which transmits eight bits of data on RxD, accompanied by a synchronous clock on TxD. Two writes concatenated together are required to write a complete word to the TLV5614IYZ. The \overline{CS} and FS signals are provided in the required fashion through control of IO port 3, which has bit-addressable outputs.

```

Processor: 80C51
;
; Description:
;
; This program generates a differential in-phase
(sine) on (OUTA-OUTB) ; and its quadrature (cosine)
as a differential signal on (OUTC-OUTD).
;
; © 1998, Texas Instruments Inc.
;-----

NAME GENIQ
MAIN SEGMENT CODE
ISR SEGMENT CODE
SINTBL SEGMENT CODE
VAR1 SEGMENT DATA
STACK SEGMENT IDATA
;-----
; Code start at address 0, jump to start
;-----
CSEG AT 0
LJMP start ; Execution starts at address 0 on power-up.
;-----
; Code in the timer0 interrupt vector
;-----
CSEG AT 0BH
LJMP timer0isr ; Jump vector for timer 0 interrupt is 000Bh
;-----
; Global variables need space allocated
;-----
RSEG VAR1
temp_ptr: DS 1
rolling_ptr: DS 1
;-----
; Interrupt service routine for timer 0 interrupts
;-----
RSEG ISR
timer0isr:
PUSH PSW
PUSH ACC
CLR INT1 ; pulse LDAC low
SETB INT1 ; to latch all 4 previous values at the same time
; 1st thing done in timer isr => fixed period
CLR T0 ; set CS low
; The signal to be output on each DAC is a sine function. One cycle of a sine wave is
; held in a table @ sinevals as 32 samples of msb, lsb pairs (64 bytes).
; We have ; one pointer which rolls round this table, rolling_ptr incrementing by
; 2 bytes (1 sample) on each interrupt (at the end of this routine).
; The DAC samples are read at an offset to this rolling pointer:
; DAC Function Offset from rolling_ptr
; A sine 0
; B inverse sine 32
; C cosine 16
; D inverse cosine48
MOV DPTR,#sinevals; set DPTR to the start of the table of sine signal values
MOV R7,rolling_ptr; R7 holds the pointer into the sine table
MOV A,R7 ; get DAC A msb
MOVC A,@A+DPTR ; msb of DAC A is in the ACC
CLR T1 ; transmit it - set FS low
MOV SBUF,A ; send it out the serial port
INC R7 ; increment the pointer in R7
MOV A,R7 ; to get the next byte from the table
MOVC A,@A+DPTR ; which is the lsb of this sample, now in ACC
A_MSB_TX:
JNB TI,A_MSB_TX ; wait for transmit to complete
CLR TI ; clear for new transmit

```

```

MOV SBUF,A ; and send out the lsb of DAC A
; DAC C next
; DAC C codes should be taken from 16 bytes (8 samples) further on
; in the sine table - this gives a cosine function
MOV A,R7 ; pointer in R7
ADD A,#0FH ; add 15 - already done one INC
ANL A,#03FH ; wrap back round to 0 if > 64
MOV R7,A ; pointer back in R7
MOVC A,@A+DPTR ; get DAC C msb from the table
ORL A,#01H ; set control bits to DAC C address
A_LSB_TX:
JNB TI,A_LSB_TX ; wait for DAC A lsb transmit to complete
SETB T1 ; toggle FS
CLR T1
CLR TI ; clear for new transmit
MOV SBUF,A ; and send out the msb of DAC C
INC R7 ; increment the pointer in R7
MOV A,R7 ; to get the next byte from the table
MOVC A,@A+DPTR ; which is the lsb of this sample, now in ACC
C_MSB_TX:
JNB TI,C_MSB_TX ; wait for transmit to complete
CLR TI ; clear for new transmit
MOV SBUF,A ; and send out the lsb of DAC C
; DAC B next
; DAC B codes should be taken from 16 bytes (8 samples) further on
; in the sine table - this gives an inverted sine function
MOV A,R7 ; pointer in R7
ADD A,#0FH ; add 15 - already done one INC
ANL A,#03FH ; wrap back round to 0 if > 64
MOV R7,A ; pointer back in R7
MOVC A,@A+DPTR ; get DAC B msb from the table
ORL A,#02H ; set control bits to DAC B address
C_LSB_TX:
JNB TI,C_LSB_TX ; wait for DAC C lsb transmit to complete
SETB T1 ; toggle FS
CLR T1
CLR TI ; clear for new transmit
MOV SBUF,A ; and send out the msb of DAC B
; get DAC B LSB
INC R7 ; increment the pointer in R7
MOV A,R7 ; to get the next byte from the table
MOVC A,@A+DPTR ; which is the lsb of this sample, now in ACC
B_MSB_TX:
JNB TI,B_MSB_TX ; wait for transmit to complete
CLR TI ; clear for new transmit
MOV SBUF,A ; and send out the lsb of DAC B
; DAC D next
; DAC D codes should be taken from 16 bytes (8 samples) further on
; in the sine table - this gives an inverted cosine function
MOV A,R7 ; pointer in R7
ADD A,#0FH ; add 15 - already done one INC
ANL A,#03FH ; wrap back round to 0 if > 64
MOV R7,A ; pointer back in R7
MOVC A,@A+DPTR ; get DAC D msb from the table
ORL A,#03H ; set control bits to DAC D address
B_LSB_TX:
JNB TI,B_LSB_TX ; wait for DAC B lsb transmit to complete
SETB T1 ; toggle FS
CLR T1
CLR TI ; clear for new transmit
MOV SBUF,A ; and send out the msb of DAC D
INC R7 ; increment the pointer in R7
MOV A,R7 ; to get the next byte from the table
MOVC A,@A+DPTR ; which is the lsb of this sample, now in ACC
D_MSB_TX:
JNB TI,D_MSB_TX ; wait for transmit to complete
CLR TI ; clear for new transmit
MOV SBUF,A ; and send out the lsb of DAC D
; increment the rolling pointer to point to the next sample
; ready for the next interrupt
MOV A,rolling_ptr
ADD A,#02H ; add 2 to the rolling pointer

```

```

ANL A,#03FH ; wrap back round to 0 if > 64
MOV rolling_ptr,A ; store in memory again
D_LSB_TX:
JNB TI,D_LSB_TX ; wait for DAC D lsb transmit to complete
CLR TI ; clear for next transmit
SETB T1 ; FS high
SETB T0 ; CS high
POP ACC
POP PSW
RETI
;-----
; Stack needs definition
;-----
RSEG STACK
DS 10h ; 16 Byte Stack!
;-----
; Main program code
;-----
RSEG MAIN
start:
MOV SP,#STACK-1 ; first set Stack Pointer
CLR A
MOV SCON,A ; set serial port 0 to mode 0
MOV TMOD,#02H ; set timer 0 to mode 2 - auto-reload
MOV TH0,#038H ; set TH0 for 5kHs interrupts
SETB INT1 ; set LDAC = 1
SETB T1 ; set FS = 1
SETB T0 ; set CS = 1
SETB ET0 ; enable timer 0 interrupts
SETB EA ; enable all interrupts
MOV rolling_ptr,A ; set rolling pointer to 0
SETB TR0 ; start timer 0
always:
SJMP always ; while(1) !
RET
;-----
; Table of 32 sine wave samples used as DAC data
;-----
RSEG SINTBL
sinevals:
DW 01000H
DW 0903EH
DW 05097H
DW 0305CH
DW 0B086H
DW 070CAH
DW 0F0E0H
DW 0F06EH
DW 0F039H
DW 0F06EH
DW 0F0E0H
DW 070CAH
DW 0B086H
DW 0305CH
DW 05097H
DW 0903EH
DW 01000H
DW 06021H
DW 0A0E8H
DW 0C063H
DW 040F9H
DW 080B5H
DW 0009FH
DW 00051H
DW 00026H
DW 00051H
DW 0009FH
DW 080B5H
DW 040F9H
DW 0C063H
DW 0A0E8H
DW 06021H

```

USING THE TLV5614IYZ WAFER CHIP-SCALE PACKAGE (WCSP)

TLV5614 qualifications are done using a wire-bonded small outline (SO) package. The qualifications include: steady state life, thermal shock, ESD, latch-up, biased HAST, autoclave, and characterization. These qualified devices are orderable as TLV5614IDW.

NOTE: The wafer chip-scale package (WCSP) for the TLV5614IYZ uses the same **die** as TLV5614IDW, but is not qualified. WCSP qualification, including board level reliability (BLR), is the responsibility of the customer.

It is recommended that underfill be used for increased reliability. BLR is application-dependent, but may include tests such as: temperature cycling, drop test, key push, bend, vibration, and package shear.

For general guidelines on board assembly of the WCSP, the following documentation provides more details:

- Application Report *NanoStar™ & NanoFree™ 300µm Solder Bump WCSP Application*—[SBVA017](#)
- Design Summary WCSP Little Logic—[SCET007B](#)

NOTE: The use of underfill is **required** and greatly reduces the risk of thermal mismatch fails.

Underfill is an epoxy/adhesive that may be added during the board assembly process to improve board level/system level reliability. The process of underfilling is to dispense the epoxy under the device after die attach reflow. The epoxy adheres to the body of the device and to the printed circuit board (PCB). It reduces stress placed upon the solder joints as a result of the thermal coefficient of expansion (TCE) mismatch between the board and the component. Underfill material typically consists of silica or other fillers to increase modulus of an epoxy, reduce creep sensitivity, and decrease the material TCE.

The recommendation for peak flow temperatures of +220°C to +230°C is based on general empirical results that indicate that this temperature range is needed to facilitate good wetting of the solder bump to the substrate or PCB. Lower peak temperatures may cause nonwets (cold solder joints).

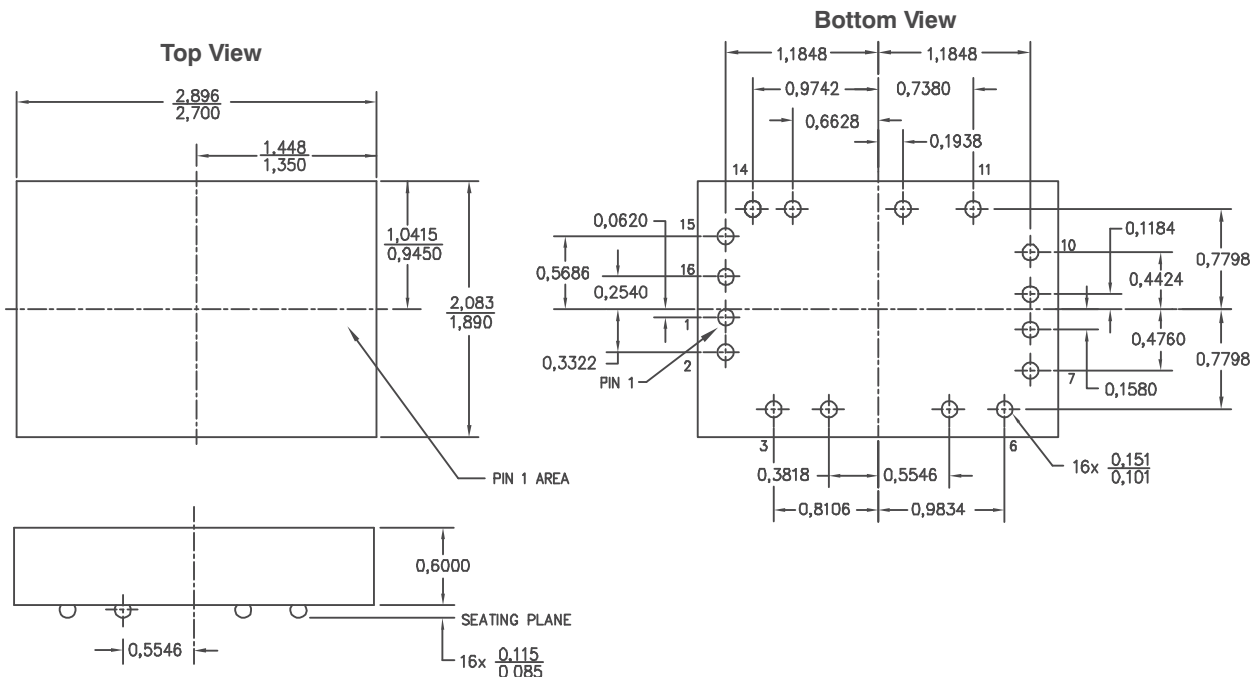

- NOTES: A. All linear dimensions are in millimeters.
 B. This drawing is subject to change without notice.

Figure 19. TLV5614IYZ Bumped Die Package

PACKAGING INFORMATION

Orderable Device	Status ⁽¹⁾	Package Type	Package Drawing	Pins	Package Qty	Eco Plan ⁽²⁾	Lead/Ball Finish	MSL Peak Temp ⁽³⁾
TLV5614IYZR	ACTIVE	DIESALE	YZ	16	3000	Green (RoHS & no Sb/Br)	SNAGCU	Level-NC-NC-UNLIM
TLV5614IYZT	ACTIVE	DIESALE	YZ	16	250	Green (RoHS & no Sb/Br)	SNAGCU	Level-NC-NC-UNLIM

⁽¹⁾ The marketing status values are defined as follows:

ACTIVE: Product device recommended for new designs.

LIFEBUY: TI has announced that the device will be discontinued, and a lifetime-buy period is in effect.

NRND: Not recommended for new designs. Device is in production to support existing customers, but TI does not recommend using this part in a new design.

PREVIEW: Device has been announced but is not in production. Samples may or may not be available.

OBsolete: TI has discontinued the production of the device.

⁽²⁾ Eco Plan - The planned eco-friendly classification: Pb-Free (RoHS), Pb-Free (RoHS Exempt), or Green (RoHS & no Sb/Br) - please check <http://www.ti.com/productcontent> for the latest availability information and additional product content details.

TBD: The Pb-Free/Green conversion plan has not been defined.

Pb-Free (RoHS): TI's terms "Lead-Free" or "Pb-Free" mean semiconductor products that are compatible with the current RoHS requirements for all 6 substances, including the requirement that lead not exceed 0.1% by weight in homogeneous materials. Where designed to be soldered at high temperatures, TI Pb-Free products are suitable for use in specified lead-free processes.

Pb-Free (RoHS Exempt): This component has a RoHS exemption for either 1) lead-based flip-chip solder bumps used between the die and package, or 2) lead-based die adhesive used between the die and leadframe. The component is otherwise considered Pb-Free (RoHS compatible) as defined above.

Green (RoHS & no Sb/Br): TI defines "Green" to mean Pb-Free (RoHS compatible), and free of Bromine (Br) and Antimony (Sb) based flame retardants (Br or Sb do not exceed 0.1% by weight in homogeneous material)

⁽³⁾ MSL, Peak Temp. -- The Moisture Sensitivity Level rating according to the JEDEC industry standard classifications, and peak solder temperature.

Important Information and Disclaimer: The information provided on this page represents TI's knowledge and belief as of the date that it is provided. TI bases its knowledge and belief on information provided by third parties, and makes no representation or warranty as to the accuracy of such information. Efforts are underway to better integrate information from third parties. TI has taken and continues to take reasonable steps to provide representative and accurate information but may not have conducted destructive testing or chemical analysis on incoming materials and chemicals. TI and TI suppliers consider certain information to be proprietary, and thus CAS numbers and other limited information may not be available for release.

In no event shall TI's liability arising out of such information exceed the total purchase price of the TI part(s) at issue in this document sold by TI to Customer on an annual basis.

TAPE AND REEL INFORMATION



QUADRANT ASSIGNMENTS FOR PIN 1 ORIENTATION IN TAPE



*All dimensions are nominal

Device	Package Type	Package Drawing	Pins	SPQ	Reel Diameter (mm)	Reel Width W1 (mm)	A0 (mm)	B0 (mm)	K0 (mm)	P1 (mm)	W (mm)	Pin1 Quadrant
TLV5614IYZR	DIESALE	YZ	16	3000	180.0	8.4	2.15	3.1	0.95	4.0	8.0	Q2
TLV5614IYZT	DIESALE	YZ	16	250	180.0	8.4	2.15	3.1	0.95	4.0	8.0	Q2

TAPE AND REEL BOX DIMENSIONS



*All dimensions are nominal

Device	Package Type	Package Drawing	Pins	SPQ	Length (mm)	Width (mm)	Height (mm)
TLV5614IYZR	DIESALE	YZ	16	3000	220.0	220.0	34.0
TLV5614IYZT	DIESALE	YZ	16	250	220.0	220.0	34.0

IMPORTANT NOTICE

Texas Instruments Incorporated and its subsidiaries (TI) reserve the right to make corrections, modifications, enhancements, improvements, and other changes to its products and services at any time and to discontinue any product or service without notice. Customers should obtain the latest relevant information before placing orders and should verify that such information is current and complete. All products are sold subject to TI's terms and conditions of sale supplied at the time of order acknowledgment.

TI warrants performance of its hardware products to the specifications applicable at the time of sale in accordance with TI's standard warranty. Testing and other quality control techniques are used to the extent TI deems necessary to support this warranty. Except where mandated by government requirements, testing of all parameters of each product is not necessarily performed.

TI assumes no liability for applications assistance or customer product design. Customers are responsible for their products and applications using TI components. To minimize the risks associated with customer products and applications, customers should provide adequate design and operating safeguards.

TI does not warrant or represent that any license, either express or implied, is granted under any TI patent right, copyright, mask work right, or other TI intellectual property right relating to any combination, machine, or process in which TI products or services are used. Information published by TI regarding third-party products or services does not constitute a license from TI to use such products or services or a warranty or endorsement thereof. Use of such information may require a license from a third party under the patents or other intellectual property of the third party, or a license from TI under the patents or other intellectual property of TI.

Reproduction of TI information in TI data books or data sheets is permissible only if reproduction is without alteration and is accompanied by all associated warranties, conditions, limitations, and notices. Reproduction of this information with alteration is an unfair and deceptive business practice. TI is not responsible or liable for such altered documentation. Information of third parties may be subject to additional restrictions.

Resale of TI products or services with statements different from or beyond the parameters stated by TI for that product or service voids all express and any implied warranties for the associated TI product or service and is an unfair and deceptive business practice. TI is not responsible or liable for any such statements.

TI products are not authorized for use in safety-critical applications (such as life support) where a failure of the TI product would reasonably be expected to cause severe personal injury or death, unless officers of the parties have executed an agreement specifically governing such use. Buyers represent that they have all necessary expertise in the safety and regulatory ramifications of their applications, and acknowledge and agree that they are solely responsible for all legal, regulatory and safety-related requirements concerning their products and any use of TI products in such safety-critical applications, notwithstanding any applications-related information or support that may be provided by TI. Further, Buyers must fully indemnify TI and its representatives against any damages arising out of the use of TI products in such safety-critical applications.

TI products are neither designed nor intended for use in military/aerospace applications or environments unless the TI products are specifically designated by TI as military-grade or "enhanced plastic." Only products designated by TI as military-grade meet military specifications. Buyers acknowledge and agree that any such use of TI products which TI has not designated as military-grade is solely at the Buyer's risk, and that they are solely responsible for compliance with all legal and regulatory requirements in connection with such use.

TI products are neither designed nor intended for use in automotive applications or environments unless the specific TI products are designated by TI as compliant with ISO/TS 16949 requirements. Buyers acknowledge and agree that, if they use any non-designated products in automotive applications, TI will not be responsible for any failure to meet such requirements.

Following are URLs where you can obtain information on other Texas Instruments products and application solutions:

Products

Amplifiers	amplifier.ti.com
Data Converters	dataconverter.ti.com
DLP® Products	www.dlp.com
DSP	dsp.ti.com
Clocks and Timers	www.ti.com/clocks
Interface	interface.ti.com
Logic	logic.ti.com
Power Mgmt	power.ti.com
Microcontrollers	microcontroller.ti.com
RFID	www.ti-rfid.com
RF/IF and ZigBee® Solutions	www.ti.com/lprf

Applications

Audio	www.ti.com/audio
Automotive	www.ti.com/automotive
Broadband	www.ti.com/broadband
Digital Control	www.ti.com/digitalcontrol
Medical	www.ti.com/medical
Military	www.ti.com/military
Optical Networking	www.ti.com/opticalnetwork
Security	www.ti.com/security
Telephony	www.ti.com/telephony
Video & Imaging	www.ti.com/video
Wireless	www.ti.com/wireless

Mailing Address: Texas Instruments, Post Office Box 655303, Dallas, Texas 75265
Copyright © 2009, Texas Instruments Incorporated

www.BDTIC.com/TI