

# TMS470R1VC336, TMS470R1VC346 16/32-BIT RISC ROM MICROCONTROLLERS

SPNS084E – MAY 2003 – REVISED AUGUST 2006

- High-Performance Static CMOS Technology
- TMS470R1x 16/32-Bit RISC Core (ARM7TDMI™)
  - 24-MHz System Clock (VC346 only)
  - 28-MHz System Clock (VC336 only)
  - 48-MHz Pipeline Mode
  - Independent 16/32-Bit Instruction Set
  - Open Architecture With Third-Party Support
  - Built-In Debug Module
  - Utilizes Big-Endian Format
- Integrated Memory
  - 128K-Byte Program ROM
    - ROM Pipeline Wrapper (RPW)
  - 8K-Byte Static RAM (SRAM)
- Operating Features
  - Core Supply Voltage ( $V_{CC}$ ): 1.81 V - 2.06 V
  - Core Supply Voltage ( $V_{CC}$ ): 1.70 V - 2.06 V  
When Used At or Below 85C Ambient Temp  
and 115C Junction Temp
  - I/O Supply Voltage ( $V_{CCIO}$ ): 3.0 V - 3.6 V
  - Low-Power Modes: STANDBY and HALT
  - Industrial and Automotive Temperature Ranges
- 470+ System Module
  - 32-Bit Address Space Decoding
  - Bus Supervision for Memory and Peripherals
  - Analog Watchdog (AWD) Timer
  - Real-Time Interrupt (RTI)
  - System Integrity and Failure Detection
- Zero-Pin Phase-Locked Loop (ZPLL)-Based Clock Module With Prescaler
  - Multiply-by-4 or -8 Internal ZPLL Option
  - ZPLL Bypass Mode
- Six Communication Interfaces:
  - Two Serial Peripheral Interfaces (SPIs)
    - 255 Programmable Baud Rates
  - Two Serial Communications Interfaces (SCIs)
    - 2<sup>24</sup> Selectable Baud Rates
    - Asynchronous/Isosynchronous Modes
  - Standard CAN Controller (SCC)
    - 16-Mailbox Capacity
    - Fully Compliant With CAN Protocol, Version 2.0B
- Class II Serial Interface (C2SIA)
  - Two Selectable Data Rates
  - Normal Mode 10.4 Kbps and 4X Mode 41.6 Kbps
- High-End Timer (HET)
  - 27 Programmable I/O Channels (VC336):
    - 23 High-Resolution Pins
    - 4 Standard-Resolution Pins
  - 16 Programmable I/O Channels (VC346):
    - 14 High-Resolution Pins
    - 2 Standard-Resolution Pins
  - High-Resolution Share Feature (XOR)
  - HET RAM (64-Instruction Capacity)
- 10-Bit Multi-Buffered ADC (MibADC) 12-Channel (VC336), 16-Channel (VC346)
  - 64-Word FIFO Buffer
  - Single- or Continuous-Conversion Modes
  - 1.55  $\mu$ s Minimum Sample and Conversion Time
  - Calibration Mode and Self-Test Features
- Eight External Interrupts (VC346)
- Six External Interrupts (VC336)
- Flexible Interrupt Handling
- 5 Dedicated General-Purpose I/O (GIO) Pins, 1 Input-Only GIO Pin, and 48 Additional Peripheral I/Os (VC336)
- 11 Dedicated GIO Pins, 1 Input-Only GIO Pin, and 38 Additional Peripheral I/Os (VC346)
- External Clock Prescale (ECP) Module
  - Programmable Low-Frequency External Clock (CLK)
- On-Chip Scan-Base Emulation Logic, IEEE Standard 1149.1<sup>†</sup> (JTAG) Test-Access Port
- 100-Pin Plastic Low-Profile Quad Flatpack (PZ Suffix)
- Development System Support Tools Available
  - Code Composer Studio™ Integrated Development Environment (IDE)
  - HET Assembler and Simulator
  - Real-Time In-Circuit Emulation



Please be aware that an important notice concerning availability, standard warranty, and use in critical applications of Texas Instruments semiconductor products and disclaimers thereto appears at the end of this data sheet.

Code Composer Studio is a trademark of Texas Instruments.  
ARM7TDMI is a trademark of Advanced RISC Machines (ARM) Limited.  
All trademarks are the property of their respective owners.

<sup>†</sup> The test-access port is compatible with the IEEE Standard 1149.1-1990, *IEEE Standard Test-Access Port and Boundary Scan Architecture* specification. Boundary scan is not supported on this device.

PRODUCTION DATA information is current as of publication date. Products conform to specifications per the Texas Instruments standard warranty. Production processing does not necessarily include testing of all parameters.

 **www.BDITC.com/TI**

POST OFFICE BOX 1443 • HOUSTON, TEXAS 77251-1443

Copyright © 2006, Texas Instruments Incorporated

# TMS470R1VC336, TMS470R1VC346 16/32-BIT RISC ROM MICROCONTROLLERS

SPNS084E – MAY 2003 – REVISED AUGUST 2006

## TMS470R1VC336 100-PIN PZ PACKAGE (TOP VIEW)

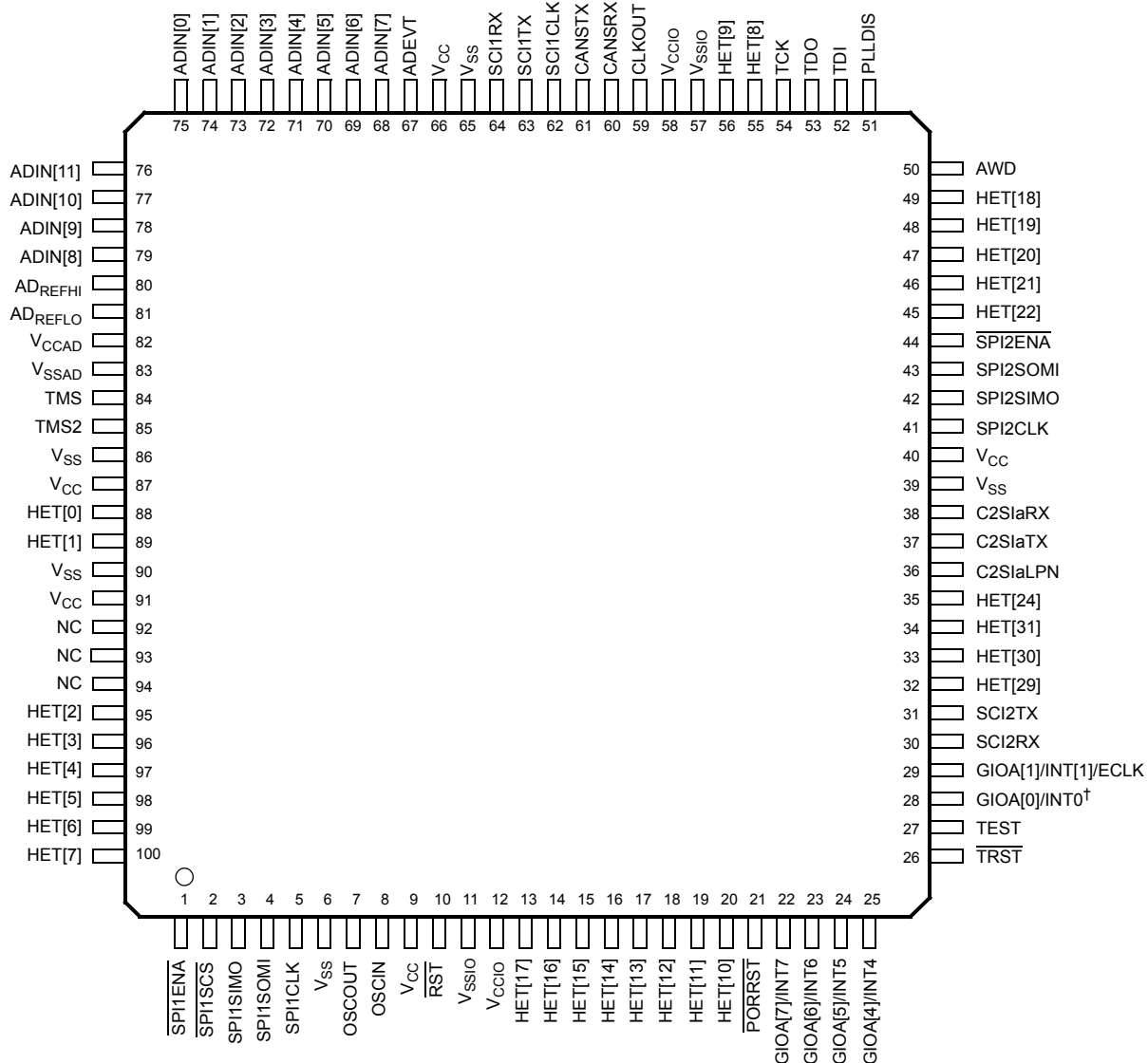

† GIOA[0]/INT0 (pin 28) is an input-only GIO pin.

# TMS470R1VC336, TMS470R1VC346 16/32-BIT RISC ROM MICROCONTROLLERS

SPNS084E – MAY 2003 – REVISED AUGUST 2006

## TMS470R1VC346 100-PIN PZ PACKAGE (TOP VIEW)

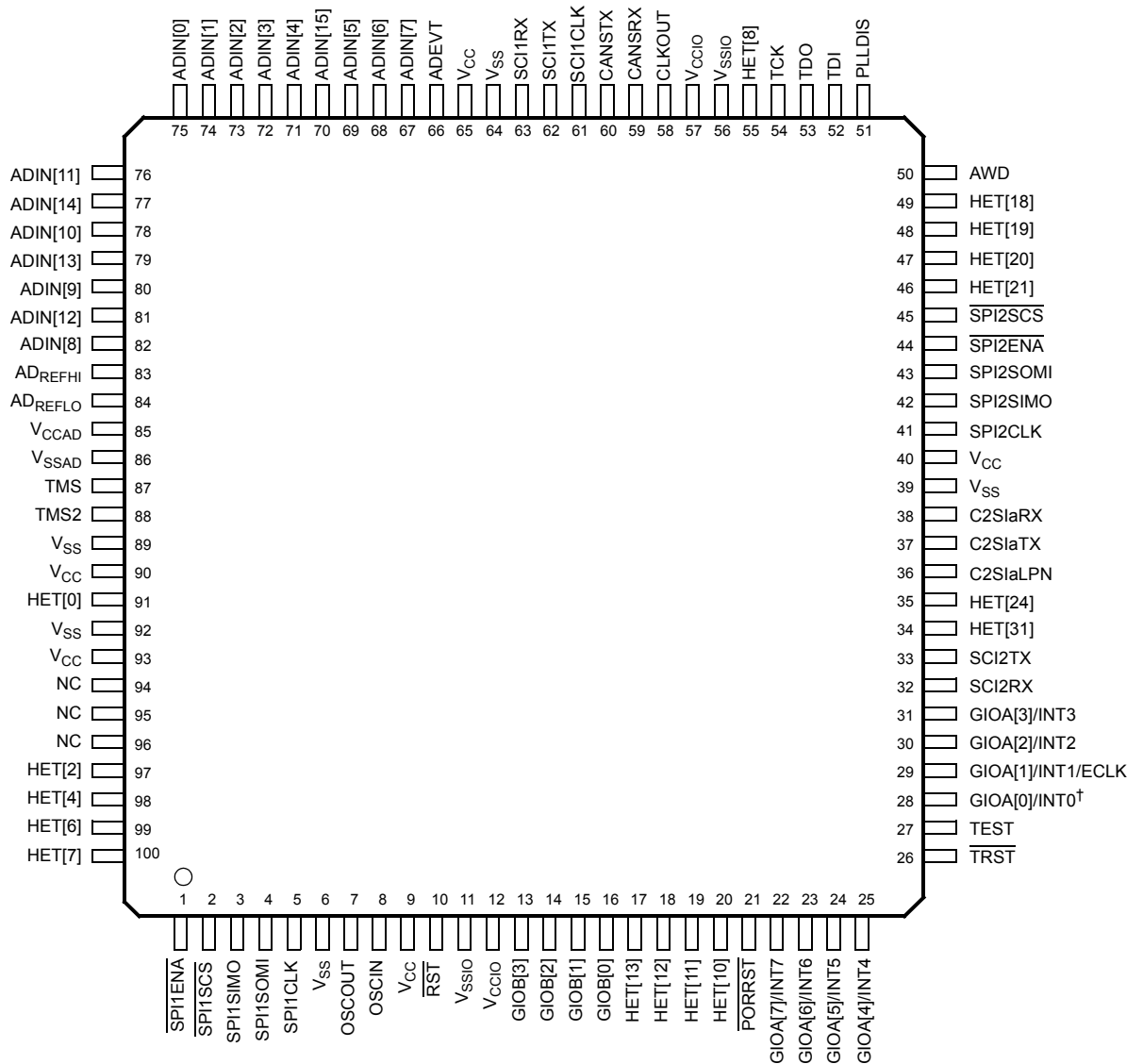

† GIOA[0]/INT0 (pin 28) is an input-only GIO pin.

# TMS470R1VC336, TMS470R1VC346 16/32-BIT RISC ROM MICROCONTROLLERS

SPNS084E – MAY 2003 – REVISED AUGUST 2006

---

## description

The TMS470R1VC336 and TMS470R1VC346<sup>†</sup> devices are members of the Texas Instruments TMS470R1x family of general-purpose 16/32-bit reduced instruction set computer (RISC) microcontrollers. These microcontrollers offer high performance utilizing the high-speed ARM7TDMI 16/32-bit RISC central processing unit (CPU), resulting in a high instruction throughput while maintaining greater code efficiency. The ARM7TDMI 16/32-bit RISC CPU views memory as a linear collection of bytes numbered upwards from zero. The TMS470R1VC3x6 utilizes the big-endian format, where the most significant byte of a word is stored at the lowest numbered byte and the least significant byte at the highest numbered byte.

High-end embedded control applications demand more performance from their controllers while maintaining low costs. The VC3x6 RISC core architecture offers solutions to these performance and cost demands while maintaining low power consumption.

The VC3x6 device contains the following:

- ARM7TDMI 16/32-Bit RISC CPU
- TMS470R1x system module (SYS) with 470+ enhancements
- 128K-byte ROM with RPW
- 8K-byte SRAM
- Zero-pin phase-locked loop (ZPLL) clock module
- Analog watchdog (AWD) timer
- Real-time interrupt (RTI) module
- Two serial peripheral interface (SPI) modules
- Two serial communications interface (SCI) modules
- Standard CAN controller (SCC)
- Class II serial interface (C2SIA)
- 10-bit multi-buffered analog-to-digital converter (MibADC), 12-input channels (VC336), 16-input channels (VC346)
- High-end timer (HET) controlling 27 I/Os (VC336), controlling 16 I/Os (VC346)
- External Clock Prescale (ECP)
- Up to 53 I/O pins and 1 input-only pin (VC336), up to 49 I/O pins and 1 input-only pin (VC346)

The functions performed by the 470+ system module (SYS) include: address decoding; memory protection; memory and peripherals bus supervision; reset and abort exception management; prioritization for all internal interrupt sources; device clock control; and parallel signature analysis (PSA). This data sheet includes device-specific information such as memory and peripheral select assignment, interrupt priority, and a device memory map. For a more detailed functional description of the SYS module, see the *TMS470R1x System Module Reference Guide* (literature number SPNU189).

The VC3x6 memory includes general-purpose SRAM supporting single-cycle read/write accesses in byte, half-word, and word modes.

The ROM memory on the VC3x6 device is programmable read-only memory that is masked at the time of device fabrication. The ROM operates with a system clock frequency of up to 24 MHz for the VC346 and up to 28 MHz for the VC336. In pipeline mode, the ROM operates with a system clock frequency of up to 48MHz. For more detailed information on the ROM Pipeline Wrapper, see the *TMS470R1x ROM Pipeline Wrapper (RPW) Reference Guide* (literature number SPNU009).

---

<sup>†</sup> Throughout the remainder of this document, the TMS470R1VC336 and TMS470R1VC346 device names, where generic, shall be referred to as TMS470R1VC3x6 or VC3x6, and where unique, shall be referred to either by the full device name, or VC336 or VC346.

## description (continued)

The VC3x6 device has six communication interfaces: two SPIs, two SCIs, an SCC, and a C2S1a. The SPI provides a convenient method of serial interaction for high-speed communications between similar shift-register type devices. The SCI is a full-duplex, serial I/O interface intended for asynchronous communication between the CPU and other peripherals using the standard Non-Return-to-Zero (NRZ) format. The SCC uses a serial, multimaster communication protocol that efficiently supports distributed real-time control with robust communication rates of up to 1 megabit per second (Mbps). The SCC is ideal for applications operating in noisy and harsh environments (e.g., automotive and industrial fields) that require reliable serial communication or multiplexed wiring. The C2S1a allows the VC3x6 to transmit and receive messages on a class II network following an SAE J1850<sup>†</sup> standard. For more detailed functional information on the SPI, SCI, and SCC peripherals, see the specific TMS470R1x Peripheral Reference Guides (literature numbers SPNU195, SPNU196, and SPNU197, respectively). For more detailed functional information on the C2S1a peripheral, see the *TMS470R1x Class II Serial Interface A (C2S1a) Reference Guide* (literature number SPNU218).

The HET is an advanced intelligent timer that provides sophisticated timing functions for real-time applications. The timer is software-controlled, using a reduced instruction set, with a specialized timer micromachine and an attached I/O port. The HET can be used for compare, capture, or general-purpose I/O. It is especially well suited for applications requiring multiple sensor information and drive actuators with complex and accurate time pulses. For more detailed functional information on the HET, see the *TMS470R1x High-End Timer (HET) Reference Guide* (literature number SPNU199). The VC3x6 HET peripheral contains the XOR-share feature. This feature allows two adjacent HET high-resolution channels to be XORed together, making it possible to output smaller pulses than a standard HET. For more detailed information on the HET XOR-share feature, see the *TMS470R1x High-End Timer (HET) Reference Guide* (literature number SPNU199).

The VC3x6 device has a 10-bit-resolution sample-and-hold MibADC. The MibADC channels can be converted individually or can be grouped by software for sequential conversion sequences. There are three separate groupings, two of which are triggerable by an external event. Each sequence can be converted once when triggered or configured for continuous conversion mode. For more detailed functional information on the MibADC, see the *TMS470R1x Multi-Buffered Analog-to-Digital Converter (MibADC) Reference Guide* (literature number SPNU206).

The zero-pin phase-locked loop (ZPLL) clock module contains a phase-locked loop, a clock-monitor circuit, a clock-enable circuit, and a prescaler (with prescale values of 1–8). The function of the ZPLL is to multiply the external frequency reference to a higher frequency for internal use. The ZPLL provides ACLK<sup>‡</sup> to the system (SYS) module. The SYS module subsequently provides system clock (SYSCLK), real-time interrupt clock (RTICLK), CPU clock (MCLK), and peripheral interface clock (ICLK) to all other VC3x6 device modules. For more detailed functional information on the ZPLL, see the *TMS470R1x Zero-Pin Phase-Locked Loop (ZPLL) Clock Module Reference Guide* (literature number SPNU212).

The VC3x6 device also has an external clock prescaler (ECP) module that when enabled, outputs a continuous external clock (ECLK) on a specified GIO pin. The ECLK frequency is a user-programmable ratio of the peripheral interface clock (ICLK) frequency. For more detailed functional information on the ECP, see the *TMS470R1x External Clock Prescaler (ECP) Reference Guide* (literature number SPNU202).

## device characteristics

The TMS470R1VC3x6 device is a derivative of the F05 system emulation device SE470R1VB8AD. Table 1 identifies all the characteristics of the TMS470R1VC3x6 device except the SYSTEM and CPU, which are generic. The COMMENTS column aids the user in software-programming and references device-specific information.

<sup>†</sup> SAE Standard J1850 Class B Data Communication Network Interface

<sup>‡</sup> ACLK should not be confused with the MibADC internal clock, ADCLK. ACLK is the continuous system clock from an external resonator/crystal reference.

# TMS470R1VC336, TMS470R1VC346 16/32-BIT RISC ROM MICROCONTROLLERS

SPNS084E – MAY 2003 – REVISED AUGUST 2006

## device characteristics (continued)

**Table 1. Device Characteristics**

| CHARACTERISTICS   | DEVICE DESCRIPTION<br>TMS470R1VC336 | DEVICE DESCRIPTION<br>TMS470R1VC346 | COMMENTS  |
|---|-------------------------------------|-------------------------------------|---|
| <b>MEMORY</b>   |                                     |                                     |   |
| For the number of memory selects on this device, see the Memory Selection Assignment tables (Table 2).  |                                     |                                     |   |
| INTERNAL MEMORY   | 128K-Byte ROM<br>8K-Byte SRAM       | 128K-Byte ROM<br>8K-Byte SRAM       | Pipeline capable.<br><br>The VC3x6 RAM is implemented in one 8K array selected by two memory-select signals (see the VC3x6 Memory Selection Assignment table, Table 2).   |
| <b>PERIPHERALS</b>  |                                     |                                     |   |
| For the device-specific interrupt priority configurations, see the Interrupt Priority table (Table 4). And for the 1K peripheral address ranges and their peripheral selects, see the VC3x6 Peripherals and System Module Base Addresses table (Table 3). |                                     |                                     |   |
| CLOCK   | ZPLL                                | ZPLL                                | Zero-pin PLL has no external loop filter pins.  |
| GENERAL-PURPOSE I/Os  | 5 I/O<br>1 Input only               | 11 I/O<br>1 Input only              | For VC336, Port A has only six (6) external pins – GIOA[2]/INT2 and GIOA[3]/INT3 are not applicable.<br>For VC346, Port A has all eight (8) external pins, and Port B has four (4).   |
| ECP   | YES                                 | YES                                 |   |
| C2S1a   | 1                                   | 1                                   |   |
| SCI   | 1 (3-pin)<br>1 (2-pin)              | 1 (3-pin)<br>1 (2-pin)              | SCI2 has no external clock pin, only transmit/receive pins (SCI2TX and SCI2RX)  |
| CAN (HECC and/or SCC)   | 1 SCC                               | 1 SCC                               | Standard CAN controller   |
| SPI (5-pin, 4-pin or 3-pin)   | 1 (5-pin)<br>1 (4-pin)              | 2 (5-pin)                           | For VC336, SPI2 has no chip select pin.   |
| HET with XOR Share  | 27 I/O                              | 16 I/O                              | All devices have both the logic and registers for a full 32-I/O HET implemented, even though not all 32 pins are available externally.<br><br>The high-resolution (HR) SHARE feature allows even HR pins to share the next higher odd HR pin structures. This HR sharing is independent of whether or not the odd pin is available externally. If an odd pin is available externally and <i>shared</i> , then the odd pin can only be used as a general-purpose I/O. For more information on HR SHARE, see the <i>TMS470R1x High-End Timer (HET) Reference Guide</i> (literature number SPNU199). |
| HET RAM   | 64-Instruction Capacity             | 64-Instruction Capacity             |   |
| MibADC  | 10-bit, 12-channel<br>64-word FIFO  | 10-bit, 16-channel<br>64-word FIFO  | 12-channel MibADC (VC336), 16-channel MibADC (VC346). Both the logic and registers for a full 16-channel MibADC are present.  |
| CORE VOLTAGE  | 1.81 - 2.06 V                       | 1.81 - 2.06 V                       | When operating at or below 85C ambient temperature and 115C junction temperature.   |
|   | 1.70 – 2.06V                        | 1.70 – 2.06V                        |   |
| I/O VOLTAGE   | 3.0 - 3.6 V                         | 3.0 - 3.6 V                         |   |
| PINS  | 100                                 | 100                                 |   |
| PACKAGE   | PZ                                  | PZ                                  |   |

# TMS470R1VC336, TMS470R1VC346 16/32-BIT RISC ROM MICROCONTROLLERS

SPNS084E – MAY 2003 – REVISED AUGUST 2006

## functional block diagram

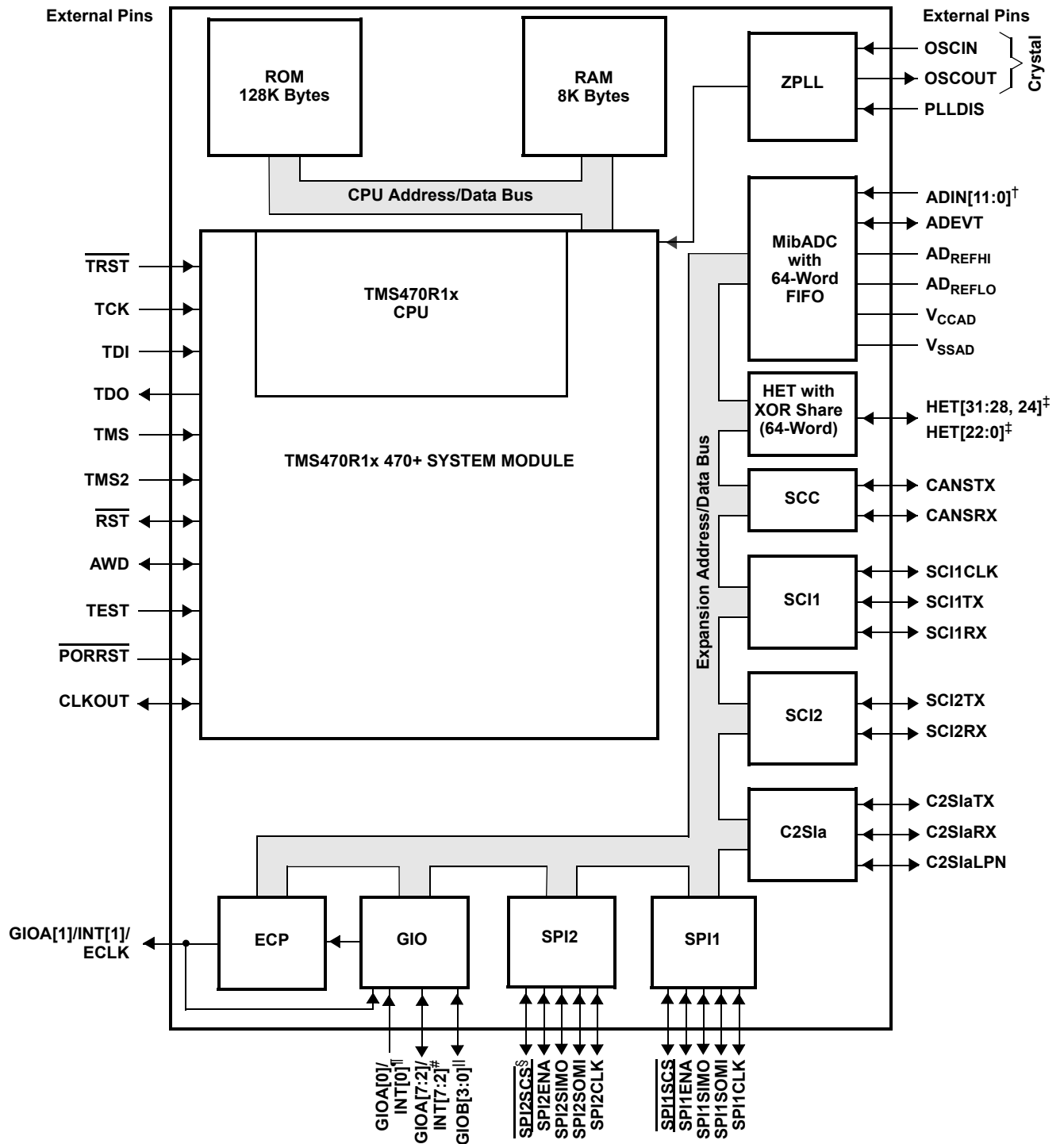

† ADIN[11:0] for VC336 and ADIN[15:0] for VC346.

‡ HET[31, 24] and HET[21:18, 13:10, 8, 7, 6, 4, 2, 0] only for VC346.

§ The SPI2 chip select pin (SPI2SCS) is only applicable to the VC346 device.

¶ GIOA[0]/INT[0] is an input-only GIO pin.

# GIOA[2]/INT[2] and GIOA[3]/INT[3] pins are not applicable to the VC336 device.

|| GIOB[3:0] are not applicable to the VC336 device.



# TMS470R1VC336, TMS470R1VC346 16/32-BIT RISC ROM MICROCONTROLLERS

SPNS084E – MAY 2003 – REVISED AUGUST 2006

## Terminal Functions

| TERMINAL                                 |       |       | TYPE†‡    | INTERNAL PULLUP/<br>PULLDOWN§ | DESCRIPTION  |           |     |                             |
|--|-------|-------|-----------|-------------------------------|--|-----------|-----|-----------------------------|
| NAME                                     | VC336 | VC346 |           |                               |  |           |     |                             |
| <b>HIGH-END TIMER (HET)</b>              |       |       |           |                               |  |           |     |                             |
| HET[0]                                   | 88    | 91    | 3.3-V I/O | IPD                           | <p>All devices have both the logic and registers for a full 32-I/O HET implemented, even though not all 32 pins are available externally.</p> <p>Timer input capture or output compare. The HET[31:0] applicable pins can be programmed as general-purpose input/output (GIO) pins.</p> <p>HET[22:0] are high-resolution pins and HET[31:28, 24] are standard-resolution pins for VC336.</p> <p>HET[21:18, 13:10, 8, 7, 6, 4, 2, 0] are high-resolution pins and HET[31, 24] are standard-resolution pins for VC346.</p> <p>The high-resolution (HR) SHARE feature allows even HR pins to share the next higher odd HR pin structures. This HR sharing is independent of whether or not the odd pin is available externally. If an odd pin is available externally and <i>shared</i>, then the odd pin can only be used as a general-purpose I/O. For more information on HR SHARE, see the <i>TMS470R1x High-End Timer Reference Guide</i> (literature number SPNU199).</p> |           |     |                             |
| HET[1]                                   | 89    | –     |           |                               |  |           |     |                             |
| HET[2]                                   | 95    | 97    |           |                               |  |           |     |                             |
| HET[3]                                   | 96    | –     |           |                               |  |           |     |                             |
| HET[4]                                   | 97    | 98    |           |                               |  |           |     |                             |
| HET[5]                                   | 98    | –     |           |                               |  |           |     |                             |
| HET[6]                                   | 99    | 99    |           |                               |  |           |     |                             |
| HET[7]                                   | 100   | 100   |           |                               |  |           |     |                             |
| HET[8]                                   | 55    | 55    |           |                               |  |           |     |                             |
| HET[9]                                   | 56    | –     |           |                               |  |           |     |                             |
| HET[10]                                  | 20    | 20    |           |                               |  |           |     |                             |
| HET[11]                                  | 19    | 19    |           |                               |  |           |     |                             |
| HET[12]                                  | 18    | 18    |           |                               |  |           |     |                             |
| HET[13]                                  | 17    | 17    |           |                               |  |           |     |                             |
| HET[14]                                  | 16    | –     |           |                               |  |           |     |                             |
| HET[15]                                  | 15    | –     |           |                               |  |           |     |                             |
| HET[16]                                  | 14    | –     |           |                               |  |           |     |                             |
| HET[17]                                  | 13    | –     |           |                               |  |           |     |                             |
| HET[18]                                  | 49    | 49    |           |                               |  |           |     |                             |
| HET[19]                                  | 48    | 48    |           |                               |  |           |     |                             |
| HET[20]                                  | 47    | 47    |           |                               |  |           |     |                             |
| HET[21]                                  | 46    | 46    |           |                               |  |           |     |                             |
| HET[22]                                  | 45    | –     |           |                               |  |           |     |                             |
| HET[24]                                  | 35    | 35    |           |                               |  |           |     |                             |
| HET[28]                                  | –¶    | –¶    |           |                               |  |           |     |                             |
| HET[29]                                  | 32    | –     |           |                               |  |           |     |                             |
| HET[30]                                  | 33    | –     |           |                               |  |           |     |                             |
| HET[31]                                  | 34    | 34    |           |                               |  |           |     |                             |
| <b>STANDARD CAN CONTROLLER (SCC)</b>     |       |       |           |                               |  |           |     |                             |
| CANSRX                                   | 60    | 59    |           |                               |  | 3.3-V I/O |     | SCC receive pin or GIO pin  |
| CANSTX                                   | 61    | 60    |           |                               |  | 3.3-V I/O | IPU | SCC transmit pin or GIO pin |
| <b>CLASS II SERIAL INTERFACE (C2SIA)</b> |       |       |           |                               |  |           |     |                             |
| C2SlaLPN                                 | 36    | 36    | 3.3-V I/O | IPD                           | C2Sla module loopback enable pin or GIO pin  |           |     |                             |
| C2SlaRX                                  | 38    | 38    | 3.3-V I/O |                               | C2Sla module receive data input pin or GIO pin   |           |     |                             |
| C2SlaTX                                  | 37    | 37    | 3.3-V I/O | IPD                           | C2Sla module transmit data output pin or GIO pin   |           |     |                             |

† I = input, O = output, PWR = power, GND = ground, REF = reference voltage, NC = no connect

‡ All I/O pins, except  $\overline{RST}$ , are configured as inputs while  $\overline{PORRST}$  is low and immediately after  $\overline{PORRST}$  goes high.

§ IPD = internal pulldown, IPU = internal pullup (all internal pullups and pulldowns are active on input pins, independent of the  $\overline{PORRST}$  state.)

¶ N/A on the VC346 device. For the VC336 device, the HET[28] signal is only connected to the pad, not to a package pin.



# TMS470R1VC336, TMS470R1VC346 16/32-BIT RISC ROM MICROCONTROLLERS

SPNS084E – MAY 2003 – REVISED AUGUST 2006

## Terminal Functions (Continued)

| TERMINAL   |       |       | TYPE†‡         | INTERNAL PULLUP/<br>PULLDOWN§ | DESCRIPTION  |
|--|-------|-------|----------------|-------------------------------|--|
| NAME   | VC336 | VC346 |                |                               |  |
| <b>GENERAL-PURPOSE I/O (GIO)</b>                           |       |       |                |                               |  |
| GIOA[0]/INT0   | 28    | 28    | 3.3-V I        | IPD                           | <p>General-purpose input/output pins.</p> <p>GIOA[0]/INT[0] is an input-only pin. GIOA[7:0]/INT[7:0] are interrupt-capable pins.</p> <p>GIOA[1]/INT[1]/ECLK pin is multiplexed with the external clock-out function of the external clock prescale (ECP) module.</p> <p>GIOA[2]/INT[2], GIOA[3]/INT[3], and GIOB[0:3] pins are not applicable on the VC336 device.</p> |
| GIOA[1]/INT1/<br>ECLK                                      | 29    | 29    | 3.3-V I/O      |                               |  |
| GIOA[2]/INT2   | –     | 30    |                |                               |  |
| GIOA[3]/INT3   | –     | 31    |                |                               |  |
| GIOA[4]/INT4   | 25    | 25    |                |                               |  |
| GIOA[5]/INT5   | 24    | 24    |                |                               |  |
| GIOA[6]/INT6   | 23    | 23    |                |                               |  |
| GIOA[7]/INT7   | 22    | 22    |                |                               |  |
| GIOB[0]  | –     | 16    |                |                               |  |
| GIOB[1]  | –     | 15    |                |                               |  |
| GIOB[2]  | –     | 14    |                |                               |  |
| GIOB[3]  | –     | 13    |                |                               |  |
| <b>MULTI-BUFFERED ANALOG-TO-DIGITAL CONVERTER (MibADC)</b> |       |       |                |                               |  |
| ADEVT  | 67    | 66    | 3.3-V I/O      | IPD                           | MibADC event input. ADEVT can be programmed as a GIO pin.  |
| ADIN[0]  | 75    | 75    | 3.3-V I        |                               | <p>MibADC analog input pins</p> <p>The VC336 device has only 12 input channels but all S/W registers are capable. ADIN[15:12] pins are not applicable to the VC336 device.</p> <p>The VC346 device has all 16 input channels.</p>  |
| ADIN[1]  | 74    | 74    |                |                               |  |
| ADIN[2]  | 73    | 73    |                |                               |  |
| ADIN[3]  | 72    | 72    |                |                               |  |
| ADIN[4]  | 71    | 71    |                |                               |  |
| ADIN[5]  | 70    | 69    |                |                               |  |
| ADIN[6]  | 69    | 68    |                |                               |  |
| ADIN[7]  | 68    | 67    |                |                               |  |
| ADIN[8]  | 79    | 82    |                |                               |  |
| ADIN[9]  | 78    | 80    |                |                               |  |
| ADIN[10]   | 77    | 78    |                |                               |  |
| ADIN[11]   | 76    | 76    |                |                               |  |
| ADIN[12]   | –     | 81    |                |                               |  |
| ADIN[13]   | –     | 79    |                |                               |  |
| ADIN[14]   | –     | 77    |                |                               |  |
| ADIN[15]   | –     | 70    |                |                               |  |
| AD <sub>REFHI</sub>  | 80    | 83    | 3.3-V<br>REF I |                               | MibADC module high-voltage reference input   |
| AD <sub>REFLO</sub>  | 81    | 84    | GND<br>REF I   |                               | MibADC module low-voltage reference input  |
| V <sub>CCAD</sub>  | 82    | 85    | 3.3-V<br>PWR   |                               | MibADC analog supply voltage   |
| V <sub>SSAD</sub>  | 83    | 86    | GND            |                               | MibADC analog ground reference   |

† I = input, O = output, PWR = power, GND = ground, REF = reference voltage, NC = no connect

‡ All I/O pins, except  $\overline{RST}$ , are configured as inputs while  $\overline{PORRST}$  is low and immediately after  $\overline{PORRST}$  goes high.

§ IPD = internal pulldown, IPU = internal pullup (all internal pullups and pulldowns are active on input pins, independent of the  $\overline{PORRST}$  state.)

¶ N/A on the VC346 device. For the VC336 device, the HET[28] signal is only connected to the pad, not to a package pin.

# TMS470R1VC336, TMS470R1VC346 16/32-BIT RISC ROM MICROCONTROLLERS

SPNS084E – MAY 2003 – REVISED AUGUST 2006

## Terminal Functions (Continued)

| TERMINAL  |       |       | TYPE†‡    | INTERNAL PULLUP/<br>PULLDOWN§ | DESCRIPTION  |
|---|-------|-------|-----------|-------------------------------|--|
| NAME  | VC336 | VC346 |           |                               |  |
| <b>SERIAL PERIPHERAL INTERFACE 1 (SPI1)</b>     |       |       |           |                               |  |
| SPI1CLK   | 5     | 5     | 3.3-V I/O | IPD                           | SPI1 clock. SPI1CLK can be programmed as a GIO pin.  |
| SPI1ENA   | 1     | 1     |           |                               | SPI1 chip enable. $\overline{\text{SPI1ENA}}$ can be programmed as a GIO pin.  |
| SPI1SCS   | 2     | 2     |           |                               | SPI1 slave chip select. $\overline{\text{SPI1SCS}}$ can be programmed as a GIO pin.  |
| SPI1SIMO  | 3     | 3     |           |                               | SPI1 data stream. Slave in/master out. SPI1SIMO can be programmed as a GIO pin.  |
| SPI1SOMI  | 4     | 4     |           |                               | SPI1 data stream. Slave out/master in. SPI1SOMI can be programmed as a GIO pin.  |
| <b>SERIAL PERIPHERAL INTERFACE 2 (SPI2)</b>     |       |       |           |                               |  |
| SPI2CLK   | 41    | 41    | 3.3-V I/O | IPD                           | SPI2 clock. SPI2CLK can be programmed as a GIO pin.  |
| SPI2ENA   | 44    | 44    |           |                               | SPI2 chip enable. $\overline{\text{SPI2ENA}}$ can be programmed as a GIO pin.  |
| SPI2SCS   | –     | 45    |           |                               | SPI2 slave chip select. $\overline{\text{SPI2SCS}}$ can be programmed as a GIO pin. (This pin is not applicable to the VC336 device.)  |
| SPI2SIMO  | 42    | 42    |           |                               | SPI2 data stream. Slave in/master out. SPI2SIMO can be programmed as a GIO pin.  |
| SPI2SOMI  | 43    | 43    |           |                               | SPI2 data stream. Slave out/master in. SPI2SOMI can be programmed as a GIO pin.  |
| <b>ZERO-PIN PHASE-LOCKED LOOP (ZPLL)</b>        |       |       |           |                               |  |
| OSCIN   | 8     | 8     | 1.8-V I   |                               | Crystal connection pin or external clock input   |
| OSCOU   | 7     | 7     | 1.8-V O   |                               | External crystal connection pin  |
| PLLDIS  | 51    | 51    | 3.3-V I   | IPD                           | Enable/disable the ZPLL. The ZPLL can be bypassed and the oscillator becomes the system clock. If not in bypass mode, TI recommends that this pin be connected to ground or pulled down to ground by an external resistor.   |
| <b>SERIAL COMMUNICATIONS INTERFACE 1 (SCI1)</b> |       |       |           |                               |  |
| SCI1CLK   | 62    | 61    | 3.3-V I/O | IPD                           | SCI1 clock. SCI1CLK can be programmed as a GIO pin.  |
| SCI1RX  | 64    | 63    | 3.3-V I/O | IPU                           | SCI1 data receive. SCI1RX can be programmed as a GIO pin.  |
| SCI1TX  | 63    | 62    | 3.3-V I/O | IPU                           | SCI1 data transmit. SCI1TX can be programmed as a GIO pin.   |
| <b>SERIAL COMMUNICATIONS INTERFACE 2 (SCI2)</b> |       |       |           |                               |  |
| SCI2RX  | 30    | 32    | 3.3-V I/O | IPU                           | SCI2 data receive. SCI2RX can be programmed as a GIO pin.  |
| SCI2TX  | 31    | 33    | 3.3-V I/O | IPU                           | SCI2 data transmit. SCI2TX can be programmed as a GIO pin.   |
| <b>SYSTEM MODULE (SYS)</b>                      |       |       |           |                               |  |
| CLKOUT  | 59    | 58    | 3.3-V I/O | IPD                           | Bidirectional pin. CLKOUT can be programmed as a GIO pin or the output of SYSCLK, ICLK, or MCLK.   |
| $\overline{\text{PORRST}}$                      | 21    | 21    | 3.3-V I   | IPD                           | Input master chip power-up reset. External $V_{CC}$ monitor circuitry must assert a power-on reset.  |
| $\overline{\text{RST}}$                         | 10    | 10    | 3.3-V I/O | IPU                           | Bidirectional reset. The internal circuitry can assert a reset, and an external system reset can assert a device reset.<br>On this pin, the output buffer is implemented as an open drain (drives low only).<br>To ensure an external reset is not arbitrarily generated, TI recommends that an external pullup resistor be connected to this pin. |

† I = input, O = output, PWR = power, GND = ground, REF = reference voltage, NC = no connect

‡ All I/O pins, except  $\overline{\text{RST}}$ , are configured as inputs while  $\overline{\text{PORRST}}$  is low and immediately after  $\overline{\text{PORRST}}$  goes high.

§ IPD = internal pulldown, IPU = internal pullup (all internal pullups and pulldowns are active on input pins, independent of the  $\overline{\text{PORRST}}$  state.)

¶ N/A on the VC346 device. For the VC336 device, the HET[28] signal is only connected to the pad, not to a package pin.

# TMS470R1VC336, TMS470R1VC346 16/32-BIT RISC ROM MICROCONTROLLERS

SPNS084E – MAY 2003 – REVISED AUGUST 2006

## Terminal Functions (Continued)

| TERMINAL                                     |       |       | TYPE†‡       | INTERNAL PULLUP/<br>PULLDOWN§ | DESCRIPTION   |
|--|-------|-------|--------------|-------------------------------|---|
| NAME   | VC336 | VC346 |              |                               |   |
| <b>WATCHDOG/REAL-TIME INTERRUPT (WD/RTI)</b> |       |       |              |                               |   |
| AWD  | 50    | 50    | 3.3-V I/O    | IPD                           | Analog watchdog reset. The AWD pin provides a system reset if the WD KEY is not written in time by the system, providing an external RC network circuit is connected. If the user is not using AWD, TI recommends that this pin be connected to ground or pulled down to ground by an external resistor.<br><br>For more details on the external RC network circuit, see the <i>TMS470R1x System Module Reference Guide</i> (literature number SPNU189) and the application note <i>Analog Watchdog Resistor, Capacitor and Discharge Interval Selection Constraints</i> (literature number SPNA005). |
| <b>TEST/DEBUG (T/D)</b>                      |       |       |              |                               |   |
| TCK  | 54    | 54    | 3.3-V I      | IPD                           | Test clock. TCK controls the test hardware (JTAG)   |
| TDI  | 52    | 52    | 3.3-V I      | IPU                           | Test data in. TDI inputs serial data to the test instruction register, test data register, and programmable test address (JTAG).  |
| TDO  | 53    | 53    | 3.3-V O      | IPD                           | Test data out. TDO outputs serial data from the test instruction register, test data register, identification register, and programmable test address (JTAG).   |
| TEST   | 27    | 27    | 3.3-V I      | IPD                           | Test enable. Reserved for internal use only. TI recommends that this pin be connected to ground or pulled down to ground by an external resistor.   |
| TMS  | 84    | 87    | 3.3-V I      | IPU                           | Serial input for controlling the state of the CPU test access port (TAP) controller (JTAG)  |
| TMS2   | 85    | 88    | 3.3-V I      | IPU                           | Serial input for controlling the second TAP. TI recommends that this pin be connected to V <sub>CCIO</sub> or pulled up to V <sub>CCIO</sub> by an external resistor.   |
| $\overline{\text{TRST}}$                     | 26    | 26    | 3.3-V I      | IPD                           | Test hardware reset to TAP1 and TAP2. IEEE Standard 1149-1 (JTAG) Boundary-Scan Logic. TI recommends that this pin be pulled down to ground by an external resistor.  |
| <b>SUPPLY VOLTAGE CORE (1.8 V)</b>           |       |       |              |                               |   |
| V <sub>CC</sub>                              | 9     | 9     | 1.8-V<br>PWR |                               | Core logic supply voltage   |
|  | 40    | 40    |              |                               |   |
|  | 66    | 65    |              |                               |   |
|  | 87    | 90    |              |                               |   |
|  | 91    | 93    |              |                               |   |
| <b>SUPPLY VOLTAGE DIGITAL I/O (3.3 V)</b>    |       |       |              |                               |   |
| V <sub>CCIO</sub>                            | 12    | 12    | 3.3-V<br>PWR |                               | Digital I/O supply voltage  |
|  | 58    | 57    |              |                               |   |
| <b>SUPPLY GROUND CORE</b>                    |       |       |              |                               |   |
| V <sub>SS</sub>                              | 6     | 6     | GND          |                               | Core supply ground reference  |
|  | 39    | 39    |              |                               |   |
|  | 65    | 64    |              |                               |   |
|  | 86    | 89    |              |                               |   |
|  | 90    | 92    |              |                               |   |
| <b>SUPPLY GROUND DIGITAL I/O</b>             |       |       |              |                               |   |
| V <sub>SSIO</sub>                            | 11    | 11    | GND          |                               | Digital I/O supply ground reference   |
|  | 57    | 56    |              |                               |   |

† I = input, O = output, PWR = power, GND = ground, REF = reference voltage, NC = no connect

‡ All I/O pins, except RST, are configured as inputs while PORRST is low and immediately after PORRST goes high.

§ IPD = internal pulldown, IPU = internal pullup (all internal pullups and pulldowns are active on input pins, independent of the  $\overline{\text{PORRST}}$  state.)

¶ N/A on the VC346 device. For the VC336 device, the HET[28] signal is only connected to the pad, not to a package pin.

# TMS470R1VC336, TMS470R1VC346 16/32-BIT RISC ROM MICROCONTROLLERS

SPNS084E – MAY 2003 – REVISED AUGUST 2006

## VC3X6 DEVICE-SPECIFIC INFORMATION

### memory

Figure 1 shows the memory map of the VC3x6 device.

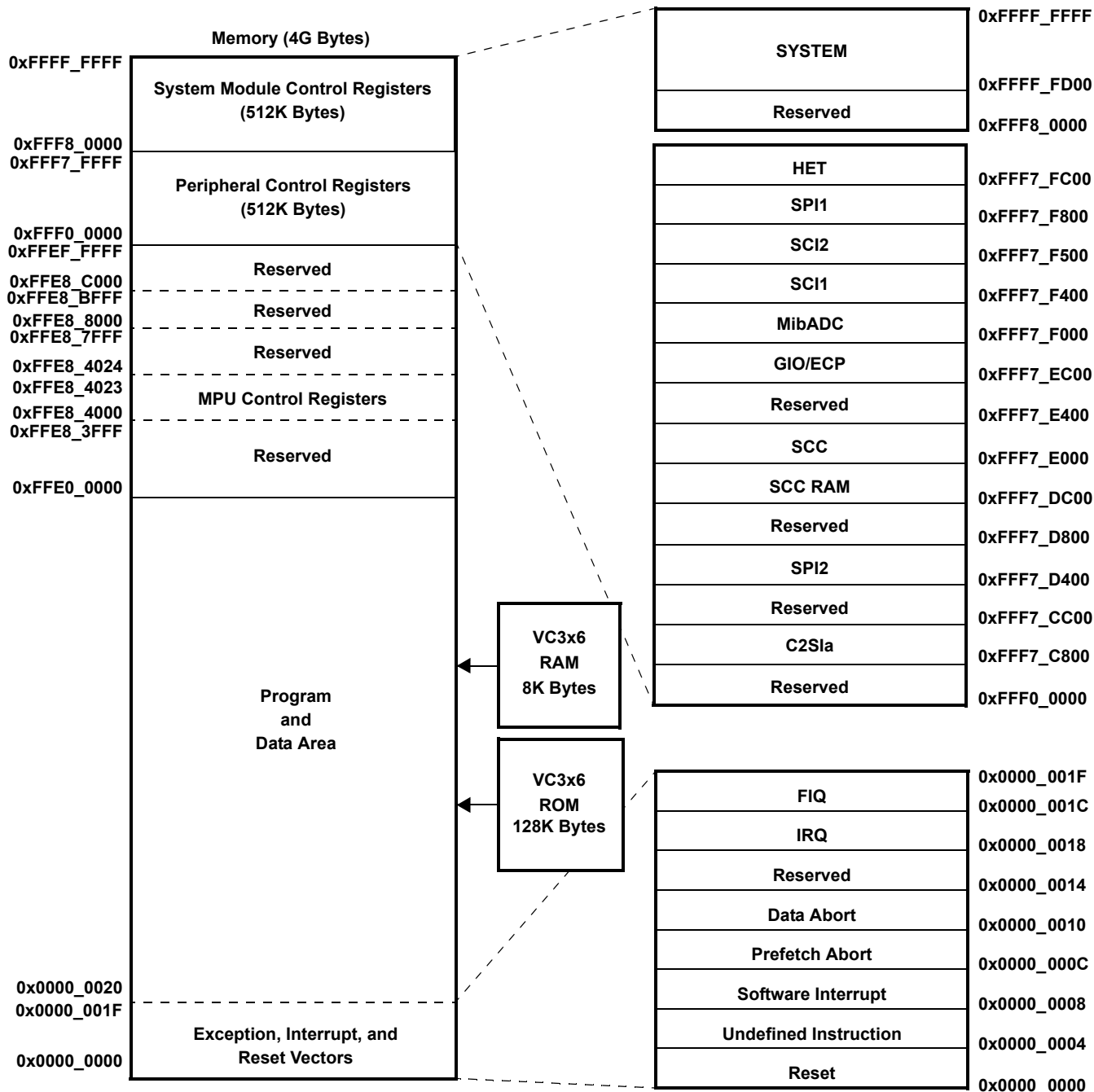

NOTES: A. Memory addresses are configurable by the system (SYS) module within the range of 0x0000\_0000 to 0xFFE0\_0000.  
B. The CPU registers are not a part of the memory map.

Figure 1. Memory Map

## memory selects

Memory selects allow the user to address memory arrays (i.e., ROM, RAM, and HET RAM) at user-defined addresses. Each memory select has its own set (low and high) of memory base address registers (MFBAHRx and MFBALRx) that, together, define the array's starting (base) address, size, and protection.

The base address of each memory select is configurable to any memory address boundary that is a multiple of the decoded block size. The decoded block size for the ROM memory on this device is 0x00100000. For more information on how to control and configure these memory select registers, see the bus structure and memory sections of the *TMS470R1x System Module Reference Guide* (literature number SPNU189).

For the memory selection assignments and the memory selected, see Table 2.

**Table 2. VC3x6 Memory Selection Assignment**

| MEMORY SELECT | MEMORY SELECTED (ALL INTERNAL) | MEMORY SIZE     | MPU | MEMORY BASE ADDRESS REGISTER | STATIC MEM CTL REGISTER |
|---------------|--------------------------------|-----------------|-----|------------------------------|-------------------------|
| 0 (fine)      | ROM                            | 128K            | NO  | MFBAHR0 and MFBALR0          |                         |
| 1 (fine)      | ROM                            |                 | NO  | MFBAHR1 and MFBALR1          |                         |
| 2 (fine)      | RAM                            | 8K <sup>†</sup> | YES | MFBAHR2 and MFBALR2          |                         |
| 3 (fine)      | RAM                            |                 | YES | MFBAHR3 and MFBALR3          |                         |
| 4 (fine)      | HET RAM                        | 1K              |     | MFBAHR4 and MFBALR4          | SMCR1                   |

<sup>†</sup> The starting addresses for both RAM memory-select signals *cannot* be offset from each other by a multiple of the user-defined block size in the memory-base address register.

## RAM

The VC3x6 device contains 8K bytes of internal static RAM configurable by the SYS module to be addressed within the range of 0x0000\_0000 to 0xFFE0\_0000. This VC3x6 RAM is implemented in one 8K array selected by two memory-select signals. These configurations impose an additional constraint on the memory map for RAM; the starting addresses for both RAM memory selects *cannot* be offset from each other by the multiples of the size of the physical RAM (i.e., 8K for the VC3x6 device). The VC3x6 RAM is addressed through memory selects 2 and 3.

The RAM can be protected by the memory protection unit (MPU) portion of the SYS module, allowing the user finer blocks of memory protection than is allowed by the memory selects. The MPU is ideal for protecting an operating system while allowing access to the current task. For more detailed information on the MPU portion of the SYS module and memory protection, see the memory section of the *TMS470R1x System Module Reference Guide* (literature number SPNU189).

## ROM

The VC3x6 program ROM consists of 128K bytes mask programmable read-only memory. The program ROM is used for permanent storage of data or instructions. Programming the mask ROM is performed at the time of device fabrication.

## HET RAM

The VC3x6 device contains HET RAM. The HET RAM has a 64-instruction capability. The HET RAM is configurable by the SYS module to be addressed within the range of 0x0000\_0000 to 0xFFE0\_0000. The HET RAM is addressed through memory select 4.

# TMS470R1VC336, TMS470R1VC346 16/32-BIT RISC ROM MICROCONTROLLERS

SPNS084E – MAY 2003 – REVISED AUGUST 2006

## peripheral selects and base addresses

The VC3x6 device uses ten of the sixteen peripheral selects to decode the base addresses of the peripherals. These peripheral selects are fixed and transparent to the user since they are part of the decoding scheme used by the SYS module.

Control registers for the peripherals and SYS module begin at the base addresses shown in Table 3.

**Table 3. VC3x6 Peripherals and System Module Base Addresses**

| CONNECTING MODULE     | ADDRESS RANGE |                | PERIPHERAL SELECTS |
|-----------------------|---------------|----------------|--------------------|
|                       | BASE ADDRESS  | ENDING ADDRESS |                    |
| SYSTEM                | 0xFFFF_FD00   | 0xFFFF_FFFF    | N/A                |
| RESERVED              | 0xFFF8_0000   | 0xFFFF_FCFF    | N/A                |
| HET                   | 0xFFF7_FC00   | 0xFFF7_FFFF    | PS[0]              |
| SPI1                  | 0xFFF7_F800   | 0xFFF7_FBFF    | PS[1]              |
| SCI2                  | 0xFFF7_F500   | 0xFFF7_F7FF    | PS[2]              |
| SCI1                  | 0xFFF7_F400   | 0xFFF7_F4FF    |                    |
| ADC                   | 0xFFF7_F000   | 0xFFF7_F3FF    | PS[3]              |
| GIO/ECP               | 0xFFF7_EC00   | 0xFFF7_EFFF    | PS[4]              |
| RESERVED              | 0xFFF7_E400   | 0xFFF7_EBFF    | PS[5] - PS[6]      |
| SCC                   | 0xFFF7_E000   | 0xFFF7_E3FF    | PS[7]              |
| SCC RAM               | 0xFFF7_DC00   | 0xFFF7_DFFF    | PS[8]              |
| RESERVED              | 0xFFF7_D800   | 0xFFF7_DBFF    | PS[9]              |
| SPI2                  | 0xFFF7_D400   | 0xFFF7_D7FF    | PS[10]             |
| RESERVED              | 0xFFF7_CC00   | 0xFFF7_D3FF    | PS[11] - PS[12]    |
| C2SIA                 | 0xFFF7_C800   | 0xFFF7_CBFF    | PS[13]             |
| RESERVED              | 0xFFF7_C000   | 0xFFF7_C7FF    | PS[14] - PS[15]    |
| RESERVED              | 0xFFF0_0000   | 0xFFF7_BFFF    | N/A                |
| ROM CONTROL REGISTERS | 0xFFE8_8000   | 0xFFE8_BFFF    | N/A                |
| MPU CONTROL REGISTERS | 0xFFE8_4000   | 0xFFE8_4023    | N/A                |

## interrupt priority

The central interrupt manager (CIM) portion of the SYS module manages the interrupt requests from the device modules (i.e., SPI1 or SPI2, SCI1 or SCI2, and RTI, etc.).

Although the CIM can accept up to 32 interrupt request signals, the VC3x6 device only uses 21 of those interrupt request signals. The request channels are maskable so that individual channels can be selectively disabled. All interrupt requests can be programmed in the CIM to be of either type:

- Fast interrupt request (FIQ)
- Normal interrupt request (IRQ)

The precedences of request channels decrease with ascending channel order in the CIM (0 [highest] and 31 [lowest] priority). For these channel priorities and the associated modules, see Table 4.

**Table 4. Interrupt Priority**

| MODULES   | INTERRUPT SOURCES         | INTERRUPT LEVEL/CHANNEL |
|-----------|---------------------------|-------------------------|
| SPI1      | SPI1 end-transfer/overrun | 0                       |
| RTI       | COMP2 interrupt           | 1                       |
| RTI       | COMP1 interrupt           | 2                       |
| RTI       | TAP interrupt             | 3                       |
| SPI2      | SPI2 end-transfer/overrun | 4                       |
| GIO       | Interrupt A               | 5                       |
| RESERVED  |                           | 6                       |
| HET       | Interrupt A               | 7                       |
| RESERVED  |                           | 8                       |
| SCI1/SCI2 | SCI1/SCI2 error interrupt | 9                       |
| SCI1      | SCI1 receive interrupt    | 10                      |
| C2Sla     | C2Sla interrupt           | 11                      |
| RESERVED  |                           | 12                      |
| RESERVED  |                           | 13                      |
| SCC       | Interrupt A               | 14                      |
| RESERVED  |                           | 15                      |
| MibADC    | End event conversion      | 16                      |
| SCI2      | SCI2 receive interrupt    | 17                      |
| RESERVED  |                           | 18                      |
| RESERVED  |                           | 19                      |
| SCI1      | SCI1 transmit interrupt   | 20                      |
| System    | SW interrupt (SSI)        | 21                      |
| RESERVED  |                           | 22                      |
| HET       | Interrupt B               | 23                      |
| RESERVED  |                           | 24                      |
| SCC       | Interrupt B               | 25                      |
| SCI2      | SCI2 transmit interrupt   | 26                      |
| MibADC    | End Group 1 conversion    | 27                      |
| RESERVED  |                           | 28                      |
| GIO       | Interrupt B               | 29                      |
| MibADC    | End Group 2 conversion    | 30                      |
| RESERVED  |                           | 31                      |



# TMS470R1VC336, TMS470R1VC346 16/32-BIT RISC ROM MICROCONTROLLERS

SPNS084E – MAY 2003 – REVISED AUGUST 2006

## MibADC

The multi-buffered analog-to-digital converter (MibADC) accepts an analog signal and converts the signal to a 10-bit digital value.

The VC3x6 MibADC module can function in two modes: compatibility mode, where its programmer's model is compatible with the TMS470R1x ADC module and its digital results are stored in digital result registers; or in buffered mode, where the digital result registers are replaced with three FIFO buffers, one for each conversion group [event, group1 (G1), and group2 (G2)]. In buffered mode, the MibADC buffers can be serviced by interrupts or by the DMA.

### MibADC event trigger enhancements

The MibADC includes two major enhancements over the event-triggering capability of the TMS470R1x ADC.

- Both group1 and the event group can be configured for event-triggered operation, providing up to two event-triggered groups.
- The trigger source and polarity can be selected individually for both group 1 and the event group from the three options identified in Table 5.

**Table 5. MibADC Event Hookup Configuration**

| EVENT # | SOURCE SELECT BITS FOR G1 OR EVENT<br>(G1SRC[1:0] or EVSRC[1:0]) | SIGNAL PIN NAME |
|---------|--|-----------------|
| EVENT1  | 00   | ADEVT           |
| EVENT2  | 01   | HET18           |
| EVENT3  | 10   | HET19           |
| EVENT4  | 11   | RESERVED        |

For group 1, these event-triggered selections are configured via the group 1 source select bits (G1SRC[1:0]) in the AD event source register (ADEVTSRC.[5:4]). For the event group, these event-triggered selections are configured via the event group source select bits (EVSRC[1:0]) in the AD event source register (ADEVTSRC.[1:0]).

For more detailed functional information on the MibADC, see the *TMS470R1x Multi-Buffered Analog-to-Digital Converter (MibADC) Reference Guide* (literature number SPNU206).

## development system support

Texas Instruments provides extensive hardware and software development support tools for the TMS470R1x family. These support tools include:

- Code Composer Studio™ Integrated Development Environment (IDE)
  - Fully integrated suite of software development tools
  - Includes Compiler/Assembler/Linker, Debugger, and Simulator
  - Supports Real-Time analysis, data visualization, and open API
- Optimizing C compiler
  - Supports high-level language programming
  - Full implementation of the standard ANSI C language
  - Powerful optimizer that improves code-execution speed and reduces code size
  - Extensive run-time support library included
  - TMS470R1x control registers easily accessible from the C program
  - Interfaces C functions and assembly functions easily
  - Establishes comprehensive, easy-to-use tool set for the development of high-performance microcontroller applications in C/C++
- Assembly language tools (assembler and linker)
  - Provides extensive macro capability
  - Allows high-speed operation
  - Allows extensive control of the assembly process using assembler directives
  - Automatically resolves memory references as C and assembly modules are combined
- TMS470R1x CPU Simulator
  - Provides capability to simulate CPU operation without emulation hardware
  - Allows inspection and modifications of memory locations
  - Allows debugging programs in C or assembly language
- XDS emulation communication kits
  - Allow high-speed JTAG communication to the TMS470R1x emulator or target board

For information on pricing and availability, contact the nearest TI field sales office or authorized distributor.

Code Composer Studio is a trademark of Texas Instruments.

# TMS470R1VC336, TMS470R1VC346 16/32-BIT RISC ROM MICROCONTROLLERS

SPNS084E – MAY 2003 – REVISED AUGUST 2006

---

## documentation support

Extensive documentation supports all of the TMS470 microcontroller family generation of devices. The types of documentation available include: data sheets with design specifications; complete user's guides for all devices and development support tools; and hardware and software applications. Useful reference documentation includes:

- User's Guides
  - *TMS470R1x 32-Bit RISC Microcontroller Family User's Guide* (literature number SPNU134)
  - *TMS470R1x C/C++ Compiler User's Guide* (literature number SPNU151)
  - *TMS470R1x Code Generation Tools Getting Started Guide* (literature number SPNU117)
  - *TMS470R1x C Source Debugger User's Guide* (literature number SPNU124)
  - *TMS470R1x Assembly Language Tools User's Guide* (literature number SPNU118)
  - *TMS470R1x System Module Reference Guide* (literature number SPNU189)
  - *TMS470R1x Serial Peripheral Interface (SPI) Reference Guide* (literature number SPNU195)
  - *TMS470R1x Serial Communication Interface (SCI) Reference Guide* (literature number SPNU196)
  - *TMS470R1x Controller Area Network (CAN) Reference Guide* (literature number SPNU197)
  - *TMS470R1x High-End Timer (HET) Reference Guide* (literature number SPNU199)
  - *TMS470R1x External Clock Prescale (ECP) Reference Guide* (literature number SPNU202)
  - *TMS470R1x Multi-Buffered Analog-to-Digital Converter (MibADC) Reference Guide* (literature number SPNU206)
  - *TMS470R1x Zero-Pin Phase-Locked Loop (ZPLL) Clock Module Reference Guide* (literature number SPNU212)
  - *TMS470R1x F05 Flash Reference Guide* (literature number SPNU213)
  - *TMS470R1x Class II Serial Interface A (C2S1a) Reference Guide* (literature number SPNU218)
- Application Reports:
  - *Analog Watchdog Resistor, Capacitor and Discharge Interval Selection Constraints* (literature number SPNA005)
  - *F05/C05 Power Up Reset and Power Sequencing Requirements* (literature number SPNA009)

## device numbering conventions

Figure 2 illustrates the numbering and symbol nomenclature for the TMS470R1x family.

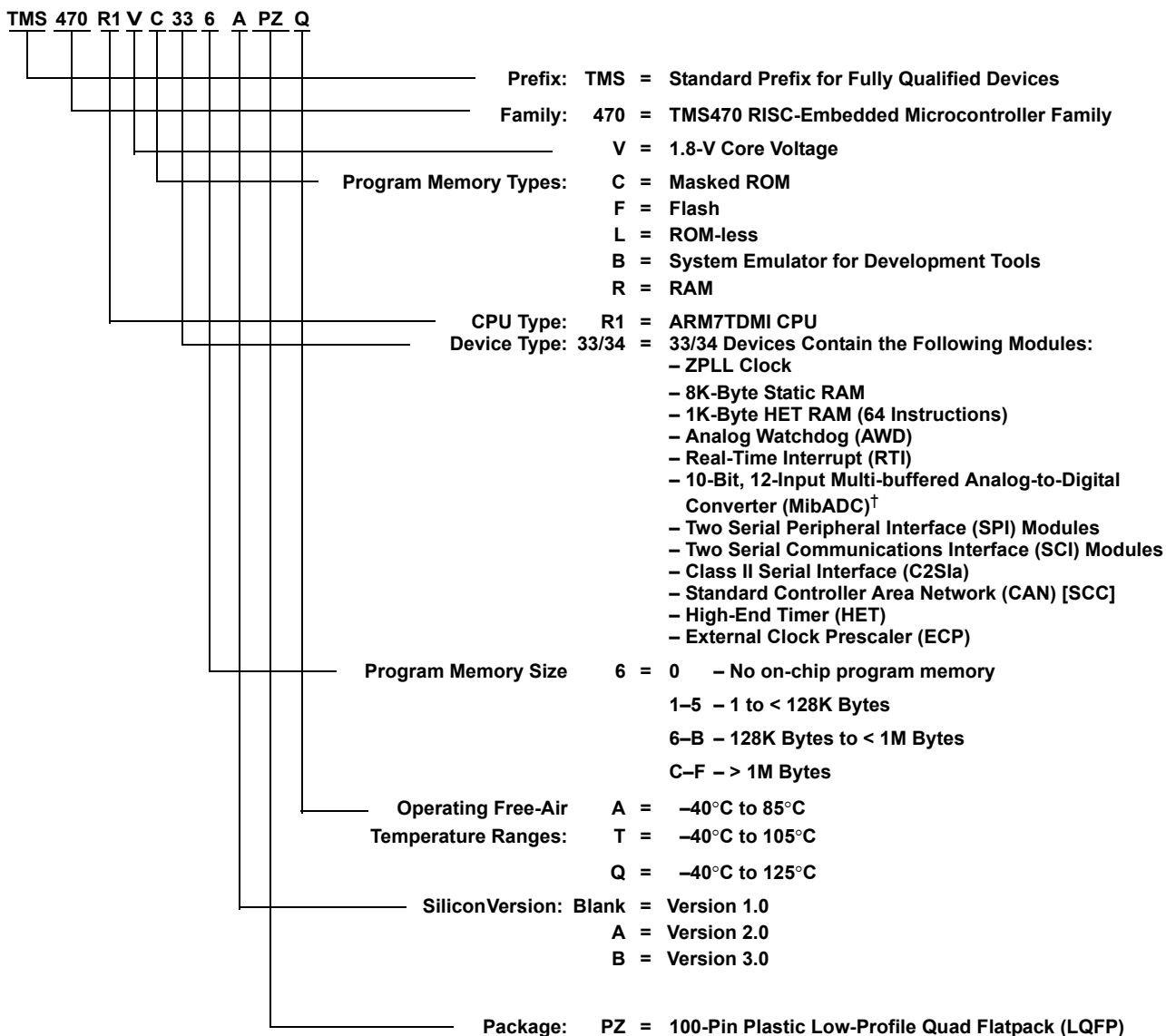

<sup>†</sup> The VC346 device contains a 10-bit, 16-input MibADC.

**Figure 2. TMS470R1x Family Nomenclature**

# TMS470R1VC336, TMS470R1VC346 16/32-BIT RISC ROM MICROCONTROLLERS

SPNS084E – MAY 2003 – REVISED AUGUST 2006

## device identification code register

The device identification code register identifies the silicon version, the technology family (TF), a ROM or Flash device, and an assigned device-specific part number (see Table 6). The VC3x6 device identification code register value is 0xnC5F.

Table 6. TMS470 Device ID Bit Allocation Register

|           |    |    |    |     |     |             |    |    |    |    |    |     |     |     |        |
|-----------|----|----|----|-----|-----|-------------|----|----|----|----|----|-----|-----|-----|--------|
| BIT 31    | 30 | 29 | 28 | 27  | 26  | 25          | 24 | 23 | 22 | 21 | 20 | 19  | 18  | 17  | BIT 16 |
| RESERVED  |    |    |    |     |     |             |    |    |    |    |    |     |     |     |        |
| FFFF_FFF0 |    |    |    |     |     |             |    |    |    |    |    |     |     |     |        |
| BIT 15    | 14 | 13 | 12 | 11  | 10  | 9           | 8  | 7  | 6  | 5  | 4  | 3   | 2   | 1   | BIT 0  |
| VERSION   |    |    |    | TF  | R/F | PART NUMBER |    |    |    |    |    | 1   | 1   | 1   |        |
| R-K       |    |    |    | R-K | R-K | R-K         |    |    |    |    |    | R-1 | R-1 | R-1 |        |

### LEGEND:

For bits 3–15: R = Read only, -K = Value constant after RESET

For bits 0–2: R = Read only, -1 = Value after RESET

- Bits 31:16**      **Reserved.** Reads are undefined and writes have no effect.
- Bits 15:12**      **VERSION.** Silicon version (revision) bits  
These bits identify the silicon version of the device.
- Bit 11**          **TF.** Technology Family (TF) bit  
This bit distinguishes the technology family core power supply:  
0 = 3.3 V for F10/C10 devices  
1 = 1.8 V for F05/C05 devices
- Bit 10**          **R/F.** ROM/Flash bit  
This bit distinguishes between ROM and Flash devices:  
0 = Flash device  
1 = ROM device
- Bits 9:3**        **PART NUMBER.** Device-specific part number bits  
These bits identify the assigned device-specific part number.  
The assigned device-specific part number for the VC3x6 device is: 0001011.
- Bits 2:0**        **"1" Mandatory High.** Bits 2, 1, and 0 are tied high by default.

# TMS470R1VC336, TMS470R1VC346 16/32-BIT RISC ROM MICROCONTROLLERS

SPNS084E – MAY 2003 – REVISED AUGUST 2006

## device part numbers

Table 7 lists all the available TMS470R1VC3x6 devices.

Table 7. Device Part Number†

| DEVICE PART NUMBER | PROGRAM MEMORY |              | PACKAGE TYPE | TEMPERATURE RANGES |                |                |
|--------------------|----------------|--------------|--------------|--------------------|----------------|----------------|
|                    | ROM            | FLASH EEPROM | 100-PIN LQFP | -40°C TO 85°C      | -40°C TO 105°C | -40°C TO 125°C |
| TMS470R1VC336APZA  | X              |              | X            | X                  |                |                |
| TMS470R1VC336APZ-T | X              |              | X            |                    | X              |                |
| TMS470R1VC336APZQ  | X              |              | X            |                    |                | X              |
| TMS470R1VC346APZA  | X              |              | X            | X                  |                |                |
| TMS470R1VC346APZ-T | X              |              | X            |                    | X              |                |
| TMS470R1VC346APZQ  | X              |              | X            |                    |                | X              |
| TMS470R1VC336BPZA  | X              |              | X            | X                  |                |                |
| TMS470R1VC336BPZ-T | X              |              | X            |                    | X              |                |
| TMS470R1VC336BPZQ  | X              |              | X            |                    |                | X              |
| TMS470R1VC346BPZA  | X              |              | X            | X                  |                |                |
| TMS470R1VC346BPZ-T | X              |              | X            |                    | X              |                |
| TMS470R1VC346BPZQ  | X              |              | X            |                    |                | X              |

† The various part numbers listed in this table differ due to differences in either electrical specifications or functional errata. Electrical differences will be noted in this datasheet. For functional errata, see the errata document for the specific part number you are using.

# TMS470R1VC336, TMS470R1VC346 16/32-BIT RISC ROM MICROCONTROLLERS

SPNS084E – MAY 2003 – REVISED AUGUST 2006

## DEVICE ELECTRICAL SPECIFICATIONS AND TIMING PARAMETERS

### absolute maximum ratings over operating free-air temperature range, Q version (unless otherwise noted)<sup>†</sup>

|  |                 |
|--|-----------------|
| Supply voltage ranges: $V_{CC}$ (see Note 1)                                       | –0.5 V to 2.5 V |
| Supply voltage ranges: $V_{CCIO}$ , $V_{CCAD}$ (see Note 1)                        | –0.5 V to 4.1 V |
| Input voltage range: All input pins  | –0.5 V to 4.1 V |
| Input clamp current: $I_{IK}$ ( $V_I < 0$ or $V_I > V_{CCIO}$ )                    |                 |
| All pins except ADIN[0:11], $\overline{PORRST}$ , $\overline{TRST}$ , TEST and TCK | ±20 mA          |
| $I_{IK}$ ( $V_I < 0$ or $V_I > V_{CCAD}$ )   |                 |
| ADIN[0:11]   | ±10 mA          |
| Operating free-air temperature ranges, $T_A$ : A version                           | –40°C to 85°C   |
| T version  | –40°C to 105°C  |
| Q version  | –40°C to 125°C  |
| Operating junction temperature range, $T_J$ : A version                            | –40°C to 115°C  |
| T version  | –40°C to 130°C  |
| Q version  | –40°C to 150°C  |
| Storage temperature range, $T_{stg}$   | –65°C to 150°C  |

<sup>†</sup> Stresses beyond those listed under “absolute maximum ratings” may cause permanent damage to the device. These are stress ratings only, and functional operation of the device at these or any other conditions beyond those indicated under “recommended operating conditions” is not implied. Exposure to absolute-maximum-rated conditions for extended periods may affect device reliability.

NOTE 1: All voltage values are with respect to their associated grounds.

### device recommended operating conditions<sup>‡</sup>

|            |                                     | MIN  | NOM  | MAX  | UNIT |
|------------|-------------------------------------|--|------|------|------|
| $V_{CC}$   | Digital logic supply voltage (Core) | – 40C to 125C  | 1.81 | 2.06 | V    |
|            |                                     | When operating at or below 85C ambient temp and 115C junction temp | 1.70 | 2.06 | V    |
| $V_{CCIO}$ | Digital logic supply voltage (I/O)  | 3  | 3.3  | 3.6  | V    |
| $V_{CCAD}$ | ADC supply voltage                  | 3  | 3.3  | 3.6  | V    |
| $V_{SS}$   | Digital logic supply ground         |  | 0    |      | V    |
| $V_{SSAD}$ | ADC supply ground                   | – 0.1  |      | 0.1  | V    |
| $T_A$      | Operating free-air temperature      | A version  | – 40 | 85   | °C   |
|            |                                     | T version  | – 40 | 105  |      |
|            |                                     | Q version  | – 40 | 125  |      |
| $T_J$      | Operating junction temperature      | A version  | – 40 | 115  | °C   |
|            |                                     | T version  | – 40 | 130  |      |
|            |                                     | Q version  | – 40 | 150  |      |

<sup>‡</sup> All voltages are with respect to  $V_{SS}$ , except  $V_{CCAD}$ , which is with respect to  $V_{SSAD}$ .



# TMS470R1VC336, TMS470R1VC346 16/32-BIT RISC ROM MICROCONTROLLERS

SPNS084E – MAY 2003 – REVISED AUGUST 2006

**electrical characteristics over recommended operating free-air temperature range, Q version  
(unless otherwise noted)†**

| PARAMETER  |                                 | TEST CONDITIONS   | MIN                             | MAX              | UNIT     |         |
|------------|---------------------------------|---|---------------------------------|------------------|----------|---------|
| $V_{hys}$  | Input hysteresis                |   | 0.15                            |                  | V        |         |
| $V_{IL}$   | Low-level input voltage         | All inputs‡ except OSCIN                                      | -0.3                            | 0.8              | V        |         |
|            |                                 | OSCIN only  | -0.3                            | $0.35 V_{CC}$    |          |         |
| $V_{IH}$   | High-level input voltage        | All inputs except OSCIN                                       | 2                               | $V_{CCIO} + 0.3$ | V        |         |
|            |                                 | OSCIN only  | $0.65 V_{CC}$                   | $V_{CC} + 0.3$   |          |         |
| $V_{th}$   | Input threshold voltage         | AWD only  | 1.35                            | 1.8              | V        |         |
| $RDS_{ON}$ | Drain to source on resistance   | AWD only§   | $V_{OL} = 0.35V @ I_{OL} = 8mA$ |                  | $\Omega$ |         |
| $V_{OL}$   | Low-level output voltage¶       | $I_{OL} = I_{OL} MAX$   | $0.2 V_{CCIO}$                  |                  | V        |         |
|            |                                 | $I_{OL} = 50 \mu A$   | 0.2                             |                  |          |         |
| $V_{OH}$   | High-level output voltage¶      | $I_{OH} = I_{OH} MIN$   | $0.8 V_{CCIO}$                  |                  | V        |         |
|            |                                 | $I_{OH} = 50 \mu A$   | $V_{CCIO} - 0.2$                |                  |          |         |
| $I_{IC}$   | Input clamp current (I/O pins)# | $V_I < V_{SSIO} - 0.3$ or $V_I > V_{CCIO} + 0.3$              | -2                              | 2                | mA       |         |
| $I_I$      | Input current (I/O pins)        | $I_{IL}$ Pulldown   | $V_I = V_{SS}$                  | -1               | 1        | $\mu A$ |
|            |                                 | $I_{IH}$ Pulldown   | $V_I = V_{CCIO}$                | 5                | 40       |         |
|            |                                 | $I_{IL}$ Pullup   | $V_I = V_{SS}$                  | -40              | -5       |         |
|            |                                 | $I_{IH}$ Pullup   | $V_I = V_{CCIO}$                | -1               | 1        |         |
|            |                                 | All other pins  | No pullup or pulldown           | -1               | 1        |         |
| $I_{OL}$   | Low-level output current        | CLKOUT, AWD, TDO  | $V_{OL} = V_{OL} MAX$           | 8                |          | mA      |
|            |                                 | RST, SPI1CLK, SPI1SOMI, SPI1SIMO, SPI2CLK, SPI2SOMI, SPI2SIMO | $V_{OL} = V_{OL} MAX$           | 4                |          |         |
|            |                                 | All other output pins¶¶                                       | $V_{OL} = V_{OL} MAX$           | 2                |          |         |
| $I_{OH}$   | High-level output current       | CLKOUT, TDO   | $V_{OH} = V_{OH} MIN$           | -8               |          | mA      |
|            |                                 | SPI1CLK, SPI1SOMI, SPI1SIMO, SPI2CLK, SPI2SOMI, SPI2SIMO      | $V_{OH} = V_{OH} MIN$           | -4               |          |         |
|            |                                 | All other output pins except RST¶¶                            | $V_{OH} = V_{OH} MIN$           | -2               |          |         |

† Source currents (out of the device) are negative while sink currents (into the device) are positive.

‡ This does not apply to the PORRST pin. For PORRST exceptions, see the RST and PORRST timings section on page 30.

§ These values help to determine the external RC network circuit. For more details, see the *TMS470R1x System Module Reference Guide* (literature number SPNU189).

¶  $V_{OL}$  and  $V_{OH}$  are linear with respect to the amount of load current ( $I_{OL}/I_{OH}$ ) applied.

# Parameter does not apply to input-only or output-only pins.

¶¶ The 2 mA buffers on this device are called zero-dominant buffers. If two of these buffers are shorted together and one is outputting a low level and the other is outputting a high level, the resulting value will always be low.

Ⓢ I/O pins configured as inputs or outputs with no load. All pulldown inputs  $\leq 0.2$  V. All pullup inputs  $\geq V_{CCIO} - 0.2$  V.

# TMS470R1VC336, TMS470R1VC346 16/32-BIT RISC ROM MICROCONTROLLERS

SPNS084E – MAY 2003 – REVISED AUGUST 2006

electrical characteristics over recommended operating free-air temperature range, Q version  
(unless otherwise noted) (continued)<sup>†</sup>

| PARAMETER         |   | TEST CONDITIONS   | MIN | TYP | MAX | UNIT |
|-------------------|---|---|-----|-----|-----|------|
| I <sub>CC</sub>   | V <sub>CC</sub> Digital supply current (operating mode)   | SYSCLK = 48 MHz,<br>ICLK = 24 MHz, V <sub>CC</sub> = 2.06 V |     |     | 50  | mA   |
|                   |   | SYSCLK = 24 MHz,<br>ICLK = 12 MHz, V <sub>CC</sub> = 2.06 V |     |     | 35  | mA   |
|                   | V <sub>CC</sub> Digital supply current (standby mode)     | OSCIN = 6 MHz, V <sub>CC</sub> = 2.06 V                     |     |     | 3.0 | mA   |
|                   | V <sub>CC</sub> Digital supply current (halt mode)        | V <sub>CC</sub> = 2.06 V                                    |     |     | 1.0 | mA   |
| I <sub>CCIO</sub> | V <sub>CCIO</sub> Digital supply current (operating mode) | No DC load, V <sub>CCIO</sub> = 3.6 V <sup>‡</sup>          |     |     | 10  | mA   |
|                   | V <sub>CCIO</sub> Digital supply current (standby mode)   | No DC load, V <sub>CCIO</sub> = 3.6 V <sup>‡</sup>          |     |     | 300 | μA   |
|                   | V <sub>CCIO</sub> Digital supply current (halt mode)      | No DC load, V <sub>CCIO</sub> = 3.6 V <sup>‡</sup>          |     |     | 300 | μA   |
| I <sub>CCAD</sub> | V <sub>CCAD</sub> supply current (operating mode)         | All frequencies, V <sub>CCAD</sub> = 3.6 V                  |     |     | 18  | mA   |
|                   | V <sub>CCAD</sub> supply current (standby mode)           | All frequencies, V <sub>CCAD</sub> = 3.6 V                  |     |     | 20  | μA   |
|                   | V <sub>CCAD</sub> supply current (halt mode)              | V <sub>CCAD</sub> = 3.6 V                                   |     |     | 20  | μA   |
| C <sub>I</sub>    | Input capacitance   |   |     | 2   |     | pF   |
| C <sub>O</sub>    | Output capacitance  |   |     | 3   |     | pF   |

<sup>†</sup> Source currents (out of the device) are negative while sink currents (into the device) are positive.

<sup>‡</sup> This does not apply to the PORRST pin. For PORRST exceptions, see the RST and PORRST timings section on page 30.

<sup>§</sup> These values help to determine the external RC network circuit. For more details, see the *TMS470R1x System Module Reference Guide* (literature number SPNU189).

<sup>¶</sup> V<sub>OL</sub> and V<sub>OH</sub> are linear with respect to the amount of load current (I<sub>OL</sub>/I<sub>OH</sub>) applied.

<sup>#</sup> Parameter does not apply to input-only or output-only pins.

<sup>||</sup> The 2 mA buffers on this device are called zero-dominant buffers. If two of these buffers are shorted together and one is outputting a low level and the other is outputting a high level, the resulting value will always be low.

<sup>⊗</sup> I/O pins configured as inputs or outputs with no load. All pulldown inputs ≤ 0.2 V. All pullup inputs ≥ V<sub>CCIO</sub> – 0.2 V.

## PARAMETER MEASUREMENT INFORMATION

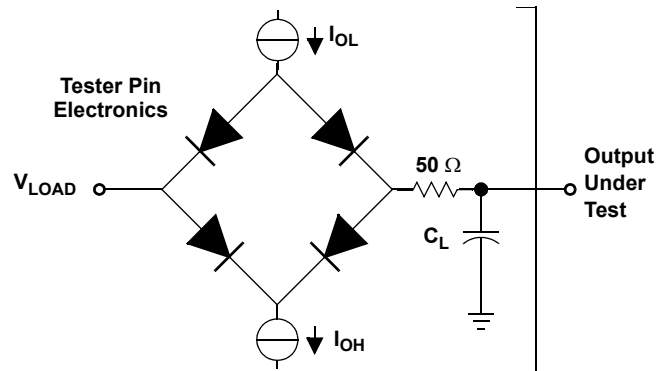

Where:  $I_{OL}$  =  $I_{OL}$  MAX for the respective pin (see Note A)  
 $I_{OH}$  =  $I_{OH}$  MIN for the respective pin (see Note A)  
 $V_{LOAD}$  = 1.5 V  
 $C_L$  = 150-pF typical load-circuit capacitance (see Note B)

NOTES: A. For these values, see the electrical characteristics over recommended operating free-air temperature range table.  
B. All timing parameters measured using an external load capacitance of 150 pF unless otherwise noted.

**Figure 3. Test Load Circuit**

# TMS470R1VC336, TMS470R1VC346 16/32-BIT RISC ROM MICROCONTROLLERS

SPNS084E – MAY 2003 – REVISED AUGUST 2006

---

## timing parameter symbology

Timing parameter symbols have been created in accordance with JEDEC Standard 100. In order to shorten the symbols, some of the pin names and other related terminology have been abbreviated as follows:

|           |                        |      |                                |
|-----------|------------------------|------|--------------------------------|
| CM        | Compaction, CMPCT      | RD   | Read                           |
| CO        | CLKOUT                 | RST  | Reset, $\overline{\text{RST}}$ |
| ER        | Erase                  | RX   | SCInRX                         |
| ICLK      | Interface clock        | S    | Slave mode                     |
| M         | Master mode            | SCC  | SCInCLK                        |
| OSC, OSC1 | OSCIN                  | SIMO | SPInSIMO                       |
| OSCO      | OSCOU                  | SOMI | SPInSOMI                       |
| P         | Program, PROG          | SPC  | SPInCLK                        |
| R         | Ready                  | SYS  | System clock                   |
| R0        | Read margin 0, RDMRGN0 | TX   | SCInTX                         |
| R1        | Read margin 1, RDMRGN1 |      |                                |

Lowercase subscripts and their meanings are:

|   |                     |    |                        |
|---|---------------------|----|------------------------|
| a | access time         | r  | rise time              |
| c | cycle time (period) | su | setup time             |
| d | delay time          | t  | transition time        |
| f | fall time           | v  | valid time             |
| h | hold time           | w  | pulse duration (width) |

The following additional letters are used with these meanings:

|   |       |   |  |
|---|-------|---|--|
| H | High  | X | Unknown, changing, or don't care level |
| L | Low   | Z | High impedance                         |
| V | Valid |   |  |

## external reference resonator/crystal oscillator clock option

The oscillator is enabled by connecting the appropriate fundamental 4–20 MHz resonator/crystal and load capacitors across the external OSCIN and OSCOUT pins as shown in Figure 4a. The oscillator is a single-stage inverter held in bias by an integrated bias resistor. This resistor is disabled during leakage test measurement and HALT mode. **TI strongly encourages each customer to submit samples of the device to the resonator/crystal vendors for validation.** The vendors are equipped to determine what load capacitors will best tune their resonator/crystal to the microcontroller device for optimum start-up and operation over temperature/voltage extremes.

An external oscillator source can be used by connecting a 1.8 V clock signal to the OSCIN pin and leaving the OSCOUT pin unconnected (open) as shown in Figure 4b.

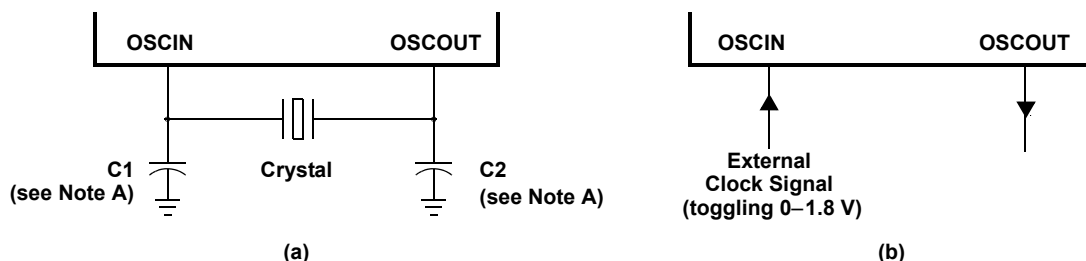

NOTE A: The values of C1 and C2 should be provided by the resonator/crystal vendor.

**Figure 4. Crystal/Clock Connection**

# TMS470R1VC336, TMS470R1VC346 16/32-BIT RISC ROM MICROCONTROLLERS

SPNS084E – MAY 2003 – REVISED AUGUST 2006

## ZPLL and clock specifications

### timing requirements for ZPLL circuits enabled or disabled

|                |                                 | MIN | TYP | MAX | UNIT |
|----------------|---------------------------------|-----|-----|-----|------|
| $f_{(OSC)}$    | Input clock frequency           | 4   |     | 20  | MHz  |
| $t_{c(OSC)}$   | Cycle time, OSCIN               | 50  |     |     | ns   |
| $t_{w(OSCIL)}$ | Pulse duration, OSCIN low       | 15  |     |     | ns   |
| $t_{w(OSCIH)}$ | Pulse duration, OSCIN high      | 15  |     |     | ns   |
| $f_{(OSCRST)}$ | OSC FAIL frequency <sup>†</sup> |     | 53  |     | kHz  |

<sup>†</sup> Causes a device reset (specifically a clock reset) by setting the RST OSC FAIL (GLBCTRL.15) and the OSC FAIL flag (GLBSTAT.1) bits equal to 1. For more detailed information on these bits and device resets, see the *TMS470R1x System Module Reference Guide* (literature number SPNU189).

### switching characteristics over recommended operating conditions for clocks<sup>‡§</sup>

| PARAMETER     |  | TEST CONDITIONS <sup>¶</sup>        | MIN  | MAX | UNIT |
|---------------|--|-------------------------------------|------|-----|------|
| $f_{(SYS)}$   | System clock frequency                         | Pipeline mode enabled               |      | 48  | MHz  |
|               |  | Pipeline mode disabled (VC346 only) |      | 24  |      |
|               |  | Pipeline mode disabled (VC336 only) |      | 28  |      |
| $f_{(ICLK)}$  | Interface clock frequency                      | Pipeline mode enabled               |      | 25  | MHz  |
|               |  | Pipeline mode disabled              |      | 24  |      |
| $f_{(ECLK)}$  | External clock output frequency for ECP Module | Pipeline mode enabled               |      | 25  | MHz  |
|               |  | Pipeline mode disabled              |      | 24  |      |
| $t_{c(SYS)}$  | Cycle time, system clock                       | Pipeline mode enabled               | 20.8 |     | ns   |
|               |  | Pipeline mode disabled (VC346 only) | 41.6 |     |      |
|               |  | Pipeline mode disabled (VC336 only) | 35.7 |     |      |
| $t_{c(ICLK)}$ | Cycle time, interface clock                    | Pipeline mode enabled               | 40   |     | ns   |
|               |  | Pipeline mode disabled              | 41.6 |     |      |
| $t_{c(ECLK)}$ | Cycle time, ECP module external clock output   | Pipeline mode enabled               | 40   |     | ns   |
|               |  | Pipeline mode disabled              | 41.6 |     |      |

<sup>‡</sup>  $f_{(SYS)} = M \times f_{(OSC)} / R$ , where  $M = \{4 \text{ or } 8\}$ ,  $R = \{1, 2, 3, 4, 5, 6, 7, 8\}$  when  $PLLDIS = 0$ . R is the system-clock divider determined by the CLKDIVPRE [2:0] bits in the global control register (GLBCTRL.[2:0]) and M is the PLL multiplier determined by the MULT4 bit also in the GLBCTRL register (GLBCTRL.3).

$f_{(SYS)} = f_{(OSC)} / R$ , where  $R = \{1, 2, 3, 4, 5, 6, 7, 8\}$  when  $PLLDIS = 1$ .

$f_{(ICLK)} = f_{(SYS)} / X$ , where  $X = \{1, 2, 3, 4, 5, 6, 7, 8, 9, 10, 11, 12, 13, 14, 15, 16\}$ . X is the interface clock divider ratio determined by the PCR0.[4:1] bits in the SYS module.

<sup>§</sup>  $f_{(ECLK)} = f_{(ICLK)} / N$ , where  $N = \{1 \text{ to } 256\}$ . N is the ECP prescale value defined by the ECPCTRL.[7:0] register bits in the ECP module.

<sup>¶</sup> Pipeline mode enabled or disabled is determined by the ENPIPE bit (REGOPT.0).

ZPLL and clock specifications (continued)

switching characteristics over recommended operating conditions for external clocks  
(see Figure 5 and Figure 6)<sup>†‡§</sup>

| NO. | PARAMETER                                | TEST CONDITIONS                       | MIN                                    | MAX | UNIT |
|-----|--|---------------------------------------|--|-----|------|
| 1   | $t_{w(COL)}$ Pulse duration, CLKOUT low  | SYSCLK or MCLK <sup>††</sup>          | $0.5t_{c(SYS)} - t_f$                  |     | ns   |
|     |  | ICLK, X is even or 1 <sup>#</sup>     | $0.5t_{c(ICLK)} - t_f$                 |     |      |
|     |  | ICLK, X is odd and not 1 <sup>#</sup> | $0.5t_{c(ICLK)} + 0.5t_{c(SYS)} - t_f$ |     |      |
| 2   | $t_{w(COH)}$ Pulse duration, CLKOUT high | SYSCLK or MCLK <sup>††</sup>          | $0.5t_{c(SYS)} - t_r$                  |     | ns   |
|     |  | ICLK, X is even or 1 <sup>#</sup>     | $0.5t_{c(ICLK)} - t_r$                 |     |      |
|     |  | ICLK, X is odd and not 1 <sup>#</sup> | $0.5t_{c(ICLK)} - 0.5t_{c(SYS)} - t_r$ |     |      |
| 3   | $t_{w(EOL)}$ Pulse duration, ECLK low    | N is even and X is even or odd        | $0.5t_{c(ECLK)} - t_f$                 |     | ns   |
|     |  | N is odd and X is even                | $0.5t_{c(ECLK)} - t_f$                 |     |      |
|     |  | N is odd and X is odd and not 1       | $0.5t_{c(ECLK)} + 0.5t_{c(SYS)} - t_f$ |     |      |
| 4   | $t_{w(EOH)}$ Pulse duration, ECLK high   | N is even and X is even or odd        | $0.5t_{c(ECLK)} - t_r$                 |     | ns   |
|     |  | N is odd and X is even                | $0.5t_{c(ECLK)} - t_r$                 |     |      |
|     |  | N is odd and X is odd and not 1       | $0.5t_{c(ECLK)} - 0.5t_{c(SYS)} - t_r$ |     |      |

<sup>†</sup> X = {1,2,3,4,5,6,7,8,9,10,11,12,13,14,15,16}. X is the interface clock divider ratio determined by the PCR0.[4:1] bits in the SYS module.

<sup>‡</sup> N = {1 to 256}. N is the ECP prescale value defined by the ECPCTRL.[7:0] register bits in the ECP module.

<sup>§</sup> CLKOUT/ECLK pulse durations (low/high) are a function of the OSCIN pulse durations when PLLDIS is active.

<sup>††</sup> Clock source bits selected as either SYSCLK (CLKCNTL.[6:5] = 11 binary) or MCLK (CLKCNTL.[6:5] = 10 binary).

<sup>#</sup> Clock source bits selected as ICLK (CLKCNTL.[6:5] = 01 binary).

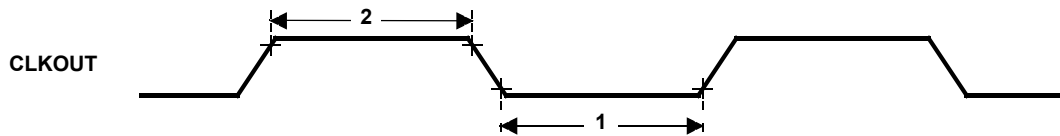

Figure 5. CLKOUT Timing Diagram

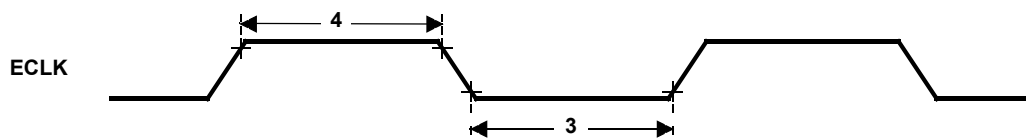

Figure 6. ECLK Timing Diagram



# TMS470R1VC336, TMS470R1VC346 16/32-BIT RISC ROM MICROCONTROLLERS

SPNS084E – MAY 2003 – REVISED AUGUST 2006

## RST and PORRST timings

### timing requirements for PORRST (see Figure 7)

| NO. |   | MIN  | MAX            | UNIT    |
|-----|---|------|----------------|---------|
|     | $V_{CCPORL}$ $V_{CC}$ low supply level when $\overline{PORRST}$ must be active during power up  |      | 0.6            | V       |
|     | $V_{CCPORH}$ $V_{CC}$ high supply level when $\overline{PORRST}$ must remain active during power up and become active during power down     | 1.5  |                | V       |
|     | $V_{CCIOPORL}$ $V_{CCIO}$ low supply level when $\overline{PORRST}$ must be active during power up  |      | 1.1            | V       |
|     | $V_{CCIOPORH}$ $V_{CCIO}$ high supply level when $\overline{PORRST}$ must remain active during power up and become active during power down | 2.75 |                | V       |
|     | $V_{IL}$ Low-level input voltage after $V_{CCIO} > V_{CCIOPORH}$  |      | $0.2 V_{CCIO}$ | V       |
|     | $V_{IL(PORRST)}$ Low-level input voltage of $\overline{PORRST}$ before $V_{CCIO} > V_{CCIOPORL}$  |      | 0.5            | V       |
| 3   | $t_{su(PORRST)r}$ Setup time, $\overline{PORRST}$ active before $V_{CCIO} > V_{CCIOPORL}$ during power up                                   | 0    |                | ms      |
| 5   | $t_{su(VCCIO)r}$ Setup time, $V_{CCIO} > V_{CCIOPORL}$ before $V_{CC} > V_{CCPORL}$   | 0    |                | ms      |
| 6   | $t_{h(PORRST)r}$ Hold time, $\overline{PORRST}$ active after $V_{CC} > V_{CCPORH}$  | 1    |                | ms      |
| 7   | $t_{su(PORRST)f}$ Setup time, $\overline{PORRST}$ active before $V_{CC} \leq V_{CCPORH}$ during power down                                  | 8    |                | $\mu$ s |
| 8   | $t_{h(PORRST)rio}$ Hold time, $\overline{PORRST}$ active after $V_{CC} > V_{CCIOPORH}$  | 1    |                | ms      |
| 9   | $t_{h(PORRST)d}$ Hold time, $\overline{PORRST}$ active after $V_{CC} < V_{CCPORL}$  | 0    |                | ms      |
| 10  | $t_{su(PORRST)rio}$ Setup time, $\overline{PORRST}$ active before $V_{CC} \leq V_{CCIOPORH}$ during power down                              | 0    |                | ns      |
| 11  | $t_{su(VCCIO)f}$ Setup time, $V_{CC} < V_{CCPORL}$ before $V_{CCIO} < V_{CCIOPORL}$   | 0    |                | ns      |

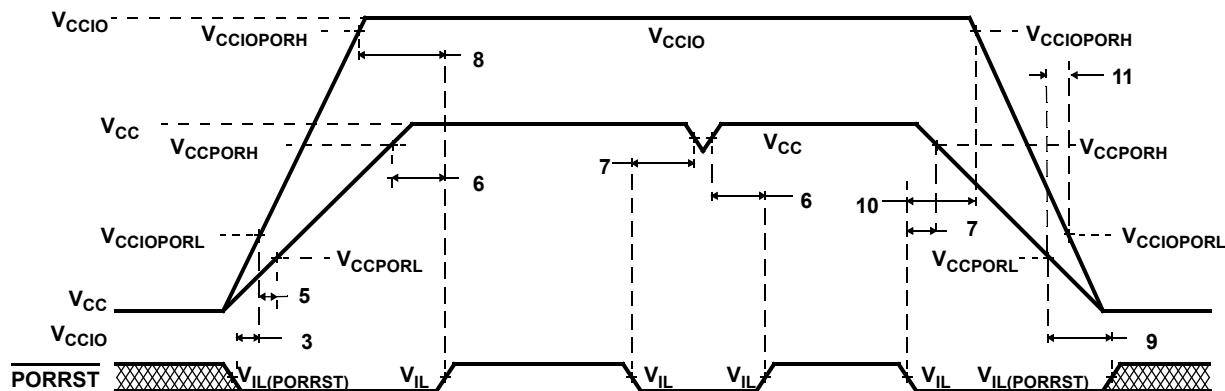

Figure 7.  $\overline{PORRST}$  Timing Diagram

### switching characteristics over recommended operating conditions for RST<sup>†</sup>

| PARAMETER    |  | MIN              | MAX | UNIT |
|--------------|--|------------------|-----|------|
| $t_{v(RST)}$ | Valid time, RST active after PORRST inactive | $4112t_{c(OSC)}$ |     | ns   |
|              | Valid time, RST active (all others)          | $8t_{c(SYS)}$    |     |      |

<sup>†</sup> Specified values do NOT include rise/fall times. For rise and fall timings, see the switching characteristics for output timings versus load capacitance table.

# TMS470R1VC336, TMS470R1VC346 16/32-BIT RISC ROM MICROCONTROLLERS

SPNS084E – MAY 2003 – REVISED AUGUST 2006

## JTAG scan interface timing (JTAG clock specification 10-MHz and 50-pF load on TDO output)

| NO. |  | MIN | MAX | UNIT |
|-----|--|-----|-----|------|
| 1   | $t_{c(JTAG)}$ Cycle time, JTAG low and high period                   | 50  |     | ns   |
| 2   | $t_{su(TDI/TMS - TCKr)}$ Setup time, TDI, TMS before TCK rise (TCKr) | 15  |     | ns   |
| 3   | $t_h(TCKr - TDI/TMS)$ Hold time, TDI, TMS after TCKr                 | 15  |     | ns   |
| 4   | $t_h(TCKf - TDO)$ Hold time, TDO after TCKf                          | 10  |     | ns   |
| 5   | $t_d(TCKf - TDO)$ Delay time, TDO valid after TCK fall (TCKf)        |     | 45  | ns   |

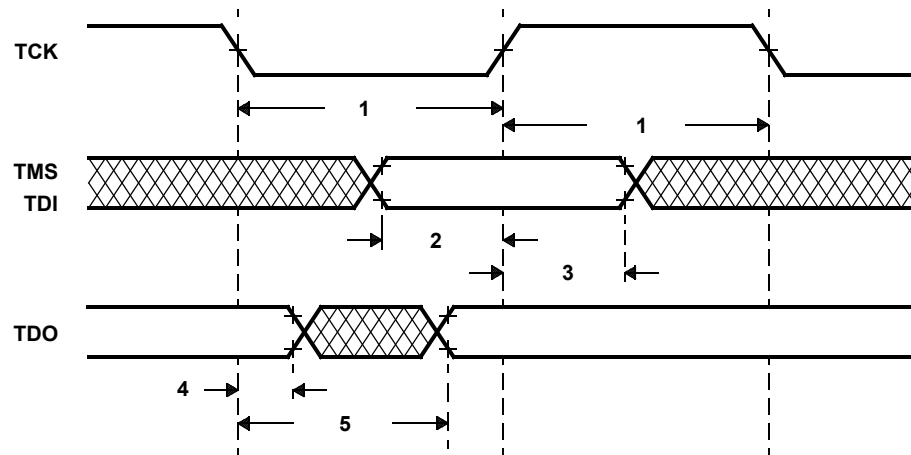

Figure 8. JTAG Scan Timing

# TMS470R1VC336, TMS470R1VC346 16/32-BIT RISC ROM MICROCONTROLLERS

SPNS084E – MAY 2003 – REVISED AUGUST 2006

## output timings

switching characteristics for output timings versus load capacitance ( $C_L$ ) (see Figure 9)

| PARAMETER |   | MIN                    | MAX | UNIT |    |
|-----------|---|------------------------|-----|------|----|
| $t_r$     | Rise time, CLKOUT, AWD, TDO   | $C_L = 15 \text{ pF}$  | 0.5 | 2.50 | ns |
|           |   | $C_L = 50 \text{ pF}$  | 1.5 | 5    |    |
|           |   | $C_L = 100 \text{ pF}$ | 3   | 9    |    |
|           |   | $C_L = 150 \text{ pF}$ | 4.5 | 12.5 |    |
| $t_f$     | Fall time, CLKOUT, AWD, TDO   | $C_L = 15 \text{ pF}$  | 0.5 | 2.5  | ns |
|           |   | $C_L = 50 \text{ pF}$  | 1.5 | 5    |    |
|           |   | $C_L = 100 \text{ pF}$ | 3   | 9    |    |
|           |   | $C_L = 150 \text{ pF}$ | 4.5 | 12.5 |    |
| $t_r$     | Rise time, SPI1CLK, SPI1SOMI, SPI1SIMO, SPI2CLK, SPI2SOMI, SPI2SIMO                           | $C_L = 15 \text{ pF}$  | 2.5 | 8    | ns |
|           |   | $C_L = 50 \text{ pF}$  | 5   | 14   |    |
|           |   | $C_L = 100 \text{ pF}$ | 9   | 23   |    |
|           |   | $C_L = 150 \text{ pF}$ | 13  | 32   |    |
| $t_f$     | Fall time, $\overline{\text{RST}}$ , SPI1CLK, SPI1SOMI, SPI1SIMO, SPI2CLK, SPI2SOMI, SPI2SIMO | $C_L = 15 \text{ pF}$  | 2.5 | 8    | ns |
|           |   | $C_L = 50 \text{ pF}$  | 5   | 14   |    |
|           |   | $C_L = 100 \text{ pF}$ | 9   | 23   |    |
|           |   | $C_L = 150 \text{ pF}$ | 13  | 32   |    |
| $t_r$     | Rise time, all other output pins  | $C_L = 15 \text{ pF}$  | 2.5 | 10   | ns |
|           |   | $C_L = 50 \text{ pF}$  | 6.0 | 25   |    |
|           |   | $C_L = 100 \text{ pF}$ | 12  | 45   |    |
|           |   | $C_L = 150 \text{ pF}$ | 18  | 65   |    |
| $t_f$     | Fall time, all other output pins  | $C_L = 15 \text{ pF}$  | 3   | 10   | ns |
|           |   | $C_L = 50 \text{ pF}$  | 8.5 | 25   |    |
|           |   | $C_L = 100 \text{ pF}$ | 16  | 45   |    |
|           |   | $C_L = 150 \text{ pF}$ | 23  | 65   |    |

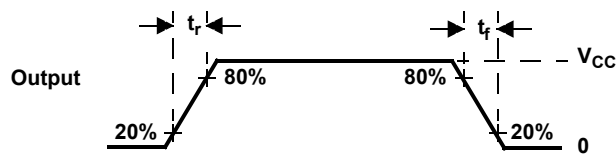

Figure 9. CMOS-Level Outputs

input timings

timing requirements for input timings<sup>†</sup> (see Figure 10)

|                                    | MIN                | MAX | UNIT |
|------------------------------------|--------------------|-----|------|
| $t_{pw}$ Input minimum pulse width | $t_{c(ICLK)} + 10$ |     | ns   |

<sup>†</sup>  $t_{c(ICLK)}$  = interface clock cycle time =  $1/f_{(ICLK)}$

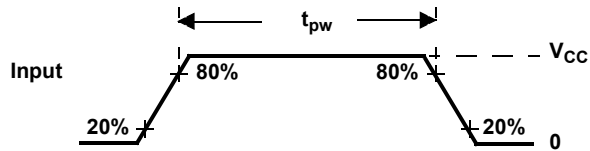

Figure 10. CMOS-Level Inputs

# TMS470R1VC336, TMS470R1VC346 16/32-BIT RISC ROM MICROCONTROLLERS

SPNS084E – MAY 2003 – REVISED AUGUST 2006

## SPIn master mode timing parameters

SPIn master mode external timing parameters (CLOCK PHASE = 0, SPInCLK = output, SPInSIMO = output, and SPInSOMI = input)<sup>†‡§</sup> (see Figure 11)

| NO.            |   | MIN                         | MAX                  | UNIT |
|----------------|---|-----------------------------|----------------------|------|
| 1              | $t_{c(SPC)M}$ Cycle time, SPInCLK <sup>¶</sup>  | 100                         | $256t_{c(ICLK)}$     | ns   |
| 2 <sup>#</sup> | $t_w(SPCH)M$ Pulse duration, SPInCLK high (clock polarity = 0)                            | $0.5t_{c(SPC)M} - t_r$      | $0.5t_{c(SPC)M} + 5$ | ns   |
|                | $t_w(SPCL)M$ Pulse duration, SPInCLK low (clock polarity = 1)                             | $0.5t_{c(SPC)M} - t_f$      | $0.5t_{c(SPC)M} + 5$ |      |
| 3 <sup>#</sup> | $t_w(SPCL)M$ Pulse duration, SPInCLK low (clock polarity = 0)                             | $0.5t_{c(SPC)M} - t_r$      | $0.5t_{c(SPC)M} + 5$ | ns   |
|                | $t_w(SPCH)M$ Pulse duration, SPInCLK high (clock polarity = 1)                            | $0.5t_{c(SPC)M} - t_r$      | $0.5t_{c(SPC)M} + 5$ |      |
| 4 <sup>#</sup> | $t_d(SPCH-SIMO)M$ Delay time, SPInCLK high to SPInSIMO valid (clock polarity = 0)         |                             | 10                   | ns   |
|                | $t_d(SPCL-SIMO)M$ Delay time, SPInCLK low to SPInSIMO valid (clock polarity = 1)          |                             | 10                   |      |
| 5 <sup>#</sup> | $t_v(SPCL-SIMO)M$ Valid time, SPInSIMO data valid   | $t_{c(SPC)M} - 5 - t_{r/f}$ |                      | ns   |
| 6 <sup>#</sup> | $t_{su}(SOMI-SPCL)M$ Setup time, SPInSOMI before SPInCLK low (clock polarity = 0)         | 6                           |                      | ns   |
|                | $t_{su}(SOMI-SPCH)M$ Setup time, SPInSOMI before SPInCLK high (clock polarity = 1)        | 6                           |                      |      |
| 7 <sup>#</sup> | $t_v(SPCL-SOMI)M$ Valid time, SPInSOMI data valid after SPInCLK low (clock polarity = 0)  | 4                           |                      | ns   |
|                | $t_v(SPCH-SOMI)M$ Valid time, SPInSOMI data valid after SPInCLK high (clock polarity = 1) | 4                           |                      |      |

† The MASTER bit (SPInCTRL2.3) is set and the CLOCK PHASE bit (SPInCTRL2.0) is cleared.

‡  $t_{c(ICLK)}$  = interface clock cycle time =  $1/f_{(ICLK)}$

§ For rise and fall timings, see the "switching characteristics for output timings versus load capacitance" table.

¶ When the SPI is in Master mode, the following must be true:

For PS values from 1 to 255:  $t_{c(SPC)M} \geq (PS + 1)t_{c(ICLK)} \geq 100$  ns, where PS is the prescale value set in the SPInCTL1.[12:5] register bits.

For PS values of 0:  $t_{c(SPC)M} = 2t_{c(ICLK)} \geq 100$  ns.

# The active edge of the SPInCLK signal referenced is controlled by the CLOCK POLARITY bit (SPInCTRL2.1).

**SPIn master mode timing parameters (continued)**

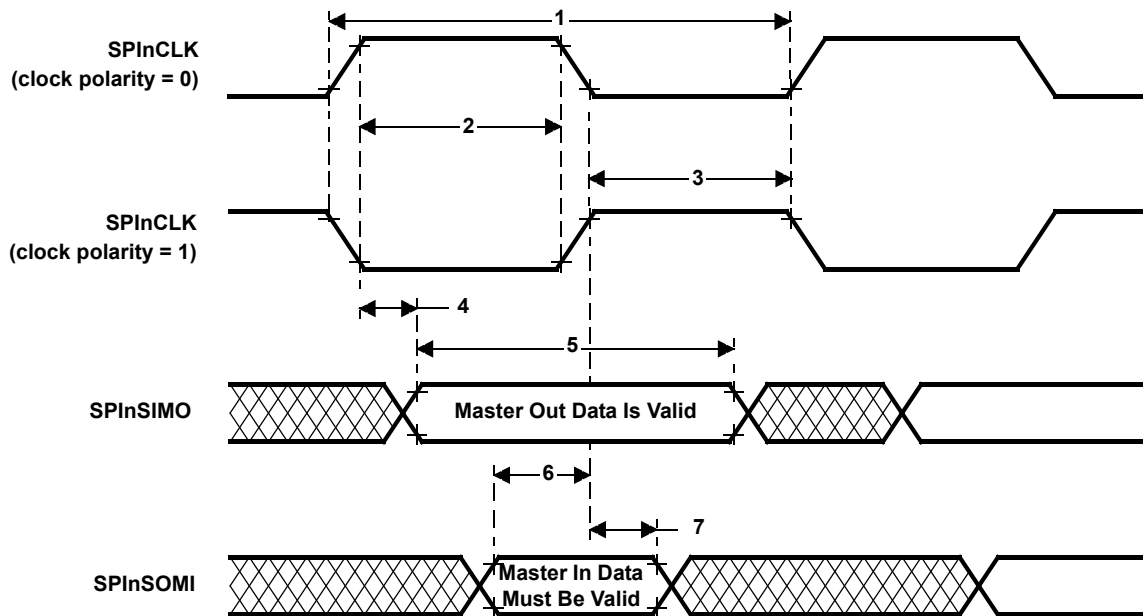

**Figure 11. SPIn Master Mode External Timing (CLOCK PHASE = 0)**

# TMS470R1VC336, TMS470R1VC346 16/32-BIT RISC ROM MICROCONTROLLERS

SPNS084E – MAY 2003 – REVISED AUGUST 2006

## SPIn master mode timing parameters (continued)

SPIn master mode external timing parameters (CLOCK PHASE = 1, SPInCLK = output, SPInSIMO = output, and SPInSOMI = input)<sup>†‡§</sup> (see Figure 12)

| NO.            |                      |   | MIN                        | MAX                  | UNIT |
|----------------|----------------------|---|----------------------------|----------------------|------|
| 1              | $t_{c(SPC)M}$        | Cycle time, SPInCLK <sup>¶</sup>  | 100                        | $256t_{c(ICLK)}$     | ns   |
| 2 <sup>#</sup> | $t_{w(SPCH)M}$       | Pulse duration, SPInCLK high (clock polarity = 0)                       | $0.5t_{c(SPC)M} - t_r$     | $0.5t_{c(SPC)M} + 5$ | ns   |
|                | $t_{w(SPCL)M}$       | Pulse duration, SPInCLK low (clock polarity = 1)                        | $0.5t_{c(SPC)M} - t_f$     | $0.5t_{c(SPC)M} + 5$ |      |
| 3 <sup>#</sup> | $t_{w(SPCL)M}$       | Pulse duration, SPInCLK low (clock polarity = 0)                        | $0.5t_{c(SPC)M} - t_f$     | $0.5t_{c(SPC)M} + 5$ | ns   |
|                | $t_{w(SPCH)M}$       | Pulse duration, SPInCLK high (clock polarity = 1)                       | $0.5t_{c(SPC)M} - t_r$     | $0.5t_{c(SPC)M} + 5$ |      |
| 4 <sup>#</sup> | $t_{v(SIMO-SPCH)M}$  | Valid time, SPInCLK high after SPInSIMO data valid (clock polarity = 0) | $0.5t_{c(SPC)M} - 10$      |                      | ns   |
|                | $t_{v(SIMO-SPCL)M}$  | Valid time, SPInCLK low after SPInSIMO data valid (clock polarity = 1)  | $0.5t_{c(SPC)M} - 10$      |                      |      |
| 5 <sup>#</sup> | $t_{v(SPCH-SIMO)M}$  | Valid time, SPInSIMO data valid after SPInCLK high (clock polarity = 0) | $0.5t_{c(SPC)M} - 5 - t_r$ |                      | ns   |
|                | $t_{v(SPCL-SIMO)M}$  | Valid time, SPInSIMO data valid after SPInCLK low (clock polarity = 1)  | $0.5t_{c(SPC)M} - 5 - t_f$ |                      |      |
| 6 <sup>#</sup> | $t_{su(SOMI-SPCH)M}$ | Setup time, SPInSOMI before SPInCLK high (clock polarity = 0)           | 6                          |                      | ns   |
|                | $t_{su(SOMI-SPCL)M}$ | Setup time, SPInSOMI before SPInCLK low (clock polarity = 1)            | 6                          |                      |      |
| 7 <sup>#</sup> | $t_{v(SPCH-SOMI)M}$  | Valid time, SPInSOMI data valid after SPInCLK high (clock polarity = 0) | 4                          |                      | ns   |
|                | $t_{v(SPCL-SOMI)M}$  | Valid time, SPInSOMI data valid after SPInCLK low (clock polarity = 1)  | 4                          |                      |      |

† The MASTER bit (SPInCTRL2.3) is set and the CLOCK PHASE bit (SPInCTRL2.0) is set.

‡  $t_{c(ICLK)}$  = interface clock cycle time =  $1/f_{(ICLK)}$

§ For rise and fall timings, see the "switching characteristics for output timings versus load capacitance" table.

¶ When the SPI is in Master mode, the following must be true:

For PS values from 1 to 255:  $t_{c(SPC)M} \geq (PS + 1)t_{c(ICLK)} \geq 100$  ns, where PS is the prescale value set in the SPInCTL1.[12:5] register bits.

For PS values of 0:  $t_{c(SPC)M} = 2t_{c(ICLK)} \geq 100$  ns.

# The active edge of the SPInCLK signal referenced is controlled by the CLOCK POLARITY bit (SPInCTRL2.1).



SPIn master mode timing parameters (continued)

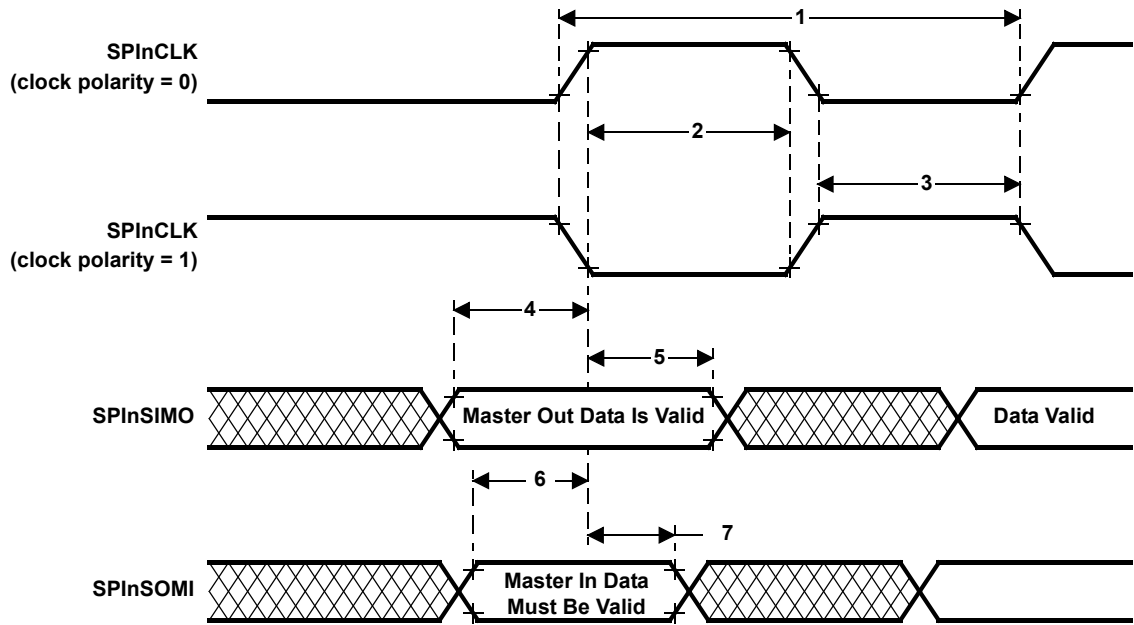

Figure 12. SPIn Master Mode External Timing (CLOCK PHASE = 1)

# TMS470R1VC336, TMS470R1VC346 16/32-BIT RISC ROM MICROCONTROLLERS

SPNS084E – MAY 2003 – REVISED AUGUST 2006

## SPIn slave mode timing parameters

SPIn slave mode external timing parameters (CLOCK PHASE = 0, SPInCLK = input, SPInSIMO = input, and SPInSOMI = output)<sup>†‡§¶</sup> (see Figure 13)

| NO.             |   | MIN                                | MAX                                | UNIT |
|-----------------|---|------------------------------------|------------------------------------|------|
| 1               | $t_{c(SPC)S}$ Cycle time, SPInCLK <sup>#</sup>  | 100                                | $256t_{c(ICLK)}$                   | ns   |
| 2 <sup>  </sup> | $t_{w(SPCH)S}$ Pulse duration, SPInCLK high (clock polarity = 0)                            | $0.5t_{c(SPC)S} - 0.25t_{c(ICLK)}$ | $0.5t_{c(SPC)S} + 0.25t_{c(ICLK)}$ | ns   |
|                 | $t_{w(SPCL)S}$ Pulse duration, SPInCLK low (clock polarity = 1)                             | $0.5t_{c(SPC)S} - 0.25t_{c(ICLK)}$ | $0.5t_{c(SPC)S} + 0.25t_{c(ICLK)}$ |      |
| 3 <sup>  </sup> | $t_{w(SPCL)S}$ Pulse duration, SPInCLK low (clock polarity = 0)                             | $0.5t_{c(SPC)S} - 0.25t_{c(ICLK)}$ | $0.5t_{c(SPC)S} + 0.25t_{c(ICLK)}$ | ns   |
|                 | $t_{w(SPCH)S}$ Pulse duration, SPInCLK high (clock polarity = 1)                            | $0.5t_{c(SPC)S} - 0.25t_{c(ICLK)}$ | $0.5t_{c(SPC)S} + 0.25t_{c(ICLK)}$ |      |
| 4 <sup>  </sup> | $t_{d(SPCH-SOMI)S}$ Delay time, SPInCLK high to SPInSOMI valid (clock polarity = 0)         |                                    | $6 + t_r$                          | ns   |
|                 | $t_{d(SPCL-SOMI)S}$ Delay time, SPInCLK low to SPInSOMI valid (clock polarity = 1)          |                                    | $6 + t_f$                          |      |
| 5 <sup>  </sup> | $t_{v(SPCH-SOMI)S}$ Valid time, SPInSOMI data valid after SPInCLK high (clock polarity = 0) | $t_{c(SPC)S} - 6 - t_r$            |                                    | ns   |
|                 | $t_{v(SPCL-SOMI)S}$ Valid time, SPInSOMI data valid after SPInCLK low (clock polarity = 1)  | $t_{c(SPC)S} - 6 - t_f$            |                                    |      |
| 6 <sup>  </sup> | $t_{su(SIMO-SPCL)S}$ Setup time, SPInSIMO before SPInCLK low (clock polarity = 0)           | 6                                  |                                    | ns   |
|                 | $t_{su(SIMO-SPCH)S}$ Setup time, SPInSIMO before SPInCLK high (clock polarity = 1)          | 6                                  |                                    |      |
| 7 <sup>  </sup> | $t_{v(SPCL-SIMO)S}$ Valid time, SPInSIMO data valid after SPInCLK low (clock polarity = 0)  | 6                                  |                                    | ns   |
|                 | $t_{v(SPCH-SIMO)S}$ Valid time, SPInSIMO data valid after SPInCLK high (clock polarity = 1) | 6                                  |                                    |      |

<sup>†</sup> The MASTER bit (SPInCTRL2.3) is cleared and the CLOCK PHASE bit (SPInCTRL2.0) is cleared.

<sup>‡</sup> If the SPI is in slave mode, the following must be true:  $t_{c(SPC)S} \geq (PS + 1)t_{c(ICLK)}$ , where PS = prescale value set in SPInCTL1.[12:5].

<sup>§</sup> For rise and fall timings, see the "switching characteristics for output timings versus load capacitance" table.

<sup>¶</sup>  $t_{c(ICLK)}$  = interface clock cycle time =  $1/f_{(ICLK)}$

<sup>#</sup> When the SPIn is in Slave mode, the following must be true:

For PS values from 1 to 255:  $t_{c(SPC)S} \geq (PS + 1)t_{c(ICLK)} \geq 100$  ns, where PS is the prescale value set in the SPInCTL1.[12:5] register bits.

For PS values of 0:  $t_{c(SPC)S} = 2t_{c(ICLK)} \geq 100$  ns.

<sup>||</sup> The active edge of the SPInCLK signal referenced is controlled by the CLOCK POLARITY bit (SPInCTRL2.1).

SPI slave mode timing parameters (continued)

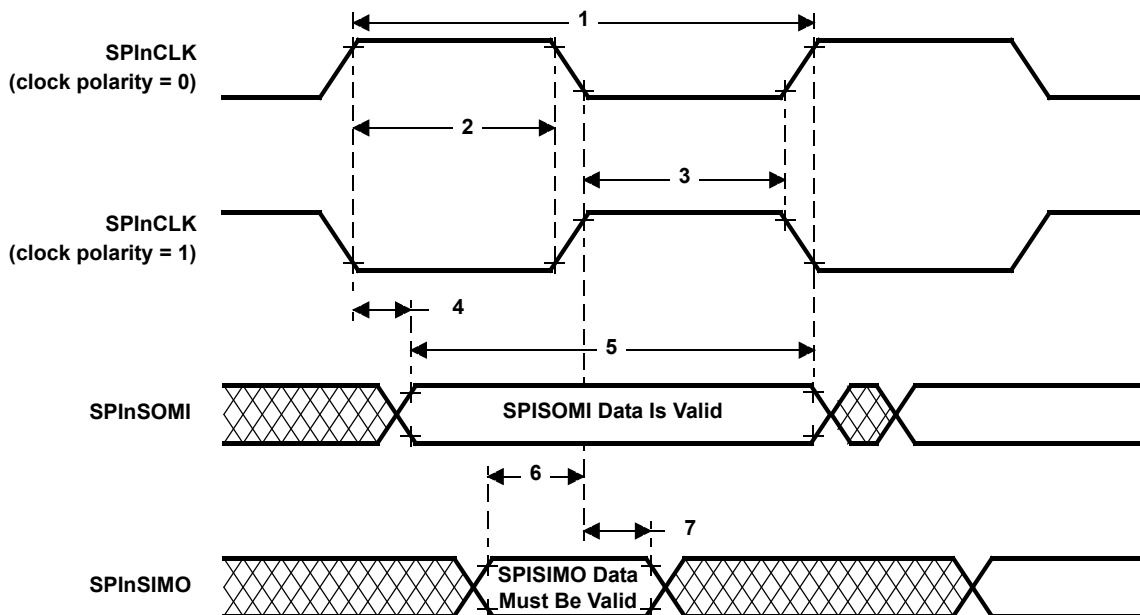

Figure 13. SPI Slave Mode External Timing (CLOCK PHASE = 0)

# TMS470R1VC336, TMS470R1VC346 16/32-BIT RISC ROM MICROCONTROLLERS

SPNS084E – MAY 2003 – REVISED AUGUST 2006

## SPIn slave mode timing parameters (continued)

SPIn slave mode external timing parameters (CLOCK PHASE = 1, SPInCLK = input, SPInSIMO = input, and SPInSOMI = output)<sup>†‡§¶</sup> (see Figure 14)

| NO.             |   | MIN                                | MAX                                | UNIT |
|-----------------|---|------------------------------------|------------------------------------|------|
| 1               | $t_{c(SPC)S}$ Cycle time, SPInCLK <sup>#</sup>  | 100                                | $256t_{c(I)CLK}$                   | ns   |
| 2 <sup>  </sup> | $t_{w(SPCH)S}$ Pulse duration, SPInCLK high (clock polarity = 0)                            | $0.5t_{c(SPC)S} - 0.25t_{c(I)CLK}$ | $0.5t_{c(SPC)S} + 0.25t_{c(I)CLK}$ | ns   |
|                 | $t_{w(SPCL)S}$ Pulse duration, SPInCLK low (clock polarity = 1)                             | $0.5t_{c(SPC)S} - 0.25t_{c(I)CLK}$ | $0.5t_{c(SPC)S} + 0.25t_{c(I)CLK}$ |      |
| 3 <sup>  </sup> | $t_{w(SPCL)S}$ Pulse duration, SPInCLK low (clock polarity = 0)                             | $0.5t_{c(SPC)S} - 0.25t_{c(I)CLK}$ | $0.5t_{c(SPC)S} + 0.25t_{c(I)CLK}$ | ns   |
|                 | $t_{w(SPCH)S}$ Pulse duration, SPInCLK high (clock polarity = 1)                            | $0.5t_{c(SPC)S} - 0.25t_{c(I)CLK}$ | $0.5t_{c(SPC)S} + 0.25t_{c(I)CLK}$ |      |
| 4 <sup>  </sup> | $t_{v(SOMI-SPCH)S}$ Valid time, SPInCLK high after SPInSOMI data valid (clock polarity = 0) | $0.5t_{c(SPC)S} - 6 - t_r$         |                                    | ns   |
|                 | $t_{v(SOMI-SPCL)S}$ Valid time, SPInCLK low after SPInSOMI data valid (clock polarity = 1)  | $0.5t_{c(SPC)S} - 6 - t_f$         |                                    |      |
| 5 <sup>  </sup> | $t_{v(SPCH-SOMI)S}$ Valid time, SPInSOMI data valid after SPInCLK high (clock polarity = 0) | $0.5t_{c(SPC)S} - 6 - t_r$         |                                    | ns   |
|                 | $t_{v(SPCL-SOMI)S}$ Valid time, SPInSOMI data valid after SPInCLK low (clock polarity = 1)  | $0.5t_{c(SPC)S} - 6 - t_f$         |                                    |      |
| 6 <sup>  </sup> | $t_{su(SIMO-SPCH)S}$ Setup time, SPInSIMO before SPInCLK high (clock polarity = 0)          | 6                                  |                                    | ns   |
|                 | $t_{su(SIMO-SPCL)S}$ Setup time, SPInSIMO before SPInCLK low (clock polarity = 1)           | 6                                  |                                    |      |
| 7 <sup>  </sup> | $t_{v(SPCH-SIMO)S}$ Valid time, SPInSIMO data valid after SPInCLK high (clock polarity = 0) | 6                                  |                                    | ns   |
|                 | $t_{v(SPCL-SIMO)S}$ Valid time, SPInSIMO data valid after SPInCLK low (clock polarity = 1)  | 6                                  |                                    |      |

<sup>†</sup> The MASTER bit (SPInCTRL2.3) is cleared and the CLOCK PHASE bit (SPInCTRL2.0) is set.

<sup>‡</sup> If the SPI is in slave mode, the following must be true:  $t_{c(SPC)S} \geq (PS + 1)t_{c(I)CLK}$ , where PS = prescale value set in SPInCTL1.[12:5].

<sup>§</sup> For rise and fall timings, see the "switching characteristics for output timings versus load capacitance" table.

<sup>¶</sup>  $t_{c(I)CLK}$  = interface clock cycle time =  $1/f_{(I)CLK}$

<sup>#</sup> When the SPIn is in Slave mode, the following must be true:

For PS values from 1 to 255:  $t_{c(SPC)S} \geq (PS + 1)t_{c(I)CLK} \geq 100$  ns, where PS is the prescale value set in the SPInCTL1.[12:5] register bits.

For PS values of 0:  $t_{c(SPC)S} = 2t_{c(I)CLK} \geq 100$  ns.

<sup>||</sup> The active edge of the SPInCLK signal referenced is controlled by the CLOCK POLARITY bit (SPInCTRL2.1).

SPIn slave mode timing parameters (continued)

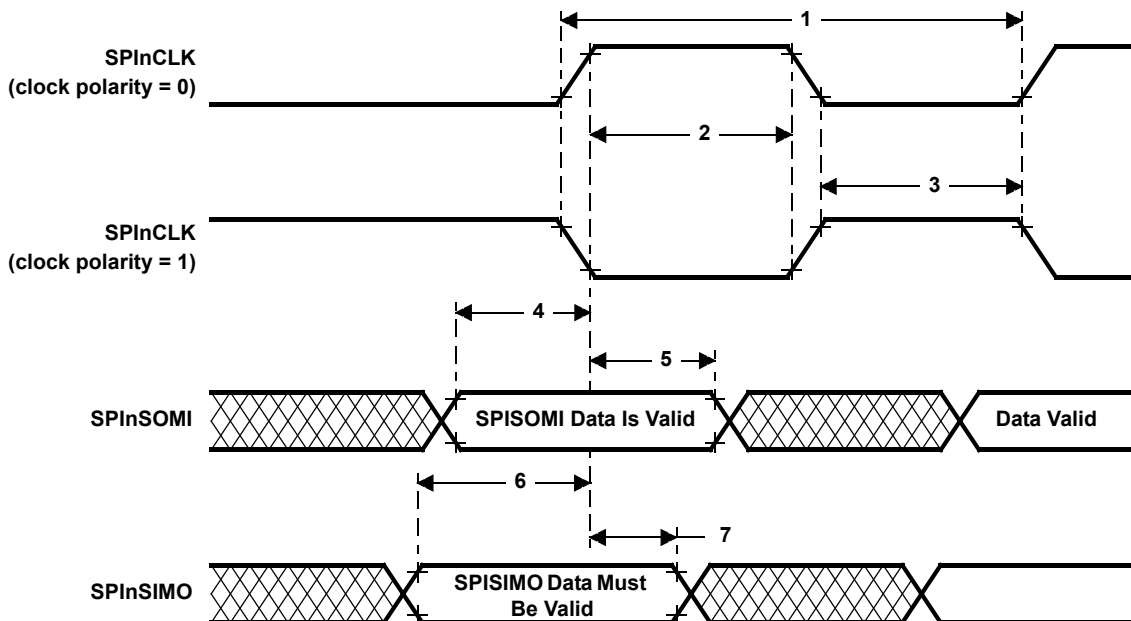

Figure 14. SPIn Slave Mode External Timing (CLOCK PHASE = 1)

# TMS470R1VC336, TMS470R1VC346 16/32-BIT RISC ROM MICROCONTROLLERS

SPNS084E – MAY 2003 – REVISED AUGUST 2006

## SCIn isosynchronous mode timings — internal clock

timing requirements for internal clock SCIn isosynchronous mode<sup>†‡§</sup> (see Figure 15)

| NO. |  | (BAUD + 1)<br>IS EVEN OR BAUD = 0 |                     | (BAUD + 1)<br>IS ODD AND BAUD ≠ 0      |                                  | UNIT |
|-----|--|-----------------------------------|---------------------|--|----------------------------------|------|
|     |  | MIN                               | MAX                 | MIN                                    | MAX                              |      |
| 1   | $t_{c(SCC)}$ Cycle time, SCInCLK                         | $2t_{c(ICLK)}$                    | $2^{24}t_{c(ICLK)}$ | $3t_{c(ICLK)}$                         | $(2^{24} - 1)t_{c(ICLK)}$        | ns   |
| 2   | $t_{w(SCCL)}$ Pulse duration, SCInCLK low                | $0.5t_{c(SCC)} - t_f$             | $0.5t_{c(SCC)} + 5$ | $0.5t_{c(SCC)} + 0.5t_{c(ICLK)} - t_f$ | $0.5t_{c(SCC)} + 0.5t_{c(ICLK)}$ | ns   |
| 3   | $t_{w(SCCH)}$ Pulse duration, SCInCLK high               | $0.5t_{c(SCC)} - t_f$             | $0.5t_{c(SCC)} + 5$ | $0.5t_{c(SCC)} - 0.5t_{c(ICLK)} - t_f$ | $0.5t_{c(SCC)} - 0.5t_{c(ICLK)}$ | ns   |
| 4   | $t_d(SCCH-TXV)$ Delay time, SCInCLK high to SCInTX valid |                                   | 10                  |  | 10                               | ns   |
| 5   | $t_v(TX)$ Valid time, SCInTX data after SCInCLK low      | $t_{c(SCC)} - 10$                 |                     | $t_{c(SCC)} - 10$                      |                                  | ns   |
| 6   | $t_{su}(RX-SCCL)$ Setup time, SCInRX before SCInCLK low  | $t_{c(ICLK)} + t_f + 20$          |                     | $t_{c(ICLK)} + t_f + 20$               |                                  | ns   |
| 7   | $t_v(SCCL-RX)$ Valid time, SCInRX data after SCInCLK low | $-t_{c(ICLK)} + t_f + 20$         |                     | $-t_{c(ICLK)} + t_f + 20$              |                                  | ns   |

† BAUD = 24-bit concatenated value formed by the SCI[H,M,L]BAUD registers.

‡  $t_{c(ICLK)}$  = interface clock cycle time =  $1/f_{(ICLK)}$

§ For rise and fall timings, see the "switching characteristics for output timings versus load capacitance" table.

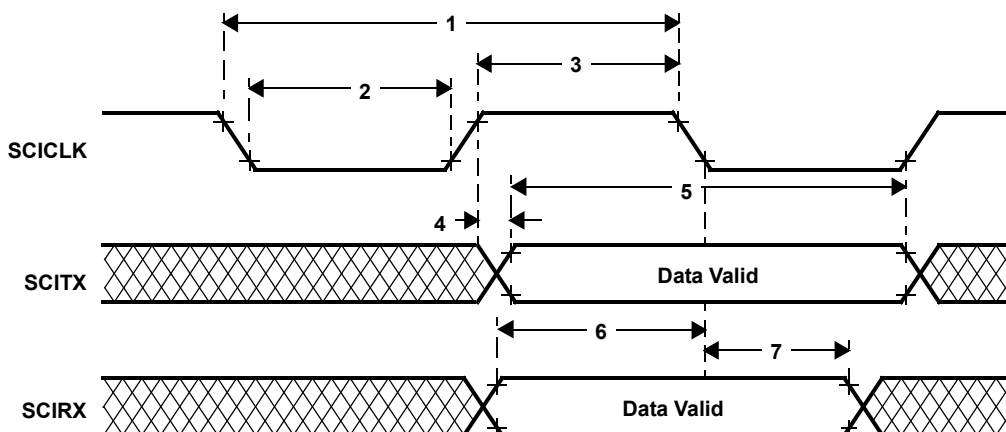

NOTE A: Data transmission/reception characteristics for isosynchronous mode with internal clocking are similar to the asynchronous mode. Data transmission occurs on the SCICLK rising edge, and data reception on the SCICLK falling edge.

Figure 15. SCIn Isosynchronous Mode Timing Diagram for Internal Clock

SCIn isosynchronous mode timings — external clock

timing requirements for external clock SCIn isosynchronous mode<sup>†‡</sup> (see Figure 16)

| NO. |  | MIN                               | MAX                               | UNIT |
|-----|--|-----------------------------------|-----------------------------------|------|
| 1   | $t_{c(SCC)}$ Cycle time, SCInCLK <sup>§</sup>              | $8t_{c(ICLK)}$                    |                                   | ns   |
| 2   | $t_{w(SCCH)}$ Pulse duration, SCInCLK high                 | $0.5t_{c(SCC)} - 0.25t_{c(ICLK)}$ | $0.5t_{c(SCC)} + 0.25t_{c(ICLK)}$ | ns   |
| 3   | $t_{w(SCCL)}$ Pulse duration, SCInCLK low                  | $0.5t_{c(SCC)} - 0.25t_{c(ICLK)}$ | $0.5t_{c(SCC)} + 0.25t_{c(ICLK)}$ | ns   |
| 4   | $t_{d(SCCH-TXV)}$ Delay time, SCInCLK high to SCInTX valid |                                   | $2t_{c(ICLK)} + 12 + t_r$         | ns   |
| 5   | $t_{v(TX)}$ Valid time, SCInTX data after SCInCLK low      | $2t_{c(SCC)} - 10$                |                                   | ns   |
| 6   | $t_{su(RX-SCCL)}$ Setup time, SCInRX before SCInCLK low    | 0                                 |                                   | ns   |
| 7   | $t_{v(SCCL-RX)}$ Valid time, SCInRX data after SCInCLK low | $2t_{c(ICLK)} + 10$               |                                   | ns   |

<sup>†</sup>  $t_{c(ICLK)}$  = interface clock cycle time =  $1/f_{(ICLK)}$

<sup>‡</sup> For rise and fall timings, see the "switching characteristics for output timings versus load capacitance" table.

<sup>§</sup> When driving an external SCInCLK, the following must be true:  $t_{c(SCC)} \geq 8t_{c(ICLK)}$

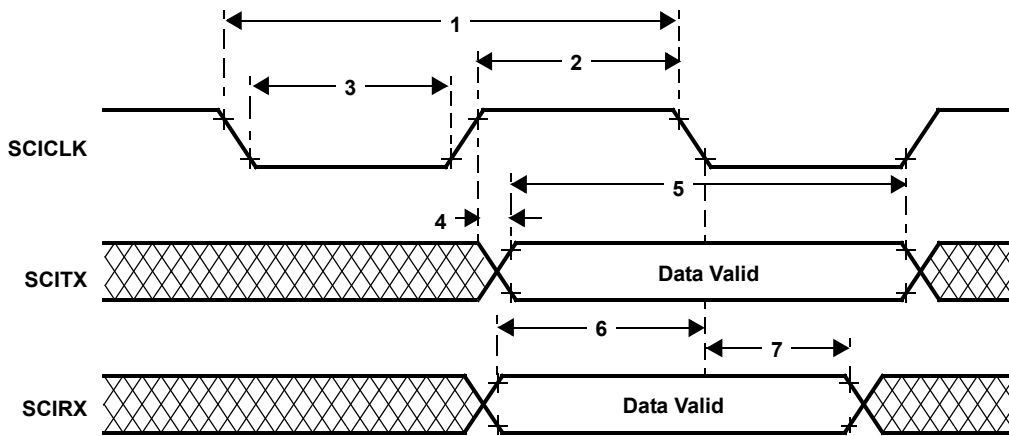

NOTE A: Data transmission/reception characteristics for isosynchronous mode with external clocking are similar to the asynchronous mode. Data transmission occurs on the SCICLK rising edge, and data reception on the SCICLK falling edge.

Figure 16. SCIn Isosynchronous Mode Timing Diagram for External Clock

# TMS470R1VC336, TMS470R1VC346 16/32-BIT RISC ROM MICROCONTROLLERS

SPNS084E – MAY 2003 – REVISED AUGUST 2006

---

## high-end timer (HET) timings

### minimum PWM output pulse width:

This is equal to one High Resolution Clock Period (HRP). The HRP is defined by the 6-bit High Resolution Prescale Factor (hr) which is user defined, giving prescale factors of 1 to 64, with a linear increment of codes.

Therefore, the minimum PWM output pulse width =  $HRP(\min) = hr(\min)/SYSCLK = 1/SYSCLK$

For example, for a SYSCLK of 30 MHz, the minimum PWM output pulse width =  $1/30 = 33.33\text{ns}$

### minimum input pulses we can capture:

The input pulse width must be greater or equal to the Low Resolution Clock Period (LRP), i.e., the HET loop (the HET program must fit within the LRP). The LRP is defined by the 3-bit Loop-Resolution Prescale Factor (lr), which is user defined, with a power of 2 increment of codes. That is, the value of lr can be 1, 2, 4, 8, 16, or 32.

Therefore, the minimum input pulse width =  $LRP(\min) = hr(\min) * lr(\min)/SYSCLK = 1 * 1/SYSCLK$

For example, with a SYSCLK of 30 MHz, the minimum input pulse width =  $1 * 1/30 = 33.33 \text{ ns}$

**Note:** Once the input pulse width is greater than LRP, the resolution of the measurement is still HRP. (That is, the captured value gives the number of HRP clocks inside the pulse.)

Abbreviations:

High resolution clock period =  $HRP = hr/SYSCLK$

Loop resolution clock period =  $LRP = hr*lr/SYSCLK$

hr = HET high resolution divide rate = 1, 2, 3,...63, 64

lr = HET low resolution divide rate = 1, 2, 4, 8, 16, 32



# TMS470R1VC336, TMS470R1VC346 16/32-BIT RISC ROM MICROCONTROLLERS

SPNS084E – MAY 2003 – REVISED AUGUST 2006

## standard CAN controller (SCC) mode timings

### dynamic characteristics for the CANSTX and CANSRX pins

| PARAMETER            |  | MIN | MAX | UNIT |
|----------------------|--|-----|-----|------|
| $t_d(\text{CANSTX})$ | Delay time, transmit shift register to CANSTX pin <sup>†</sup> |     | 15  | ns   |
| $t_d(\text{CANSRX})$ | Delay time, CANSRX pin to receive shift register               |     | 5   | ns   |

<sup>†</sup> These values do not include rise/fall times of the output buffer.

# TMS470R1VC336, TMS470R1VC346 16/32-BIT RISC ROM MICROCONTROLLERS

SPNS084E – MAY 2003 – REVISED AUGUST 2006

## multi-buffered A-to-D converter (MibADC)

The multi-buffered A-to-D converter (MibADC) has a separate power bus for its analog circuitry that enhances the A-to-D performance by preventing digital switching noise on the logic circuitry which could be present on  $V_{SS}$  and  $V_{CC}$  from coupling into the A-to-D analog stage. All A-to-D specifications are given with respect to  $AD_{REFLO}$  unless otherwise noted.

Resolution . . . . . 10 bits (1024 values)  
 Monotonic . . . . . Assured  
 Output conversion code . . . . . 00h to 3FFh [00 for  $V_{AI} \leq AD_{REFLO}$ ; 3FF for  $V_{AI} \geq AD_{REFHI}$ ]

## MibADC recommended operating conditions<sup>†</sup>

|              |   | MIN              | MAX              | UNIT |
|--------------|---|------------------|------------------|------|
| $AD_{REFHI}$ | A-to-D high -voltage reference source   | $V_{SSAD}$       | $V_{CCAD}$       | V    |
| $AD_{REFLO}$ | A-to-D low-voltage reference source   | $V_{SSAD}$       | $V_{CCAD}$       | V    |
| $V_{AI}$     | Analog input voltage  | $V_{SSAD} - 0.3$ | $V_{CCAD} + 0.3$ | V    |
| $I_{AIC}$    | Analog input clamp current <sup>‡</sup><br>( $V_{AI} < V_{SSAD} - 0.3$ or $V_{AI} > V_{CCAD} + 0.3$ ) | - 2              | 2                | mA   |

<sup>†</sup> For  $V_{CCAD}$  and  $V_{SSAD}$  recommended operating conditions, see the "device recommended operating conditions" table.

<sup>‡</sup> Input currents into any ADC input channel outside the specified limits could affect conversion results of other channels.

## operating characteristics over full ranges of recommended operating conditions<sup>§¶</sup>

| PARAMETER     | DESCRIPTION/CONDITIONS                                       | MIN  | TYP | MAX        | UNIT |          |     |
|---------------|--|--|-----|------------|------|----------|-----|
| $R_i$         | Analog input resistance                                      | See Figure 17  |     | 250        | 500  | $\Omega$ |     |
| $C_i$         | Analog input capacitance                                     | See Figure 17  |     | Conversion |      | 10       | pF  |
|               |  |  |     | Sampling   |      | 30       | pF  |
| $I_{AIL}$     | Analog input leakage current                                 | See Figure 17  |     | -250       | 250  | nA       |     |
| $I_{ADREFHI}$ | $AD_{REFHI}$ input current                                   | $AD_{REFHI} = 3.6$ V, $AD_{REFLO} = V_{SSAD}$  |     |            |      | 5        | mA  |
| CR            | Conversion range over which specified accuracy is maintained | $AD_{REFHI} - AD_{REFLO}$  |     | 3          | 3.6  | V        |     |
| $E_{DNL}$     | Differential nonlinearity error                              | Difference between the actual step width and the ideal value after offset correction. (See Figure 18)  |     |            |      | $\pm 2$  | LSB |
| $E_{INL}$     | Integral nonlinearity error                                  | Maximum deviation from the best straight line through the MibADC. MibADC transfer characteristics, excluding the quantization error after offset correction. (See Figure 19) |     |            |      | $\pm 2$  | LSB |
| $E_{TOT}$     | Total error/Absolute accuracy                                | Maximum value of the difference between an analog value and the ideal midstep value. (See Figure 20)   |     |            |      | $\pm 2$  | LSB |

<sup>§</sup>  $V_{CCAD} = AD_{REFHI}$

<sup>¶</sup> 1 LSB =  $(AD_{REFHI} - AD_{REFLO})/2^{10}$  for the MibADC

multi-buffered A-to-D converter (MibADC) (continued)

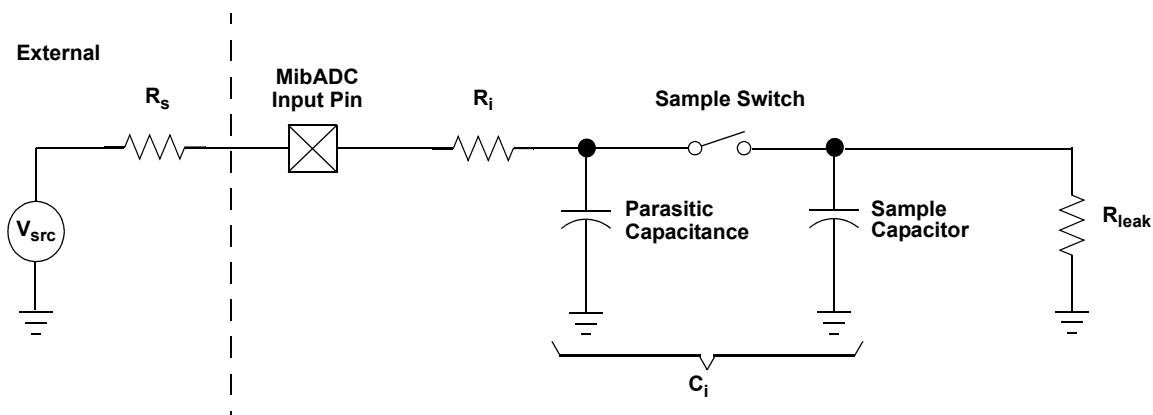

Figure 17. MibADC Input Equivalent Circuit

multi-buffer ADC timing requirements

|                    |   | MIN  | NOM | MAX | UNIT          |
|--------------------|---|------|-----|-----|---------------|
| $t_{c(ADCLK)}$     | Cycle time, MibADC clock                          | 0.05 |     |     | $\mu\text{s}$ |
| $t_{d(SH)}$        | Delay time, sample and hold time                  | 1    |     |     | $\mu\text{s}$ |
| $t_{d(C)}$         | Delay time, conversion time                       | 0.55 |     |     | $\mu\text{s}$ |
| $t_{d(SHC)}^{(1)}$ | Delay time, total sample/hold and conversion time | 1.55 |     |     | $\mu\text{s}$ |

† This is the minimum sample/hold and conversion time that can be achieved. These parameters are dependent on many factors; for more details, see the *TMS470R1x Multi-Buffered Analog-to-Digital (MibADC) Reference Guide* (literature number SPNU206).

# TMS470R1VC336, TMS470R1VC346 16/32-BIT RISC ROM MICROCONTROLLERS

SPNS084E – MAY 2003 – REVISED AUGUST 2006

## multi-buffered A-to-D converter (MibADC) (continued)

The differential nonlinearity error shown in Figure 18 (sometimes referred to as differential linearity) is the difference between an actual step width and the ideal value of 1 LSB.

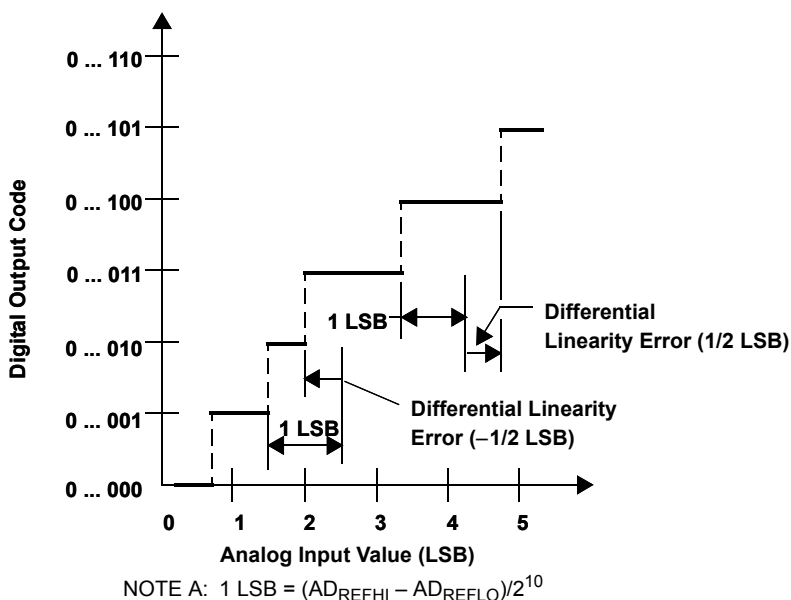

Figure 18. Differential Nonlinearity (DNL)

The integral nonlinearity error shown in Figure 19 (sometimes referred to as linearity error) is the deviation of the values on the actual transfer function from a straight line.

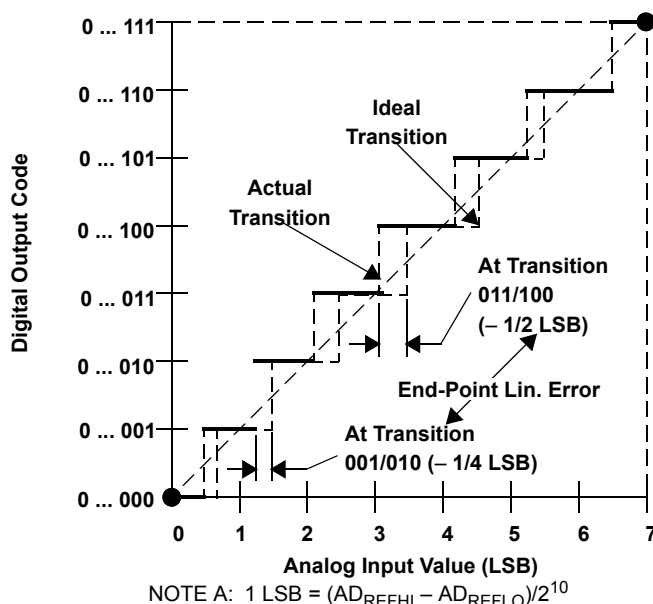

Figure 19. Integral Nonlinearity (INL) Error

multi-buffer A-to-D converter (MibADC) (continued)

The absolute accuracy or total error of an MibADC as shown in Figure 20 is the maximum value of the difference between an analog value and the ideal midstep value.

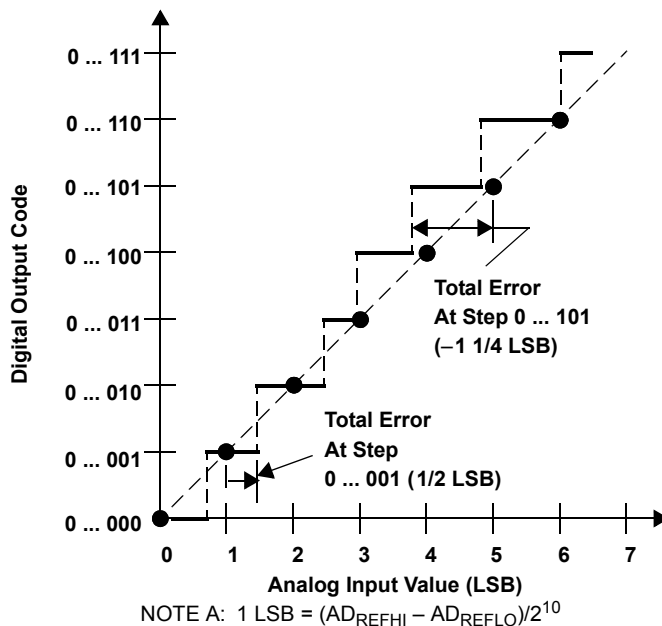

Figure 20. Absolute Accuracy (Total) Error

# TMS470R1VC336, TMS470R1VC346 16/32-BIT RISC ROM MICROCONTROLLERS

SPNS084E – MAY 2003 – REVISED AUGUST 2006

## MECHANICAL DATA

PZ (S-PQFP-G100)

PLASTIC QUAD FLATPACK

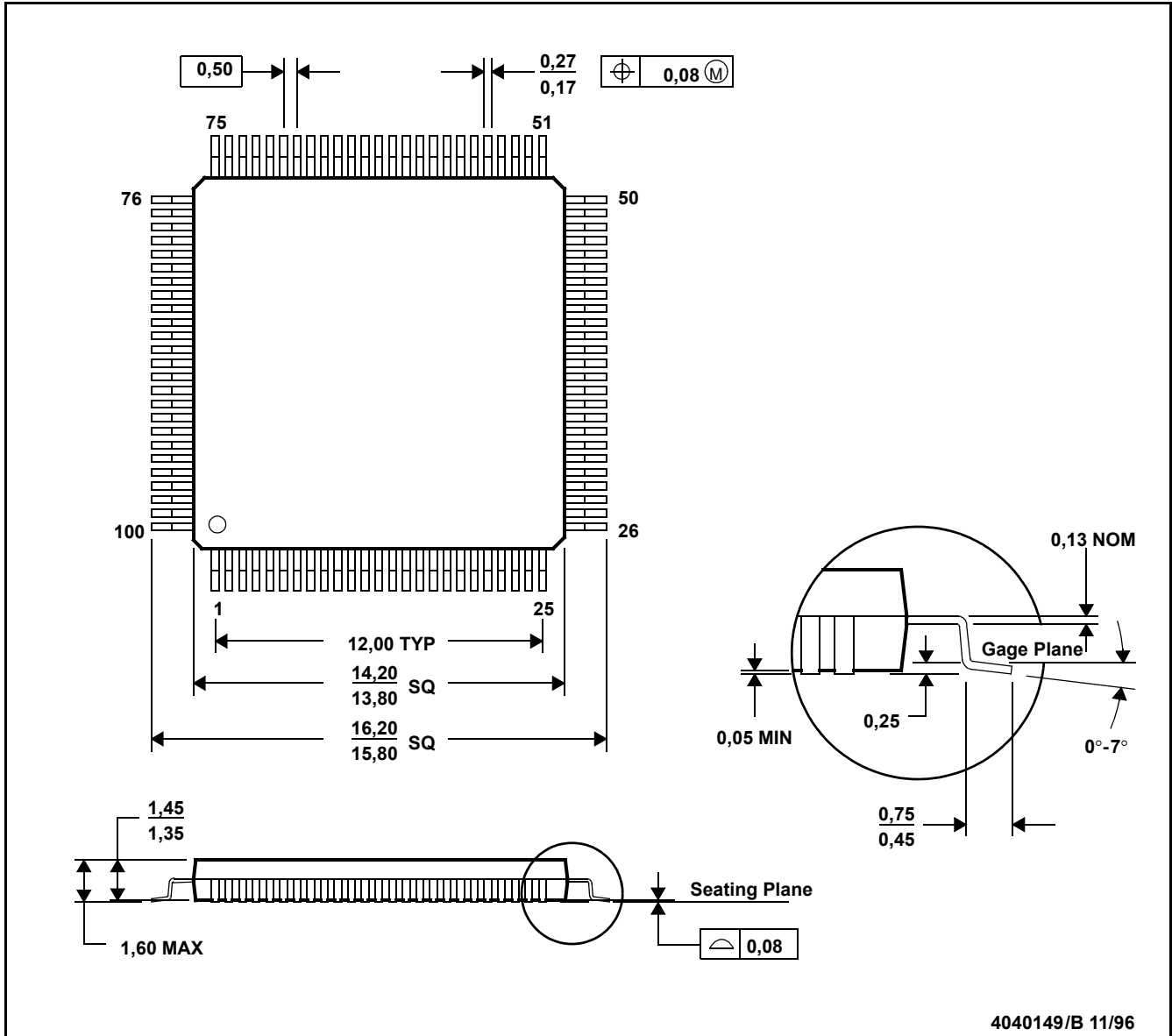

- NOTES: A. All linear dimensions are in millimeters.  
 B. This drawing is subject to change without notice.  
 C. Falls within JEDEC MS-026.

### Thermal Resistance Characteristics

| PARAMETER       | °C/W |
|-----------------|------|
| $R_{\theta JA}$ | 51   |
| $R_{\theta JC}$ | 5    |

## List of Figures

[TMS470R1VC336 100-Pin PZ Package \(TOP VIEW\)](#)

[TMS470R1VC346 100-Pin PZ Package \(TOP VIEW\)](#)

[Functional Block Diagram](#)

[Figure 1. Memory Map](#)

[Figure 2. TMS470R1x Family Nomenclature](#)

[Figure 3. Test Load Circuit](#)

[Figure 4. Crystal/Clock Connection](#)

[Figure 5. CLKOUT Timing Diagram](#)

[Figure 6. ECLK Timing Diagram](#)

[Figure 7. PORRST Timing Diagram](#)

[Figure 8. JTAG Scan Timing](#)

[Figure 9. CMOS-Level Outputs](#)

[Figure 10. CMOS-Level Inputs](#)

[Figure 11. SPIn Master Mode External Timing \(CLOCK PHASE = 0\)](#)

[Figure 12. SPIn Master Mode External Timing \(CLOCK PHASE = 1\)](#)

[Figure 13. SPIn Slave Mode External Timing \(CLOCK PHASE = 0\)](#)

[Figure 14. SPIn Slave Mode External Timing \(CLOCK PHASE = 1\)](#)

[Figure 15. SCIn Isosynchronous Mode Timing Diagram for Internal Clock](#)

[Figure 16. SCIn Isosynchronous Mode Timing Diagram for External Clock](#)

[Figure 17. MibADC Input Equivalent Circuit](#)

[Figure 18. Differential Nonlinearity \(DNL\)](#)

[Figure 19. Integral Nonlinearity \(INL\) Error](#)

[Figure 20. Absolute Accuracy \(Total\) Error](#)

[Mechanical Data](#)

# TMS470R1VC336, TMS470R1VC346 16/32-BIT RISC ROM MICROCONTROLLERS

SPNS084E – MAY 2003 – REVISED AUGUST 2006

---

## List of Tables

- [Table 1. Device Characteristics](#)
- [Table 2. VC3x6 Memory Selection Assignment](#)
- [Table 3. VC3x6 Peripherals and System Module Base Addresses](#)
- [Table 4. Interrupt Priority](#)
- [Table 5. MibADC Event Hookup Configuration](#)
- [Table 6. TMS470 Device ID Bit Allocation Register](#)
- [Table 7. Device Part Number](#)



**TMS470R1VC336, TMS470R1VC346**  
**16/32-BIT RISC ROM MICROCONTROLLERS**  
**REVISION HISTORY**

---

**REVISION HISTORY**

| REV | DATE | NOTES   |
|-----|------|---|
| E   | 8/06 | Updates:<br>Throughout, VC336 system clock in non-pipeline mode changed to 28MHz<br>Page 34, timing #5 updated<br>Page 46, analog input leakage current updated |

## IMPORTANT NOTICE

Texas Instruments Incorporated and its subsidiaries (TI) reserve the right to make corrections, modifications, enhancements, improvements, and other changes to its products and services at any time and to discontinue any product or service without notice. Customers should obtain the latest relevant information before placing orders and should verify that such information is current and complete. All products are sold subject to TI's terms and conditions of sale supplied at the time of order acknowledgment.

TI warrants performance of its hardware products to the specifications applicable at the time of sale in accordance with TI's standard warranty. Testing and other quality control techniques are used to the extent TI deems necessary to support this warranty. Except where mandated by government requirements, testing of all parameters of each product is not necessarily performed.

TI assumes no liability for applications assistance or customer product design. Customers are responsible for their products and applications using TI components. To minimize the risks associated with customer products and applications, customers should provide adequate design and operating safeguards.

TI does not warrant or represent that any license, either express or implied, is granted under any TI patent right, copyright, mask work right, or other TI intellectual property right relating to any combination, machine, or process in which TI products or services are used. Information published by TI regarding third-party products or services does not constitute a license from TI to use such products or services or a warranty or endorsement thereof. Use of such information may require a license from a third party under the patents or other intellectual property of the third party, or a license from TI under the patents or other intellectual property of TI.

Reproduction of information in TI data books or data sheets is permissible only if reproduction is without alteration and is accompanied by all associated warranties, conditions, limitations, and notices. Reproduction of this information with alteration is an unfair and deceptive business practice. TI is not responsible or liable for such altered documentation.

Resale of TI products or services with statements different from or beyond the parameters stated by TI for that product or service voids all express and any implied warranties for the associated TI product or service and is an unfair and deceptive business practice. TI is not responsible or liable for any such statements.

Following are URLs where you can obtain information on other Texas Instruments products and application solutions:

### Products

|                    |  |
|--------------------|--|
| Amplifiers         | <a href="http://amplifier.ti.com">amplifier.ti.com</a>             |
| Data Converters    | <a href="http://dataconverter.ti.com">dataconverter.ti.com</a>     |
| DSP                | <a href="http://dsp.ti.com">dsp.ti.com</a>                         |
| Interface          | <a href="http://interface.ti.com">interface.ti.com</a>             |
| Logic              | <a href="http://logic.ti.com">logic.ti.com</a>                     |
| Power Mgmt         | <a href="http://power.ti.com">power.ti.com</a>                     |
| Microcontrollers   | <a href="http://microcontroller.ti.com">microcontroller.ti.com</a> |
| Low Power Wireless | <a href="http://www.ti.com/lpw">www.ti.com/lpw</a>                 |

### Applications

|                    |  |
|--------------------|--|
| Audio              | <a href="http://www.ti.com/audio">www.ti.com/audio</a>                   |
| Automotive         | <a href="http://www.ti.com/automotive">www.ti.com/automotive</a>         |
| Broadband          | <a href="http://www.ti.com/broadband">www.ti.com/broadband</a>           |
| Digital Control    | <a href="http://www.ti.com/digitalcontrol">www.ti.com/digitalcontrol</a> |
| Military           | <a href="http://www.ti.com/military">www.ti.com/military</a>             |
| Optical Networking | <a href="http://www.ti.com/opticalnetwork">www.ti.com/opticalnetwork</a> |
| Security           | <a href="http://www.ti.com/security">www.ti.com/security</a>             |
| Telephony          | <a href="http://www.ti.com/telephony">www.ti.com/telephony</a>           |
| Video & Imaging    | <a href="http://www.ti.com/video">www.ti.com/video</a>                   |
| Imaging Wireless   | <a href="http://www.ti.com/wireless">www.ti.com/wireless</a>             |

Mailing Address: Texas Instruments  
Post Office Box 655303 Dallas, Texas 75265

Copyright © 2006, Texas Instruments Incorporated

[www.BDTIC.com/TI](http://www.BDTIC.com/TI)