

MULTIFUNCTION 3-CHANNEL LED DRIVERS

Check for Samples: [TPS68401](#), [TPS68402](#)

FEATURES

- Multifunction LED Driver With Three Independent Channels
- Integrated High Efficiency 1x / 1.5x Charge Pump With Automatic or Manual Gain Change
- 3 x 25.5-mA Total Output Current
- 3 x 25.5-mA Total Output Current
- Three Independent Program Execution Engines (3 x 16 Instructions)
- 8-Bit PWM With Exponential Control Option
- 8-Bit Current DAC Control
- 200-nA Typical Shutdown Current
- Automatic Power-Save Mode
- Autonomous Operation Without External Control
- Trigger I/O for Synchronizing Multiple Devices
- One or Two General Purpose Output Controlled Via Serial Interface

- I²C Interface
- Operating Temperature Range: -30°C to 85°C
- 20-Ball WLCSP Package With 0.4-mm Pitch

APPLICATIONS

- LED Control for Portable Applications
- Accent Lighting (Mood, Personalization, etc.)
- Function Indication (Charge, Messages, etc.)
- Keypad Illumination / Backlight (White or RGB)
- Display Backlight

DESCRIPTION

The TPS68401/TPS68402 is an advanced lighting management unit for handheld devices. It has three independent channels optimized for driving RGB LEDs. The built-in fractional charge pump boosts the input voltage to power the LEDs at low input voltage. Channel one can optionally be supplied directly from the battery voltage to reduce power consumption and improve efficiency.

At the heart of the device is a programmable state machine which executes a lighting program consisting of up to 16 instructions per channel. Once the program is loaded through the I²C interface the device is fully independent from the main processor resulting in significant system-level power savings. The device can issue an interrupt to the main processor via the INT pin.

The TRIG I/O allows synchronization between multiple devices. A general-purpose output pin is provided which is addressable through the serial interface. In addition, the INT pin can also be configured as general-purpose output.



Please be aware that an important notice concerning availability, standard warranty, and use in critical applications of Texas Instruments semiconductor products and disclaimers thereto appears at the end of this data sheet.



This integrated circuit can be damaged by ESD. Texas Instruments recommends that all integrated circuits be handled with appropriate precautions. Failure to observe proper handling and installation procedures can cause damage.

ESD damage can range from subtle performance degradation to complete device failure. Precision integrated circuits may be more susceptible to damage because very small parametric changes could cause the device not to meet its published specifications.

FUNCTIONAL BLOCK DIAGRAM

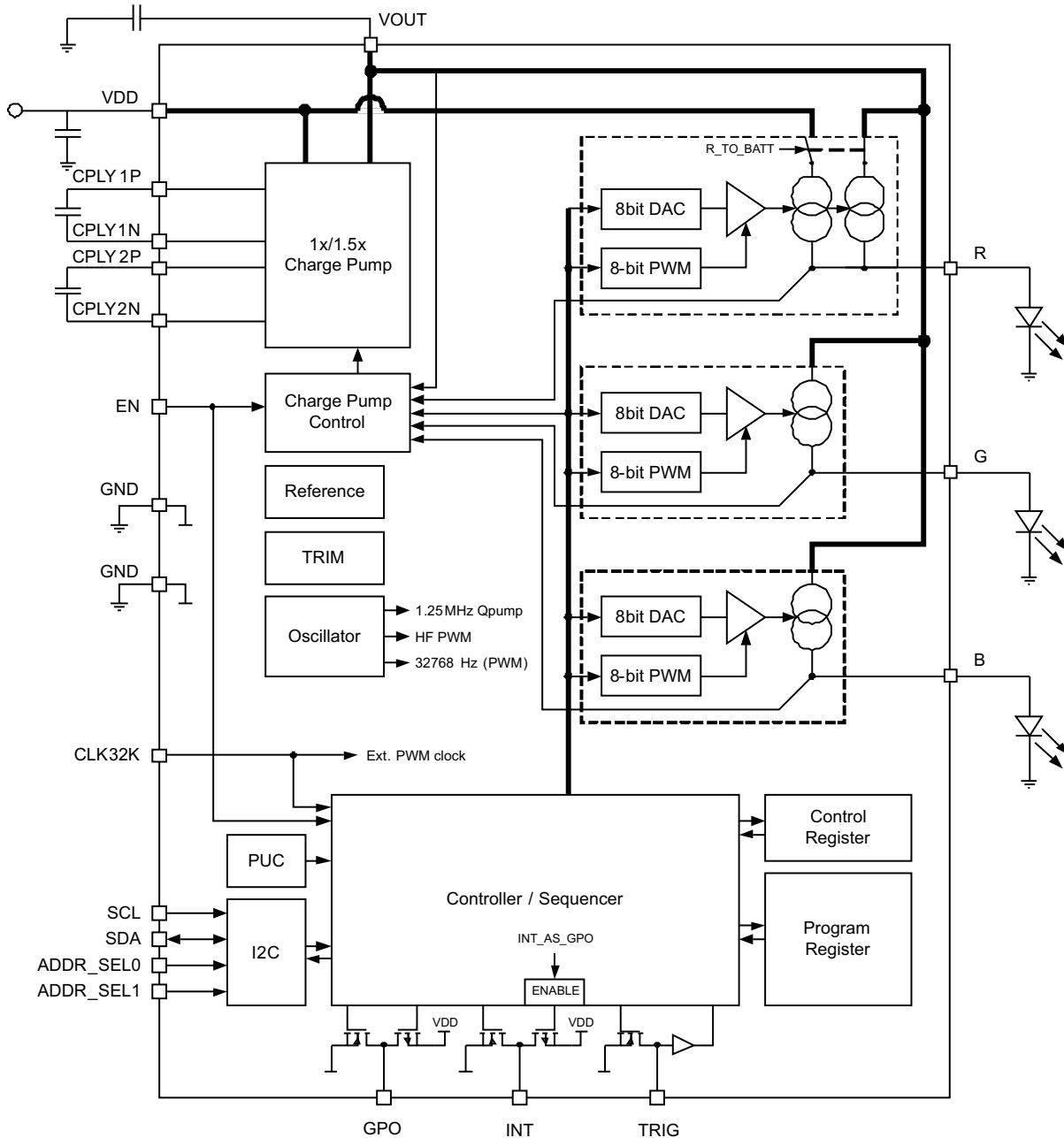

ORDERING INFORMATION

T _A	PACKAGE	ORDERABLE PART NUMBER	TOP-SIDE MARKING
-30°C to 85°C	YFF	TPS68401C4YFFR	TPS68401C4YFF
	RHF	TPS68402A0RHFR	24RHF

TERMINAL FUNCTIONS

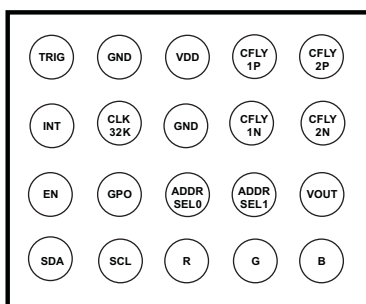
 NanoFree PACKAGE
(BOTTOM VIEW)

E D C B A

PACKAGE MARKING

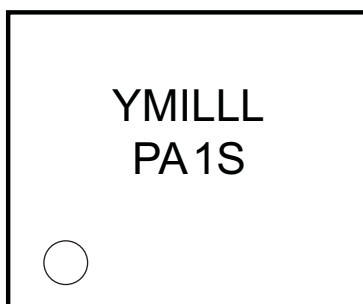

YM = YEAR / MONTH DATE CODE
 LLLL = LOT TRACE CODE
 S = ASSEMBLY SITE CODE
 A = MAJOR DIE REVISION
 1 = MINOR DIE REVISION
 P = PREPRODUCTION INDICATOR
 0 = Pin A1 (Filled Solid)

TERMINAL		I/O	DESCRIPTION
NAME	NO.		
CFLY1P	4B		Positive terminal of charge pump fly capacitor
CFLY1N	3B		Negative terminal of charge pump fly capacitor
CFLY2P	4A		Positive terminal of charge pump fly capacitor
CFLY2N	3A		Negative terminal of charge pump fly capacitor
VDD	4C		Power pin
GND	4D		Ground
VOUT	2A		Charge pump output
R	1C	O	Current source output, Channel 1 (Red)
G	1B	O	Current source output, Channel 2 (Green)
B	1A	O	Current source output, Channel 3 (Blue)
SCL	1D	I	I ² C Serial interface clock input
SDA	1E	I/O	I ² C Serial interface data input/output (open drain)
CLK32K	3D	I	32.768-kHz clock input – If no clock present on power-up or after RESET, uses internal oscillator
EN	2E	I	Chip enable (active high)
ADDR_SEL0	2C	I	I ² C address select input
ADDR_SEL1	2B	I	I ² C address select input
INT	3E	O	Interrupt output (open drain, active low); Can be configured as push-pull GPO
TRIG	4E	I/O	Trigger input / output (open drain, active low)
GPO	2D	O	General purpose output
GND	3C		Ground

ABSOLUTE MAXIMUM RATINGS

over operating free-air temperature range (unless otherwise noted) ⁽¹⁾⁽²⁾

		VALUE	UNIT
V_{OUT}	V_{DD} (unregulated input battery voltage)	-0.3 to 6	V
Input/Output voltage range (with respect to PGND)	INT, GPO, R, G, B, CFLY1N, CFLY1P, CFLY2N, CFLY2P, ADDR_SEL0, ADDR_SEL1	-0.3 to $V_{DD}+0.3$ (6.0 max)	V
	SDA, SCL, EN, TRIG, CLK32K		
θ_{JA}	Junction-to-ambient thermal resistance	100	°C/W
P_D	Continuous power dissipation	Internally limited	W
T_J	Operating junction temperature	-30 to 125	°C
T_{stg}	Storage temperature	-65 to 150	°C
ESD rating	(HBM) Human body model	±2000	V
	(CDM) Charged device model	±100	

- (1) Stresses beyond those listed under Absolute Maximum Ratings may cause permanent damage to the device. These are stress ratings only, and functional operation of the device at these or any other conditions beyond those indicated under Recommended Operating Conditions is not implied. Exposure to absolute maximum rated conditions for extended periods may affect device reliability.
- (2) All voltage values are with respect to network ground terminal.

RECOMMENDED OPERATING CONDITIONS

over operating free-air temperature range (unless otherwise noted)

		MIN	NOM	MAX	UNIT
V_{DD}	Unregulated input battery voltage	2.7	3.6	5.5	V
INT, GPO, ADDR_SEL0, ADDR_SEL1		0		5.5	V
SDA, SCL, EN, TRIG		0		1.8	V
CLK_32K	External clock frequency	16	32	64	kHz
T_A	Operating ambient temperature	-30		85	°C
	Flying capacitor		0.47		µF
	Input capacitor (V_{DD})		1		µF
	Output capacitor (V_{OUT})		1		µF
	SCA, SDA pull-up resistor value		10		kΩ
	INT pull-up resistor value		10		kΩ

ELECTRICAL CHARACTERISTICS
 $V_{BAT} = 3.6\text{ V} \pm 5\%$, $T_A = 25^\circ\text{C}$ (unless otherwise noted)

PARAMETER		TEST CONDITIONS	MIN	TYP	MAX	UNIT
SUPPLY CURRENT						
I_{DD}	Shutdown current	EN = 0		0.2	2.0	μA
	Standby current	EN = 1; CHIP_EN = 0 Ext. 32-kHz clock not running		1	2.0	μA
		EN = 1; CHIP_EN = 0 Ext. 32-kHz clock running		1	2.0	
	Normal mode supply current	EN = 1, CHIP_EN = 1 Ext. 32-kHz clock running C/P, G & B channel disabled R_TO_BATT = 1 (R channel enabled) [CLK_DET_EN : INT_CLK_EN] = 00b (clock detection disabled) $I_{LED} = 5\text{ mA}$, 50% duty cycle			180	μA
		EN = 1, CHIP_EN = 1 C/P and LED drivers disabled [CLK_DET_EN : INT_CLK_EN] = 10b (automatic clock source selection) PWRSAVE_EN = 0			190	
		EN = 1, CHIP_EN = 1 C/P in 1x mode, no load ⁽¹⁾ , LED drivers disabled Ext. 32-kHz clock running			70	
		EN = 1, CHIP_EN = 1 C/P in 1.5x mode, no load ⁽¹⁾ , LED drivers disabled			1700	
		EN = 1, CHIP_EN = 1 C/P in 1x mode, no load ⁽¹⁾ , LED drivers enabled Ext. 32-kHz clock running			650	
	Power save current	EN = 1, CHIP_EN = 1 CLK32K active			10	μA
		EN = 1, CHIP_EN = 1 Internal oscillator running			190	
STARTUP						
$t_{STARTUP}$	Startup time	STANDBY to NORMAL mode		500	1000	μs
BOOST VOLTAGE (V_{OUT})						
V_{OUT}	Output voltage	1x mode, no load ⁽¹⁾		V_{DD}		V
		1.5x mode, $V_{DD} = 3.6\text{ V}$, no load ⁽¹⁾		4.55		
V_{HYS}	Automatic gain change hysteresis	C/P in automatic mode, no load ⁽¹⁾		200		mV
I_{OUT}	Continuous output current			150		mA
	Max output current	$V_{OUT} < 1\text{ V}$		150		
		$V_{OUT} > 1\text{ V}$	150	250		
f_S	Switching frequency			1.25		MHz
Z_O	Open loop output impedance	1x mode $(V_{DD} - V_{OUT}) / I_{OUT}$		1.1		Ω
		1.5x mode ⁽²⁾		4.1		
t_{ON}	Turn on time from 1x to 1.5x mode.	$V_{DD} = 3.6\text{ V}$		50		μs
	Turn on time from off to 1.5x mode.	$V_{OUT} = 0\text{ V}$		100		

(1) No-load measurement condition is as follows: DAC setting = default (17.5 mA); PWM = 0; Output connected to ground via 150- Ω resistor.

(2) Charge pump Impedance is measured at $V_{DD} = 3\text{ V}$, $I_{OUT} = 50\text{ mA}$ follows: $[V_{OUT}(I_{OUT} = 0) - V_{OUT}(I_{OUT})] / I_{OUT}$

ELECTRICAL CHARACTERISTICS (continued)

V_{BAT} = 3.6 V ±5%, T_A = 25°C (unless otherwise noted)

PARAMETER		TEST CONDITIONS	MIN	TYP	MAX	UNIT
INTERNAL OSCILLATOR						
f _{OSC}	Internal oscillator frequency	T _A = 25 °C	-4		4	%
		-30 °C ≤ T _A ≤ 85 °C	-7		7	
OUTPUT CHANNELS (R,G,B)						
V _{LED}	LED forward voltage		1.5			
V _{DRP}	Driver saturation voltage	I _{R,G,B} = 17.5 mA ⁽³⁾		50	100	mV
I _{R,G,B}	LED current	Per channel	0		25.5	mA
	LED current resolution			8		Bit
	LED current accuracy	I _{R,G,B} = 17.5 mA	-4		4	%
	LED current matching	I _{R,G,B} = 17.5 mA, V _f = 3.0 V		1	2	%
f _{PWM}	PWM frequency	PWM_HF = 1 Internal high frequency oscillator		558		Hz
		PWM_HF = 0 Internal clock or CLK_32K		256		
I _{LEAK}	Pin leakage current	T _A = 25 °C		0.1		μA
		-30 °C ≤ T _A ≤ 85 °C			1	
PWM _{RES}	PWM resolution		8			Bit
LOGIC INPUT LEVELS (EN)						
V _{IL}	Input low level				0.5	V
V _{IH}	Input high level		1.2			V
I _{IH} , I _{IL}	Input bias current	V _{EN} = 0 V to 1.65 V	-1		1	μA
t _{delay}	Input delay	EN pin low to high		2		μs
LOGIC INPUT LEVELS (SCL, SDA, TRIG, CLK_32K)						
V _{IL}	Input low level	V _{EN} = 1.65 V to 3.6 V		0.2 x V _{EN}		V
V _{IH}	Input high level	V _{EN} = 1.65V to 3.6 V	0.8 x V _{EN}			V
I _{IH} , I _{IL}	Input bias current		-1.0		1.0	μA
f _{SCL}	I ² C clock frequency				400	kHz
LOGIC INPUT LEVELS (ADD_SEL0, ADD_SEL1)						
V _{IL}	Input low level			0.2 x V _{DD}		V
V _{IH}	Input high level		0.8 x V _{DD}			V
I _{IH} , I _{IL}	Input bias current	V _{ADD_SEL0} , _{ADD_SEL1} = 3.6 V	-1.0		1.0	μA
LOGIC OUTPUT LEVELS (SDA, TRIG, INT pin as INT)						
V _{OL}	Output low level	I _{OUT} = 3 mA through pull-up		0.3	0.5	V
I _{IL}	Output leakage current	INT pin as INT (open drain), INT = high, V _{INT} = 0 V to 1.65 V			1.0	μA
LOGIC OUTPUT LEVELS (GPO, INT pin as GPO)						
V _{OL}	Output low level	I _{OUT} = 3 mA		0.3	0.5	V
V _{OH}	Output high level	I _{OUT} = -2 mA	V _{DD} - 0.5	V _{DD} - 0.3		V

(3) I_{OUT} at V_{DRP} = 0.9 x I_{OUT} at (V_{DD} - V_{LED}) = 1 V

DESCRIPTION OF CHARGE PUMP OPERATION

The TPS68401/TPS68402 includes a regulated fractional charge pump with bypass mode. It is used to boost the supply voltage for the output drivers when the battery voltage is close to or below the forward bias voltage of the LEDs. In 1.5x mode V_{OUT} is boosted to $1.5x V_{DD}$ or 4.55 V, whichever value is lower. In 1x (bypass) mode the output is connected directly to the input supply.

The charge pump is controlled with two CP_MODE bits in the CONFIG register. When disabled, V_{OUT} is connected to ground through a 300-k Ω resistive path. The user can manually select 1x and 1.5x mode or select automatic mode. When automatic mode is enabled, the charge pump will operate in bypass mode as long as the input supply voltage is sufficient to drive the LEDs. Dropout voltage of all three channels is monitored and charge pump gain is set to 1.5x if any one driver does not have enough headroom to drive the LED. When the part enters Power Save mode the output capacitor is connected to the input supply through a resistive path. See Power Save mode description for details.

The mode selection logic utilizes digital filtering to prevent glitches of the supply voltage from triggering gain changes. If R-driver current source is connected to battery (CONFIG register, bit R_TO_BATT set to 1) voltage monitoring is disabled in R output, but still functional in G and B output.

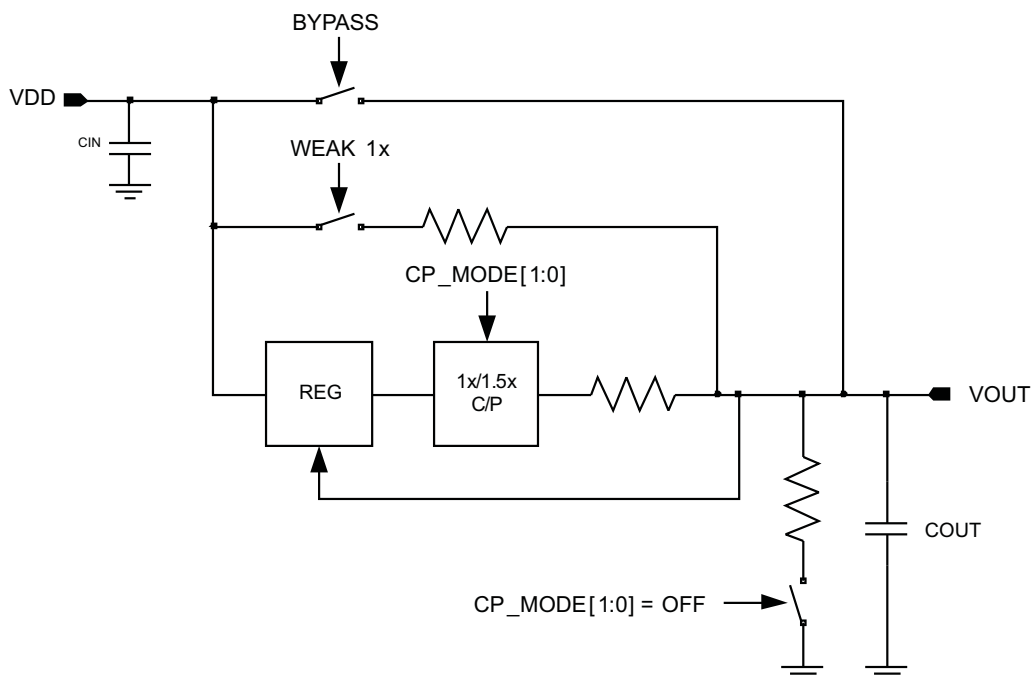

Figure 1. Functional Model of Charge Pump

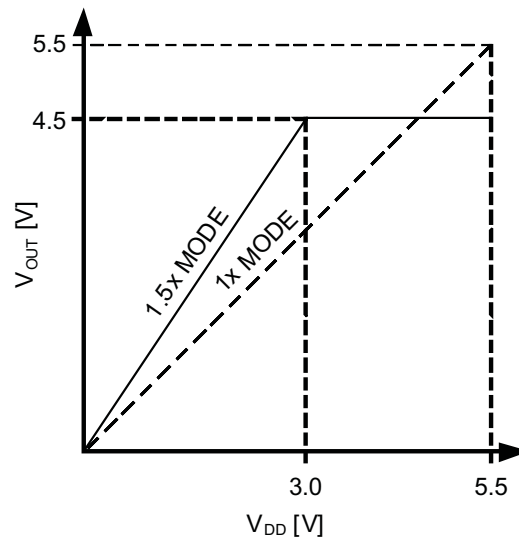

Figure 2. Charge Pump Output Voltage

LED DRIVER OPERATIONAL DESCRIPTION

The TPS68401/TPS68402 has three independent constant current LED drivers with 8-bit PWM control. Output current is programmed through the I²C register and ranges from 0 mA to 25.5 mA with 8-bit resolution. PWM duty cycle is controlled either by program instructions or R/G/B PWM registers. Green and blue channels are always connected to the charge pump output V_{OUT} . The red channel is connected to either V_{OUT} or V_{DD} depending on R_TO_BAT bit setting of the CONFIG register. If red channel is connected to V_{DD} , automatic charge pump gain control is not used for this output. Connecting the red channel to V_{DD} provides better efficiency when driving LEDs with low VF or the supply voltage is high enough to drive a LED with high VF.

PWM frequency is either 256 Hz or 558 Hz and is selected through PWM_HF bit in the CONFIG register. Linear and logarithmic PWM duty-cycle-to-input response is selectable through the LOG_EN bit of the ENABLE register. LOG_EN bit controls PWM response for all three channels. Logarithmic response is approximated by piece-wise-linear function as shown below.

When the external clock source is selected for driving the PWM, PWM frequency scales with the external clock frequency. Nominal 256-Hz PWM frequency requires external clock frequency of 32.768 kHz.

PWM CONTROL

Table 1. PWM Value and Output in LIN and EXP Mode

PWM REGISTER VALUE	PWM OUTPUT		PWM REGISTER VALUE	PWM OUTPUT	
	LIN	EXP		LIN	EXP
0	0	0	128	128	64
1	1	0	129	129	65
2	2	1	130	130	66
3	3	1	131	131	67
4	4	2	132	132	68
5	5	2	133	133	69
...
61	61	30	189	189	125
62	62	31	190	190	126
63	63	31	191	191	127
64	64	32	192	192	129
65	65	32	193	193	131
66	66	33	194	194	133
...
125	125	62	253	253	251
126	126	63	254	254	253
127	127	63	255	255	255

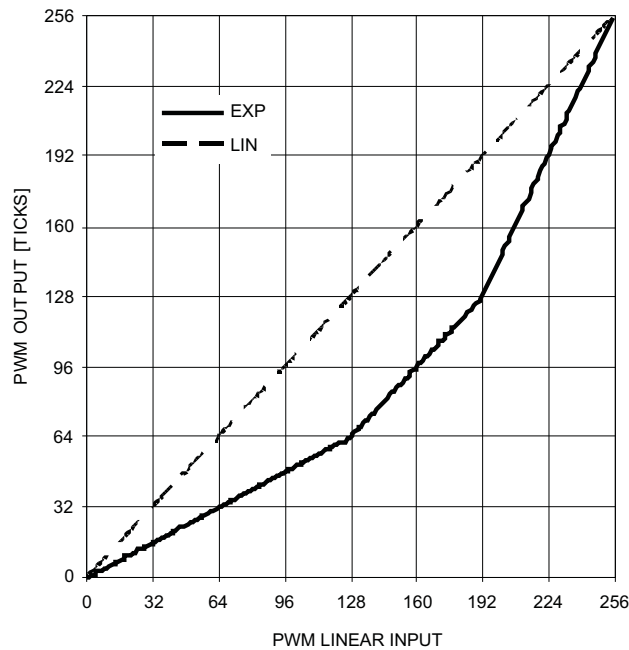

Figure 3. Graph of PWM Output vs. PWM Input

Table 2. LED Channel Output Current Control

REGISTER	BITS	VALUE	CHANNEL CURRENT
R_CURRENT, G_CURRENT, B_CURRENT	7:0	0x00	0.0 mA
		0x01	0.1 mA
		↓	↓
		0xAE	17.4 mA
		0xAF	17.5 mA
		0xB0	17.6 mA
		↓	↓
		0xFE	25.4 mA
		0xFF	25.5 mA

DATA TRANSMISSION

TPS68401/TPS68402 features an I²C slave interface for communication to a controlling microprocessor. SDA, SCL, CLK_32K and TRIG pins input levels are defined by EN pin. EN pin is used as voltage reference for logic inputs and therefore no dedicated VIO pin is required.

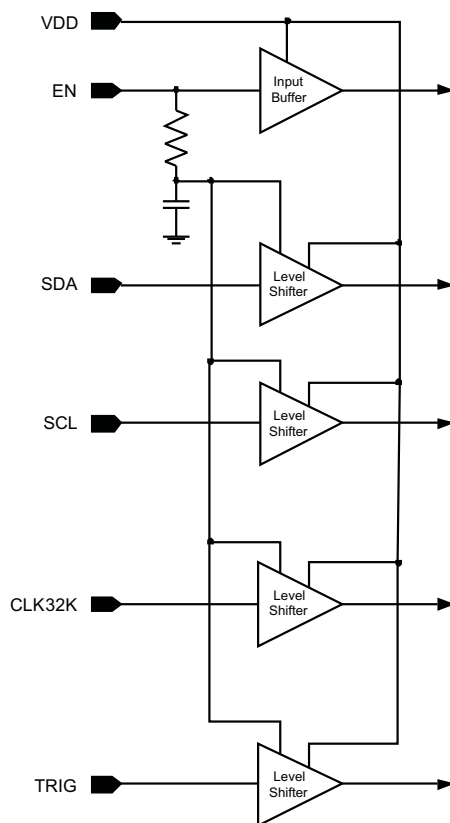

Figure 4. Internal Logic Level Shifters

SUBADDRESS DEFINITION

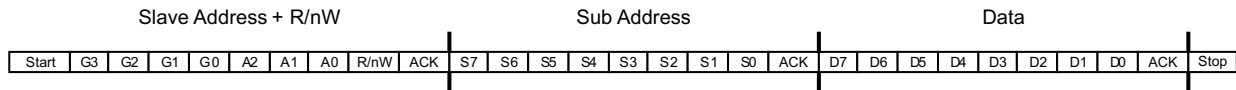

Figure 5. Subaddress in I²C Transmission

- Start – Start Condition
- ACK – Acknowledge
- G(3:0) – Group ID: Address fixed at 0110b
- S(7:0) – Subaddress: defined per register map
- A(2:0) – Device address: Device address is selectable via ADDR_SEL input pin.
- D(7:0) – Data; Data to be loaded into the device
- R/nW – Read / not Write select bit
- Stop – Stop condition

Table 3. Subaddress Bits Defined by ADDR_SEL Inputs

ADDR_SEL [1:0]	A [2:0]
00	010
01	011
10	100
11	101

The address bits used in the slave address portion of the I²C transaction are defined by the device pins ADDR_SEL1 and ADDR_SEL0 (combined as ADDR_SEL [1:0] above). The table above gives the values of the address bits for all combinations of ADDR_SEL1 and ADDR_SEL0.

I²C BUS OPERATION

The I²C bus is a communications link between a controller and a series of slave terminals. The link is established using a two-wired bus consisting of a serial clock signal (SCL) and a serial data signal (SDA). The serial clock is sourced from the controller in all cases where the serial data line is bi-directional for data communication between the controller and the slave terminals. Each device has an open drain output to transmit data on the serial data line. An external pull-up resistor must be placed on the serial data line to pull the drain output high during data transmission.

Data transmission is initiated with a start bit from the controller as shown in Figure 6. The start condition is recognized when the SDA line transitions from high to low during the high portion of the SCL signal. Upon reception of a start bit, the device will receive serial data on the SDA input and check for valid address and control information. If the appropriate group and address bits are set for the device, then the device will issue an acknowledge pulse and prepare the receive subaddress data. Subaddress data is decoded and responded to as per the Register Map section of this document. Data transmission is completed by either the reception of a stop condition or the reception of the data word sent to the device. A stop condition is recognized as a low to high transition of the SDA input during the high portion of the SCL signal. All other transitions of the SDA line must occur during the low portion of the SCL signal. An acknowledge is issued after the reception of valid address, sub-address and data words. The I²C interface will auto-sequence through register addresses, so that multiple data words can be sent for a given I²C transmission.

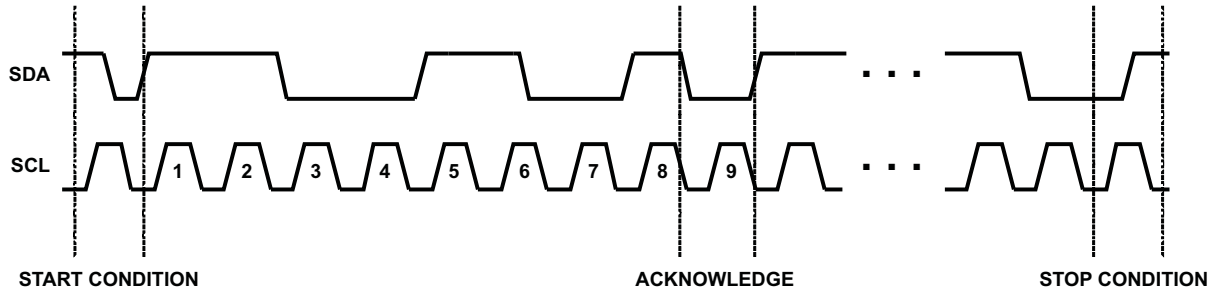

Figure 6. I²C Start / Stop / Acknowledge Protocol

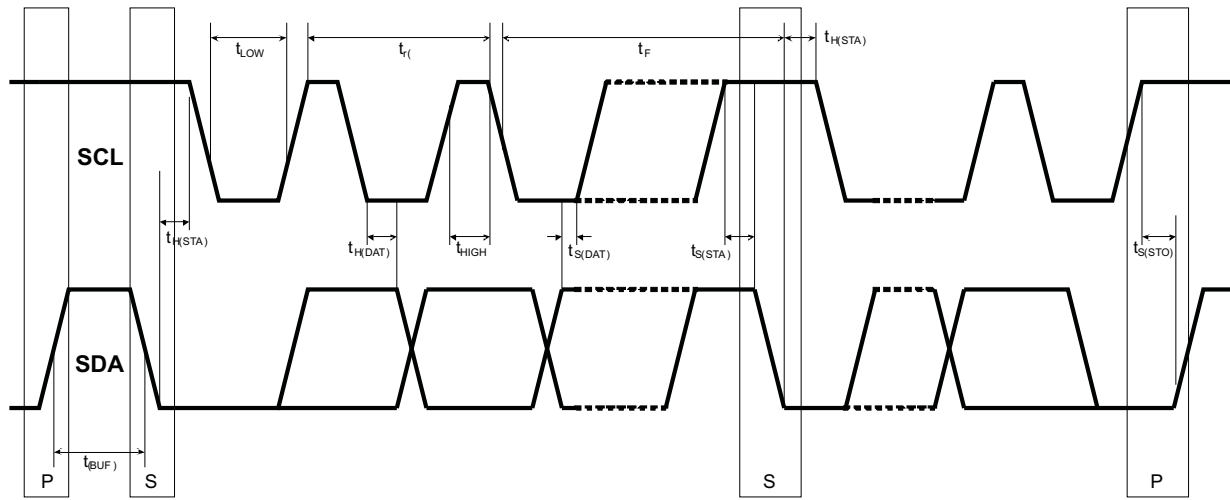

Figure 7. I²C Data Transmission Timing

DATA TRANSMISSION TIMING

 $V_{BAT} = 3.6 \pm 5\%$, $T_A = 25\text{ }^\circ\text{C}$, $C_L = 100\text{ pF}$ (unless otherwise noted)

PARAMETER	TEST CONDITIONS	MIN	TYP	MAX	UNIT
$f_{(SCL)}$ Serial clock frequency				100	KHz
				400	
$t_{(BUF)}$ Bus free time between stop and start condition	SCL = 100 kHz	4.7			μs
	SCL = 400 kHz	1.3			
$t_{(SP)}$ Tolerable spike width on bus	SCL = 100 kHz			50	ns
	SCL = 400 kHz				
t_{LOW} SCL low time	SCL = 100 kHz	4.7			μs
	SCL = 400 kHz	1.3			
t_{HIGH} SCL high time	SCL = 100 kHz	4			μs
	SCL = 400 kHz	0.6			
$t_{S(DAT)}$ SDA → SCL setup time	SCL = 100 kHz	250			ns
	SCL = 400 kHz	100			
$t_{S(STA)}$ Start condition setup time	SCL = 100 kHz	4.7			μs
	SCL = 400 kHz	0.6			
$t_{S(STO)}$ Stop condition setup time	SCL = 100 kHz	4			μs
	SCL = 400 kHz	0.6			
$t_{H(DAT)}$ SDA → SCL hold time	SCL = 100 kHz	0		3.45	μs
	SCL = 400 kHz	0		0.9	
$t_{H(STA)}$ Start condition hold time	SCL = 100 kHz	4			μs
	SCL = 400 kHz	0.6			
$t_{r(SCL)}$ Rise time of SCL Signal	SCL = 100 kHz			1000	ns
	SCL = 400 kHz			300	
$t_{f(SCL)}$ Fall time of SCL Signal	SCL = 100 kHz			300	ns
	SCL = 400 kHz			300	
$t_{r(SDA)}$ Rise time of SDA Signal	SCL = 100 kHz			1000	ns
	SCL = 400 kHz			300	
$t_{f(SDA)}$ Fall time of SDA Signal	SCL = 100 kHz			300	ns
	SCL = 400 kHz			300	

FUNCTIONAL DESCRIPTION OF DEVICE PINS

ADDR_SEL0 AND ADDR_SEL1 PINS

ADDR_SEL0 and ADDR_SEL1 pins define the chip I²C address. Pins are referenced to V_{DD} signal level. See Data Transmission section for I²C address definitions.

GENERAL PURPOSE OUTPUT PIN

The TPS68401/TPS68402 has one dedicated general purpose output pin (GPO) with digital CMOS output. High-level output voltage is defined by V_{DD} and no pull-up resistor is needed. GPO output is controlled by GPO bit of the GPO register.

INT PIN

The INT pin is used to issue an interrupt to a host processor when END instruction is executed and the INT bit is set (see Instruction Description section for details). The INT pin can also be configured as a GPO pin by setting the INT_AS_GPO bit of the GPO register. When configured as INT pin it has an open drain output and requires an external pull-up resistor. As GPO pin it has a digital CMOS output, high-level output voltage is defined by V_{DD}, and no pull-up resistor is needed. In GPO mode the output is controlled by the INT bit of the GPO register.

TRIG PIN

TRIG pin is used to send and receive trigger pulses between multiple TPS68401/TPS68402 devices for pattern synchronization. TRIG is an open drain output and requires an external pull-up resistor. External trigger input signal must be at least two 32-kHz clock cycles long to be recognized. Trigger output signal is three 32-kHz clock cycles long. If TRIG pin is not used on application, it should be connected to GND.

CLK_32K PIN

CLK_32K pin is used for connecting external 32.768-kHz clock to TPS68401/TPS68402. Connecting several devices to the same clock source ensures synchronous instruction execution. When external clock source is used the internal oscillator is shut down during automatic power save mode to achieve lowest possible current consumption. An external clock source is not required for device operation. If external clock is not used, CLK_32K pin should be connected to GND.

CLK_32K EXTERNAL CLOCK DETECTION

The instruction execution engine and PWM are clocked either by an internal 32.768-kHz or an external clock. The user can manually select internal or external clock or enable automatic clock source selection. In automatic mode the TPS68401/TPS68402 monitors the CLK32K pin; If external clock frequency is < 15 kHz, stuck-at-zero, or stuck-at-one, the clock detector indicates that no external clock is present and switches to internal clock source. It switches back to external clock source once the external clock is detected again. In any mode (manual or automatic selection) the clock source can be checked by reading the EXT_CLK_USED bit of the STATUS register. Clock source selection is controlled by CONFIG register bits INT_CLK_EN and CLK_DET_EN. External clock detection is disabled in POWER SAVE mode.

When external clock source is selected, instruction timing and PWM frequency scale with the external clock frequency. Nominal external clock frequency is 32.768 kHz.

MODES OF OPERATION

RESET

In the RESET mode all the internal registers are reset to the default values. Reset is initiated if 0xFFh is written into the RESET register or internal power-up clear (PUC) is activated. PUC will activate when supply voltage is connected to V_{DD} pin or when the supply voltage drops below the nPUC_VIL level. Once V_{DD} rises above nPUC_VIH, PUC is released and the chip will continue to the STANDBY mode. CHIP_EN control bit is low after PUC by default.

SHUTDOWN

Whenever the EN pin is pulled low the device enters SHUTDOWN mode. All functions are disabled, including the serial interface. This is the lowest power mode.

STANDBY

STANDBY mode is entered if the CHIP_EN bit of the ENABLE register is set to 0 and reset is not active. Registers can be written to in this mode with the exception of the EXEC bits of the ENABLE register (R_EXEC[1:0], G_EXEC[1:0], B_EXEC[1:0]). Control bits are effective after start up.

STARTUP

When CHIP_EN bit of the ENABLE register is written 1 and EN pin is high, the chip executes the internal startup sequence to power up analog blocks (V_{REF} , bias, oscillator etc.). If the chip temperature rises too high, the over temperature shutdown (OTS) disables the chip and automatically re-enters STARTUP mode, until no thermal shutdown event is present.

NORMAL

During NORMAL mode the user controls the chip using the control registers. If EN pin is set low, the CHIP_EN bit is reset to 0.

POWER SAVE

In POWER SAVE mode analog blocks are disabled to minimize power consumption. See the Power Save Mode section for further information.

MODE TRANSITIONS

Setting the CHIP_EN bit of the ENABLE register to 0 resets the program counters (PC) but does not change the LED controller operational mode (see NORMAL MODE settings). Pulling the EN pin low resets the CHIP_EN bit and PC but does not affect operational mode (see NORMAL MODE settings).

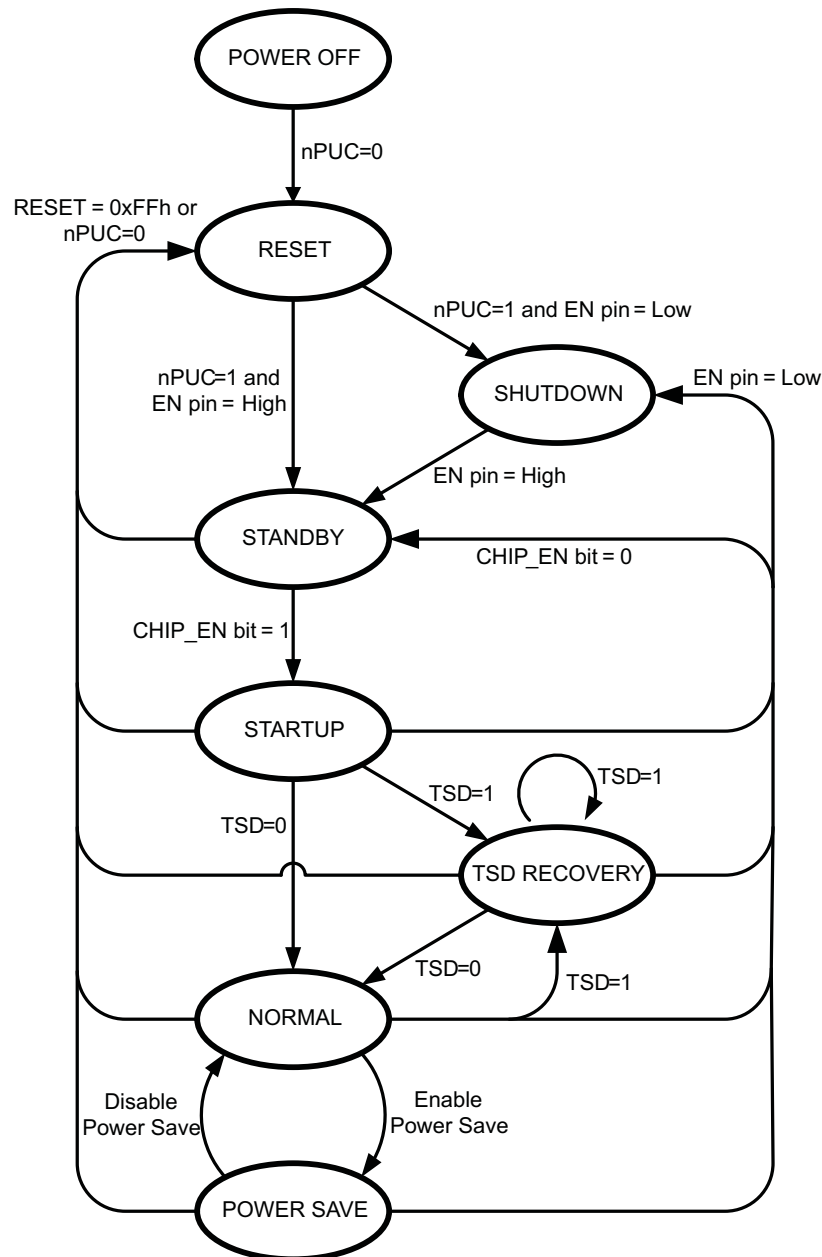

Figure 8. Device Startup Flow and Modes of Operation

POWER SAVE MODE

Automatic power save mode is enabled when PWRSAVE_EN bit in the CONFIG register is set to 1. In power save mode all analog blocks are powered down with exception of charge pump protection circuits, provided external clock source is used to run the PWM. If internal clock source has been selected, only charge pump and LED drivers are disabled and the digital part of the LED controller remains active. In both cases charge pump enters a special 1x mode to keep the output at battery level. During program execution the device can enter power save if there is no PWM activity in R, G and B outputs for > 50ms. To prevent the device from entering power-save mode for short periods of time the device does a command look-ahead. In every instruction cycle R, G, B commands are analyzed, and if there is sufficient time left with no PWM activity, device will enter power save mode. In power save mode program execution continues uninterrupted. When a command that requires PWM activity is executed, the device starts up automatically. The following table describes commands and conditions that can activate power save mode. All channels (R, G, and B) need to meet power save condition in order to enable power save.

POWER SAVE MODE can only be entered when no channel is in the LOAD MODE, all PWM values are zero or channel is disabled, and C/P mode is either OFF or Automatic.

Table 4. Requirements for Power Save By Command

COMMAND	POWER SAVE REQUIREMENT
WAIT	Enter power save only if PWM is zero and wait is greater than 50 ms.
RAMP	Enter power save only if ramp ends with PWM set to zero and there is 50 ms before the next command.
TRIGGER	Enter power save only if PWM is zero while waiting for trigger.
END	Enter power save only if PWM is zero or reset bit of command is set to 1.
SET	Enter power save only if PWM is set to zero and the next command generates at least a 50-ms wait.
Other	Cannot enter power save mode

LED CONTROLLER OPERATIONAL MODES (NORMAL MODE)

In NORMAL MODE, operation of the red, green, and blue LED controller is defined independently by the OP_MODE, and respective R/G/B_PC, R/G/B_PWM, and R/G/B_CURRENT registers. The R/G/B CURRENT registers define the maximum output current for the respective channel. MODE control bits are synchronized to a 32-kHz clock.

In the following, PC denotes either R_PC, G_PC, or B_PC program counter. MODE denotes either R_MODE, G_MODE, or B_MODE bits of the OP_MODE register.

DISABLED MODE

LED output current is set to 0 and PC counter is reset.

LOAD MODE

The device can store 16 16-bit commands for each channel (R, G, B). Due to the 8-bit format of the I²C protocol two writes are required to load a single instruction. The device supports auto-increment addressing to reduce program load time. Register address is incremented after each 8 data bits which allows the whole program memory to be written in a single I²C write sequence. Program memory is defined in the register table. Read / write access to program memory is allowed only in LOAD mode and only to the channel in LOAD mode. LOAD mode resets respective channel's PC. Program execution on all other channels is halted and PWM value remains static while at least one channel is in LOAD mode. Program execution continues when all channels are out of LOAD program mode.

RUN MODE

In RUN mode the LED controller executes instructions stored in program memory. Execution is controlled by the R, G, and B program counters (R_PC, G_PC, B_PC) and the ENABLE register. For details refer to RUN MODE OPTIONS section. Program start position can be determined by writing to the PC registers. If program counter runs to end (15) the next command will be executed from program location 0. If internal PWM clock source is selected in RUN mode, the LED controller must be disabled (MODE = 00b) before disabling the chip (with CHIP_EN bit or EN pin) to ensure that the sequence starts from the correct program counter (PC) value when restarting the sequence. PC registers are synchronized to a 32-kHz clock.

DIRECT MODE

In DIRECT mode the LED channels can be controlled independently through the I²C interface. For each channel there is a PWM control register (R_PWM, G_PWM, B_PWM) which contains the PWM duty cycle. If the charge pump is set to automatic 1x / 1.5x mode selection, PWM values need to be written 0 before disabling the drivers (MODE = 00b) to ensure proper automatic gain change operation.

MODE TRANSITIONS

A transition between operational modes aborts the instruction being executed (if any), resets the PC and sets the PWM duty cycle to 0. The channel current setting is not affected.

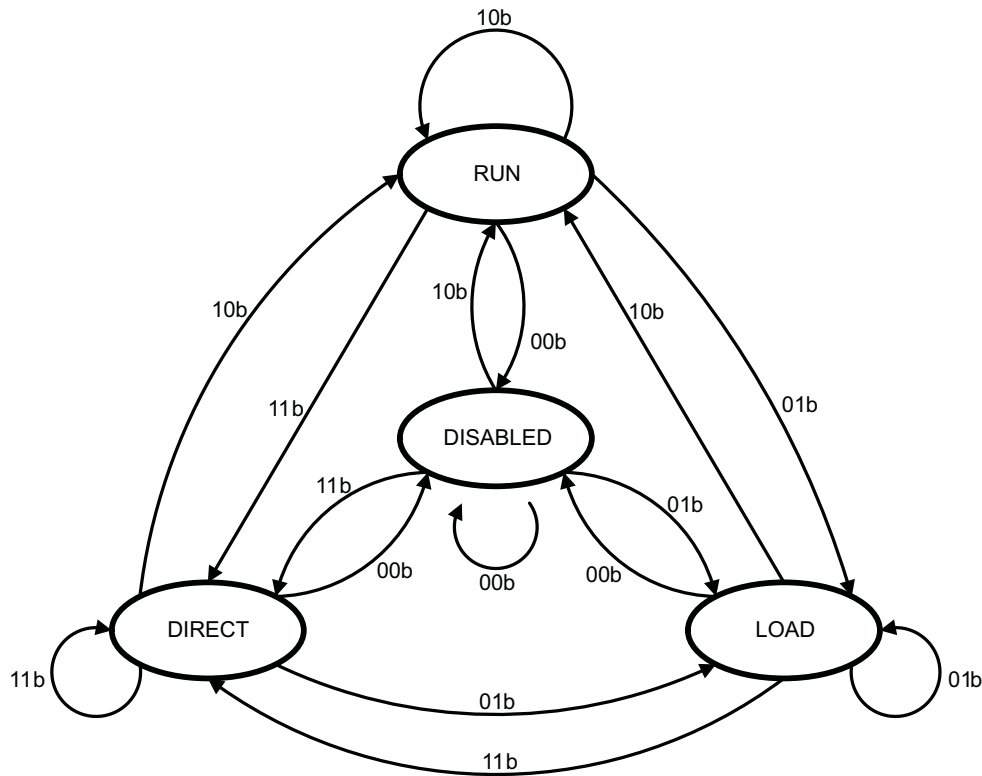

NORMAL MODE

Bit settings refer to the R/G/B_MODE[1:0] bits of the OP_MODE register.

Figure 9. Operational Modes of LED Controller in NORMAL Mode of Operation

RUN MODE SETTINGS

Run mode is set independently for each channel in the ENABLE register. In the following PC denotes either R_PC, G_PC, or B_PC program counter. EXEC denotes either R_EXEC, G_EXEC, or B_EXEC bits of the ENABLE register.

HOLD

Wait until current command is finished then stop while EXEC[1:0] = 00b (Hold). PC can be read or written only in this mode.

STEP

Execute instruction defined by PC, increment PC and change EXEC[1:0] to 00b (Hold).

CONTINUE

Start program execution at PC value, increment PC and continue.

EXECUTE

Execute instruction defined by PC, do not update PC, change EXEC[1:0] to 00b (Hold).

MODE TRANSITIONS

A transition between run modes does not abort the instruction being executed. PC is updated before mode transition. Note that PC is also incremented when transitioning out of EXECUTE mode.

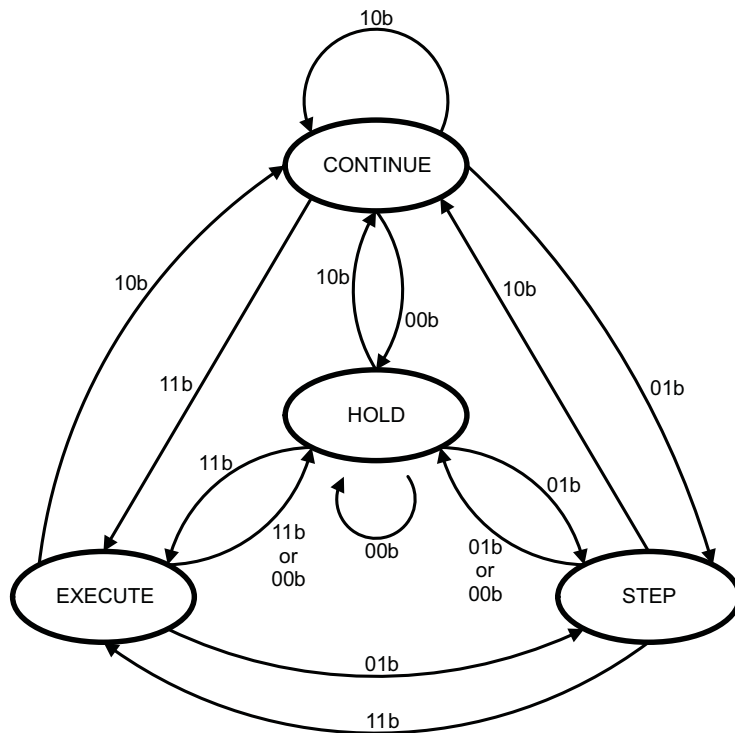

RUN MODE

Bit settings refer to the R/G/B_EXEC[1:0] bits of the ENABLE register.

Figure 10. Run Mode State Diagram

INSTRUCTION DESCRIPTION

The three channels are independent, except for the trigger connections between the channels. The following table describes the binary format used. In this implementation, there are 16 program steps available per channel.

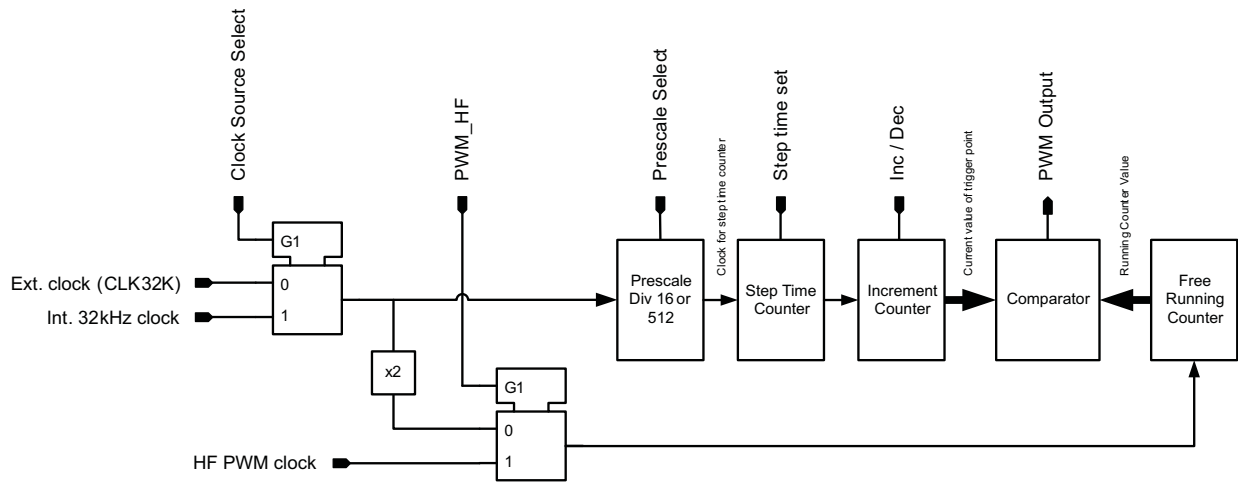

Figure 11. Simplified Block Diagram of PWM

RAMP / WAIT

B15	B14	B13	B12	B11	B10	B9	B8	B7	B6	B5	B4	B3	B2	B1	B0
0	x	x	x	x	x	x	x	x	x	x	x	x	x	x	x
	prescale 0 = 16 1 = 512	step time 1 to 63					sign 0= INC 1= DEC	number of steps 0 to 127							

The ramp command generates a PWM ramp starting from the current value. At each ramp step the PWM value is incremented or decremented by one. Time for one step is defined by prescale and step time bits. The number of increments executed by the instruction is defined by number of steps which has a maximum value of 127 or half of full scale. If, during a ramp command, PWM reaches minimum / maximum (0 / 255), the ramp command will continue for the remaining number of steps without changing the PWM value (PWM value saturates). This enables the ramp command to be used as combined ramp and wait command in single instruction.

Ramp command can be used as a single step time wait instruction when increment is zero.

SET PWM

B15	B14	B13	B12	B11	B10	B9	B8	B7	B6	B5	B4	B3	B2	B1	B0
0	1	0	0	0	0	0	0	x	x	x	x	x	x	x	x
PWM value															

Set PWM output value from 0 to 255 in a single instruction.

BRANCH

B15	B14	B13	B12	B11	B10	B9	B8	B7	B6	B5	B4	B3	B2	B1	B0
1	0	1	x	x	x	x	x	x	x	x	x	x	x	x	x
			loop count 0 to 63 (0 = loop forever)						not used			step number			

Loop instruction. Code between (step number) and BRANCH command will be executed (loop count + 1) times. Set (loop count) = 0 for infinite looping. Nested looping is supported. The number of nested loops is not limited.

GO TO START

B15	B14	B13	B12	B11	B10	B9	B8	B7	B6	B5	B4	B3	B2	B1	B0
0	0	0	0	0	0	0	0	0	0	0	0	0	0	0	0

Command resets program counter register and continues executing program from the 00H location.

END

B15	B14	B13	B12	B11	B10	B9	B8	B7	B6	B5	B4	B3	B2	B1	B0
1	1	0	INT	RST	x	x	x	x	x	x	x	x	x	x	x
			interrupt	reset											
					0 = Keep the current PWM value 1 = Set PWM value to 0										
					0 = Do not issue interrupt 1 = Issue interrupt and set corresponding status bit high. Interrupt is cleared by reading interrupt status register.										

Stops program execution. Set (interrupt) = 1 to issue an interrupt on the INT pin. If INT is used it must be cleared before pulling the EN pin low or writing CHIP_EN low.

TRIGGER

B15	B14	B13	B12	B11	B10	B9	B8	B7	B6	B5	B4	B3	B2	B1	B0
1	1	1	EXT	x	x	B	G	R	EXT	x	x	B	G	R	x
			Wait for trigger R=RED; G=GREEN; B=BLUE; EXT=EXTERNAL 1 = Wait for trigger from specified channel. Own channel position is ignored. 0 = Continue without wait						Issue trigger R=RED; G=GREEN; B=BLUE; EXT=EXTERNAL 1 = Issue trigger for specified channel. Own channel position is ignored. 0 = Continue without issuing trigger						

Used to synchronize channels and / or multiple units. The wait for trigger command is executed until all defined trigger have been received. An external trigger is ignored by the issuing channel / device. External trigger input signal must be at least two 32-kHz clock cycles long to be recognized. Trigger output signal is three 32-kHz clock cycles long. External trigger signal is active low, i.e. when trigger is send / received the pin is pulled to GND. Sent external trigger is masked, i.e. the device which has sent the trigger will not recognize it. If send and wait external trigger are used on the same command, the send external trigger is executed first, then the wait external trigger. Channel (R, G, or B) waiting for its own trigger is not allowed.

Table 5. ADDRESS REGISTER MAP

REGISTER	ADDRESS (HEX)	NAME	DEFAULT VALUE	DESCRIPTION
0	0	ENABLE	0000 0000	Chip enable and execution control
1	1	OP_MODE	0000 0000	RGB operating mode control
2	2	R_PWM	0000 0000	Red channel PWM value
3	3	G_PWM	0000 0000	Green channel PWM value
4	4	B_PWM	0000 0000	Blue channel PWM value
5	5	R_CURRENT	1010 1111	Red channel current limit value
6	6	G_CURRENT	1010 1111	Green channel current limit value
7	7	B_CURRENT	1010 1111	Blue channel current limit value
8	8	CONFIG	0000 0000	Charge pump configuration
9	9	R_PC	0000 0000	Red channel program counter value
10	0A	G_PC	0000 0000	Green channel program counter value
11	0B	B_PC	0000 0000	Blue channel program counter value
12	0C	STATUS	0000 0000	Clock and interrupt status
13	0D	RESET	0000 0000	Device reset
14	0E	GPO	1000 0000	GPO configuration and value
15	N/A	N/A	N/A	Register not implemented
16	10	PROG_MEM_R1_H	0000 0000	Red channel instruction 1 MSB
17	11	PROG_MEM_R1_L	0000 0000	Red channel instruction 1 LSB
...
46	2E	PROG_MEM_R16_H	0000 0000	Red channel instruction 16 MSB
47	2F	PROG_MEM_R16_L	0000 0000	Red channel instruction 16 LSB
48	30	PROG_MEM_G1_H	0000 0000	Green channel instruction 1 MSB
49	31	PROG_MEM_G1_L	0000 0000	Green channel instruction 1 LSB
...
78	4E	PROG_MEM_G16_H	0000 0000	Green channel instruction 16 MSB
79	4F	PROG_MEM_G16_L	0000 0000	Green channel instruction 16 LSB
80	50	PROG_MEM_B1_H	0000 0000	Blue channel instruction 1 MSB
81	51	PROG_MEM_B1_L	0000 0000	Blue channel instruction 1 LSB
...
110	6E	PROG_MEM_B16_H	0000 0000	Blue channel instruction 16 MSB
111	6F	PROG_MEM_B16_L	0000 0000	Blue channel instruction 16 LSB

ENABLE REGISTER (ENABLE)

Address – 0x00h

DATA BIT	D7	D6	D5	D4	D3	D2	D1	D0
FIELD NAME	LOG_EN	CHIP_EN	R_EXEC[1:0]		G_EXEC[1:0]		B_EXEC[1:0]	
READ/WRITE	R/W	R/W	R/W	R/W	R/W	R/W	R/W	R/W
RESET VALUE	0	0	0	0	0	0	0	0

FIELD NAME	BIT DEFINITION
LOG_EN	Enable logarithmic current adjustment mode
CHIP_EN	Chip enable: Forcing EN pin low resets CHIP_EN to zero. See state diagram for details.
R_EXEC[1:0]	Program execution control for red channel 00b – Hold: Finish current instruction, then stop until R_EXEC[1:0] changes. 01b – Step: Finish current instruction, increment R_PC and set EXEC to hold 10b – Continue: Execute command indicated by PC, then increment R_PC 11b – Execute: Execute command indicated by R_PC, then set R_EXEC[1:0] to 00b (Hold)
G_EXEC[1:0]	Program execution control for green channel 00b – Hold: Finish current instruction, then stop until G_EXEC[1:0] changes 01b – Step: Finish current instruction, increment R_PC and set EXEC to hold 10b – Continue: Execute command indicated by PC, then increment G_PC 11b – Execute: Execute command indicated by G_PC, then set G_EXEC[1:0] to 00b (Hold)
B_EXEC[1:0]	Program execution control for blue channel 00b – Hold: Finish current instruction, then stop until B_EXEC[1:0] changes 01b – Step: Finish current instruction, increment R_PC and set EXEC to hold 10b – Continue: Execute command indicated by PC, then increment B_PC 11b – Execute: Execute command indicated by B_PC, then set B_EXEC[1:0] to 00b (Hold)

OPERATION MODE REGISTER (OP_MODE)

Address – 0x01h

DATA BIT	D7	D6	D5	D4	D3	D2	D1	D0
FIELD NAME	N/A	N/A	R_MODE[1:0]		G_MODE[1:0]		B_MODE[1:0]	
READ/WRITE	R/W	R/W	R/W	R/W	R/W	R/W	R/W	R/W
RESET VALUE	0	0	0	0	0	0	0	0

FIELD NAME	BIT DEFINITION
R_MODE[1:0]	Red channel operating mode 00b – Disable 01b – Load: Load program to instruction registers and reset R_PC 10b – Run: Execute commands according to R_EXEC[1:0] setting in ENABLE register 11b – Direct: Direct control (through R_PWM register)
G_MODE[1:0]	Green channel operating mode 00b – Disable 01b – Load: Load program to instruction registers and reset G_PC 10b – Run: Execute commands according to G_EXEC[1:0] setting in ENABLE register 11b – Direct: Direct control (through G_PWM register)
B_MODE[1:0]	Blue channel operating mode 00b – Disable 01b – Load: Load program to instruction registers and reset B_PC 10b – Run: Execute commands according to B_EXEC[1:0] setting in ENABLE register 11b – Direct: Direct control (through B_PWM register)

RED CHANNEL PWM CONTROL REGISTER (R_PWM)

Address – 0x02h

DATA BIT	D7	D6	D5	D4	D3	D2	D1	D0
FIELD NAME	R_PWM[7:0]							
READ/WRITE	R/W	R/W	R/W	R/W	R/W	R/W	R/W	R/W
RESET VALUE	0	0	0	0	0	0	0	0

FIELD NAME	BIT DEFINITION
R_PWM[7:0]	Red channel PWM value used when R_MODE is Direct

GREEN CHANNEL PWM CONTROL REGISTER (G_PWM)

Address – 0x03h

DATA BIT	D7	D6	D5	D4	D3	D2	D1	D0
FIELD NAME	G_PWM[7:0]							
READ/WRITE	R/W	R/W	R/W	R/W	R/W	R/W	R/W	R/W
RESET VALUE	0	0	0	0	0	0	0	0

FIELD NAME	BIT DEFINITION
G_PWM[7:0]	Green channel PWM value used when G_MODE is Direct

BLUE CHANNEL PWM CONTROL REGISTER (B_PWM)

Address – 0x04h

DATA BIT	D7	D6	D5	D4	D3	D2	D1	D0
FIELD NAME	B_PWM[7:0]							
READ/WRITE	R/W	R/W	R/W	R/W	R/W	R/W	R/W	R/W
RESET VALUE	0	0	0	0	0	0	0	0

FIELD NAME	BIT DEFINITION
B_PWM[7:0]	Blue channel PWM value used when B_MODE is Direct

RED CHANNEL CURRENT CONTROL REGISTER (R_CURRENT)

Address – 0x05h

DATA BIT	D7	D6	D5	D4	D3	D2	D1	D0
FIELD NAME	R_CURRENT[7:0]							
READ/WRITE	R/W	R/W	R/W	R/W	R/W	R/W	R/W	R/W
RESET VALUE	1	0	1	0	1	1	1	1

FIELD NAME	BIT DEFINITION
R_CURRENT[7:0]	Red channel current setting
	0000 0000b - 0.0 mA
	0000 0001b - 0.1 mA
	0000 0002b - 0.2 mA
	...
	1010 1111b - 17.5 mA (default)
	...
	1111 1101b - 25.3 mA
	1111 1110b - 25.4 mA
	1111 1111b - 25.5 mA

GREEN CHANNEL CURRENT CONTROL REGISTER (G_CURRENT)

Address – 0x06h

DATA BIT	D7	D6	D5	D4	D3	D2	D1	D0
FIELD NAME	G_CURRENT[7:0]							
READ/WRITE	R/W	R/W	R/W	R/W	R/W	R/W	R/W	R/W
RESET VALUE	1	0	1	0	1	1	1	1

FIELD NAME	BIT DEFINITION
G_CURRENT[7:0]	Green channel current setting
	0000 0000b - 0.0 mA
	0000 0001b - 0.1 mA
	0000 0002b - 0.2 mA
	...
	1010 1111b - 17.5 mA (default)
	...
	1111 1101b - 25.3 mA
	1111 1110b - 25.4 mA
	1111 1111b - 25.5 mA

BLUE CHANNEL CURRENT CONTROL REGISTER (B_CURRENT)

Address – 0x07h

DATA BIT	D7	D6	D5	D4	D3	D2	D1	D0
FIELD NAME	B_CURRENT[7:0]							
READ/WRITE	R/W	R/W	R/W	R/W	R/W	R/W	R/W	R/W
RESET VALUE	1	0	1	0	1	1	1	1

FIELD NAME	BIT DEFINITION
B_CURRENT[7:0]	Blue channel current setting
	0000 0000b - 0.0 mA
	0000 0001b - 0.1 mA
	0000 0002b - 0.2 mA
	...
	1010 1111b - 17.5 mA (default)
	...
	1111 1101b - 25.3 mA
	1111 1110b - 25.4 mA
	1111 1111b - 25.5 mA

CONFIGURATION CONTROL REGISTER (CONFIG)

Address – 0x08h

DATA BIT	D7 ⁽¹⁾	D6	D5	D4	D3	D2	D1	D0
FIELD NAME	N/A	PWM_HF	PWRSAVE_EN	CP_MODE[1:0]		R_TO_BATT	CLK_DET_EN	INT_CLK_EN
READ/WRITE	N/A	R/W	R/W	R/W	R/W	R/W	R/W	R/W
RESET VALUE	0	0	0	0	0	0	0	0

(1) Bit D7 must be set to 0 at all times. Writing 1 may result in unexpected behavior.

FIELD NAME	BIT DEFINITION
PWM_HF	Source clock for PWM blocks 0b - 256-Hz PWM frequency 1b - 558-Hz PWM frequency
PWRSAVE_EN	0b - Power save mode disabled 1b - Power save mode enabled
CP_MODE[1:0]	Charge pump operating mode 00b – OFF 01b – Forced 1x mode 10b – Forced 1.5x mode 11b – Automatic mode selection
R_TO_BAT	Red channel source supply 0b – Red channel connected to charge pump output (V_{OUT}) 1b – Red channel connected to battery supply (V_{DD})
[CLK_DET_EN INT_CLK_EN]	PWM clock source 00b - Use external clock source (CLK_32) 01b - Use internal clock source, clock detection disabled 10b - Automatically select clock source, clock detection enabled 11b - Use internal clock source, clock detection disabled

RED CHANNEL PROGRAM COUNTER REGISTER (R_PC)

Address – 0x09h

DATA BIT	D7	D6	D5	D4	D3	D2	D1	D0
FIELD NAME	N/A	N/A	N/A	N/A	R_PC[3:0] ⁽¹⁾			
READ/WRITE	N/A	N/A	N/A	N/A	R/W	R/W	R/W	R/W
RESET VALUE	0	0	0	0	0	0	0	0

- (1) R_PC register can only be read or written to when R channel is in HOLD mode (R_EXEC[1:0] = 11b). In STANDBY mode R_PC can be written to but not read. Value is effective after startup. Any change of the R_MODE[1:0] bits reset the R_PC value. For read access device must be in NORMAL mode.

FIELD NAME	BIT DEFINITION
R_PC[3:0]	Red channel program counter

GREEN CHANNEL PROGRAM COUNTER REGISTER (G_PC)

Address – 0x0Ah

DATA BIT	D7	D6	D5	D4	D3	D2	D1	D0
FIELD NAME	N/A	N/A	N/A	N/A	G_PC[3:0] ⁽¹⁾			
READ/WRITE	N/A	N/A	N/A	N/A	R/W	R/W	R/W	R/W
RESET VALUE	0	0	0	0	0	0	0	0

- (1) G_PC register can only be read or written to when G channel is in HOLD mode (G_EXEC[1:0] = 11b). In STANDBY mode G_PC can be written to but not read. Value is effective after startup. Any change of the G_MODE[1:0] bits reset the G_PC value. For read access device must be in NORMAL mode.

FIELD NAME	BIT DEFINITION
G_PC[3:0]	Green channel program counter

BLUE CHANNEL PROGRAM COUNTER REGISTER (B_PC)

Address – 0x0Bh

DATA BIT	D7	D6	D5	D4	D3	D2	D1	D0
FIELD NAME	N/A	N/A	N/A	N/A	B_PC[3:0] ⁽¹⁾			
READ/WRITE	N/A	N/A	N/A	N/A	R/W	R/W	R/W	R/W
RESET VALUE	0	0	0	0	0	0	0	0

- (1) B_PC register can only be read or written to when B channel is in HOLD mode (B_EXEC[1:0] = 11b). In STANDBY mode B_PC can be written to but not read. Value is effective after startup. Any change of the B_MODE[1:0] bits reset the B_PC value. For read access device must be in NORMAL mode.

FIELD NAME	BIT DEFINITION
B_PC[3:0]	Blue channel program counter

STATUS AND INTERRUPT REGISTER (STATUS)

Address – 0x0Ch

DATA BIT	D7	D6	D5	D4	D3	D2	D1	D0
FIELD NAME	N/A	N/A	CP_STATUS[1:0]		EXT_CLK_USED	R_INT	G_INT	B_INT
READ/WRITE	N/A	N/A	R	R	R	R	R	R
RESET VALUE	0	0	0	0	0	0	0	0

FIELD NAME	BIT DEFINITION
CP_STATUS[1:0]	Charge pump operating mode 00b – OFF 01b – Forced 1x mode 10b – Forced 1.5x mode 11b – Power save
EXT_CLK_USED	External clock selected 0b - Internal 32-Hz clock selected 1b - External 32-kHz clock selected
R_INT ⁽¹⁾	Red channel interrupt, set upon channel interrupt generation (END instruction), cleared on read
G_INT ⁽¹⁾	Green channel interrupt, set upon channel interrupt generation (END instruction), cleared on read
B_INT ⁽¹⁾	Blue channel interrupt, set upon channel interrupt generation (END instruction), cleared on read

- (1) Interrupt bits are cleared and INT output pin will go high-impedance (open drain output) after register read access.

RESET CONTROL REGISTER (RESET)

Address – 0x0Dh

DATA BIT	D7	D6	D5	D4	D3	D2	D1	D0
FIELD NAME	RESET[7:0]							
READ/WRITE	W	W	W	W	W	W	W	W
RESET VALUE	0	0	0	0	0	0	0	0

FIELD NAME	BIT DEFINITION
RESET[7:0]	Forced reset state (reset all registers to default values). No I ² C acknowledge will be generated when 0xFFh is written to the RESET register. I ² C acknowledge will be generated for any other pattern written to the register.

GPO CONTROL REGISTER (GPO)

Address – 0x0Eh

DATA BIT	D7	D6	D5	D4	D3	D2	D1	D0
FIELD NAME	ID	N/A	N/A	N/A	N/A	INT_AS_GPO	GPO	INT
READ/WRITE	R	R/W	R/W	R/W	R/W	R/W	R/W	R/W
RESET VALUE	1	0	0	0	0	0	0	0

FIELD NAME	BIT DEFINITION
INT_AS_GPO	INT pin GPO function enable 0b – INT pin functions as interrupt pin 1b – INT pin functions as GPO
GPO	GPO value 0b – Output low 1b – Output high
INT	INT value (when INT_AS_GPO is set to 1) 0b – Output low 1b – Output high
ID	ID bit

PROGRAM MEMORY REGISTERS (PROGRAM MEMORY R, G, B)

Address – 0x10h to 0x2F in pairs (Red)
 – 0x30h to 0x4F in pairs (Green)
 – 0x50h to 0x6F in pairs (Blue)

NOTE

Each program command is composed of two consecutive bytes in the register space. The most significant byte of the command is stored in the lower order address followed by the least significant byte.

DATA BIT	D7	D6	D5	D4	D3	D2	D1	D0
FIELD NAME	CMD_Rn_H[7:0], CMD_Rn_L[7:0]							
READ/WRITE	R/W	R/W	R/W	R/W	R/W	R/W	R/W	R/W
RESET VALUE	0	0	0	0	0	0	0	0

FIELD NAME	BIT DEFINITION
CMD_Rn_H[7:0]	Red channel program command n, most significant byte; Address is 0x10h + 2n and 0 ≤ n ≤ 15. See program commands section for details.
CMD_Rn_L[7:0]	Red channel program command n, least significant byte; Address is 0x11h + 2n and 0 ≤ n ≤ 15. See program commands section for details.

DATA BIT	D7	D6	D5	D4	D3	D2	D1	D0
FIELD NAME	CMD_Gn_H[7:0], CMD_Gn_L[7:0]							
READ/WRITE	R/W	R/W	R/W	R/W	R/W	R/W	R/W	R/W
RESET VALUE	0	0	0	0	0	0	0	0

FIELD NAME	BIT DEFINITION
CMD_Gn_H[7:0]	Green channel program command n, most significant byte; Address is 0x30h + 2n and 0 ≤ n ≤ 15. See program commands section for details.
CMD_Gn_L[7:0]	Green channel program command n, least significant byte; Address is 0x31h + 2n and 0 ≤ n ≤ 15. See program commands section for details.

DATA BIT	D7	D6	D5	D4	D3	D2	D1	D0
FIELD NAME	CMD_Bn_H[7:0], CMD_Bn_L[7:0]							
READ/WRITE	R/W	R/W	R/W	R/W	R/W	R/W	R/W	R/W
RESET VALUE	0	0	0	0	0	0	0	0

FIELD NAME	BIT DEFINITION
CMD_Bn_H[7:0]	Blue channel program command n, most significant byte; Address is 0x50h + 2n and 0 ≤ n ≤ 15. See program commands section for details.
CMD_Bn_L[7:0]	Blue channel program command n, least significant byte; Address is 0x51h + 2n and 0 ≤ n ≤ 15. See program commands section for details.

PACKAGING INFORMATION

Orderable Device	Status ⁽¹⁾	Package Type	Package Drawing	Pins	Package Qty	Eco Plan ⁽²⁾	Lead/ Ball Finish	MSL Peak Temp ⁽³⁾	Samples (Requires Login)
TPS68401C4YFFR	ACTIVE	DSBGA	YFF	20	3000	Green (RoHS & no Sb/Br)	Call TI	Level-1-260C-UNLIM	
TPS68402A0RHFR	ACTIVE	VQFN	RHF	24	3000	Green (RoHS & no Sb/Br)	CU NIPDAU	Level-2-260C-1 YEAR	

⁽¹⁾ The marketing status values are defined as follows:

ACTIVE: Product device recommended for new designs.

LIFEBUY: TI has announced that the device will be discontinued, and a lifetime-buy period is in effect.

NRND: Not recommended for new designs. Device is in production to support existing customers, but TI does not recommend using this part in a new design.

PREVIEW: Device has been announced but is not in production. Samples may or may not be available.

OBsolete: TI has discontinued the production of the device.

⁽²⁾ Eco Plan - The planned eco-friendly classification: Pb-Free (RoHS), Pb-Free (RoHS Exempt), or Green (RoHS & no Sb/Br) - please check <http://www.ti.com/productcontent> for the latest availability information and additional product content details.

TBD: The Pb-Free/Green conversion plan has not been defined.

Pb-Free (RoHS): TI's terms "Lead-Free" or "Pb-Free" mean semiconductor products that are compatible with the current RoHS requirements for all 6 substances, including the requirement that lead not exceed 0.1% by weight in homogeneous materials. Where designed to be soldered at high temperatures, TI Pb-Free products are suitable for use in specified lead-free processes.

Pb-Free (RoHS Exempt): This component has a RoHS exemption for either 1) lead-based flip-chip solder bumps used between the die and package, or 2) lead-based die adhesive used between the die and leadframe. The component is otherwise considered Pb-Free (RoHS compatible) as defined above.

Green (RoHS & no Sb/Br): TI defines "Green" to mean Pb-Free (RoHS compatible), and free of Bromine (Br) and Antimony (Sb) based flame retardants (Br or Sb do not exceed 0.1% by weight in homogeneous material)

⁽³⁾ MSL, Peak Temp. -- The Moisture Sensitivity Level rating according to the JEDEC industry standard classifications, and peak solder temperature.

Important Information and Disclaimer: The information provided on this page represents TI's knowledge and belief as of the date that it is provided. TI bases its knowledge and belief on information provided by third parties, and makes no representation or warranty as to the accuracy of such information. Efforts are underway to better integrate information from third parties. TI has taken and continues to take reasonable steps to provide representative and accurate information but may not have conducted destructive testing or chemical analysis on incoming materials and chemicals. TI and TI suppliers consider certain information to be proprietary, and thus CAS numbers and other limited information may not be available for release.

In no event shall TI's liability arising out of such information exceed the total purchase price of the TI part(s) at issue in this document sold by TI to Customer on an annual basis.

TAPE AND REEL INFORMATION

QUADRANT ASSIGNMENTS FOR PIN 1 ORIENTATION IN TAPE

*All dimensions are nominal

Device	Package Type	Package Drawing	Pins	SPQ	Reel Diameter (mm)	Reel Width W1 (mm)	A0 (mm)	B0 (mm)	K0 (mm)	P1 (mm)	W (mm)	Pin1 Quadrant
TPS68401C4YFFR	DSBGA	YFF	20	3000	180.0	8.4	1.84	2.44	0.81	4.0	8.0	Q1
TPS68402A0RHFR	VQFN	RHF	24	3000	330.0	12.4	4.3	5.3	1.3	8.0	12.0	Q1

TAPE AND REEL BOX DIMENSIONS



*All dimensions are nominal

Device	Package Type	Package Drawing	Pins	SPQ	Length (mm)	Width (mm)	Height (mm)
TPS68401C4YFFR	DSBGA	YFF	20	3000	190.5	212.7	31.8
TPS68402A0RHFR	VQFN	RHF	24	3000	346.0	346.0	29.0

MECHANICAL DATA

RHF (R-PVQFN-N24)

PLASTIC QUAD FLATPACK NO-LEAD

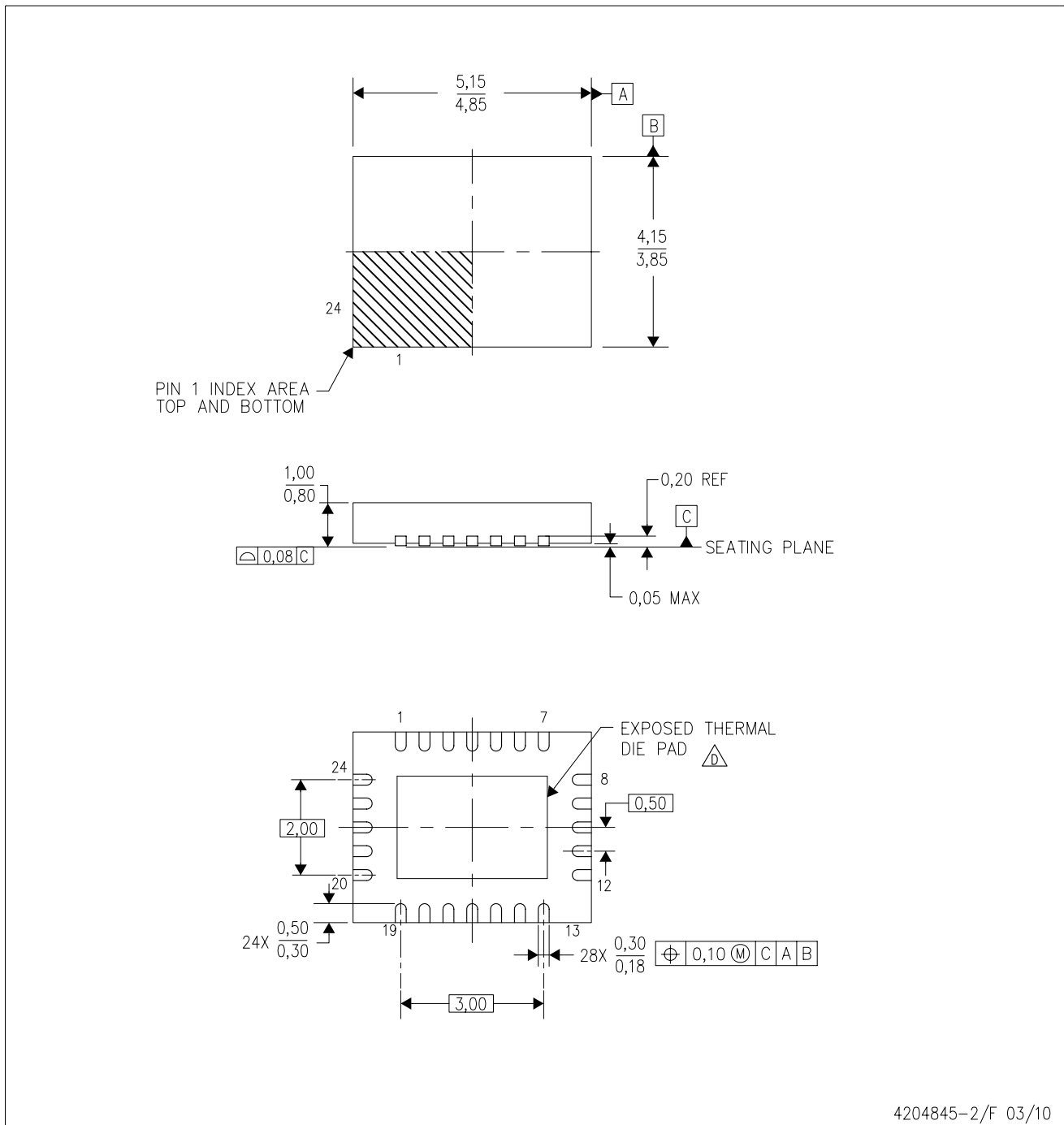

4204845-2/F 03/10

- NOTES:
- A. All linear dimensions are in millimeters. Dimensioning and tolerancing per ASME Y14.5M-1994.
 - B. This drawing is subject to change without notice.
 - C. QFN (Quad Flatpack No-Lead) Package configuration.
 - D. The package thermal pad must be soldered to the board for thermal and mechanical performance. See the Product Data Sheet for details regarding the exposed thermal pad dimensions.
 - E. Falls within JEDEC MO-220.

THERMAL PAD MECHANICAL DATA

RHF (R-PVQFN-N24)

PLASTIC QUAD FLATPACK NO-LEAD

THERMAL INFORMATION

This package incorporates an exposed thermal pad that is designed to be attached directly to an external heatsink. The thermal pad must be soldered directly to the printed circuit board (PCB). After soldering, the PCB can be used as a heatsink. In addition, through the use of thermal vias, the thermal pad can be attached directly to the appropriate copper plane shown in the electrical schematic for the device, or alternatively, can be attached to a special heatsink structure designed into the PCB. This design optimizes the heat transfer from the integrated circuit (IC).

For information on the Quad Flatpack No-Lead (QFN) package and its advantages, refer to Application Report, QFN/SON PCB Attachment, Texas Instruments Literature No. SLUA271. This document is available at www.ti.com.

The exposed thermal pad dimensions for this package are shown in the following illustration.

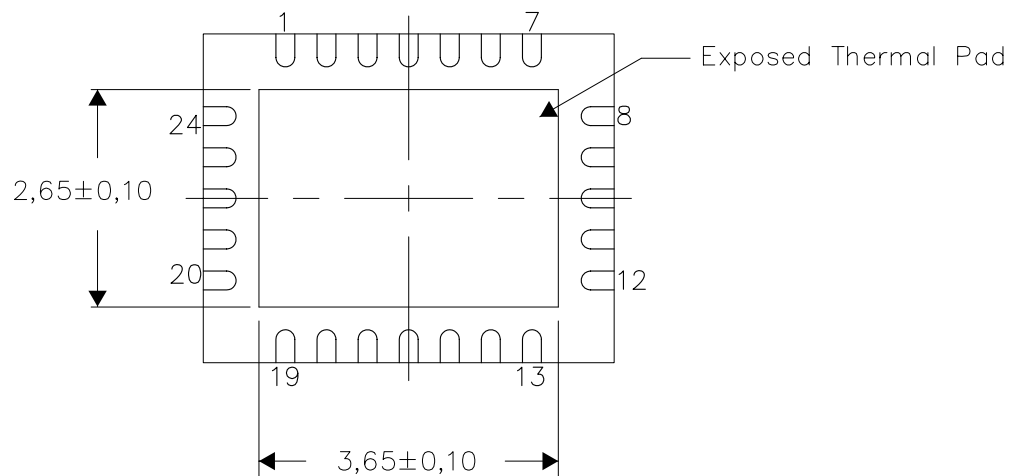

Bottom View

NOTE: All linear dimensions are in millimeters

Exposed Thermal Pad Dimensions

4206360-3/G 04/10

RHF (S-PVQFN-N24)

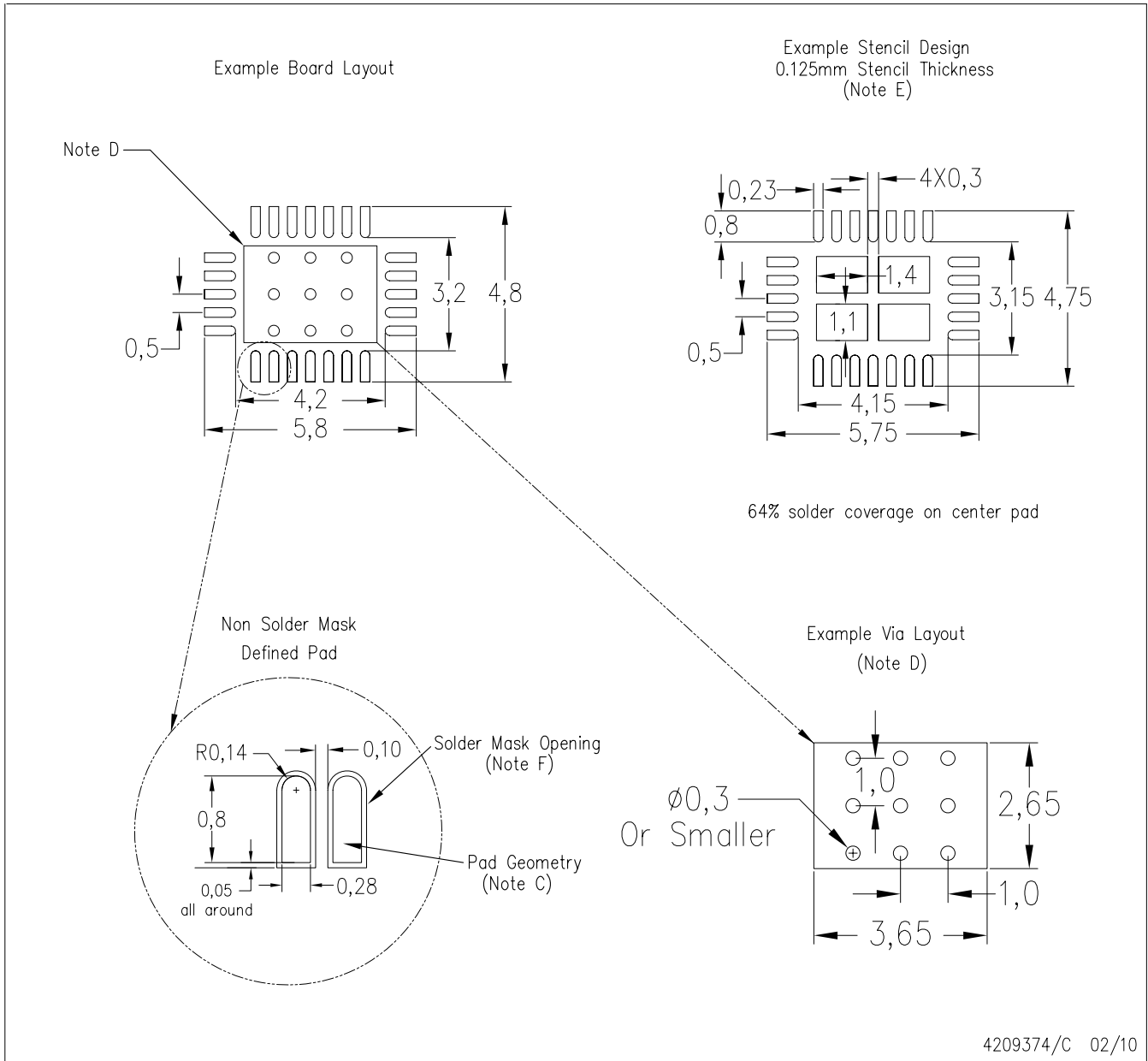

- NOTES:
- A. All linear dimensions are in millimeters.
 - B. This drawing is subject to change without notice.
 - C. Publication IPC-7351 is recommended for alternate designs.
 - D. This package is designed to be soldered to a thermal pad on the board. Refer to Application Note, Quad Flat-Pack Packages, Texas Instruments Literature No. SLUA271, and also the Product Data Sheets for specific thermal information, via requirements, and recommended board layout. These documents are available at www.ti.com <<http://www.ti.com>>.
 - E. Laser cutting apertures with trapezoidal walls and also rounding corners will offer better paste release. Customers should contact their board assembly site for stencil design recommendations. Refer to IPC 7525 for stencil design considerations.
 - F. Customers should contact their board fabrication site for recommended solder mask tolerances and via tenting recommendations for vias placed in thermal pad.

YFF (R-XBGA-N20)

DIE-SIZE BALL GRID ARRAY

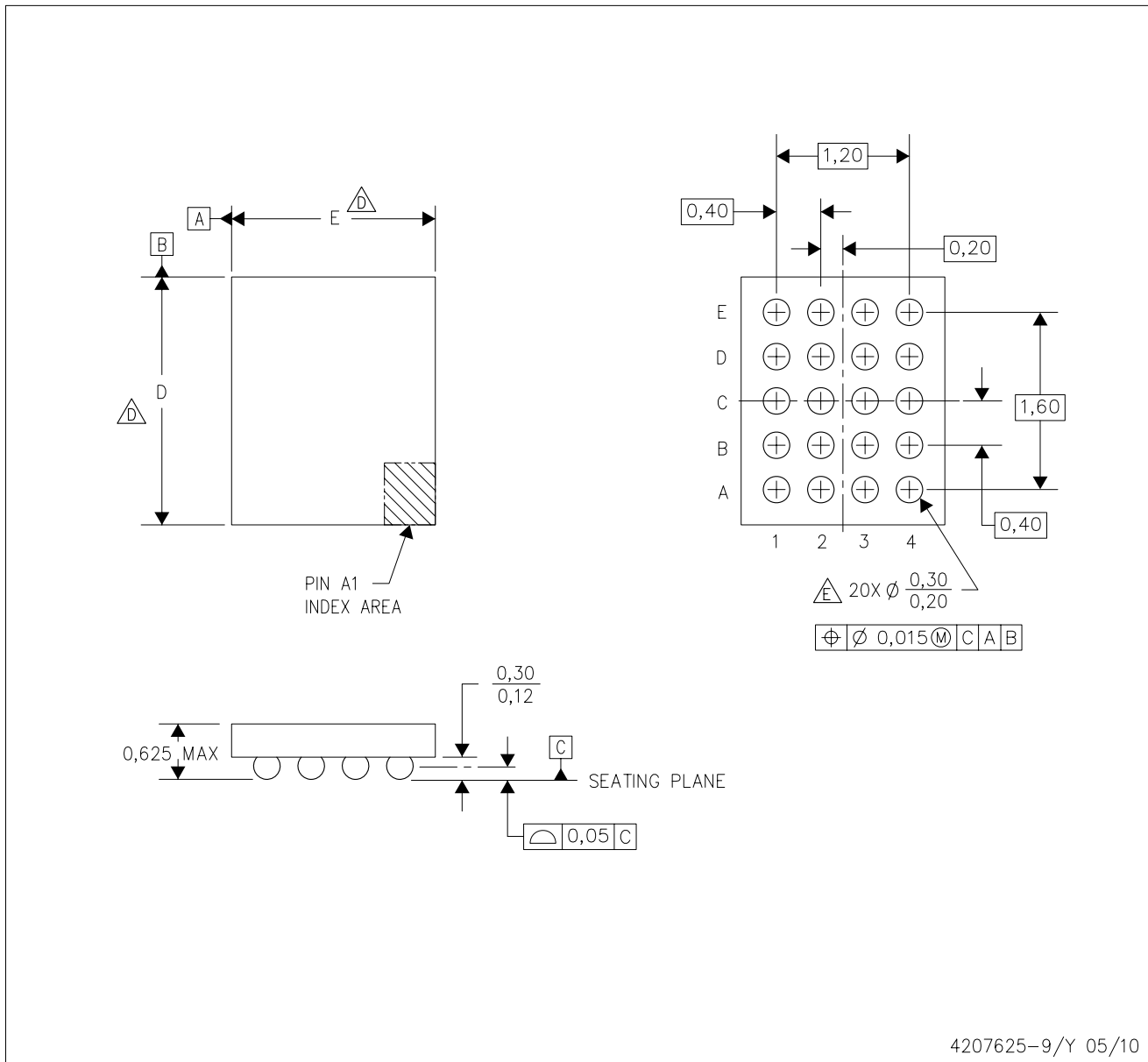

- NOTES:
- A. All linear dimensions are in millimeters. Dimensioning and tolerancing per ASME Y14.5M-1994.
 - B. This drawing is subject to change without notice.
 - C. NanoFree™ package configuration.
 - $\triangle D$ Devices in YFF package can have dimension D ranging from 1.96 to 2.65 mm and dimension E ranging from 1.56 to 2.25mm. To determine the exact package size of a particular device, refer to the device datasheet or contact a local TI representative.
 - E. Reference Product Data Sheet for array population.
5 x 4 matrix pattern is shown for illustration only.
 - F. This package contains Pb-free balls.

NanoFree is a trademark of Texas Instruments.



www.BDTIC.com/TI

IMPORTANT NOTICE

Texas Instruments Incorporated and its subsidiaries (TI) reserve the right to make corrections, modifications, enhancements, improvements, and other changes to its products and services at any time and to discontinue any product or service without notice. Customers should obtain the latest relevant information before placing orders and should verify that such information is current and complete. All products are sold subject to TI's terms and conditions of sale supplied at the time of order acknowledgment.

TI warrants performance of its hardware products to the specifications applicable at the time of sale in accordance with TI's standard warranty. Testing and other quality control techniques are used to the extent TI deems necessary to support this warranty. Except where mandated by government requirements, testing of all parameters of each product is not necessarily performed.

TI assumes no liability for applications assistance or customer product design. Customers are responsible for their products and applications using TI components. To minimize the risks associated with customer products and applications, customers should provide adequate design and operating safeguards.

TI does not warrant or represent that any license, either express or implied, is granted under any TI patent right, copyright, mask work right, or other TI intellectual property right relating to any combination, machine, or process in which TI products or services are used. Information published by TI regarding third-party products or services does not constitute a license from TI to use such products or services or a warranty or endorsement thereof. Use of such information may require a license from a third party under the patents or other intellectual property of the third party, or a license from TI under the patents or other intellectual property of TI.

Reproduction of TI information in TI data books or data sheets is permissible only if reproduction is without alteration and is accompanied by all associated warranties, conditions, limitations, and notices. Reproduction of this information with alteration is an unfair and deceptive business practice. TI is not responsible or liable for such altered documentation. Information of third parties may be subject to additional restrictions.

Resale of TI products or services with statements different from or beyond the parameters stated by TI for that product or service voids all express and any implied warranties for the associated TI product or service and is an unfair and deceptive business practice. TI is not responsible or liable for any such statements.

TI products are not authorized for use in safety-critical applications (such as life support) where a failure of the TI product would reasonably be expected to cause severe personal injury or death, unless officers of the parties have executed an agreement specifically governing such use. Buyers represent that they have all necessary expertise in the safety and regulatory ramifications of their applications, and acknowledge and agree that they are solely responsible for all legal, regulatory and safety-related requirements concerning their products and any use of TI products in such safety-critical applications, notwithstanding any applications-related information or support that may be provided by TI. Further, Buyers must fully indemnify TI and its representatives against any damages arising out of the use of TI products in such safety-critical applications.

TI products are neither designed nor intended for use in military/aerospace applications or environments unless the TI products are specifically designated by TI as military-grade or "enhanced plastic." Only products designated by TI as military-grade meet military specifications. Buyers acknowledge and agree that any such use of TI products which TI has not designated as military-grade is solely at the Buyer's risk, and that they are solely responsible for compliance with all legal and regulatory requirements in connection with such use.

TI products are neither designed nor intended for use in automotive applications or environments unless the specific TI products are designated by TI as compliant with ISO/TS 16949 requirements. Buyers acknowledge and agree that, if they use any non-designated products in automotive applications, TI will not be responsible for any failure to meet such requirements.

Following are URLs where you can obtain information on other Texas Instruments products and application solutions:

Products		Applications	
Amplifiers	amplifier.ti.com	Audio	www.ti.com/audio
Data Converters	dataconverter.ti.com	Automotive	www.ti.com/automotive
DLP® Products	www.dlp.com	Communications and Telecom	www.ti.com/communications
DSP	dsp.ti.com	Computers and Peripherals	www.ti.com/computers
Clocks and Timers	www.ti.com/clocks	Consumer Electronics	www.ti.com/consumer-apps
Interface	interface.ti.com	Energy	www.ti.com/energy
Logic	logic.ti.com	Industrial	www.ti.com/industrial
Power Mgmt	power.ti.com	Medical	www.ti.com/medical
Microcontrollers	microcontroller.ti.com	Security	www.ti.com/security
RFID	www.ti-rfid.com	Space, Avionics & Defense	www.ti.com/space-avionics-defense
RF/IF and ZigBee® Solutions	www.ti.com/lprf	Video and Imaging	www.ti.com/video
		Wireless	www.ti.com/wireless-apps

Mailing Address: Texas Instruments, Post Office Box 655303, Dallas, Texas 75265
Copyright © 2010, Texas Instruments Incorporated

www.BDTIC.com/TI