

## PROGRAMMABLE MAXIMUM DUTY CYCLE PWM CONTROLLER

### FEATURES

- User Programmable Maximum PWM Duty Cycle
- 100-A Startup Current
- Operation to 1 MHz
- Internal Full Cycle Soft Start
- Internal Leading Edge Blanking of Current Sense Signal
- 1-A Totem Pole Output

### DESCRIPTION

The UCC3807 family of high speed, low power integrated circuits contains all of the control and drive circuitry required for off-line and dc-to-dc fixed frequency current mode switching power supplies with minimal external parts count.

These devices are similar to the UCC3800 family, but with the added feature of a user programmable maximum duty cycle. Oscillator frequency and maximum duty cycle are programmed with two resistors and a capacitor. The UCC3807 family also features internal full cycle soft start and internal leading edge blanking of the current sense input.

The UCC3807 family offers a variety of package options, temperature range options, and choice of critical voltage levels. The family has UVLO thresholds and hysteresis levels for off-line and battery powered systems. Thresholds are shown in the table below.

### ORDERING INFORMATION

PART NUMBER	TURN-ON THRESHOLD	TURN-OFF THRESHOLD	PACKAGES
UCCx807-1	7.2 V	6.9 V	J
UCCx807-2	12.5 V	8.3 V	N, D
UCCx807-3	4.3 V	4.1 V	N, D, PW

### BLOCK DIAGRAM

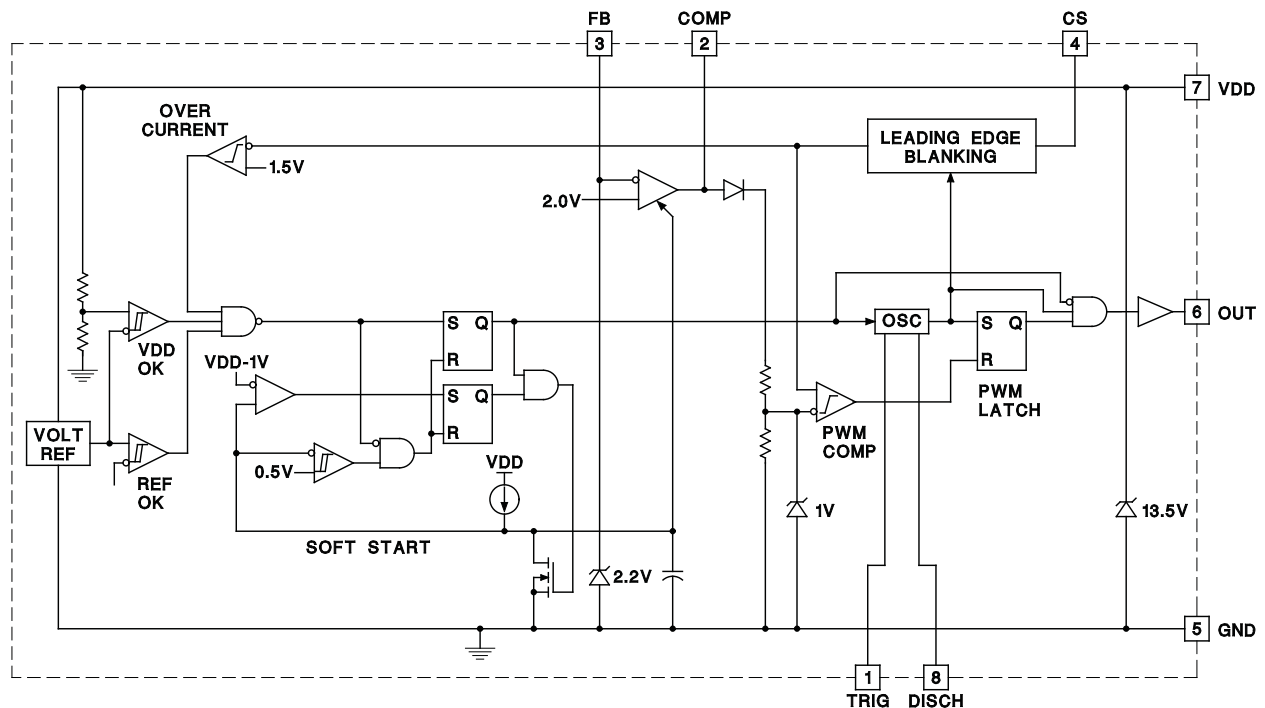

Please be aware that an important notice concerning availability, standard warranty, and use in critical applications of Texas Instruments semiconductor products and disclaimers thereto appears at the end of this data sheet.

## ORDERING INFORMATION

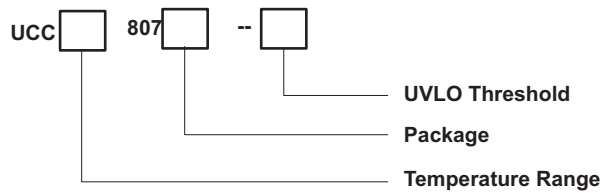

## CONNECTION DIAGRAMS

### DIL-8, SOIC-8 (Top View) J, N or D Packages

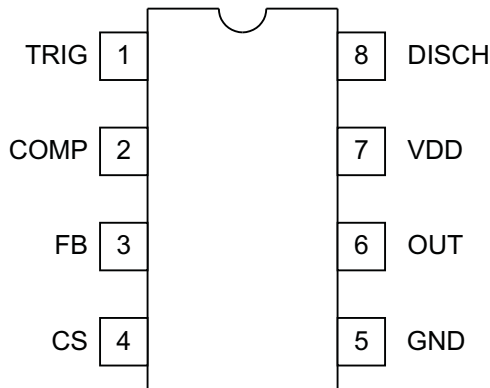

### TSSOP-14 (Top View) PW Package (UCC2807-3 only)

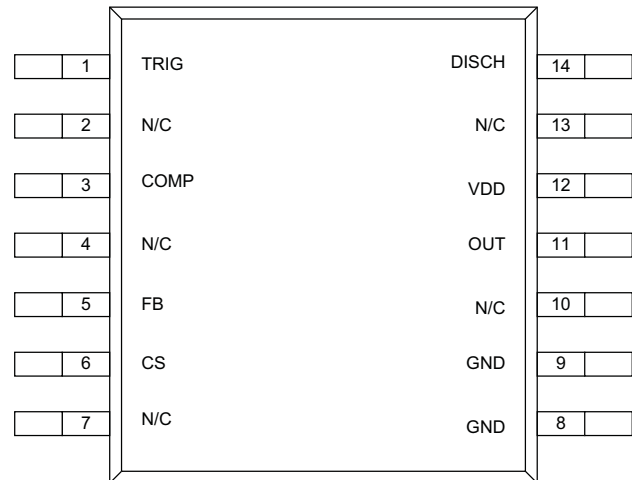

### NOTE

Specified thermal resistance is  $\theta_{JL}$  (junction to lead) on TSSOP-14 pin 8 and 9.

## THERMAL CHARACTERISTICS

over operating free-air temperature range (unless otherwise noted)

PACKAGE	$\theta_{JA}$	$\theta_{JC}$
DIL-8, J	125-160	28 <sup>(1)</sup>
DIL-8, N	110 <sup>(2)</sup>	50
SOIC-8, D	84-160 <sup>(2)</sup>	42
TSSOP-14	132-158 <sup>(3)</sup>	15 <sup>(3)</sup>

- $\theta_{JC}$  data values stated were derived from MIL-STD-1835B. MIL-STD-1835B states that "The baseline values shown are worst case (mean + 2s) for a 60 x 60 mil microcircuit device silicon die and applicable for devices with die sizes up to 14400 square mils. For device die size greater than 14400 square mils use the following values; dual-in-line, 11°C/W; flat pack, 10°C/W; pin grid array, 10°C/W".
- Specified  $\theta_{JC}$  (junction to ambient) is for devices mounted to 5 in2 FR4 PC board with one ounce copper where noted. When resistance range is given, lower values are for 5 in2 aluminum PC board. Test PWB was 0.062 inch thick and typically used 0.635 mm trace widths for power packages and 1.3 mm trace widths for non-power packages with 100 x 100 mil probe land area at the end of each trace.
- Modeled Data. If value range given for  $\theta_{JA}$ , lower value is for 3 x 3 in., 1 ounce internal copper ground plane, higher value is for 1 x 1 inch ground plane. All model data assumes only one trace for each non-fused lead.

**ABSOLUTE MAXIMUM RATINGS<sup>(1)(2)</sup>**

		UNIT
Supply voltage (I <sub>DD</sub> 10 mA)		13.5 V
Supply current		30 mA
OUT current		±1 A
Analog inputs (FB, CS)		–0.3 V to (V <sub>DD</sub> + 0.3 V)
Power dissipation	T <sub>A</sub> +25°C (N or J packages)	1 W
	T <sub>A</sub> +25°C (D package)	0.65 W
Storage temperature		–65°C to 150°C
Junction temperature		–65°C to 150°C
Lead temperature (soldering, 10 sec.)		300°C

- (1) All currents are positive into, negative out of the specified terminal.  
 (2) The UCCx807-2 is designed to be operated in a system that uses as external high voltage source to provide a startup current to a large capacitor from V<sub>DD</sub> to GND. The worse case current from this source should be less than the current needed to run the device in normal operation. The capacitor is needed to provide the reservoir of energy to allow the completion of the startup process before the UVLO voltage is encountered. Once started the converter should be designed so that it is self powered from a controlled voltage source of a lower voltage, one between 9.5 V and 11.5 V. The device is not designed to have the V<sub>DD</sub> clamp active during normal operation. The V<sub>DD</sub> voltage is always less than the clamp voltage. The upper limit of the input voltage is applicable to the whole family of UCCx807-1/-2 or -3.

**ELECTRICAL CHARACTERISTICS**

Unless otherwise stated these specifications apply for T<sub>A</sub> = –55°C to 125°C for UCC1807-1/-2/-3; –40°C to 85°C for UCC2807-1/-2/-3; and 0°C to 70°C for UCC3807-1/-2/-3; V<sub>DD</sub> = 10 V<sup>(1)</sup>, R<sub>A</sub> = 12 kΩ, R<sub>B</sub> = 4.7 kΩ, C<sub>T</sub> = 330 pF, 1.0 μF capacitor from V<sub>DD</sub> to GND, T<sub>A</sub> = T<sub>J</sub>.

PARAMETER	TEST CONDITIONS	MIN	TYP	MAX	UNIT
<b>Oscillator</b>					
Frequency		175	202	228	kHz
Temperature stability	See <sup>(2)</sup>	2.5%			
Amplitude	See <sup>(3)</sup>	1/3V <sub>DD</sub>			V
<b>Error Amplifier</b>					
Input voltage	COMP = 2.0 V	1.95	2.00	2.05	V
Input bias current		–1		1	A
Open loop voltage gain		60	80		dB
COMP sink current	FB = 2.2 V, COMP = 1.0 V	0.3	2.5		mA
COMP source current	FB = 1.3 V, COMP = 4.0 V	–0.2	–0.5		
<b>PWM</b>					
Maximum duty cycle		75%	78%	81%	
Minimum duty cycle	COMP = 0 V			0%	
<b>Current Sense</b>					
Gain	See <sup>(4)</sup>	1.1	1.65	1.8	V/V
Maximum input signal	COMP = 5.0 V <sup>(5)</sup>	0.9	1.0	1.1	V
Input bias current		–200		200	nA
CS blank time		50	100	150	ns
Overcurrent threshold		1.4	1.5	1.6	V
COMP to CS offset	CS = 0 V	0.55	1.1	1.65	

- (1) Adjust V<sub>DD</sub> above the start threshold before setting at 10 V for UCC3807-2.  
 (2) Ensured by design. Not 100% tested in production.  
 (3) Measured at TRIG; signal minimum = 1/3 V<sub>DD</sub>, maximum = 2/3 V<sub>DD</sub>.

$$A \frac{V_{COMP}}{V_{CS}}, 0 \leq V_{CS} \leq 0.8 \text{ V}$$

- (4) Gain is defined by:  
 (5) Parameter measured at trip point of latch with FB at 0 V.

### ELECTRICAL CHARACTERISTICS (continued)

Unless otherwise stated these specifications apply for  $T_A = -55^\circ\text{C}$  to  $125^\circ\text{C}$  for UCC1807-1/-2/-3;  $-40^\circ\text{C}$  to  $85^\circ\text{C}$  for UCC2807-1/-2/-3; and  $0^\circ\text{C}$  to  $70^\circ\text{C}$  for UCC3807-1/-2/-3;  $V_{DD} = 10\text{ V}$ ,  $R_A = 12\text{ k}\Omega$ ,  $R_B = 4.7\text{ k}\Omega$ ,  $C_T = 330\text{ pF}$ ,  $1.0\text{ }\mu\text{F}$  capacitor from  $V_{DD}$  to GND,  $T_A = T_J$ .

PARAMETER	TEST CONDITIONS	MIN	TYP	MAX	UNIT
<b>Output</b>					
OUT low level	$I = 100\text{ mA}$		0.4	1	V
OUT high level	$I = 100\text{ mA}$ , $V_{DD} - \text{OUT}$		0.4	1	
Rise/fall time			20	100	ns
<b>Undervoltage Lockout</b>					
Start threshold	UCCx807-1 <sup>(6)</sup>	6.6	7.2	7.8	V
	UCCx807-2	11.5	12.5	13.5	
	UCCx807-3	4.1	4.3	4.5	
Minimum operating voltage after start	UCCx807-1 <sup>(6)</sup>	6.3	6.9	7.5	V
	UCCx807-2	7.6	8.3	9.0	
	UCCx807-3	3.9	4.1	4.3	
Hysteresis	UCCx807-1	0.1	0.3	0.5	V
	UCCx807-2	3.5	4.2	5.1	
	UCCx807-3	0.1	0.2	0.3	
<b>Soft Start</b>					
COMP rise time	$\text{FB} = 1.8\text{ V}$ , From $0.5\text{ V}$ to $4.0\text{ V}$		4		
<b>Overall</b>					
Startup current	$V_{DD} < \text{Start Threshold (UCCx807-1,-3)}$		0.1	0.2	mA
	$V_{DD} < \text{Start Threshold (UCCx807-2)}$		0.15	0.25	
Operating supply current	$\text{FB} = 0\text{ V}$ , $\text{CS} = 0\text{ V}$ , No Load <sup>(7)</sup>		1.3	2.1	
VDD zener shunt voltage	$I_{DD} = 10\text{ mA}$	12.0	13.5	15.0	V
Shunt to start difference		0.5	10		V

(6) Start Threshold and Zener Shunt thresholds track one another.

(7) Does not include current in external timing RC network.

## PIN DESCRIPTIONS

**COMP:** COMP is the output of the error amplifier and the input of the PWM comparator. The error amplifier in the UCC3807 is a low output impedance, 2 MHz operational amplifier. COMP can both source and sink current. The error amplifier is internally current limited, which allows zero duty cycle by externally forcing COMP to GND.

The UCC3807 family features built-in full cycle soft start. Soft start is implemented as a clamp on the maximum COMP voltage.

**CS:** Current sense input. There are two current sense comparators on the chip, the PWM comparator and an overcurrent comparator.

The UCC3807 also contains a leading edge blanking circuit, which disconnects the external CS signal from the current sense comparator during the 100 ns interval immediately following the rising edge of the signal at the OUT pin. In most applications, no analog filtering is required on CS. Compared to an external RC filtering technique, leading edge blanking provides a smaller effective CS to OUT propagation delay. Note, however, that the minimum non-zero on-time of the OUT signal is directly affected by the leading edge blanking and the CS to OUT propagation delay.

The overcurrent comparator is only intended for fault sensing. Exceeding the overcurrent threshold causes a soft start cycle.

**FB:** The inverting input to the error amplifier. For best stability, keep connections to FB as short as possible and stray capacitance as small as possible.

**GND:** Reference ground and power ground for all functions of the part.

**OUT:** The output of a high current power driver capable of driving the gate of a power MOSFET with peak currents exceeding 1A. OUT is actively held low when VDD is below the UVLO threshold.

The high current power driver consists of MOSFET output devices in a totem pole configuration. This allows the output to switch from VDD to GND. The output stage also provides a very low impedance which minimizes overshoot and undershoot. In most cases, external Schottky clamp diodes are not required.

**TRIG/DISCH:** Oscillator control pins. Trig is the oscillator timing input, which has an RC-type charge/discharge signal controlling the chip's internal oscillator. DISCH is the pin which provides the low impedance discharge path for the external RC network during normal operation. Oscillator frequency and maximum duty cycle are computed as follows:

$$\text{frequency} = \frac{1.4}{R_A \cdot 2R_B \cdot C_T}$$

$$\text{duty cycle} = \frac{R_A \cdot R_B}{R_A \cdot 2R_B}$$

(1)

as shown in [Figure 1](#).

For best performance, keep the lead from  $C_T$  to GND as short as possible. A separate ground connection for  $C_T$  is desirable. The minimum value of  $R_A$  is 10 k $\Omega$ , the minimum value of  $R_B$  is 2.2 k $\Omega$ , and the minimum value of  $C_T$  is 47 pF.

**VDD:** The power input connection for this device. Total VDD current is the sum of quiescent current and the average OUT current. Knowing the operating frequency and the MOSFET gate charge (Qg), average OUT current can be calculated from

$$I_{OUT} = Qg \cdot F, \text{ where } F \text{ is frequency.}$$

To prevent noise problems, bypass VDD to GND with a ceramic capacitor as close to the chip as possible in parallel with an electrolytic capacitor. Once started and operating properly the  $V_{DD}$  voltage should be below the clamp voltage of the device.

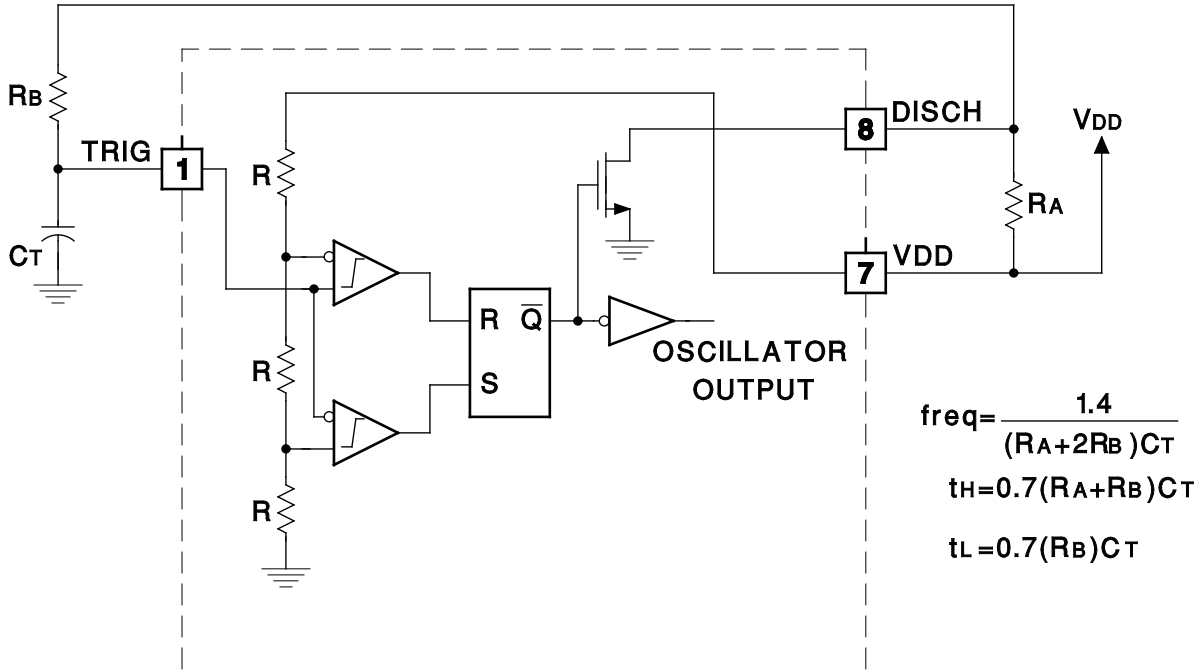

$$\text{freq} = \frac{1.4}{(R_A + 2R_B)C_T}$$

$$t_H = 0.7(R_A + R_B)C_T$$

$$t_L = 0.7(R_B)C_T$$

Figure 1. Oscillator Block Diagram

## APPLICATION INFORMATION

The circuit shown in [Figure 2](#) illustrates the use of the UCC3807 in a typical off-line application. The 100-W, 200-kHz, universal input forward converter produces a regulated 12VDC at 8 Amps. The programmable maximum duty cycle of the UCC3807 allows operation down to 80VRMS and up to 265VRMS with a simple RCD clamp to limit the MOSFET voltage and provide core reset. In this application the maximum duty cycle is set to about 65%. Another feature of the design is the use of a flyback winding on the output filter choke for both bootstrapping and voltage regulation. This method of loop closure eliminates the optocoupler and secondary side regulator, common to most off-line designs, while providing good line and load regulation.

### Winding Information

<b>T1:</b>	
Core	Magnetics Inc. #P-42625-UG (ungapped)
Primary:	28 turns of 2x #26AWG
Secondary:	6 turns of 50x0.2 mm Litz wire
<b>L1:</b>	
Core:	Magnetics Inc. #P-42625-SG-37 (0.020" gap)
Main Winding:	13 turns of 2x #18AWG
Second Winding:	11 turns of #26AWG
<b>Magnetics Inc.</b>	
900 E. Butler Road	
P.O. Box 391	
Butler, PA 16003	
Tel: (412) 282-8282	
Fax: (412) 282-6955	

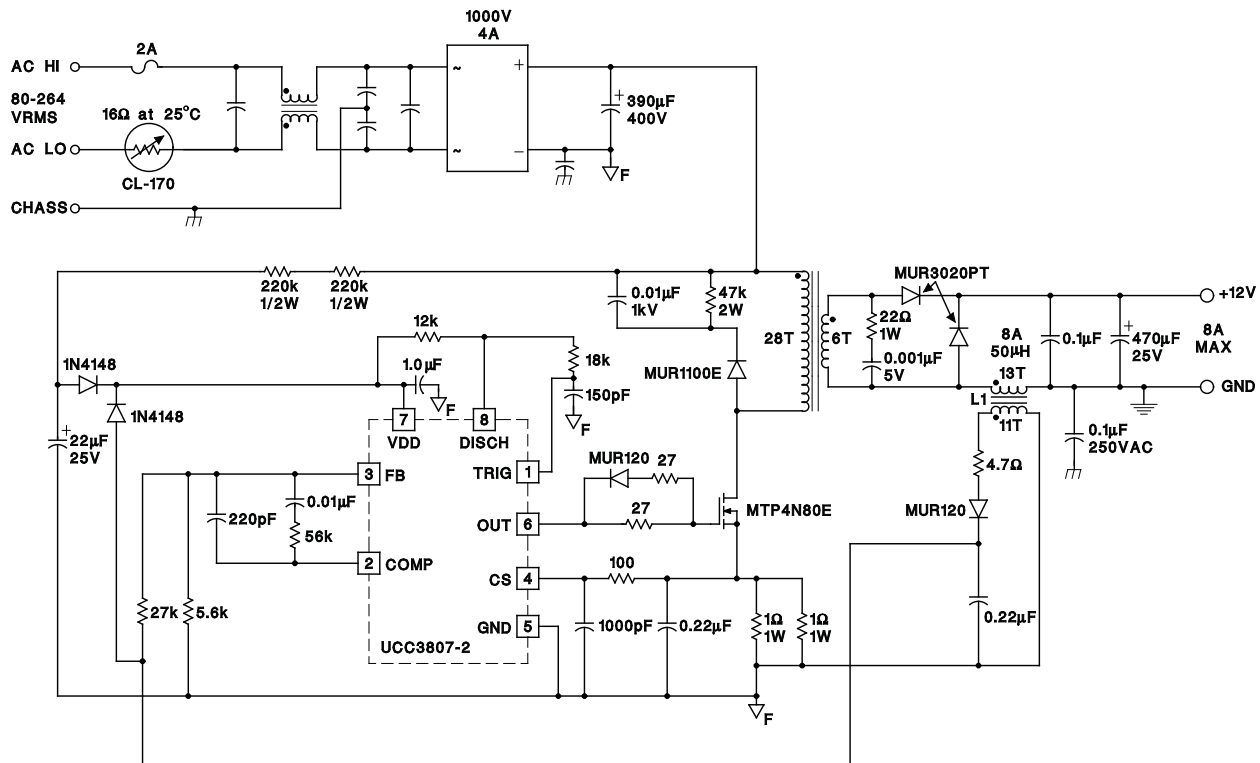

Figure 2. Typical Off-Line Application Using UCC3807-2

**PACKAGING INFORMATION**

Orderable Device	Status <sup>(1)</sup>	Package Type	Package Drawing	Pins	Package Qty	Eco Plan <sup>(2)</sup>	Lead/Ball Finish	MSL Peak Temp <sup>(3)</sup>
UCC2807D-1	ACTIVE	SOIC	D	8	75	Green (RoHS & no Sb/Br)	CU NIPDAU	Level-2-260C-1 YEAR
UCC2807D-1G4	ACTIVE	SOIC	D	8	75	Green (RoHS & no Sb/Br)	CU NIPDAU	Level-2-260C-1 YEAR
UCC2807D-2	ACTIVE	SOIC	D	8	75	Green (RoHS & no Sb/Br)	CU NIPDAU	Level-2-260C-1 YEAR
UCC2807D-2G4	ACTIVE	SOIC	D	8	75	Green (RoHS & no Sb/Br)	CU NIPDAU	Level-2-260C-1 YEAR
UCC2807D-3	ACTIVE	SOIC	D	8	75	Green (RoHS & no Sb/Br)	CU NIPDAU	Level-2-260C-1 YEAR
UCC2807D-3G4	ACTIVE	SOIC	D	8	75	Green (RoHS & no Sb/Br)	CU NIPDAU	Level-2-260C-1 YEAR
UCC2807DTR-1	ACTIVE	SOIC	D	8	2500	Green (RoHS & no Sb/Br)	CU NIPDAU	Level-2-260C-1 YEAR
UCC2807DTR-1G4	ACTIVE	SOIC	D	8	2500	Green (RoHS & no Sb/Br)	CU NIPDAU	Level-2-260C-1 YEAR
UCC2807DTR-2	ACTIVE	SOIC	D	8	2500	Green (RoHS & no Sb/Br)	CU NIPDAU	Level-2-260C-1 YEAR
UCC2807DTR-2G4	ACTIVE	SOIC	D	8	2500	Green (RoHS & no Sb/Br)	CU NIPDAU	Level-2-260C-1 YEAR
UCC2807DTR-3	ACTIVE	SOIC	D	8	2500	Green (RoHS & no Sb/Br)	CU NIPDAU	Level-2-260C-1 YEAR
UCC2807DTR-3G4	ACTIVE	SOIC	D	8	2500	Green (RoHS & no Sb/Br)	CU NIPDAU	Level-2-260C-1 YEAR
UCC2807N-1	ACTIVE	PDIP	P	8	50	Green (RoHS & no Sb/Br)	CU NIPDAU	N / A for Pkg Type
UCC2807N-1G4	ACTIVE	PDIP	P	8	50	Green (RoHS & no Sb/Br)	CU NIPDAU	N / A for Pkg Type
UCC2807N-2	ACTIVE	PDIP	P	8	50	Green (RoHS & no Sb/Br)	CU NIPDAU	N / A for Pkg Type
UCC2807N-2G4	ACTIVE	PDIP	P	8	50	Green (RoHS & no Sb/Br)	CU NIPDAU	N / A for Pkg Type
UCC3807D-1	ACTIVE	SOIC	D	8	75	Green (RoHS & no Sb/Br)	CU NIPDAU	Level-2-260C-1 YEAR
UCC3807D-1G4	ACTIVE	SOIC	D	8	75	Green (RoHS & no Sb/Br)	CU NIPDAU	Level-2-260C-1 YEAR
UCC3807D-2	ACTIVE	SOIC	D	8	75	Green (RoHS & no Sb/Br)	CU NIPDAU	Level-2-260C-1 YEAR
UCC3807D-2G4	ACTIVE	SOIC	D	8	75	Green (RoHS & no Sb/Br)	CU NIPDAU	Level-2-260C-1 YEAR
UCC3807D-3	ACTIVE	SOIC	D	8	75	Green (RoHS & no Sb/Br)	CU NIPDAU	Level-2-260C-1 YEAR
UCC3807D-3G4	ACTIVE	SOIC	D	8	75	Green (RoHS & no Sb/Br)	CU NIPDAU	Level-2-260C-1 YEAR
UCC3807DTR-1	ACTIVE	SOIC	D	8	2500	Green (RoHS & no Sb/Br)	CU NIPDAU	Level-2-260C-1 YEAR
UCC3807DTR-1G4	ACTIVE	SOIC	D	8	2500	Green (RoHS & no Sb/Br)	CU NIPDAU	Level-2-260C-1 YEAR
UCC3807DTR-3	ACTIVE	SOIC	D	8	2500	Green (RoHS & no Sb/Br)	CU NIPDAU	Level-2-260C-1 YEAR



Orderable Device	Status <sup>(1)</sup>	Package Type	Package Drawing	Pins	Package Qty	Eco Plan <sup>(2)</sup>	Lead/Ball Finish	MSL Peak Temp <sup>(3)</sup>
UCC3807DTR-3G4	ACTIVE	SOIC	D	8	2500	Green (RoHS & no Sb/Br)	CU NIPDAU	Level-2-260C-1 YEAR
UCC3807N-1	ACTIVE	PDIP	P	8	50	Green (RoHS & no Sb/Br)	CU NIPDAU	N / A for Pkg Type
UCC3807N-1G4	ACTIVE	PDIP	P	8	50	Green (RoHS & no Sb/Br)	CU NIPDAU	N / A for Pkg Type
UCC3807N-2	ACTIVE	PDIP	P	8	50	Green (RoHS & no Sb/Br)	CU NIPDAU	N / A for Pkg Type
UCC3807N-2G4	ACTIVE	PDIP	P	8	50	Green (RoHS & no Sb/Br)	CU NIPDAU	N / A for Pkg Type
UCC3807N-3	ACTIVE	PDIP	P	8	50	Green (RoHS & no Sb/Br)	CU NIPDAU	N / A for Pkg Type
UCC3807N-3G4	ACTIVE	PDIP	P	8	50	Green (RoHS & no Sb/Br)	CU NIPDAU	N / A for Pkg Type

<sup>(1)</sup> The marketing status values are defined as follows:

**ACTIVE:** Product device recommended for new designs.

**LIFEBUY:** TI has announced that the device will be discontinued, and a lifetime-buy period is in effect.

**NRND:** Not recommended for new designs. Device is in production to support existing customers, but TI does not recommend using this part in a new design.

**PREVIEW:** Device has been announced but is not in production. Samples may or may not be available.

**OBsolete:** TI has discontinued the production of the device.

<sup>(2)</sup> Eco Plan - The planned eco-friendly classification: Pb-Free (RoHS), Pb-Free (RoHS Exempt), or Green (RoHS & no Sb/Br) - please check <http://www.ti.com/productcontent> for the latest availability information and additional product content details.

**TBD:** The Pb-Free/Green conversion plan has not been defined.

**Pb-Free (RoHS):** TI's terms "Lead-Free" or "Pb-Free" mean semiconductor products that are compatible with the current RoHS requirements for all 6 substances, including the requirement that lead not exceed 0.1% by weight in homogeneous materials. Where designed to be soldered at high temperatures, TI Pb-Free products are suitable for use in specified lead-free processes.

**Pb-Free (RoHS Exempt):** This component has a RoHS exemption for either 1) lead-based flip-chip solder bumps used between the die and package, or 2) lead-based die adhesive used between the die and leadframe. The component is otherwise considered Pb-Free (RoHS compatible) as defined above.

**Green (RoHS & no Sb/Br):** TI defines "Green" to mean Pb-Free (RoHS compatible), and free of Bromine (Br) and Antimony (Sb) based flame retardants (Br or Sb do not exceed 0.1% by weight in homogeneous material)

<sup>(3)</sup> MSL, Peak Temp. -- The Moisture Sensitivity Level rating according to the JEDEC industry standard classifications, and peak solder temperature.

**Important Information and Disclaimer:**The information provided on this page represents TI's knowledge and belief as of the date that it is provided. TI bases its knowledge and belief on information provided by third parties, and makes no representation or warranty as to the accuracy of such information. Efforts are underway to better integrate information from third parties. TI has taken and continues to take reasonable steps to provide representative and accurate information but may not have conducted destructive testing or chemical analysis on incoming materials and chemicals. TI and TI suppliers consider certain information to be proprietary, and thus CAS numbers and other limited information may not be available for release.

In no event shall TI's liability arising out of such information exceed the total purchase price of the TI part(s) at issue in this document sold by TI to Customer on an annual basis.

**TAPE AND REEL INFORMATION**



**QUADRANT ASSIGNMENTS FOR PIN 1 ORIENTATION IN TAPE**



\*All dimensions are nominal

Device	Package Type	Package Drawing	Pins	SPQ	Reel Diameter (mm)	Reel Width W1 (mm)	A0 (mm)	B0 (mm)	K0 (mm)	P1 (mm)	W (mm)	Pin1 Quadrant
UCC2807DTR-1	SOIC	D	8	2500	330.0	12.4	6.4	5.2	2.1	8.0	12.0	Q1
UCC2807DTR-2	SOIC	D	8	2500	330.0	12.4	6.4	5.2	2.1	8.0	12.0	Q1
UCC2807DTR-3	SOIC	D	8	2500	330.0	12.4	6.4	5.2	2.1	8.0	12.0	Q1
UCC3807DTR-1	SOIC	D	8	2500	330.0	12.4	6.4	5.2	2.1	8.0	12.0	Q1
UCC3807DTR-3	SOIC	D	8	2500	330.0	12.4	6.4	5.2	2.1	8.0	12.0	Q1

**TAPE AND REEL BOX DIMENSIONS**



\*All dimensions are nominal

Device	Package Type	Package Drawing	Pins	SPQ	Length (mm)	Width (mm)	Height (mm)
UCC2807DTR-1	SOIC	D	8	2500	346.0	346.0	29.0
UCC2807DTR-2	SOIC	D	8	2500	346.0	346.0	29.0
UCC2807DTR-3	SOIC	D	8	2500	346.0	346.0	29.0
UCC3807DTR-1	SOIC	D	8	2500	346.0	346.0	29.0
UCC3807DTR-3	SOIC	D	8	2500	346.0	346.0	29.0

P (R-PDIP-T8)

PLASTIC DUAL-IN-LINE PACKAGE

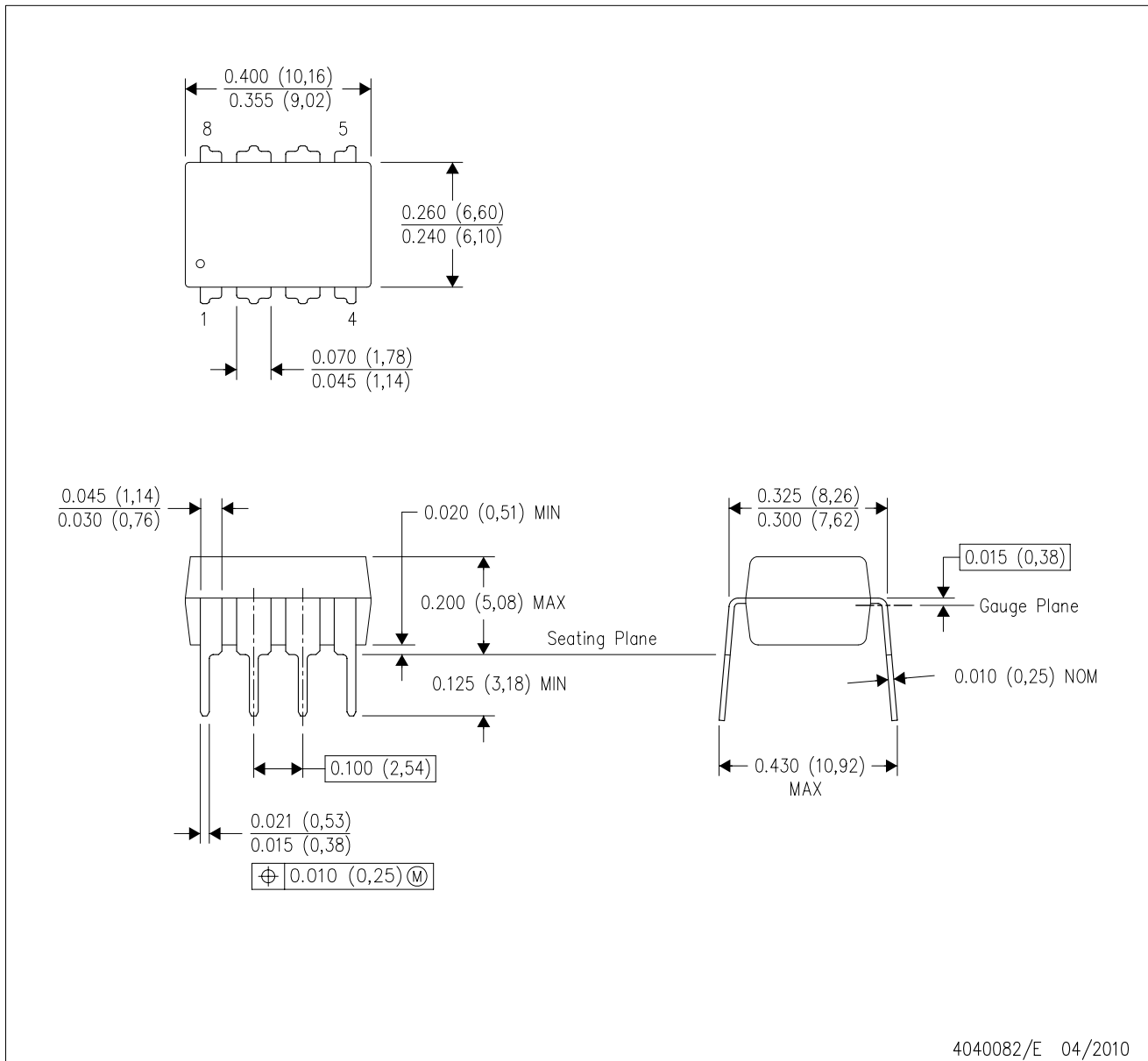

- NOTES:
- A. All linear dimensions are in inches (millimeters).
  - B. This drawing is subject to change without notice.
  - C. Falls within JEDEC MS-001 variation BA.

D (R-PDSO-G8)

PLASTIC SMALL-OUTLINE PACKAGE

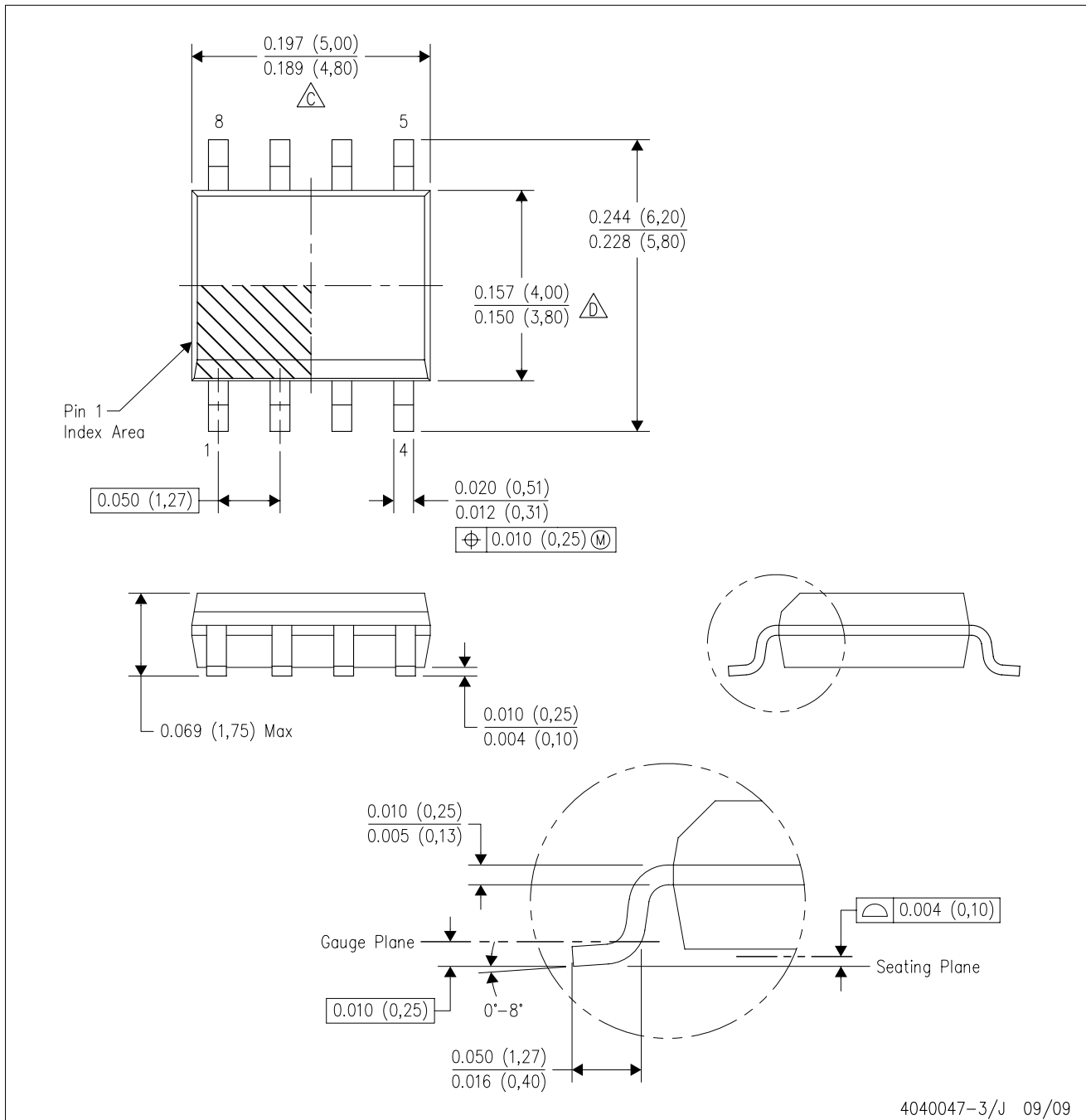

- NOTES:
- A. All linear dimensions are in inches (millimeters).
  - B. This drawing is subject to change without notice.
  - $\triangle C$  Body length does not include mold flash, protrusions, or gate burrs. Mold flash, protrusions, or gate burrs shall not exceed .006 (0,15) per end.
  - $\triangle D$  Body width does not include interlead flash. Interlead flash shall not exceed .017 (0,43) per side.
  - E. Reference JEDEC MS-012 variation AA.

## IMPORTANT NOTICE

Texas Instruments Incorporated and its subsidiaries (TI) reserve the right to make corrections, modifications, enhancements, improvements, and other changes to its products and services at any time and to discontinue any product or service without notice. Customers should obtain the latest relevant information before placing orders and should verify that such information is current and complete. All products are sold subject to TI's terms and conditions of sale supplied at the time of order acknowledgment.

TI warrants performance of its hardware products to the specifications applicable at the time of sale in accordance with TI's standard warranty. Testing and other quality control techniques are used to the extent TI deems necessary to support this warranty. Except where mandated by government requirements, testing of all parameters of each product is not necessarily performed.

TI assumes no liability for applications assistance or customer product design. Customers are responsible for their products and applications using TI components. To minimize the risks associated with customer products and applications, customers should provide adequate design and operating safeguards.

TI does not warrant or represent that any license, either express or implied, is granted under any TI patent right, copyright, mask work right, or other TI intellectual property right relating to any combination, machine, or process in which TI products or services are used. Information published by TI regarding third-party products or services does not constitute a license from TI to use such products or services or a warranty or endorsement thereof. Use of such information may require a license from a third party under the patents or other intellectual property of the third party, or a license from TI under the patents or other intellectual property of TI.

Reproduction of TI information in TI data books or data sheets is permissible only if reproduction is without alteration and is accompanied by all associated warranties, conditions, limitations, and notices. Reproduction of this information with alteration is an unfair and deceptive business practice. TI is not responsible or liable for such altered documentation. Information of third parties may be subject to additional restrictions.

Resale of TI products or services with statements different from or beyond the parameters stated by TI for that product or service voids all express and any implied warranties for the associated TI product or service and is an unfair and deceptive business practice. TI is not responsible or liable for any such statements.

TI products are not authorized for use in safety-critical applications (such as life support) where a failure of the TI product would reasonably be expected to cause severe personal injury or death, unless officers of the parties have executed an agreement specifically governing such use. Buyers represent that they have all necessary expertise in the safety and regulatory ramifications of their applications, and acknowledge and agree that they are solely responsible for all legal, regulatory and safety-related requirements concerning their products and any use of TI products in such safety-critical applications, notwithstanding any applications-related information or support that may be provided by TI. Further, Buyers must fully indemnify TI and its representatives against any damages arising out of the use of TI products in such safety-critical applications.

TI products are neither designed nor intended for use in military/aerospace applications or environments unless the TI products are specifically designated by TI as military-grade or "enhanced plastic." Only products designated by TI as military-grade meet military specifications. Buyers acknowledge and agree that any such use of TI products which TI has not designated as military-grade is solely at the Buyer's risk, and that they are solely responsible for compliance with all legal and regulatory requirements in connection with such use.

TI products are neither designed nor intended for use in automotive applications or environments unless the specific TI products are designated by TI as compliant with ISO/TS 16949 requirements. Buyers acknowledge and agree that, if they use any non-designated products in automotive applications, TI will not be responsible for any failure to meet such requirements.

Following are URLs where you can obtain information on other Texas Instruments products and application solutions:

<b>Products</b>		<b>Applications</b>	
Amplifiers	<a href="http://amplifier.ti.com">amplifier.ti.com</a>	Audio	<a href="http://www.ti.com/audio">www.ti.com/audio</a>
Data Converters	<a href="http://dataconverter.ti.com">dataconverter.ti.com</a>	Automotive	<a href="http://www.ti.com/automotive">www.ti.com/automotive</a>
DLP® Products	<a href="http://www.dlp.com">www.dlp.com</a>	Communications and Telecom	<a href="http://www.ti.com/communications">www.ti.com/communications</a>
DSP	<a href="http://dsp.ti.com">dsp.ti.com</a>	Computers and Peripherals	<a href="http://www.ti.com/computers">www.ti.com/computers</a>
Clocks and Timers	<a href="http://www.ti.com/clocks">www.ti.com/clocks</a>	Consumer Electronics	<a href="http://www.ti.com/consumer-apps">www.ti.com/consumer-apps</a>
Interface	<a href="http://interface.ti.com">interface.ti.com</a>	Energy	<a href="http://www.ti.com/energy">www.ti.com/energy</a>
Logic	<a href="http://logic.ti.com">logic.ti.com</a>	Industrial	<a href="http://www.ti.com/industrial">www.ti.com/industrial</a>
Power Mgmt	<a href="http://power.ti.com">power.ti.com</a>	Medical	<a href="http://www.ti.com/medical">www.ti.com/medical</a>
Microcontrollers	<a href="http://microcontroller.ti.com">microcontroller.ti.com</a>	Security	<a href="http://www.ti.com/security">www.ti.com/security</a>
RFID	<a href="http://www.ti-rfid.com">www.ti-rfid.com</a>	Space, Avionics & Defense	<a href="http://www.ti.com/space-avionics-defense">www.ti.com/space-avionics-defense</a>
RF/IF and ZigBee® Solutions	<a href="http://www.ti.com/lprf">www.ti.com/lprf</a>	Video and Imaging	<a href="http://www.ti.com/video">www.ti.com/video</a>
		Wireless	<a href="http://www.ti.com/wireless-apps">www.ti.com/wireless-apps</a>

Mailing Address: Texas Instruments, Post Office Box 655303, Dallas, Texas 75265  
Copyright © 2010, Texas Instruments Incorporated

[www.BDTIC.com/TI](http://www.BDTIC.com/TI)