

## BICMOS ADVANCED PHASE-SHIFT PWM CONTROLLER

### FEATURES

- Programmable Output Turn-on Delay
- Adaptive Delay Set
- Bidirectional Oscillator Synchronization
- Voltage-Mode, Peak Current-Mode, or Average Current-Mode Control
- Programmable Softstart/Softstop and Chip Disable via a Single Pin
- 0% to 100% Duty-Cycle Control
- 7-MHz Error Amplifier
- Operation to 1 MHz
- Typical 5-mA Operating Current at 500 kHz
- Very Low 150- $\mu$ A Current During UVLO

### DESCRIPTION

The UCC3895 is a phase-shift PWM controller that implements control of a full-bridge power stage by phase shifting the switching of one half-bridge with respect to the other. It allows constant frequency pulse-width modulation in conjunction with resonant zero-voltage switching to provide high efficiency at high frequencies. The part can be used either as a voltage-mode or current-mode controller.

While the UCC3895 maintains the functionality of the UC3875/6/7/8 family and UC3879, it improves on that controller family with additional features such as enhanced control logic, adaptive delay set, and shutdown capability. Since it is built using the BCDMOS process, it operates with dramatically less supply current than its bipolar counterparts. The UCC3895 can operate with a maximum clock frequency of 1 MHz.

### APPLICATIONS

- Phase-Shifted Full-Bridge Converters
- Off-Line, Telecom, Datacom and Servers
- Distributed Power Architecture
- High-Density Power Modules

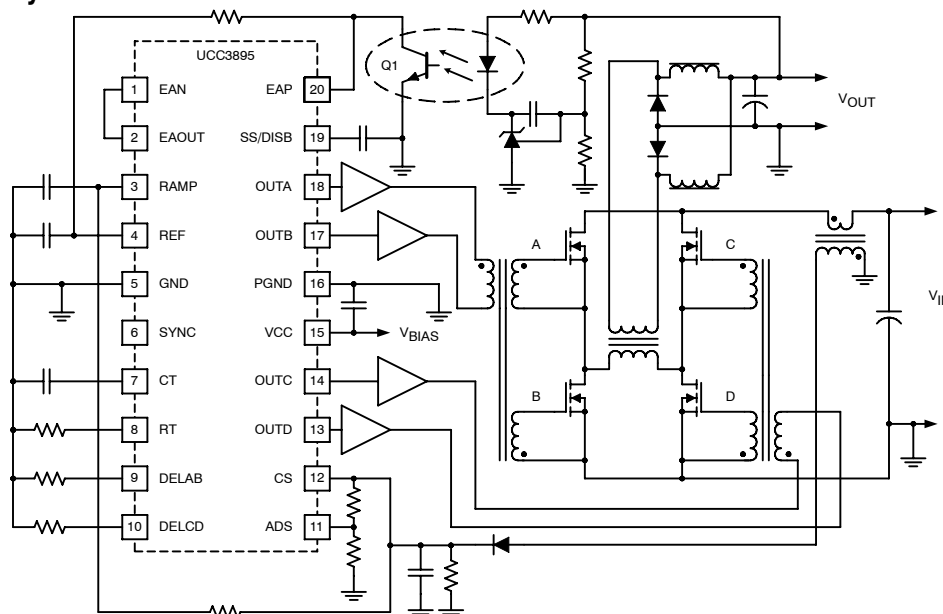

UDG-03123



Please be aware that an important notice concerning availability, standard warranty, and use in critical applications of Texas Instruments semiconductor products and disclaimers thereto appears at the end of this data sheet.

PRODUCTION DATA information is current as of publication date. Products conform to specifications per the terms of Texas Instruments standard warranty. Production processing does not necessarily include testing of all parameters.

Copyright © 2008 - 2010, Texas Instruments Incorporated

**UCC1895**  
**UCC2895**  
**UCC3895**

SLUS1570 - DECEMBER 1999 - REVISED APRIL 2010

**ORDERING INFORMATION**

T <sub>A</sub>	PACKAGED DEVICES					
	SOIC-20(DW) <sup>(1)</sup>	PDIP-20(N)	TSSOP-20(PW) <sup>(1)</sup>	PLCC-20(Q) <sup>(1)</sup>	CLCC-20(L)	CDIP-20(J)
-55°C to 125°C					UCC1895L	UCC1895J
-40°C to 85°C	UCC2895DW	UCC2895N	UCC2895PW	UCC2895Q		
0°C to 70°C	UCC3895DW	UCC3895N	UCC3895PW	UCC3895Q		

<sup>(1)</sup> The DW, PW and Q packages are available taped and reeled. Add TR suffix to device type (e.g. UCC2895DWTR) to order quantities of 2000 devices per reel for DW.

**PW and DW PACKAGE  
(TOP VIEW)**

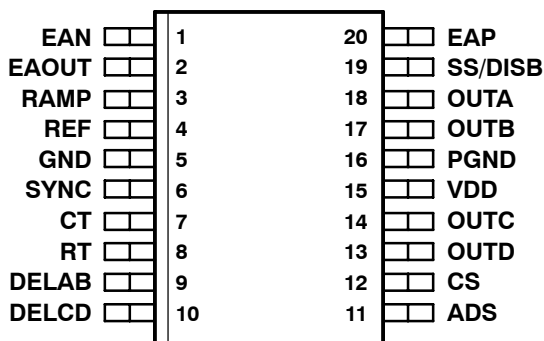

**N and J PACKAGE  
(TOP VIEW)**

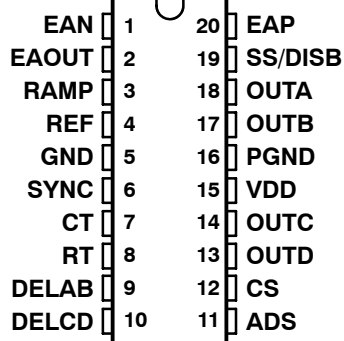

**Q and L PACKAGE  
(TOP VIEW)**

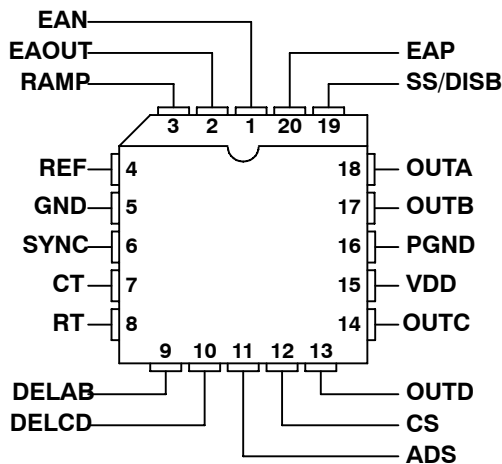

PART	T <sub>JA</sub>	T <sub>JC</sub>	UNIT
UCC2895DW	90	25	°C/W
UCC2895N	80	35	
UCC2895PW	125	14	
UCC2895Q	75	34	
UCC1895J	85	28	
UCC1895L	80	20	

## ABSOLUTE MAXIMUM RATINGS

All voltage values are with respect to the network ground terminal unless otherwise noted. <sup>(2)</sup>

		UCCx895N	UNIT
Supply voltage	( $I_{DD} < 10 \text{ mA}$ )	17	V
Supply current		30	mA
Reference current		15	
Output current		100	
Analog inputs	EAP, EAN, EAOUT, RAMP, SYNC, ADS, CS, SS/DISB	-0.3 V to REF+0.3 V	V
Drive outputs	OUTA, OUTB, OUTC, OUTD	-0.3 V to VCC + 0.3 V	
Power dissipation at $T_A = 25^\circ\text{C}$	DW-20 package	650	mW
	N-20 package	1	W
Storage temperature range, $T_{stg}$		-65 to 150	°C
Junction temperature range, $T_J$		-55 to 150	
Lead temperature 1,6 mm (1/16 inch) from case for 10 seconds		300	

<sup>(2)</sup> Stresses beyond those listed under absolute maximum ratings may cause permanent damage to the device. These are stress ratings only, and functional operation of the device at these or any other conditions beyond those indicated under "recommended operating conditions" is not implied. Exposure to Absolute Maximum Rated conditions for extended periods may affect device reliability

## RECOMMENDED OPERATING CONDITIONS<sup>(3)</sup>

	MIN	TYP	MAX	UNIT
Supply voltage, $V_{DD}$	10		16.5	V
Supply voltage bypass capacitor, $V_{DD}^{(1)}$		$10 \times C_{REF}$		μF
Reference bypass capacitor, $C_{REF}^{(2)}$ (UCC1895)	0.1		1.0	
Reference bypass capacitor, $C_{REF}^{(2)}$ (UCC2895, UCC3895)	0.1		4.7	
Timing capacitor, $C_T$ (for 500 kHz switching frequency)		220		pF
Timing resistor, $R_T$ (for 500 kHz switching frequency)		82		kΩ
Delay resistor $R_{DEL\_AB}$ , $R_{DEL\_CD}$	2.5		40	
Operating junction temperature, $T_J^{(4)}$	-55		125	°C

<sup>(1)</sup> The  $V_{DD}$  capacitor should be a low ESR, ESL ceramic capacitor located directly across the VDD and PGND pins. A larger bulk capacitor should be located as physically close as possible to the  $V_{DD}$  pins.

<sup>(2)</sup> The  $V_{REF}$  capacitor should be a low ESR, ESL ceramic capacitor located directly across the REF and GND pins. If a larger capacitor is desired for the  $V_{REF}$  then it should be located near the  $V_{REF}$  cap and connected to the  $V_{REF}$  pin with a resistor of 51 Ω or greater. The bulk capacitor on  $V_{DD}$  must be a factor of 10 greater than the total  $V_{REF}$  capacitance.

<sup>(3)</sup> It is recommended that there be a single point grounded between GND and PGND directly under the device. There should be a separate ground plane associated with the GND pin and all components associated with pins 1 through 12 plus 19 and 20 be located over this ground plane. Any connections associated with these pins to ground should be connected to this ground plane.

<sup>(4)</sup> It is not recommended that the device operate under conditions beyond those specified in this table for extended periods of time.

**UCC1895**  
**UCC2895**  
**UCC3895**

SLUS1570 - DECEMBER 1999 - REVISED APRIL 2010

**ELECTRICAL CHARACTERISTICS**  $V_{DD} = 12\text{ V}$ ,  $R_T = 82\text{ k}\Omega$ ,  $C_T = 220\text{ pF}$ ,  $R_{DELAB} = 10\text{ k}\Omega$ ,  $R_{DELCD} = 10\text{ k}\Omega$ ,  $C_{REF} = 0.1\text{ }\mu\text{F}$ ,  $C_{VDD} = 0.1\text{ }\mu\text{F}$  and no load on the outputs,  $T_A = T_J$ ,  $T_A = 0^\circ\text{C}$  to  $70^\circ\text{C}$  for UCC3895x,  $T_A = -40^\circ\text{C}$  to  $85^\circ\text{C}$  for UCC2895x and  $T_A = -55^\circ\text{C}$  to  $125^\circ\text{C}$  for the UCC1895x. (unless otherwise noted)

PARAMETER		TEST CONDITIONS	MIN	TYP	MAX	UNITS
<b>UVLO (UNDERVOLTAGE LOCKOUT)</b>						
UVLO <sub>(on)</sub>	Start-up voltage threshold		10.2	11	11.8	V
UVLO <sub>(off)</sub>	Minimum operating voltage after start-up		8.2	9	9.8	
UVLO <sub>(hys)</sub>	Hysteresis		1.0	2.0	3.0	
<b>SUPPLY</b>						
I <sub>START</sub>	Start-up current	V <sub>DD</sub> = 8 V		150	250	$\mu\text{A}$
I <sub>DD</sub>	Operating current			5	6	mA
V <sub>DD_CLAMP</sub>	V <sub>DD</sub> clamp voltage	I <sub>DD</sub> = 10 mA	16.5	17.5	18.5	V
<b>VOLTAGE REFERENCE</b>						
V <sub>REF</sub>	Output voltage	T <sub>J</sub> = 25°C	4.94	5.00	5.06	V
		10 V < V <sub>DD</sub> < V <sub>DD_CLAMP</sub> , 0 mA < I <sub>REF</sub> < 5 mA, temperature	4.85	5	5.15	
I <sub>SC</sub>	Short circuit current	REF = 0 V, T <sub>J</sub> = 25°C	10	20		mA
<b>ERROR AMPLIFIER</b>						
	Common-mode input voltage range		-0.1		3.6	V
V <sub>IO</sub>	Offset voltage		-7		7	mV
I <sub>BIAS</sub>	Input bias current (EAP, EAN)		-1		1	$\mu\text{A}$
EAOUT <sub>_VOH</sub>	High-level output voltage	EAP-EAN = 500 mV, I <sub>EAOUT</sub> = -0.5 mA	4.0	4.5	5.0	V
EAOUT <sub>_VOL</sub>	Low-level output voltage	EAP-EAN = -500 mV, I <sub>EAOUT</sub> = 0.5 mA	0	0.2	0.4	
I <sub>SOURCE</sub>	Error amplifier output source current	EAP-EAN = 500 mV, EAOUT = 2.5 V	1.0	1.5		mA
I <sub>SINK</sub>	Error amplifier output sink current	EAP-EAN = -500 mV, EAOUT = 2.5 V	2.5	4.5		
A <sub>VOL</sub>	Open-loop dc gain		75	85		dB
GBW	Unity gain bandwidth <sup>(1)</sup>		5.0	7.0		MHz
	Slew rate <sup>(1)</sup>	1 V < EAN < 0 V, EAP = 500 mV 0.5 V < EAOUT < 3.0 V	1.5	2.2		V/ $\mu\text{s}$
	No-load comparator turn-off threshold		0.45	0.50	0.55	V
	No-load comparator turn-on threshold		0.55	0.60	0.69	
	No-load comparator hysteresis		0.035	0.10	0.165	
<b>OSCILLATOR</b>						
f <sub>OSC</sub>	Frequency	T <sub>J</sub> = 25°C	473	500	527	kHz
	Frequency total variation <sup>(1)</sup>	Over line, temperature		2.5%	5%	
V <sub>IH_SYNC</sub>	SYNC input threshold, SYNC		2.05	2.10	2.40	V
V <sub>OH_SYNC</sub>	High-level output voltage, SYNC	I <sub>SYNC</sub> = -400 $\mu\text{A}$ , V <sub>CT</sub> = 2.6 V	4.1	4.5	5.0	
V <sub>OL_SYNC</sub>	Low-level output voltage, SYNC	I <sub>SYNC</sub> = 100 $\mu\text{A}$ , V <sub>CT</sub> = 0.0 V	0.0	0.5	1.0	
	Sync output pulse width	LOAD <sub>SYNC</sub> = 3.9 k $\Omega$ and 30 pF in parallel		85	135	ns
V <sub>RT</sub>	Timing resistor voltage		2.9	3	3.1	V
V <sub>CT(peak)</sub>	Timing capacitor peak voltage		2.25	2.35	2.55	
V <sub>CT(valley)</sub>	Timing capacitor valley voltage		0.0	0.2	0.4	

<sup>(1)</sup> Ensured by design. Not production tested.

**ELECTRICAL CHARACTERISTICS**  $V_{DD} = 12\text{ V}$ ,  $R_T = 82\text{ k}\Omega$ ,  $C_T = 220\text{ pF}$ ,  $R_{DELAB} = 10\text{ k}\Omega$ ,  $R_{DELCD} = 10\text{ k}\Omega$ ,  $C_{REF} = 0.1\text{ }\mu\text{F}$ ,  $C_{VDD} = 0.1\text{ }\mu\text{F}$  and no load on the outputs,  $T_A = T_J$ .  $T_A = 0^\circ\text{C}$  to  $70^\circ\text{C}$  for UCC3895x,  $T_A = -40^\circ\text{C}$  to  $85^\circ\text{C}$  for UCC2895x and  $T_A = -55^\circ\text{C}$  to  $125^\circ\text{C}$  for the UCC1895x. (unless otherwise noted)

PARAMETER		TEST CONDITIONS		MIN	TYP	MAX	UNITS
<b>CURRENT SENSE</b>							
$I_{CS(bias)}$	Current sense bias current	$0\text{ V} < CS < 2.5\text{ V}$ ,	$0\text{ V ADS} < 2.5\text{ V}$	-4.5		20	$\mu\text{A}$
	Peak current threshold			1.90	2.00	2.10	V
	Overcurrent threshold			2.4	2.5	2.6	V
	Current sense to output delay	$0\text{V} \leq CS \leq 2.3\text{ V}$ ,	DELAB=DELCD=REF		75	110	ns
<b>SOFT-START/SHUTDOWN</b>							
$I_{SOURCE}$	Softstart source current	SS/DISB = 3.0 V,	CS = 1.9 V	-40	-35	-30	$\mu\text{A}$
$I_{SINK}$	Softstart sink current	SS/DISB = 3.0 V,	CS = 2.6 V	325	350	375	$\mu\text{A}$
	Softstart/disable comparator threshold			0.44	0.50	0.56	V
<b>ADAPTIVE DELAY SET (ADS)</b>							
DELAB/DELCD output voltage		ADS = CS = 0 V		0.45	0.50	0.55	V
		ADS = 0 V,	CS = 2.0 V	1.9	2.0	2.1	V
$t_{DELAY}$	Output delay <sup>(1)(3)</sup>	ADS = CS = 0 V		450	560	620	ns
	ADS bias current	$0\text{ V} < ADS < 2.5\text{ V}$ ,	$0\text{ V} < CS < 2.5\text{ V}$	-20		20	$\mu\text{A}$
<b>OUTPUT</b>							
$V_{OH}$	High-level output voltage (all outputs)	$I_{OUT} = -10\text{ mA}$ , VDD to output			250	400	mV
$V_{OL}$	Low-level output voltage (all outputs)	$I_{OUT} = 10\text{ mA}$			150	250	mV
$t_R$	Rise time <sup>(1)</sup>	$C_{LOAD} = 100\text{ pF}$			20	35	ns
$t_F$	Fall time <sup>(1)</sup>	$C_{LOAD} = 100\text{ pF}$			20	35	ns

(1) Ensured by design. Not production tested.

(2) Minimum phase shift is defined as:

$$\Phi = 180 \times \frac{t_f(OUTC) - t_f(OUTA)}{t_{PERIOD}} \quad \text{or} \quad \Phi = 180 \times \frac{t_f(OUTC) - t_f(OUTB)}{t_{PERIOD}} \quad \text{where}$$

$t_f(OUTA)$  = falling edge of OUTA signal,  $t_f(OUTB)$  = falling edge of OUTB signal

$t_f(OUTC)$  = falling edge of OUTC signal,  $t_f(OUTD)$  = falling edge of OUTD signal

$t_{PERIOD}$  = period of OUTA or OUTB signal

(3) Output delay is measured between OUTA/OUTB or OUTC/OUTD. Output delay is defined as shown below where:

$t_f(OUTA)$  = falling edge of OUTA signal,  $t_r(OUTB)$  = rising edge of OUTB signal

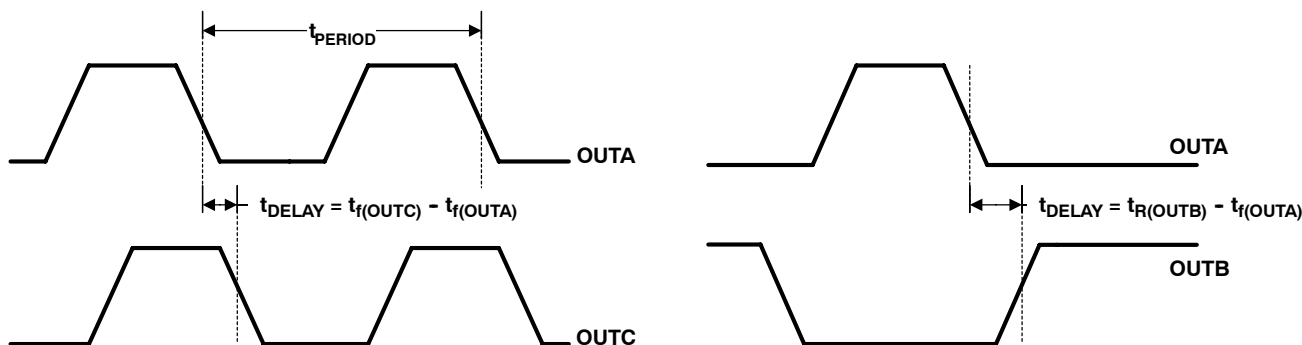

Same applies to OUTB and OUTD

Same applies to OUTC and OUTD

**UCC1895**  
**UCC2895**  
**UCC3895**

SLUS157O - DECEMBER 1999 - REVISED APRIL 2010

**ELECTRICAL CHARACTERISTICS**  $V_{DD} = 12\text{ V}$ ,  $R_T = 82\text{ k}\Omega$ ,  $C_T = 220\text{ pF}$ ,  $R_{DELAB} = 10\text{ k}\Omega$ ,  $R_{DELCD} = 10\text{ k}\Omega$ ,  $C_{REF} = 0.1\text{ }\mu\text{F}$ ,  $C_{VDD} = 0.1\text{ }\mu\text{F}$  and no load on the outputs,  $T_A = T_J$ .  $T_A = 0^\circ\text{C}$  to  $70^\circ\text{C}$  for UCC3895x,  $T_A = -40^\circ\text{C}$  to  $85^\circ\text{C}$  for UCC2895x and  $T_A = 55^\circ\text{C}$  to  $125^\circ\text{C}$  for the UCC1895x. (unless otherwise noted)

PARAMETER		TEST CONDITIONS		MIN	TYP	MAX	UNITS
<b>PWM COMPARATOR</b>							
EAOUT to RAMP input offset voltage		RAMP = 0 V,	DELAB=DELCD=REF	0.72	0.85	1.05	V
Minimum phase shift <sup>(2)</sup> (OUTA to OUTC, OUTB to OUTD)		RAMP = 0 V	EAOUT = 650 mV	.0%	.85%	1.4%	
$t_{DELAY}$	Delay <sup>(3)</sup> (RAMP to OUTC, RAMP to OUTD)	0 V < RAMP < 2.5 V,	EAOUT = 1.2 V, DELAB=DELCD=REF		70	120	ns
$I_{R(bias)}$	RAMP bias current	RAMP < 5 V,	CT = 2.2 V	-5		5	$\mu\text{A}$
$I_{R(sink)}$	RAMP sink current	RAMP = 5 V,	CT = 2.6 V	12	19		mA

**TERMINAL FUNCTIONS**

TERMINAL NAME	NO.	I/O	DESCRIPTION
ADS	11	I	Adaptive delay set. Sets the ratio between the maximum and minimum programmed output delay dead time.
CS	12	I	Current sense input for cycle-by-cycle current limiting and for over-current comparator.
CT	7	I	Oscillator timing capacitor for programming the switching frequency. The UCC3895's oscillator charges CT via a programmed current.
DELAB	9	I	Delay programming between complementary outputs. DELAB programs the dead time between switching of output A and output B.
DELCD	10	I	Delay programming between complementary outputs. DELCD programs the dead time between switching of output C and output D.
EAOUT	2	I/O	Error amplifier output.
EAP	20	I	Non-inverting input to the error amplifier. Keep below 3.6 volts for proper operation.
EAN	1	I	Inverting input to the error amplifier. Keep below 3.6 volts for proper operation.
GND	5	-	Chip ground for all circuits except the output stages.
OUTA	18	O	The four outputs are 100-mA complementary MOS drivers, and are optimized to drive FET driver circuits such as UCC27424 or gate drive transformers.
OUTB	17	O	
OUTC	14	O	
OUTD	13	O	
PGND	16	-	Output stage ground.
RAMP	3	I	Inverting input of the PWM comparator.
REF	4	O	5 V, $\pm 1.2\%$ , 5 mA voltage reference. For best performance, bypass with a 0.1- $\mu\text{F}$ low ESR, low ESL capacitor to ground. Do not use more than 4.7 $\mu\text{F}$ of total capacitance on this pin.
RT	8	I	Oscillator timing resistor for programming the switching frequency.
SS/DISB	19	I	Soft-start/disable. This pin combines the two independent functions.
SYNC	6	I/O	Oscillator synchronization. This pin is bidirectional.
VDD	15	I	Power supply input pin. VDD must be bypassed with a minimum of a 1.0- $\mu\text{F}$ low ESR, low ESL capacitor to ground. The addition of a 10- $\mu\text{F}$ low ESR, low ESL between VDD and PGND is recommended.

BLOCK DIAGRAM

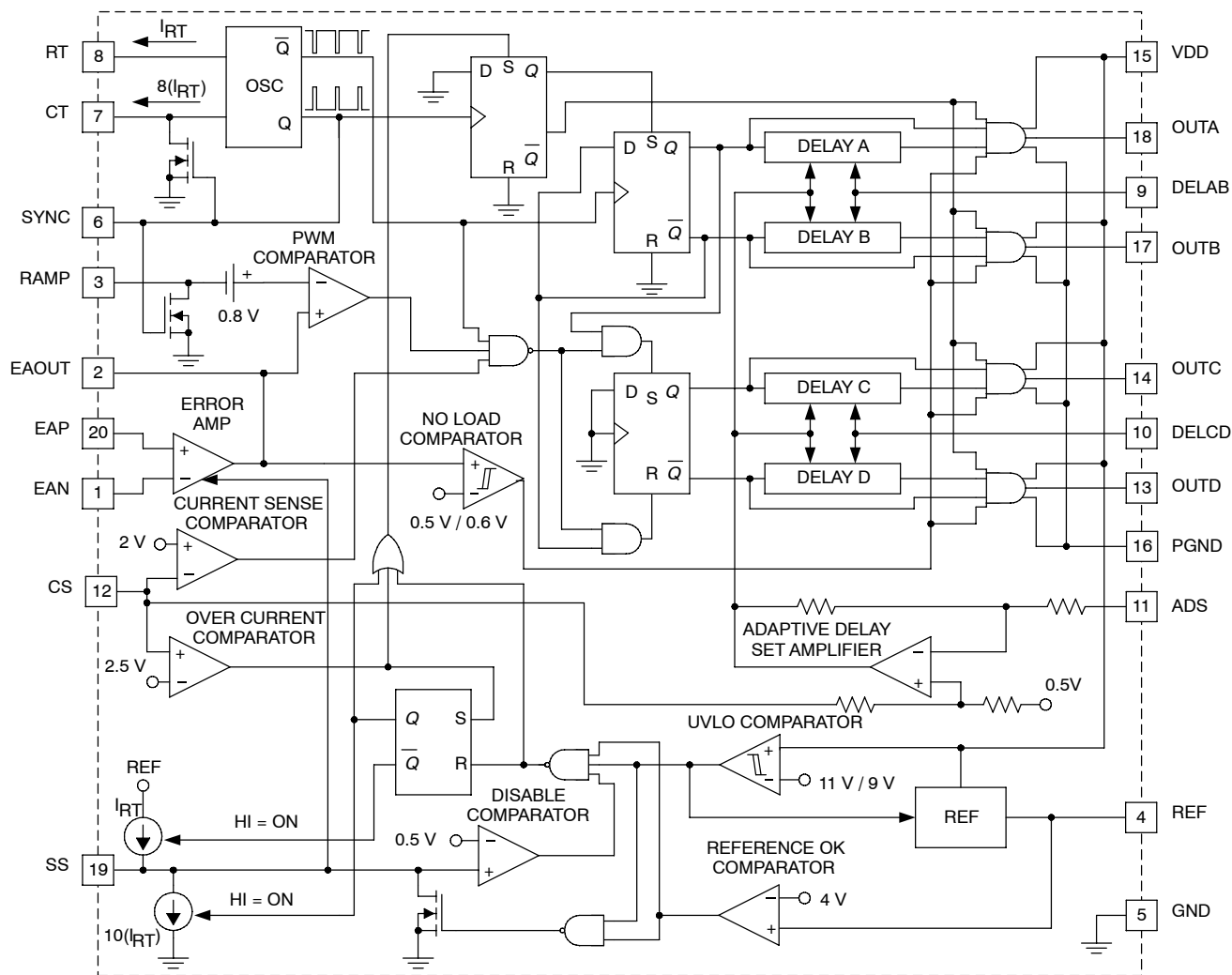

UDG-98140

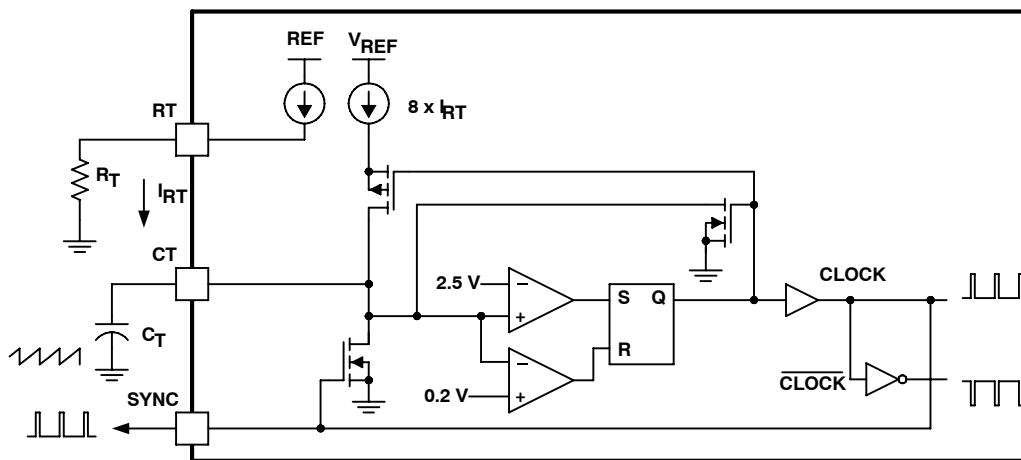

UDG-03135

Figure 1. Oscillator Block Diagram

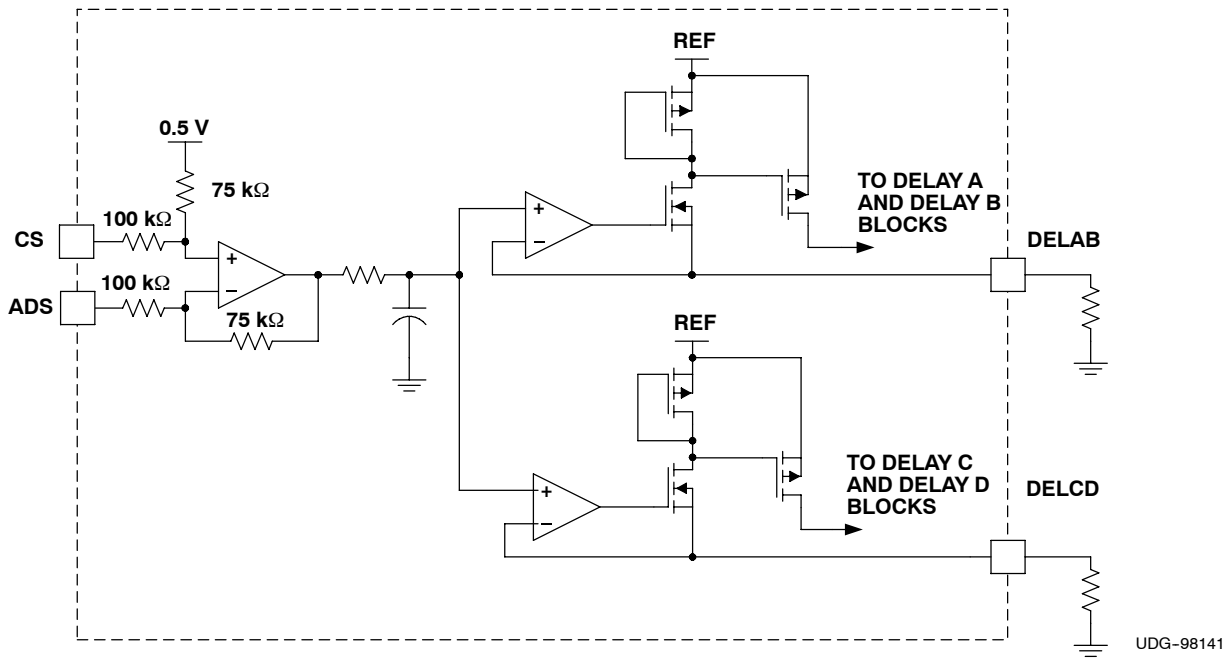

**Figure 2. Adaptive Delay Set Block Diagram**

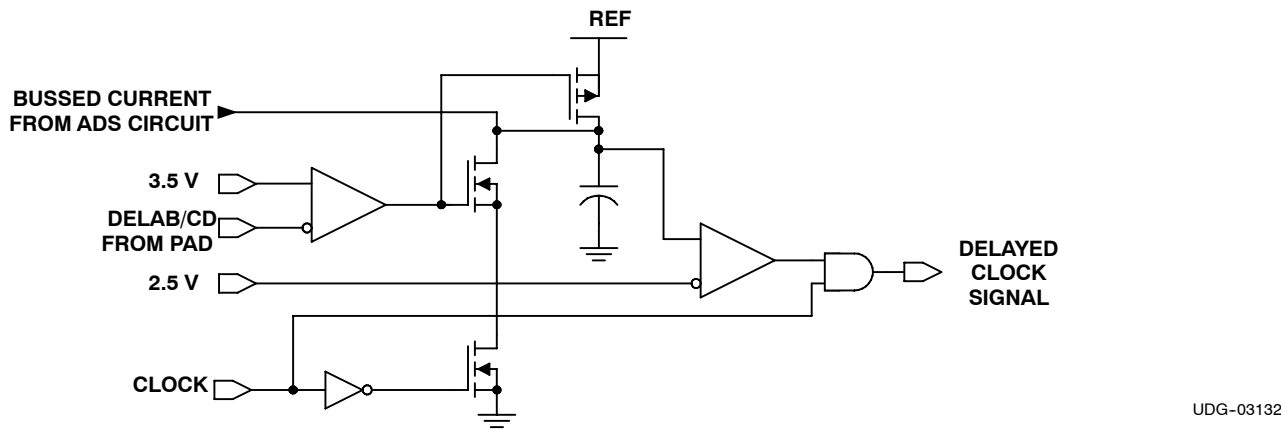

**Figure 3. Delay Block Diagram (One Delay Block Per Outlet)**



## DETAILED PIN DESCRIPTION

### Adaptive Delay Set (ADS)

This function sets the ratio between the maximum and minimum programmed output-delay dead time. When the ADS pin is directly connected to the CS pin, no delay modulation occurs. The maximum delay modulation occurs when ADS is grounded. In this case, delay time is four times longer when CS = 0 than when CS = 2.0 V (the peak-current threshold), ADS changes the output voltage on the delay pins DELAB and DELCD by the following formula:

$$V_{\text{DEL}} = \left[ 0.75 \times (V_{\text{CS}} - V_{\text{ADS}}) \right] + 0.5 \text{ V} \quad (1)$$

where  $V_{\text{CS}}$  and  $V_{\text{ADS}}$  are in volts. ADS must be limited to between 0 V and 2.5 V and must be less than or equal to CS. DELAB and DELCD are clamped to a minimum of 0.5 V.

### Current Sense (CS)

The inverting input of the current-sense comparator and the non-inverting input of the overcurrent comparator and the ADS amplifier. The current sense signal is used for cycle-by-cycle current limiting in peak current mode control, and for overcurrent protection in all cases with a secondary threshold for output shutdown. An output disable initiated by an overcurrent fault also results in a restart cycle, called *soft stop*, with full soft start.

### Oscillator Timing Capacitor (CT)

The UCC3895's oscillator charges CT via a programmed current. The waveform on  $C_T$  is a sawtooth, with a peak voltage of 2.35 V. The approximate oscillator period is calculated by the following formula:

$$t_{\text{OSC}} = \frac{5 \times R_T \times C_T}{48} + 120 \text{ ns} \quad (2)$$

where  $C_T$  is in Farads, and  $R_T$  is in Ohms and  $t_{\text{OSC}}$  is in seconds.  $C_T$  can range from 100 pF to 880 pF.

**NOTE:** A large  $C_T$  and a small  $R_T$  combination results in extended fall times on the  $C_T$  waveform. The increased fall time increases the SYNC pulse width, hence limiting the maximum phase shift between OUTA, OUTB and OUTC, OUTD outputs, which limits the maximum duty cycle of the converter. (Refer to Figure 1)

### Delay Programming Between Complementary Outputs (DELAB, DELCD)

DELAB programs the dead time between switching of OUTA and OUTB, and DELCD programs the dead time between OUTC and OUTD. This delay is introduced between complementary outputs in the same leg of the external bridge. The UCC2895N allows the user to select the delay, in which the resonant switching of the external power stages takes place. Separate delays are provided for the two half-bridges to accommodate differences in resonant-capacitor charging currents. The delay in each stage is set according to the following formula:

$$t_{\text{DELAY}} = \frac{(25 \times 10^{-12}) \times R_{\text{DEL}}}{V_{\text{DEL}}} + 25 \text{ ns} \quad (3)$$

where  $V_{\text{DEL}}$  (V), and  $R_{\text{DEL}}$  is in ( $\Omega$ ) and  $t_{\text{DELAY}}$  is in seconds. DELAB and DELCD can source about 1 mA maximum. Choose the delay resistors so that this maximum is not exceeded. Programmable output delay is defeated by tying DELAB and/or DELCD to REF. For an optimum performance keep stray capacitance on these pins at less than 10 pF.

## DETAILED PIN DESCRIPTION (continued)

### Error Amplifier (EAOUT), (EAP), (EAN)

EAOUT connected internally to the non-inverting input of the PWM comparator and the no-load comparator. EAOUT is internally clamped to the soft-start voltage. The no-load comparator shuts down the output stages when EAOUT falls below 500 mV, and allows the outputs to turn on again when EAOUT rises above 600 mV.

EAP is the non-inverting and the EAN is the inverting input to the error amplifier.

### Output MOSFET Drivers (OUTA, OUTB, OUTC, OUTD)

The 4 outputs are 100-mA complementary MOS drivers, and are optimized to drive MOSFET driver circuits. OUTA and OUTB are fully complementary, (assuming no programming delay). They operate near 50% duty cycle and one-half the oscillator frequency. OUTA and OUTB are intended to drive one half-bridge circuit in an external power stage. OUTC and OUTD drive the other half-bridge and have the same characteristics as OUTA and OUTB. OUTC is phase shifted with respect to OUTA, and OUTD is phase shifted with respect to OUTB.

**NOTE:** Changing the phase relationship of OUTC and OUTD with respect to OUTA and OUTB requires other than the nominal 50% duty ratio on OUTC and OUTD during those transients.

### Power Ground (PGND)

To keep output switching noise from critical analog circuits, the UCC3895 has two different ground connections. PGND is the ground connection for the high-current output stages. Both GND and PGND must be electrically tied together. Also, since PGND carries high current, board traces must be low impedance.

### Inverting Input of the PWM Comparator (RAMP)

This pin receives either the  $C_T$  waveform in voltage and average current-mode controls, or the current signal (plus slope compensation) in peak current-mode control.

### Voltage Reference (REF)

The 5 V,  $\pm 1.2\%$  reference supplies power to internal circuitry, and can also supply up to 5 mA to external loads. The reference is shut down during undervoltage lockout but is operational during all other disable modes. For best performance, bypass with a 0.1- $\mu$ F, low-ESR, low-ESL capacitor to GND. Do not use more than 1.0  $\mu$ F of total capacitance on this pin. To ensure the stability of the internal reference.

### Oscillator Timing Resistor (RT)

The oscillator in the UCC3895 operates by charging an external timing capacitor,  $C_T$ , with a fixed current programmed by  $R_T$ .  $R_T$  current is calculated as follows:

$$I_{RT} \text{ (A)} = \frac{3.0 \text{ V}}{R_T \text{ } (\Omega)} \quad (4)$$

$R_T$  can range from 40 k $\Omega$  to 120 k $\Omega$ . Soft-start charging and discharging currents are also programmed by  $I_{RT}$  (Refer to Figure 1).

### Analog Ground (GND)

This pin is the chip ground for all internal circuits except the output stages.

---

## DETAILED PIN DESCRIPTION (continued)

### Soft-Start/Disable (SS/DISB)

This pin combines two independent functions.

**Disable Mode:** A rapid shutdown of the chip is accomplished by externally forcing SS/DISB below 0.5 V, externally forcing REF below 4 V, or if VDD drops below the undervoltage lockout threshold. In the case of REF being pulled below 4 V or an undervoltage condition, SS/DISB is actively pulled to ground via an internal MOSFET switch.

If an overcurrent fault is sensed ( $CS = 2.5\text{ V}$ ), a *soft-stop* is initiated. In this mode, SS/DISB sinks a constant current of  $(10 \times I_{RT})$ . The soft-stop continues until SS/DISB falls below 0.5 V. When any of these faults are detected, all outputs are forced to ground immediately.

**NOTE:** If SS/DISB is forced below 0.5 V, the pin starts to source current equal to  $I_{RT}$ . The only time the part switches into low  $I_{DD}$  current mode, though, is when the part is in undervoltage lockout.

**Soft-start Mode:** After a fault or disable condition has passed, VDD is above the start threshold, and/or SS/DISB falls below 0.5 V during a soft-stop, SS/DISB switches to a soft-start mode. The pin then sources current, equal to  $I_{RT}$ . A user-selected resistor/capacitor combination on SS/DISB determines the soft start time constant.

**NOTE:** SS/DISB actively clamps the EAOUT pin voltage to approximately the SS/DISB pin voltage during both soft-start, soft-stop, and disable conditions.

### Oscillator Synchronization (SYNC)

This pin is bidirectional (refer to Figure 1). When used as an output, SYNC can be used as a clock, which is the same as the device's internal clock. When used as an input, SYNC overrides the chip's internal oscillator and act as its clock signal. This bidirectional feature allows synchronization of multiple power supplies. Also, the SYNC signal internally discharge the  $C_T$  capacitor and any filter capacitors that are present on the RAMP pin. The internal SYNC circuitry is level sensitive, with an input-low threshold of 1.9 V, and an input-high threshold of 2.1 V. A resistor as small as 3.9 k $\Omega$  may be tied between SYNC and GND to reduce the sync pulse width.

### Chip Supply (VDD)

This is the input pin to the chip. VDD must be bypassed with a minimum of 1.0  $\mu\text{F}$  low ESR, low ESL capacitor to ground. The addition of a 10- $\mu\text{F}$  low ESR, low ESL between VDD and PGND is recommended.

**APPLICATION INFORMATION**

**Programming DELAB, DELCD and the Adaptive Delay Set**

The UCC2895N allows the user to set the delay between switch commands within each leg of the full-bridge power circuit according to equations:

$$t_{\text{DELAY}} = \frac{(25 \times 10^{-12}) \times R_{\text{DEL}}}{V_{\text{DEL}}} + 25 \text{ ns} \tag{5}$$

From this equation V<sub>DEL</sub> is determined in conjunction with the desire to use (or not) the adaptive delay set feature from the following formula:

$$V_{\text{DEL}} = [0.75 \times (V_{\text{CS}} - V_{\text{ADS}})] + 0.5 \text{ V} \tag{6}$$

The following diagram illustrates the resistors needed to program the delay periods and the adaptive delay set function.

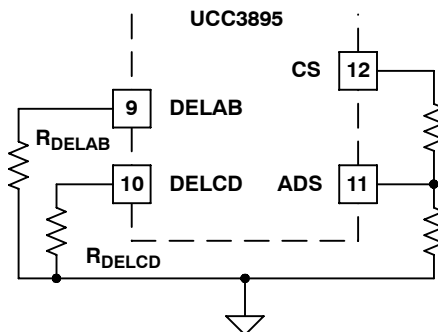

**Figure 4. Programming Adaptive Delay Set**

The adaptive delay set feature (ADS) allows the user to vary the delay times between switch commands within each of the converter’s two legs. The delay-time modulation is implemented by connecting ADS (pin 11) to CS, GND, or a resistive divider from CS through ADS to GND to set V<sub>ADS</sub> as shown in Figure 4. From equation (6) for V<sub>DEL</sub>, if ADS is tied to GND then V<sub>DEL</sub> rises in direct proportion to V<sub>CS</sub>, causing a decrease in t<sub>DELAY</sub> as the load increases. In this condition, the maximum value of V<sub>DEL</sub> is 2 V.

If ADS is connected to a resistive divider between CS and GND, the term (V<sub>CS</sub>-V<sub>ADS</sub>) becomes smaller, reducing the level of V<sub>DEL</sub>. This decreases the amount of delay modulation. In the limit of ADS tied to CS, V<sub>DEL</sub> = 0.5 V and no delay modulation occurs. Figure 5 graphically shows the delay time vs. load for varying adaptive delay set feature voltages (V<sub>ADS</sub>).

In the case of maximum delay modulation (ADS=GND), when the circuit goes from light load to heavy load, the variation of V<sub>DEL</sub> is from 0.5 V to 2 V. This causes the delay times to vary by a 4:1 ratio as the load is changed.

The ability to program an adaptive delay is a desirable feature because the optimum delay time is a function of the current flowing in the primary winding of the transformer, and can change by a factor of 10:1 or more as circuit loading changes. Reference<sup>[5]</sup> describes the many interrelated factors for choosing the optimum delay times for the most efficient power conversion, and illustrates an external circuit to enable adaptive delay set using the UC3879. Implementing this adaptive feature is simplified in the UCC3895 controller, giving the user the ability to tailor the delay times to suit a particular application with a minimum of external parts.

APPLICATION INFORMATION

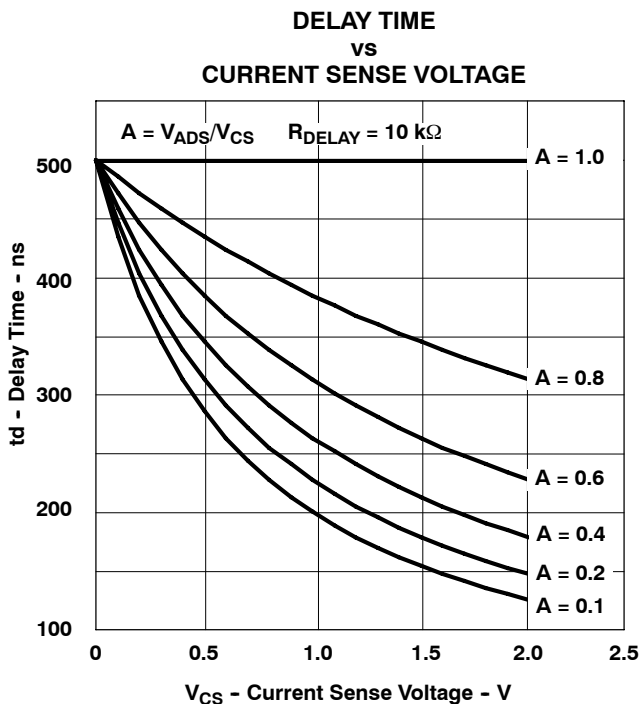

Figure 5. Delay Time Under Varying ADS Voltages

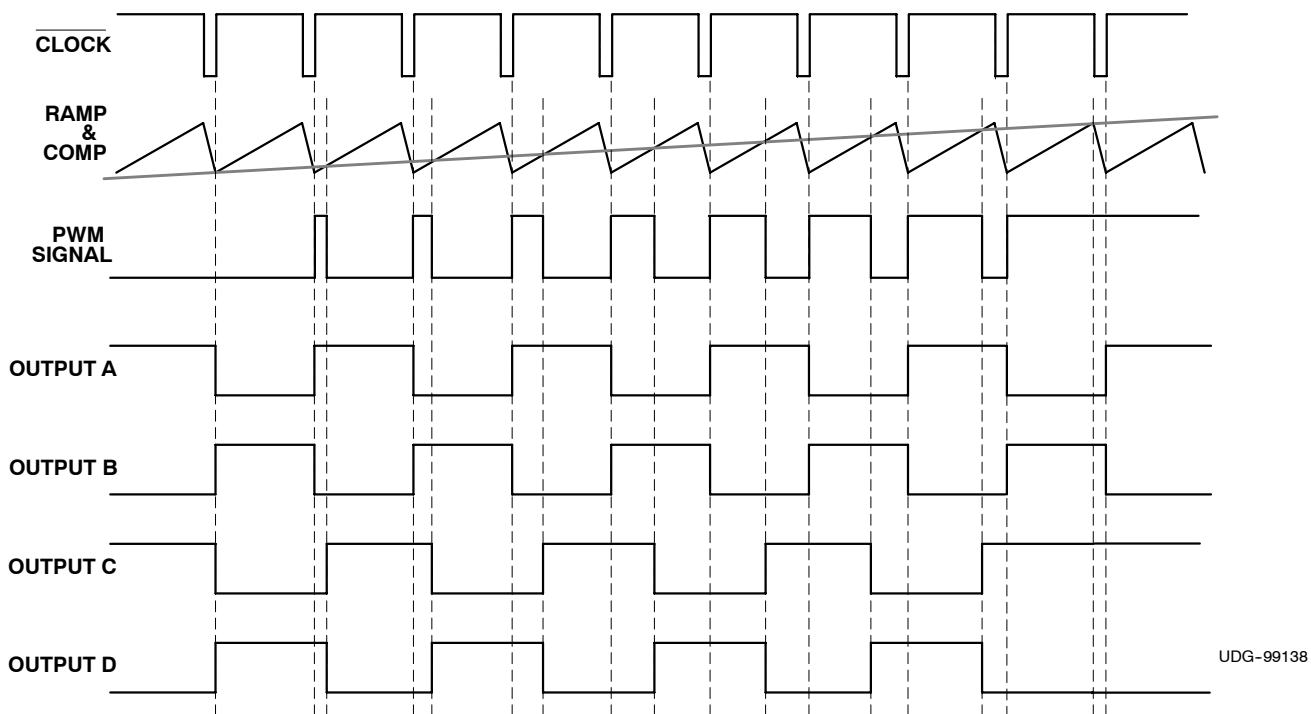

Figure 6. UCC3895 Timing Diagram (No Output Delay Shown, COMP to RAMP offset not included)

TYPICAL CHARACTERISTICS

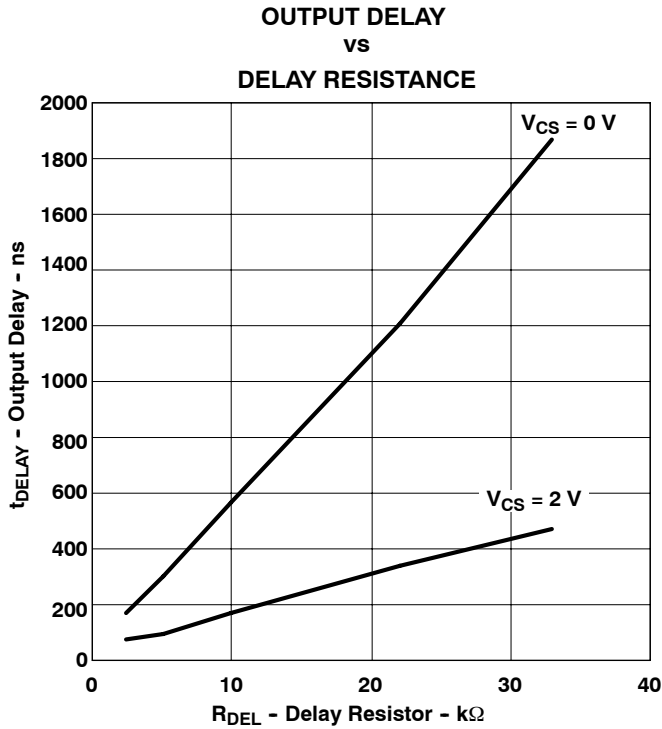

Figure 7

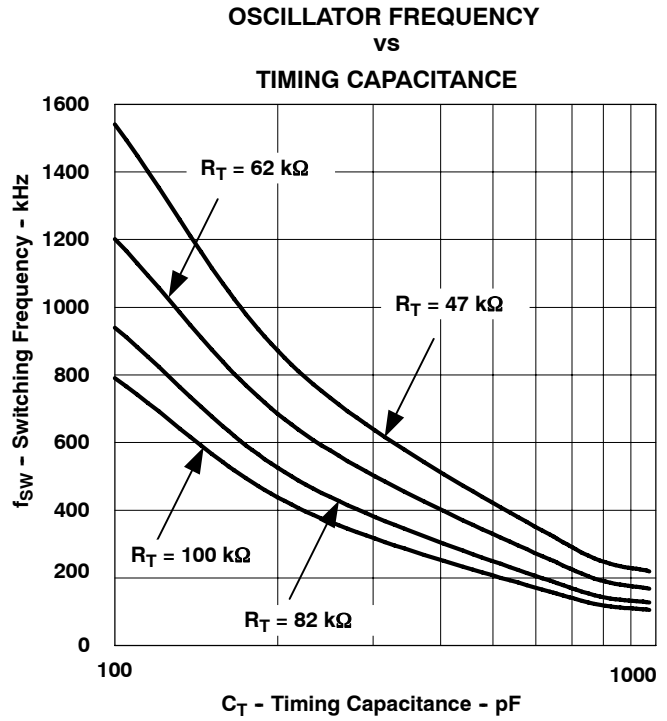

Figure 8

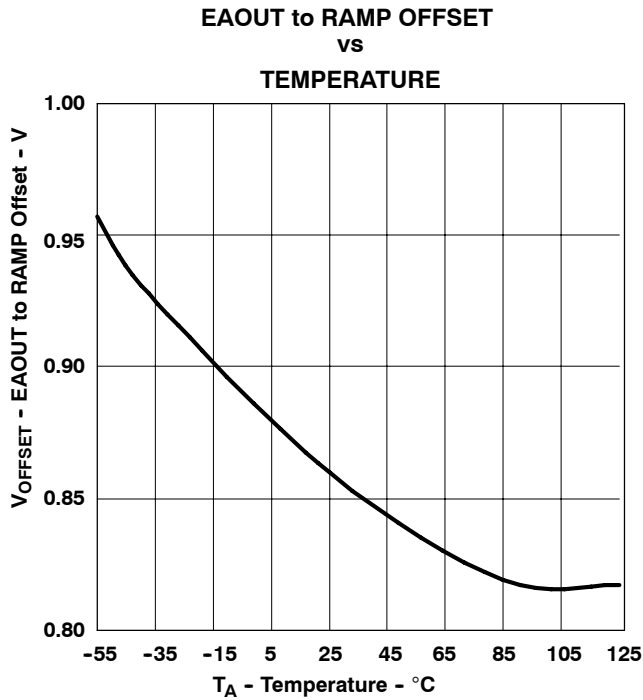

Figure 9

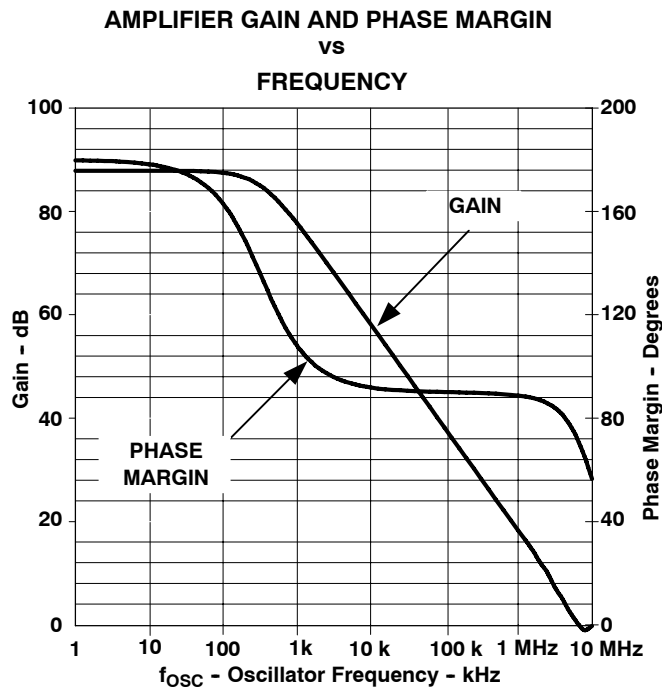

Figure 10

TYPICAL CHARACTERISTICS

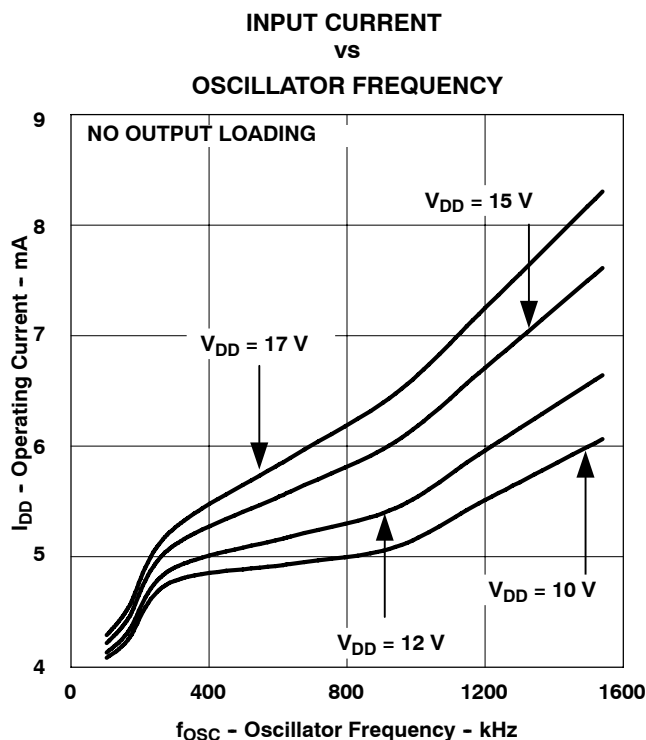

Figure 11

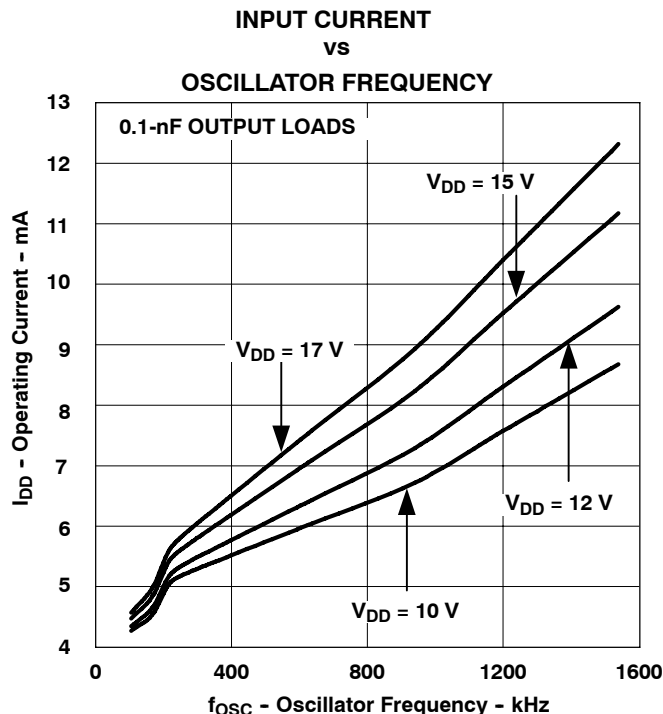

Figure 12

REFERENCES

1. M. Dennis, *A Comparison Between the BiCMOS UCC3895 Phase Shift Controller and the UC3875* Application Note (SLUA246).
2. L. Balogh, *The Current-Doubler Rectifier: An Alternative Rectification Technique for Push-Pull and Bridge Converters* Application Note (SLUA121).
3. W. Andreyca, *Phase Shifted, Zero Voltage Transition Design Considerations*, Application Note (SLUA107).
4. L. Balogh, *The New UC3879 Phase Shifted PWM Controller Simplifies the Design of Zero Voltage Transition Full-Bridge Converters*, Application Note (SLUA122).
5. L. Balogh, *Design Review: 100 W, 400 kHz, dc-to-dc Converter with Current Doubler Synchronous Rectification Achieves 92% Efficiency*, Unitrode Power Supply Design Seminar Manual, SEM-1100, 1996, Topic 2.
6. UC3875 Phase Shift Resonant Controller, Datasheet, (SLUS229).
7. UC3879 Phase Shift Resonant Controller, Datasheet, (SLUS230).
8. UCC3895EVM-1, "Configuring the UCC3895 for direct Control Driven Synchronous Rectification, (Texas Instrument's Literature Number SLUU109A)
9. UCC3895, CD Output Asymmetrical Duty Cycle Operation, (Texas Instrument's Literature Number SLUA275)
10. Texas Instrument's Literature Number SLUA323
11. Synchronous Rectifiers of a Current Doubler, (Texas Instrument's Literature Number SLUA287)

**REVISION HISTORY**

1. Page 6, changed REF pin description from "Do not use more than 1.0  $\mu$ F of total capacitance on this pin." to "Do not use more than 4.7  $\mu$ F of total capacitance on this pin."
2. Page 2, added thermal information table.



**PACKAGING INFORMATION**

Orderable Device	Status <sup>(1)</sup>	Package Type	Package Drawing	Pins	Package Qty	Eco Plan <sup>(2)</sup>	Lead/Ball Finish	MSL Peak Temp <sup>(3)</sup>
UCC1895J	ACTIVE	CDIP	J	20	1	TBD	A42	N / A for Pkg Type
UCC1895L	ACTIVE	LCCC	FK	20	1	TBD	POST-PLATE	N / A for Pkg Type
UCC2895DW	ACTIVE	SOIC	DW	20	25	Green (RoHS & no Sb/Br)	CU NIPDAU	Level-2-260C-1 YEAR
UCC2895DWG4	ACTIVE	SOIC	DW	20	25	Green (RoHS & no Sb/Br)	CU NIPDAU	Level-2-260C-1 YEAR
UCC2895DWTR	ACTIVE	SOIC	DW	20	2000	Green (RoHS & no Sb/Br)	CU NIPDAU	Level-2-260C-1 YEAR
UCC2895DWTRG4	ACTIVE	SOIC	DW	20	2000	Green (RoHS & no Sb/Br)	CU NIPDAU	Level-2-260C-1 YEAR
UCC2895N	ACTIVE	PDIP	N	20	20	Green (RoHS & no Sb/Br)	CU NIPDAU	N / A for Pkg Type
UCC2895NG4	ACTIVE	PDIP	N	20	20	Green (RoHS & no Sb/Br)	CU NIPDAU	N / A for Pkg Type
UCC2895PW	ACTIVE	TSSOP	PW	20	70	Green (RoHS & no Sb/Br)	CU NIPDAU	Level-2-260C-1 YEAR
UCC2895PWG4	ACTIVE	TSSOP	PW	20	70	Green (RoHS & no Sb/Br)	CU NIPDAU	Level-2-260C-1 YEAR
UCC2895PWTR	ACTIVE	TSSOP	PW	20	2000	Green (RoHS & no Sb/Br)	CU NIPDAU	Level-2-260C-1 YEAR
UCC2895PWTRG4	ACTIVE	TSSOP	PW	20	2000	Green (RoHS & no Sb/Br)	CU NIPDAU	Level-2-260C-1 YEAR
UCC2895Q	ACTIVE	PLCC	FN	20	46	Green (RoHS & no Sb/Br)	CU SN	Level-2-260C-1 YEAR
UCC2895QG3	ACTIVE	PLCC	FN	20	46	Green (RoHS & no Sb/Br)	CU SN	Level-2-260C-1 YEAR
UCC3895DW	ACTIVE	SOIC	DW	20	25	Green (RoHS & no Sb/Br)	CU NIPDAU	Level-2-260C-1 YEAR
UCC3895DWG4	ACTIVE	SOIC	DW	20	25	Green (RoHS & no Sb/Br)	CU NIPDAU	Level-2-260C-1 YEAR
UCC3895DWTR	ACTIVE	SOIC	DW	20	2000	Green (RoHS & no Sb/Br)	CU NIPDAU	Level-2-260C-1 YEAR
UCC3895DWTRG4	ACTIVE	SOIC	DW	20	2000	Green (RoHS & no Sb/Br)	CU NIPDAU	Level-2-260C-1 YEAR
UCC3895N	ACTIVE	PDIP	N	20	20	Green (RoHS & no Sb/Br)	CU NIPDAU	N / A for Pkg Type
UCC3895NG4	ACTIVE	PDIP	N	20	20	Green (RoHS & no Sb/Br)	CU NIPDAU	N / A for Pkg Type
UCC3895PW	ACTIVE	TSSOP	PW	20	70	Green (RoHS & no Sb/Br)	CU NIPDAU	Level-2-260C-1 YEAR
UCC3895PWG4	ACTIVE	TSSOP	PW	20	70	Green (RoHS & no Sb/Br)	CU NIPDAU	Level-2-260C-1 YEAR
UCC3895PWTR	ACTIVE	TSSOP	PW	20	2000	Green (RoHS & no Sb/Br)	CU NIPDAU	Level-2-260C-1 YEAR
UCC3895PWTRG4	ACTIVE	TSSOP	PW	20	2000	Green (RoHS & no Sb/Br)	CU NIPDAU	Level-2-260C-1 YEAR
UCC3895Q	ACTIVE	PLCC	FN	20	46	Green (RoHS & no Sb/Br)	CU SN	Level-2-260C-1 YEAR
UCC3895QG3	ACTIVE	PLCC	FN	20	46	Green (RoHS & no Sb/Br)	CU SN	Level-2-260C-1 YEAR

Orderable Device	Status <sup>(1)</sup>	Package Type	Package Drawing	Pins	Package Qty	Eco Plan <sup>(2)</sup>	Lead/Ball Finish	MSL Peak Temp <sup>(3)</sup>
no Sb/Br)								

<sup>(1)</sup> The marketing status values are defined as follows:

**ACTIVE:** Product device recommended for new designs.

**LIFEBUY:** TI has announced that the device will be discontinued, and a lifetime-buy period is in effect.

**NRND:** Not recommended for new designs. Device is in production to support existing customers, but TI does not recommend using this part in a new design.

**PREVIEW:** Device has been announced but is not in production. Samples may or may not be available.

**OBSOLETE:** TI has discontinued the production of the device.

<sup>(2)</sup> Eco Plan - The planned eco-friendly classification: Pb-Free (RoHS), Pb-Free (RoHS Exempt), or Green (RoHS & no Sb/Br) - please check <http://www.ti.com/productcontent> for the latest availability information and additional product content details.

**TBD:** The Pb-Free/Green conversion plan has not been defined.

**Pb-Free (RoHS):** TI's terms "Lead-Free" or "Pb-Free" mean semiconductor products that are compatible with the current RoHS requirements for all 6 substances, including the requirement that lead not exceed 0.1% by weight in homogeneous materials. Where designed to be soldered at high temperatures, TI Pb-Free products are suitable for use in specified lead-free processes.

**Pb-Free (RoHS Exempt):** This component has a RoHS exemption for either 1) lead-based flip-chip solder bumps used between the die and package, or 2) lead-based die adhesive used between the die and leadframe. The component is otherwise considered Pb-Free (RoHS compatible) as defined above.

**Green (RoHS & no Sb/Br):** TI defines "Green" to mean Pb-Free (RoHS compatible), and free of Bromine (Br) and Antimony (Sb) based flame retardants (Br or Sb do not exceed 0.1% by weight in homogeneous material)

<sup>(3)</sup> MSL, Peak Temp. -- The Moisture Sensitivity Level rating according to the JEDEC industry standard classifications, and peak solder temperature.

**Important Information and Disclaimer:**The information provided on this page represents TI's knowledge and belief as of the date that it is provided. TI bases its knowledge and belief on information provided by third parties, and makes no representation or warranty as to the accuracy of such information. Efforts are underway to better integrate information from third parties. TI has taken and continues to take reasonable steps to provide representative and accurate information but may not have conducted destructive testing or chemical analysis on incoming materials and chemicals. TI and TI suppliers consider certain information to be proprietary, and thus CAS numbers and other limited information may not be available for release.

In no event shall TI's liability arising out of such information exceed the total purchase price of the TI part(s) at issue in this document sold by TI to Customer on an annual basis.

**OTHER QUALIFIED VERSIONS OF UCC1895, UCC2895, UCC3895 :**

- Automotive: [UCC2895-Q1](#)
- Enhanced Product: [UCC2895-EP](#)

NOTE: Qualified Version Definitions:

- Automotive - Q100 devices qualified for high-reliability automotive applications targeting zero defects
- Enhanced Product - Supports Defense, Aerospace and Medical Applications

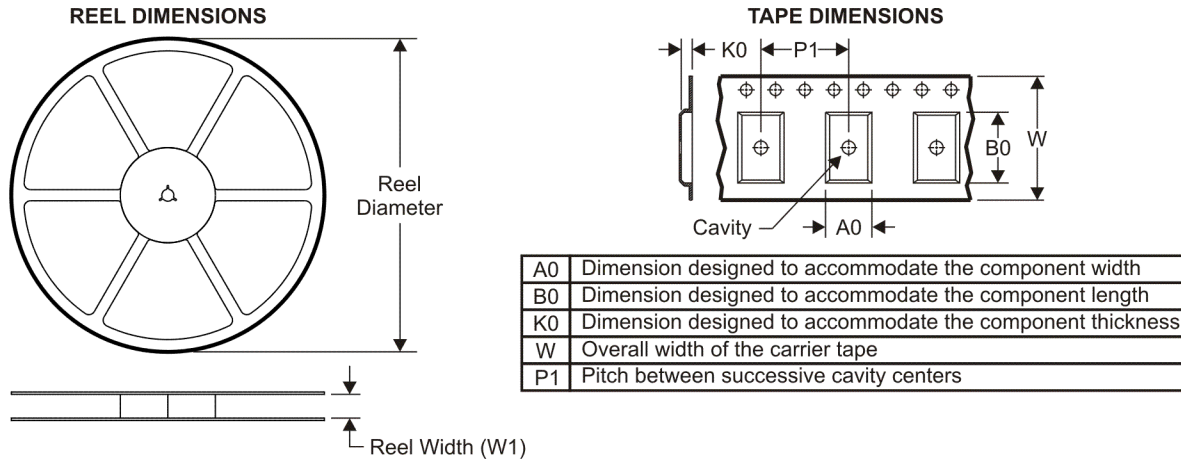
**TAPE AND REEL INFORMATION**

**QUADRANT ASSIGNMENTS FOR PIN 1 ORIENTATION IN TAPE**

\*All dimensions are nominal

Device	Package Type	Package Drawing	Pins	SPQ	Reel Diameter (mm)	Reel Width W1 (mm)	A0 (mm)	B0 (mm)	K0 (mm)	P1 (mm)	W (mm)	Pin1 Quadrant
UCC2895DWTR	SOIC	DW	20	2000	330.0	24.4	10.8	13.0	2.7	12.0	24.0	Q1
UCC2895PWTR	TSSOP	PW	20	2000	330.0	16.4	6.95	7.1	1.6	8.0	16.0	Q1
UCC3895DWTR	SOIC	DW	20	2000	330.0	24.4	10.8	13.0	2.7	12.0	24.0	Q1
UCC3895PWTR	TSSOP	PW	20	2000	330.0	16.4	6.95	7.1	1.6	8.0	16.0	Q1

**TAPE AND REEL BOX DIMENSIONS**

\*All dimensions are nominal

Device	Package Type	Package Drawing	Pins	SPQ	Length (mm)	Width (mm)	Height (mm)
UCC2895DWTR	SOIC	DW	20	2000	346.0	346.0	41.0
UCC2895PWTR	TSSOP	PW	20	2000	346.0	346.0	33.0
UCC3895DWTR	SOIC	DW	20	2000	346.0	346.0	41.0
UCC3895PWTR	TSSOP	PW	20	2000	346.0	346.0	33.0

J (R-GDIP-T\*\*)  
14 LEADS SHOWN

CERAMIC DUAL IN-LINE PACKAGE

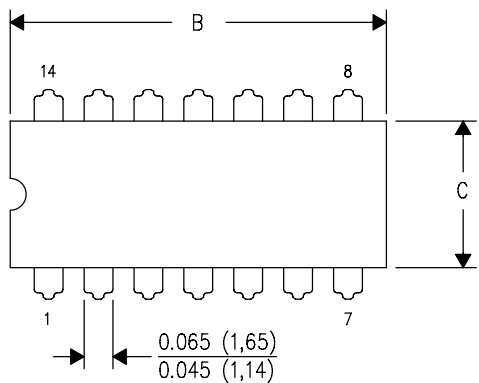

DIM \ PINS **	14	16	18	20
A	0.300 (7,62) BSC	0.300 (7,62) BSC	0.300 (7,62) BSC	0.300 (7,62) BSC
B MAX	0.785 (19,94)	.840 (21,34)	0.960 (24,38)	1.060 (26,92)
B MIN	—	—	—	—
C MAX	0.300 (7,62)	0.300 (7,62)	0.310 (7,87)	0.300 (7,62)
C MIN	0.245 (6,22)	0.245 (6,22)	0.220 (5,59)	0.245 (6,22)

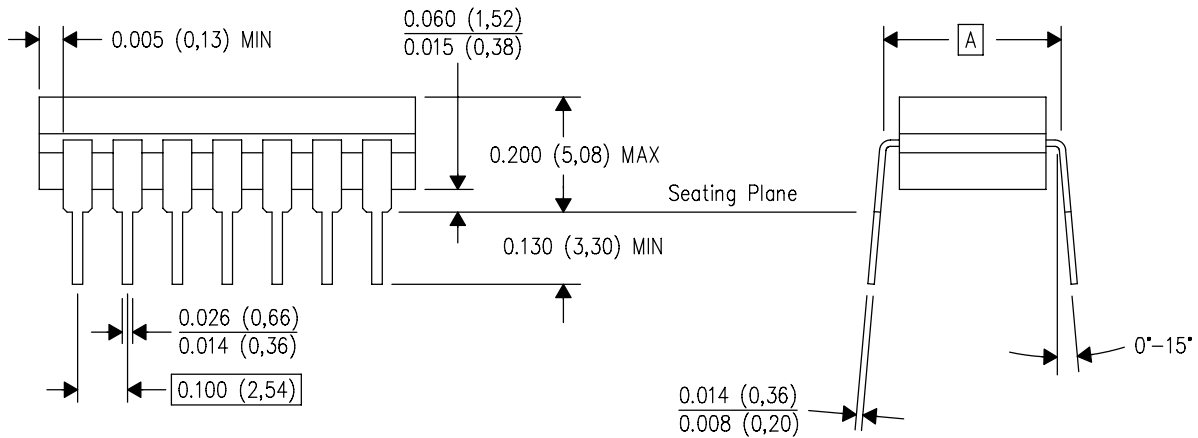

4040083/F 03/03

- NOTES:
- All linear dimensions are in inches (millimeters).
  - This drawing is subject to change without notice.
  - This package is hermetically sealed with a ceramic lid using glass frit.
  - Index point is provided on cap for terminal identification only on press ceramic glass frit seal only.
  - Falls within MIL STD 1835 GDIP1-T14, GDIP1-T16, GDIP1-T18 and GDIP1-T20.

FK (S-CQCC-N\*\*)

LEADLESS CERAMIC CHIP CARRIER

28 TERMINAL SHOWN

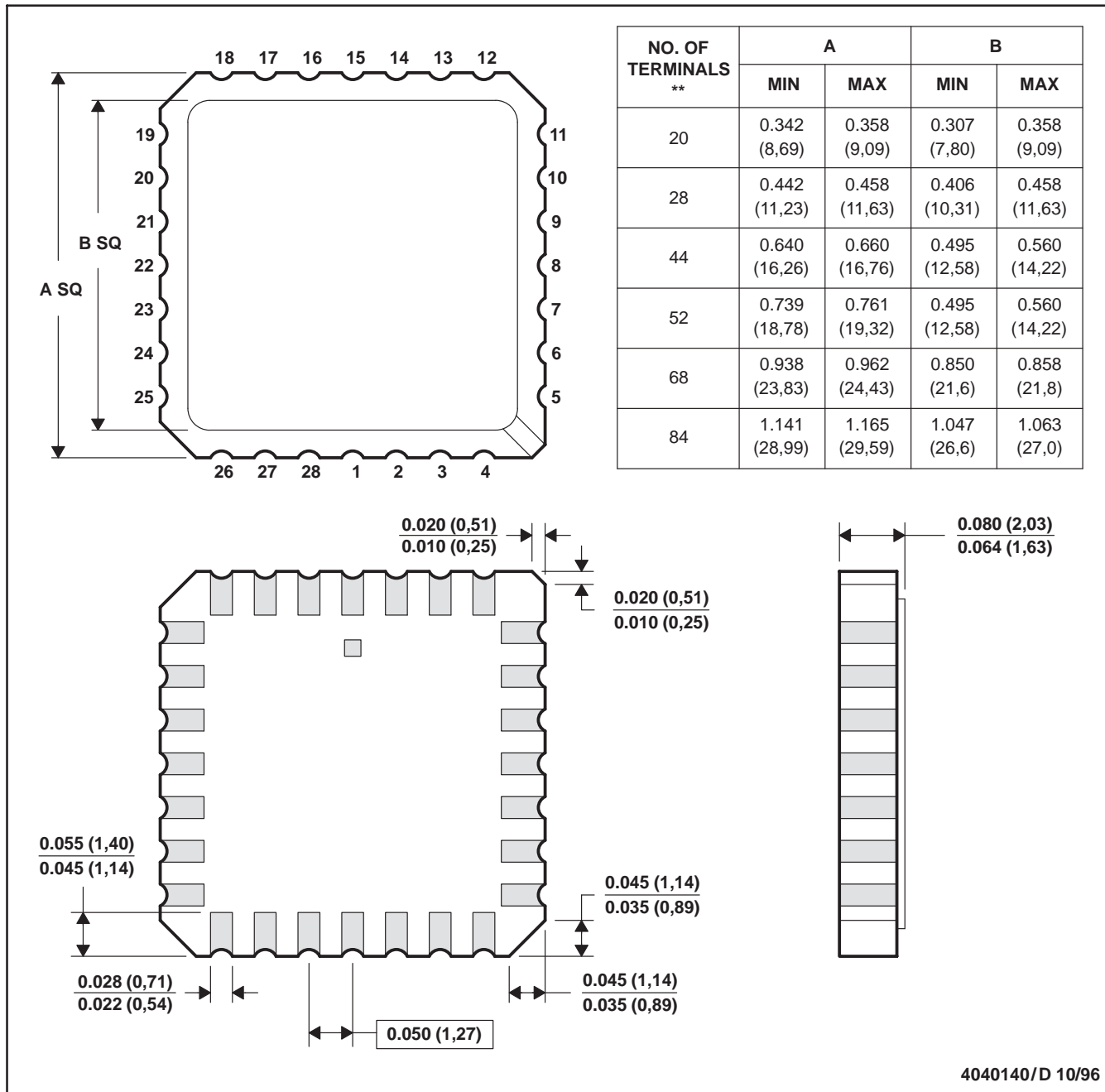

- NOTES:
- A. All linear dimensions are in inches (millimeters).
  - B. This drawing is subject to change without notice.
  - C. This package can be hermetically sealed with a metal lid.
  - D. The terminals are gold plated.
  - E. Falls within JEDEC MS-004

DW (R-PDSO-G20)

PLASTIC SMALL-OUTLINE PACKAGE

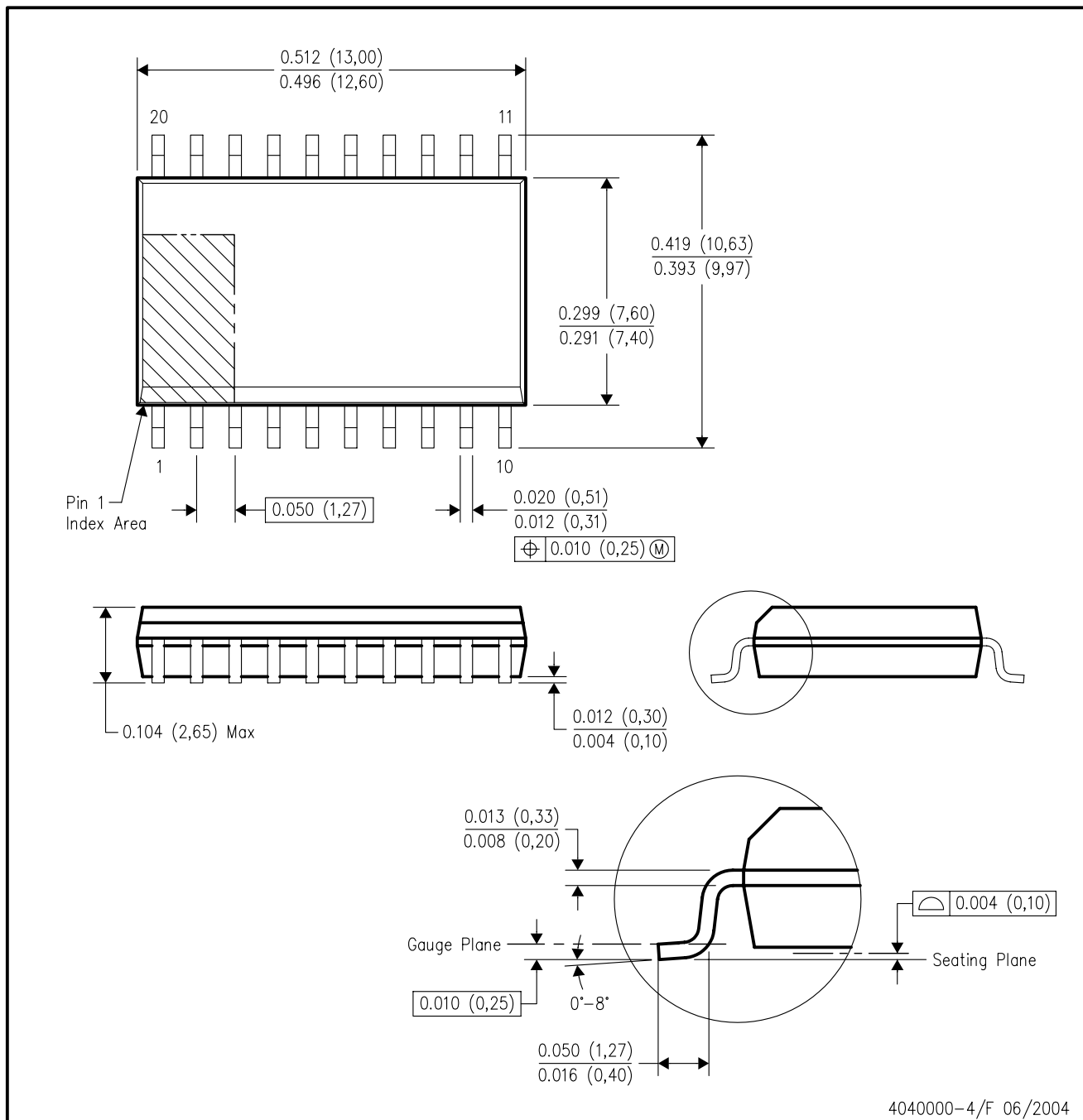

- NOTES:
- A. All linear dimensions are in inches (millimeters).
  - B. This drawing is subject to change without notice.
  - C. Body dimensions do not include mold flash or protrusion not to exceed 0.006 (0,15).
  - D. Falls within JEDEC MS-013 variation AC.

FN (S-PQCC-J\*\*)

PLASTIC J-LEADED CHIP CARRIER

20 PIN SHOWN

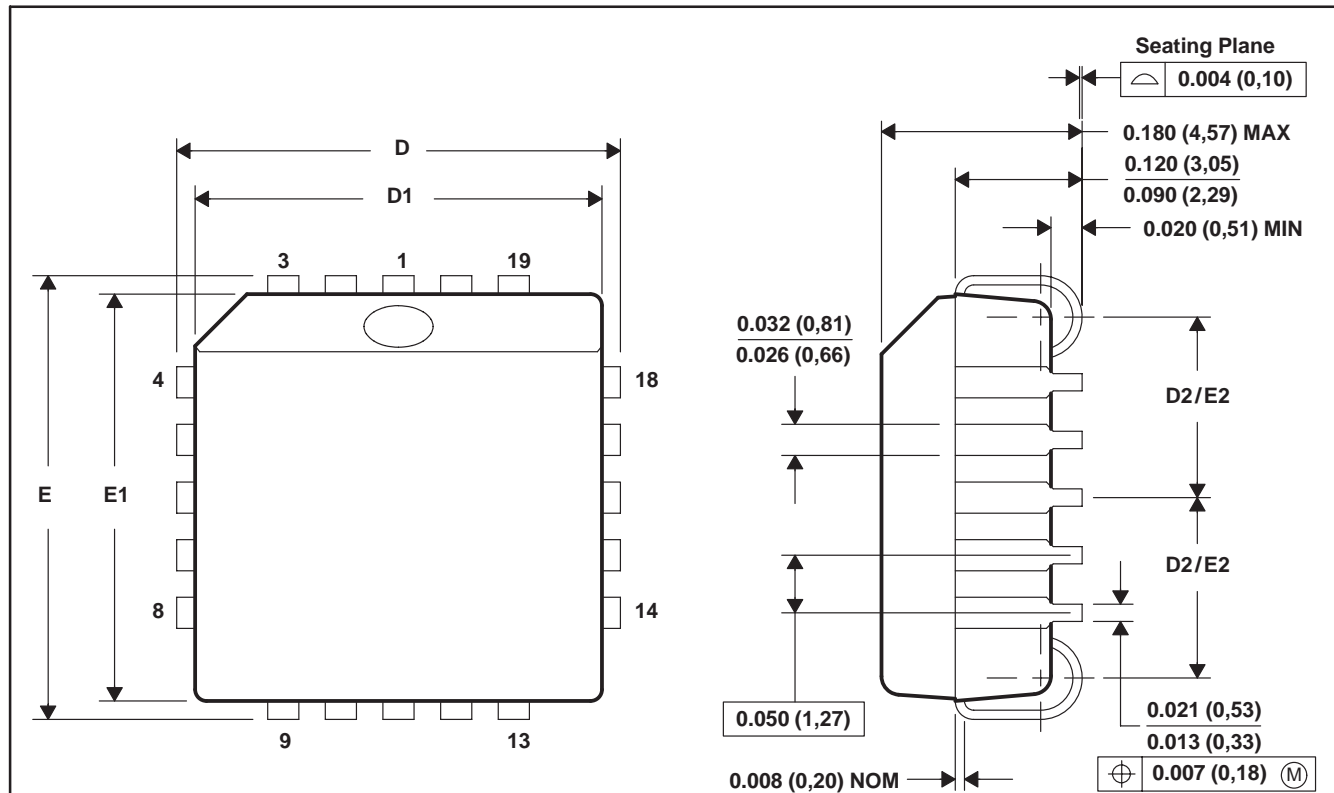

NO. OF PINS **	D/E		D1/E1		D2/E2	
	MIN	MAX	MIN	MAX	MIN	MAX
20	0.385 (9,78)	0.395 (10,03)	0.350 (8,89)	0.356 (9,04)	0.141 (3,58)	0.169 (4,29)
28	0.485 (12,32)	0.495 (12,57)	0.450 (11,43)	0.456 (11,58)	0.191 (4,85)	0.219 (5,56)
44	0.685 (17,40)	0.695 (17,65)	0.650 (16,51)	0.656 (16,66)	0.291 (7,39)	0.319 (8,10)
52	0.785 (19,94)	0.795 (20,19)	0.750 (19,05)	0.756 (19,20)	0.341 (8,66)	0.369 (9,37)
68	0.985 (25,02)	0.995 (25,27)	0.950 (24,13)	0.958 (24,33)	0.441 (11,20)	0.469 (11,91)
84	1.185 (30,10)	1.195 (30,35)	1.150 (29,21)	1.158 (29,41)	0.541 (13,74)	0.569 (14,45)

4040005/B 03/95

- NOTES: A. All linear dimensions are in inches (millimeters).  
 B. This drawing is subject to change without notice.  
 C. Falls within JEDEC MS-018



PW (R-PDSO-G\*\*)

PLASTIC SMALL-OUTLINE PACKAGE

14 PINS SHOWN

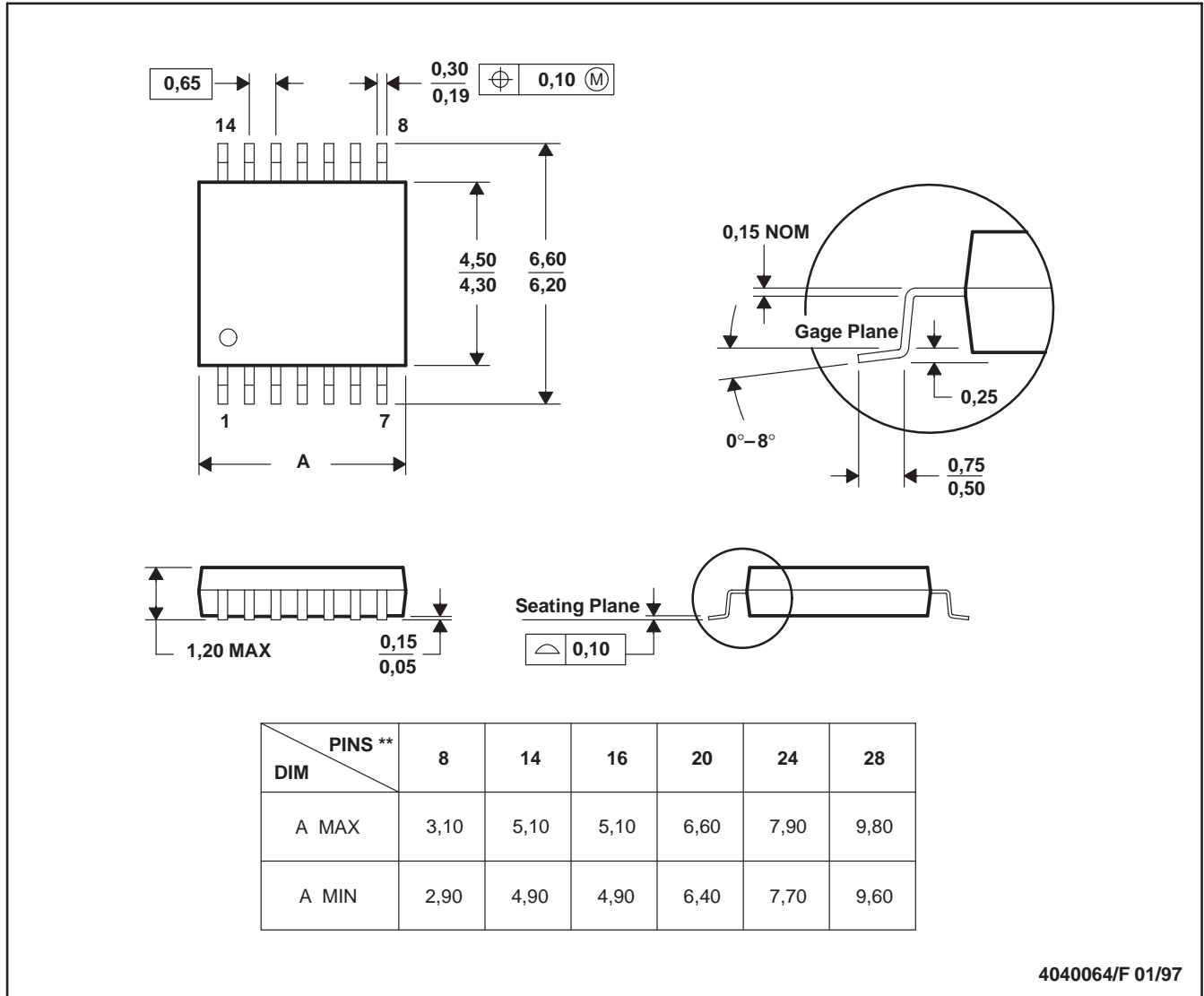

- NOTES: A. All linear dimensions are in millimeters.  
 B. This drawing is subject to change without notice.  
 C. Body dimensions do not include mold flash or protrusion not to exceed 0,15.  
 D. Falls within JEDEC MO-153

## IMPORTANT NOTICE

Texas Instruments Incorporated and its subsidiaries (TI) reserve the right to make corrections, modifications, enhancements, improvements, and other changes to its products and services at any time and to discontinue any product or service without notice. Customers should obtain the latest relevant information before placing orders and should verify that such information is current and complete. All products are sold subject to TI's terms and conditions of sale supplied at the time of order acknowledgment.

TI warrants performance of its hardware products to the specifications applicable at the time of sale in accordance with TI's standard warranty. Testing and other quality control techniques are used to the extent TI deems necessary to support this warranty. Except where mandated by government requirements, testing of all parameters of each product is not necessarily performed.

TI assumes no liability for applications assistance or customer product design. Customers are responsible for their products and applications using TI components. To minimize the risks associated with customer products and applications, customers should provide adequate design and operating safeguards.

TI does not warrant or represent that any license, either express or implied, is granted under any TI patent right, copyright, mask work right, or other TI intellectual property right relating to any combination, machine, or process in which TI products or services are used. Information published by TI regarding third-party products or services does not constitute a license from TI to use such products or services or a warranty or endorsement thereof. Use of such information may require a license from a third party under the patents or other intellectual property of the third party, or a license from TI under the patents or other intellectual property of TI.

Reproduction of TI information in TI data books or data sheets is permissible only if reproduction is without alteration and is accompanied by all associated warranties, conditions, limitations, and notices. Reproduction of this information with alteration is an unfair and deceptive business practice. TI is not responsible or liable for such altered documentation. Information of third parties may be subject to additional restrictions.

Resale of TI products or services with statements different from or beyond the parameters stated by TI for that product or service voids all express and any implied warranties for the associated TI product or service and is an unfair and deceptive business practice. TI is not responsible or liable for any such statements.

TI products are not authorized for use in safety-critical applications (such as life support) where a failure of the TI product would reasonably be expected to cause severe personal injury or death, unless officers of the parties have executed an agreement specifically governing such use. Buyers represent that they have all necessary expertise in the safety and regulatory ramifications of their applications, and acknowledge and agree that they are solely responsible for all legal, regulatory and safety-related requirements concerning their products and any use of TI products in such safety-critical applications, notwithstanding any applications-related information or support that may be provided by TI. Further, Buyers must fully indemnify TI and its representatives against any damages arising out of the use of TI products in such safety-critical applications.

TI products are neither designed nor intended for use in military/aerospace applications or environments unless the TI products are specifically designated by TI as military-grade or "enhanced plastic." Only products designated by TI as military-grade meet military specifications. Buyers acknowledge and agree that any such use of TI products which TI has not designated as military-grade is solely at the Buyer's risk, and that they are solely responsible for compliance with all legal and regulatory requirements in connection with such use.

TI products are neither designed nor intended for use in automotive applications or environments unless the specific TI products are designated by TI as compliant with ISO/TS 16949 requirements. Buyers acknowledge and agree that, if they use any non-designated products in automotive applications, TI will not be responsible for any failure to meet such requirements.

Following are URLs where you can obtain information on other Texas Instruments products and application solutions:

<b>Products</b>		<b>Applications</b>	
Amplifiers	<a href="http://amplifier.ti.com">amplifier.ti.com</a>	Audio	<a href="http://www.ti.com/audio">www.ti.com/audio</a>
Data Converters	<a href="http://dataconverter.ti.com">dataconverter.ti.com</a>	Automotive	<a href="http://www.ti.com/automotive">www.ti.com/automotive</a>
DLP® Products	<a href="http://www.dlp.com">www.dlp.com</a>	Communications and Telecom	<a href="http://www.ti.com/communications">www.ti.com/communications</a>
DSP	<a href="http://dsp.ti.com">dsp.ti.com</a>	Computers and Peripherals	<a href="http://www.ti.com/computers">www.ti.com/computers</a>
Clocks and Timers	<a href="http://www.ti.com/clocks">www.ti.com/clocks</a>	Consumer Electronics	<a href="http://www.ti.com/consumer-apps">www.ti.com/consumer-apps</a>
Interface	<a href="http://interface.ti.com">interface.ti.com</a>	Energy	<a href="http://www.ti.com/energy">www.ti.com/energy</a>
Logic	<a href="http://logic.ti.com">logic.ti.com</a>	Industrial	<a href="http://www.ti.com/industrial">www.ti.com/industrial</a>
Power Mgmt	<a href="http://power.ti.com">power.ti.com</a>	Medical	<a href="http://www.ti.com/medical">www.ti.com/medical</a>
Microcontrollers	<a href="http://microcontroller.ti.com">microcontroller.ti.com</a>	Security	<a href="http://www.ti.com/security">www.ti.com/security</a>
RFID	<a href="http://www.ti-rfid.com">www.ti-rfid.com</a>	Space, Avionics & Defense	<a href="http://www.ti.com/space-avionics-defense">www.ti.com/space-avionics-defense</a>
RF/IF and ZigBee® Solutions	<a href="http://www.ti.com/lprf">www.ti.com/lprf</a>	Video and Imaging	<a href="http://www.ti.com/video">www.ti.com/video</a>
		Wireless	<a href="http://www.ti.com/wireless-apps">www.ti.com/wireless-apps</a>

Mailing Address: Texas Instruments, Post Office Box 655303, Dallas, Texas 75265  
Copyright © 2010, Texas Instruments Incorporated

[www.BDTIC.com/TI](http://www.BDTIC.com/TI)