

Advanced PWM Controller With Pre-Bias Operation

Check for Samples: [UCC28250](#)

FEATURES

- Pre-biased Startup
- Synchronous Rectifier Control Outputs with Programmable Delays (Including Zero Delay Support)
- Voltage Mode Control with Input Voltage Feed-Forward or Current Mode Control
- Primary or Secondary-Side Control
- 3.3-V, 1.5% Accurate Reference Output
- 1-MHz Capable Switching Frequency
- 1% Accurate Cycle-by-Cycle Over Current Protection with Matched Duty Cycle Outputs
- Programmable Soft-Start and Hiccup Restart Timer
- Thermally Enhanced 4-mm x 4-mm QFN-20 Package and 20-pin TSSOP Package

APPLICATIONS

- Half-Bridge, Full-Bridge, Interleaved Forward, and Push-Pull Isolated Converters
- Telecom and Data-com Power
- Wireless Base Station Power
- Server Power
- Industrial Power Systems

DESCRIPTION

The UCC28250 PWM controller is designed for high power density applications that may have stringent pre-biased startup requirements. The UCC28250's integrated synchronous rectifier control outputs target high efficiency and high performance topologies such as half-bridge, full-bridge, interleaved forward, and push-pull. The UCC27200 half bridge drivers and UCC2732X MOSFET drivers used in conjunction with the UCC28250 provide a complete power converter solution.

Externally programmable soft-start, used in conjunction with an internal pre-biased startup circuit, allows the controller to gradually reach a steady-state operating point under all output conditions. The UCC28250 can be configured for primary or secondary-side control and either voltage or current mode control can be implemented.

The oscillator operates at frequencies up to 2 MHz, and can be synchronized to an external clock. Input voltage feedforward, cycle-by-cycle current limit, and a programmable hiccup timer allow the system to stay within a safe operation range. Input voltage, output voltage and temperature protection can be implemented. Dead time between primary-side switch and secondary-side synchronous rectifiers can be independently programmed.

Simplified Application Diagram

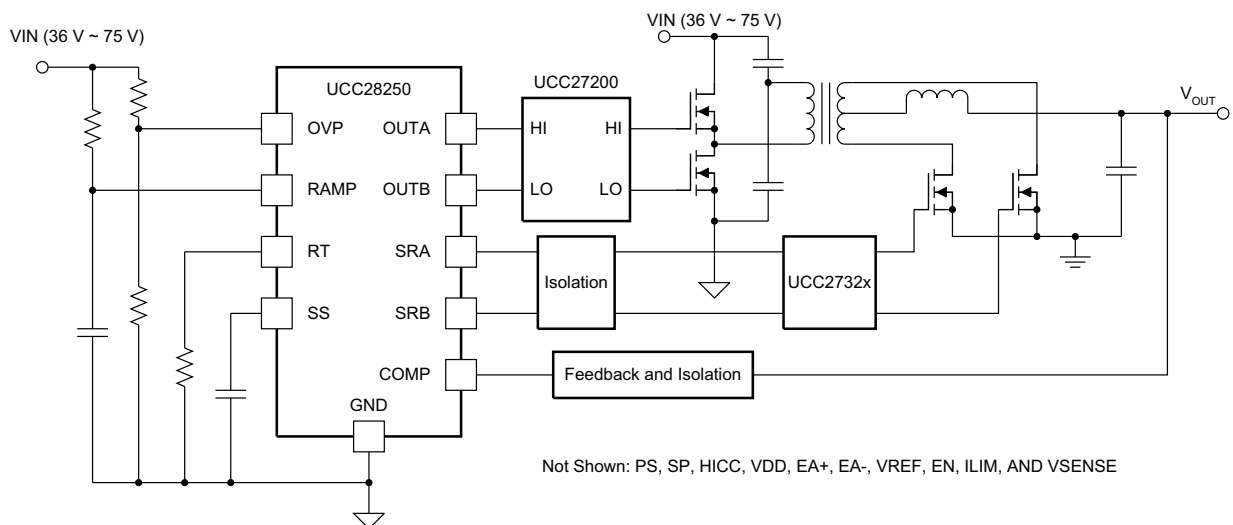

Please be aware that an important notice concerning availability, standard warranty, and use in critical applications of Texas Instruments semiconductor products and disclaimers thereto appears at the end of this data sheet.

ORDERING INFORMATION

TEMPERATURE RANGE $T_A = T_J$	PACKAGE	TAPE AND REEL QTY	PART NUMBER
-40°C to 125°C	Plastic 20-pin QFN (RGP)	250	UCC28250RGPT
		3000	UCC28250RGPR
	Plastic 20-pin TSSOP (PW)	250	UCC28250PWT
		3000	UCC28250PWR

ABSOLUTE MAXIMUM RATINGS

over operating free-air temperature range⁽¹⁾⁽²⁾ (unless otherwise noted)

PARAMETER		VALUE	UNIT
VDD ⁽³⁾	Input supply voltage	-0.3 to 20.0	V
	OUTA, OUTB, SRA and SRB	-0.3 to VDD + 0.3	
	COMP	-0.3 to VREF + 0.3	
	Input voltages on SS and EN	-0.3 to 5.5	
	Input voltages on RT, PS, SP, ILIM, OVP, HICC, VSENSE, EA+ and EA-	-0.3 to 3.6	
	Input voltage on RAMP/CS	-0.3 to 4.3	
	Output voltage on VREF	-0.3 to 3.6	
HBM	ESD rating	3 k	
CDM		2 k	
	Lead temperature (soldering 10 sec) PW package	300	°C

- (1) Stresses beyond those listed under “absolute maximum ratings” may cause permanent damage to the device. These are stress ratings only, and functional operation of the device at these or any other conditions beyond those indicated under “recommended operating conditions” is not implied. Exposure to absolute-maximum-rated conditions for extended periods may affect device reliability.
- (2) These devices are sensitive to electrostatic discharge; follow proper device handling procedures.
- (3) All voltages are with respect to GND unless otherwise noted. Currents are positive into, negative out of the specified terminal. See Packaging Section of the datasheet for thermal limitations and considerations of packages.

THERMAL INFORMATION

THERMAL METRIC	UCC28250	UCC28250	UNITS
	RGP	PW ⁽¹⁾	
	20 PINS	20 PINS	
θ_{JA} Junction-to-ambient thermal resistance ⁽²⁾	126 with hot spot, 104 without hot spot	60.3 with hot spot, 39.3 without hot spot	°C/W
$\theta_{JC(top)}$ Junction-to-case(top) thermal resistance ⁽³⁾		31.5	
θ_{JB} Junction-to-board thermal resistance ⁽⁴⁾		55.8	
$\theta_{JC(bottom)}$ Junction-to-case(bottom) thermal resistance ⁽⁵⁾	0.8		

- (1) For more information about traditional and new thermal metrics, see the *IC Package Thermal Metrics* application report, [SPRA953](#).
- (2) The junction-to-ambient thermal resistance under natural convection is obtained in a simulation on a JEDEC-standard, high-K board, as specified in JESD51-7, in an environment described in JESD51-2a.
- (3) The junction-to-case (top) thermal resistance is obtained by simulating a cold plate test on the package top. No specific JEDEC-standard test exists, but a close description can be found in the ANSI SEMI standard G30-88.
- (4) The junction-to-board thermal resistance is obtained by simulating in an environment with a ring cold plate fixture to control the PCB temperature, as described in JESD51-8.
- (5) The junction-to-case (bottom) thermal resistance is obtained by simulating a cold plate test on the exposed (power) pad. No specific JEDEC standard test exists, but a close description can be found in the ANSI SEMI standard G30-88.

RECOMMENDED OPERATING CONDITIONS

over operating free-air temperature range (unless otherwise noted)

	MIN	TYP	MAX	UNIT
Supply voltage range, V_{DD}	4.7	12	17	V
Supply bypass capacitor, C_{VDD}	1			μF
VREF bypass capacitor	0.5		2	
Error amplifier input common mode range (REF/EA+, FB/EA-)	0		3.0	V
VSENSE input voltage range	0		3.3	
RT resistor range	12.5		200	k Ω
PS, SP resistor range	5		250	
RAMP/CS voltage range	0		2.7	V
Operating junction temperature range	-40		125	$^{\circ}\text{C}$

ELECTRICAL CHARACTERISTICS⁽¹⁾

 $V_{DD} = 12\text{ V}$, 1- μF capacitor from V_{DD} and VREF to GND, $T_A = T_J = -40^{\circ}\text{C}$ to 125°C , $R_T = 75\text{ k}\Omega$ connected to ground to set $F_{SW} = 200\text{ kHz}$ (unless otherwise noted).

PARAMETER		TEST CONDITION	MIN	TYP	MAX	UNITS
Supply Currents						
$I_{DD(\text{off})}$	Startup current	$V_{DD} = 3.6\text{ V}$		150	275	μA
I_{DD}	Operating supply current	100-pF capacitor on OUTA, OUTB, SRA and SRB	2.0	2.7	3.4	mA
$I_{DD(\text{dis})}$	Standby current	EN = 0 V	250	425	600	μA
Under Voltage Lockout						
V_{UVLOR}	Start threshold		4.0	4.3	4.6	V
V_{UVLOF}	Minimum operating voltage after start		3.8	4.1	4.4	
	Hysteresis		0.15	0.20	0.25	
Soft Start						
I_{SS}	Soft-start charge current	$V_{SS} = 0\text{ V}$	25	27	29	μA
$V_{SS(\text{max})}$	Clamp voltage		3.3	3.6	4.0	V
Enable⁽²⁾						
	Trigger threshold				2.25	V
	Minimum pulse width for pulse enable		3			μs
Error Amplifier						
	High-level COMP voltage		2.8	3		V
	Low-level COMP voltage			0.3	0.4	
	Input offset		-12		12	mV
	Open loop gain		70	100		dB
$I_{\text{COMP}(\text{snk})}$	COMP sink current		3.0	6.5	9.0	mA
$I_{\text{COMP}(\text{src})}$	COMP source current		2.0	4.5	8.0	

 (1) Typical values for $T_A = 25^{\circ}\text{C}$.

(2) Refer to EN pin description.

ELECTRICAL CHARACTERISTICS ⁽¹⁾ (continued)

VDD = 12 V, 1- μ F capacitor from VDD and VREF to GND, T_A = T_J = -40°C to 125°C, RT = 75 k Ω connected to ground to set F_{SW} = 200 kHz (unless otherwise noted).

PARAMETER		TEST CONDITION	MIN	TYP	MAX	UNITS
Oscillator						
F _{SW(nom)}	Nominal switching frequency at OUTA or OUTB set by RT resistor	RT/SYNC = 75 k Ω , R _{SP} = 20 k Ω	185	200	215	kHz
F _{SW(min_sync)}	Minimum switching frequency at OUTA or OUTB set by external sync frequency	f _{RT/SYNC} = 100 kHz		85		
F _{SW(max_sync)}	Maximum switching frequency at OUTA or OUTB set by external sync frequency	f _{RT/SYNC} = 2.5 MHz		1.15		MHz
	External synchronization signal high		1			V
	External synchronization signal low				0.2	
Voltage Reference						
V _{VREF}	Output voltage	V _{DD} = from 7 V to 17 V, I _{VREF} = 2 mA	3.22	3.30	3.38	V
		0 < I _{REF} < 10 mA	3.22	3.30	3.38	
	Short circuit current	V _{REF} = 3 V, T _J = 25°C	12	25	40	mA
Current Sense, Cycle-by-Cycle Current Limit With Hiccup						
V _{ILIM}	ILIM cycle-by-cycle threshold		0.495	0.502	0.509	V
T _{PDILIM}	Propagation delay from ILIM to OUTA and OUTB outputs	Exclude leading edge blanking	15	25	36	ns
T _{BLANK}	leading edge blanking		40	60	90	ns
	Current limit shutdown delay timing program current	Measured at HICC pin	55	75	95	μ A
	Hiccup timing program current	Measured at HICC pin	2	2.7	3.5	
V _{HICC_SD}	Current limit shutdown delay timer threshold at HICC		0.55	0.60	0.65	V
V _{HICC_PU}	HICC pull-up threshold		2.3	2.4	2.5	
V _{HICC_RST}	Hiccup restart threshold		0.25	0.30	0.35	
V _{CS(max)}	RAMP/CS clamp voltage	10-V ramp charging voltage source with 40-k Ω current limiting resistor	3.5	4.0	4.5	

ELECTRICAL CHARACTERISTICS ⁽¹⁾ (continued)

VDD = 12 V, 1- μ F capacitor from VDD and VREF to GND, T_A = T_J = -40°C to 125°C, RT = 75 k Ω connected to ground to set F_{SW} = 200 kHz (unless otherwise noted).

PARAMETER		TEST CONDITION	MIN	TYP	MAX	UNITS
OVP/OTP Comparator						
V _{OVP}	Internal reference		0.66	0.70	0.74	V
I _{OVP}	Internal current		8.5	11.0	13.5	μ A
Primary Outputs						
	Rise/fall time	C _{LOAD} = 100 pF		8		ns
R _{SRC}	Output source resistance	I _{OUT} = 20 mA	12	20	35	Ω
R _{SNK}	Output sink resistance	I _{OUT} = 20 mA	4	12	30	
Synchronous Rectifier Outputs						
	Rise/fall time	C _{LOAD} = 100 pF		8		ns
R _{SRC}	Output source resistance	I _{OUT} = 20 mA, VDD = 12 V	12	20	35	Ω
		I _{OUT} = 20 mA, VDD = 5 V	15	25	45	
R _{SNK}	Output sink resistance	I _{OUT} = 20 mA, VDD = 12 V	4	12	30	
TD _{PS}	Primary off to secondary on dead time	PS = VREF	-5.0	0	7.5	ns
		PS = 27 k Ω	27	40	50	
		PS = 27 k Ω , 25°C	37	40	43	
TD _{SP}	Secondary off to primary on dead time	SP = VREF	-5.0	0	7.5	ns
		SP = 20 k Ω	30	40	50	
		SP = 20 k Ω , 25°C	37	40	43	

DEVICE INFORMATION

Functional Block Diagram

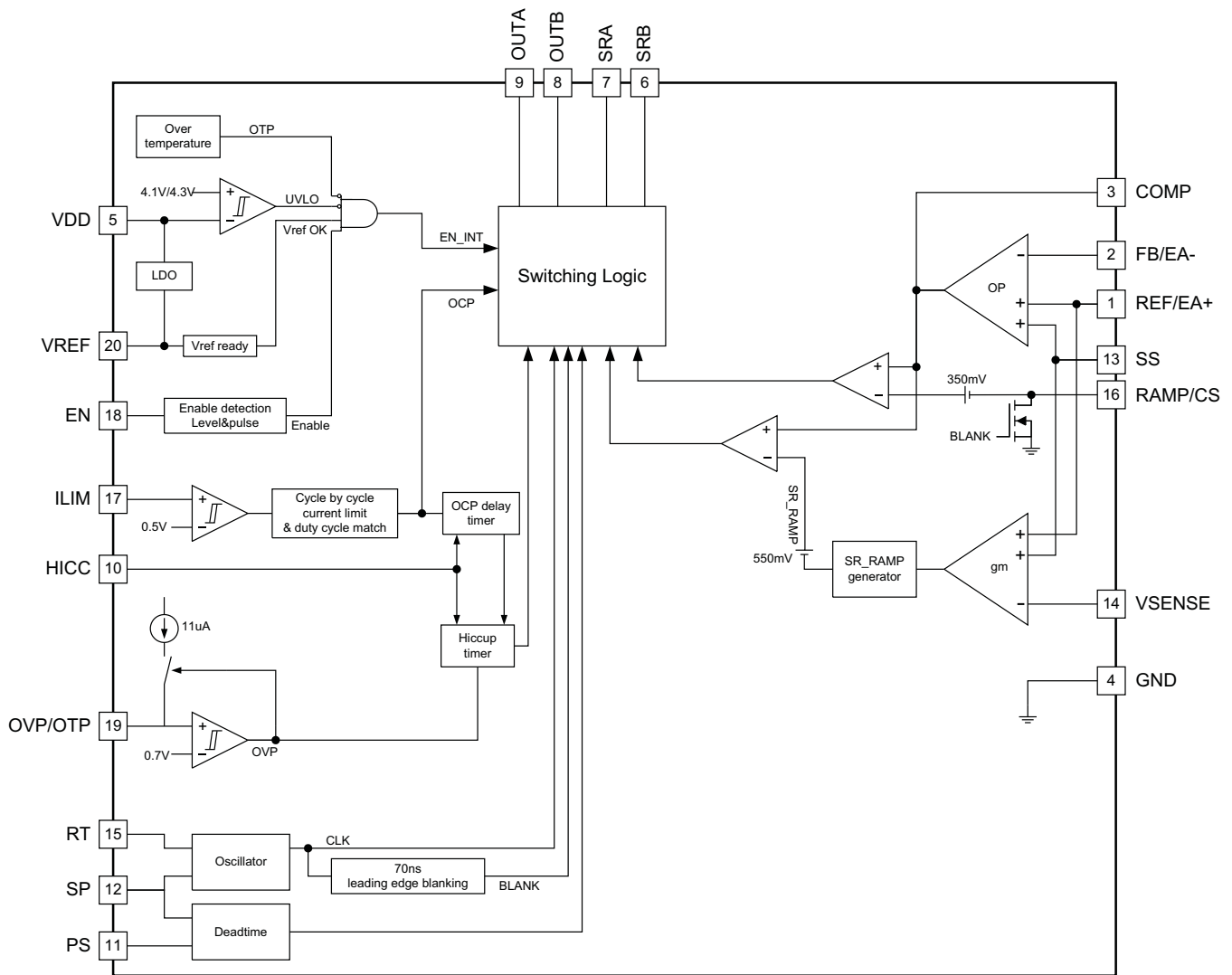

NOTE

Pin numbers are used for RGP package. PW package has different pin numbers.

Typical Application Diagram

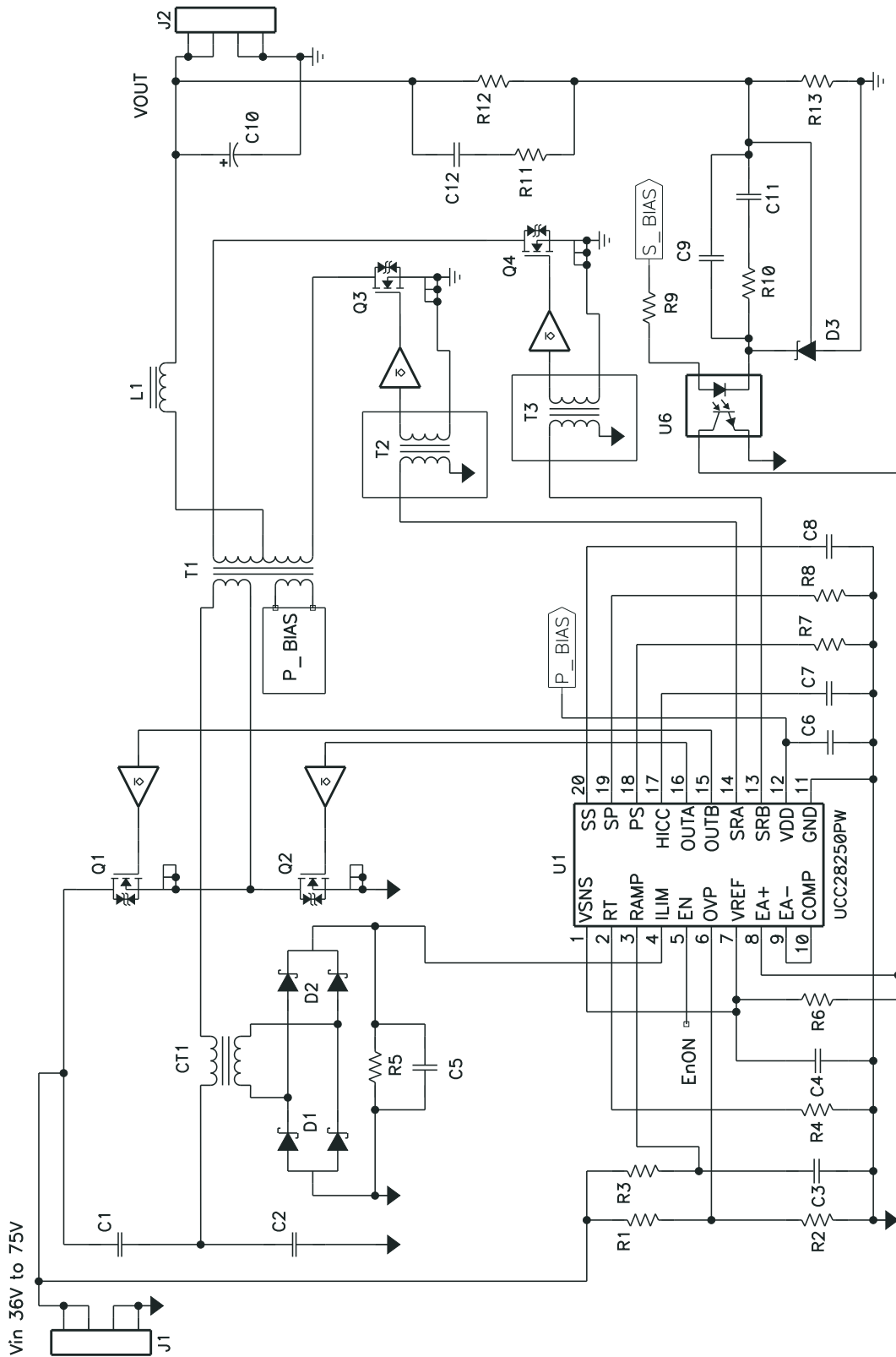

Figure 1. Primary-Side Half-Bridge Controller with Synchronous Rectification

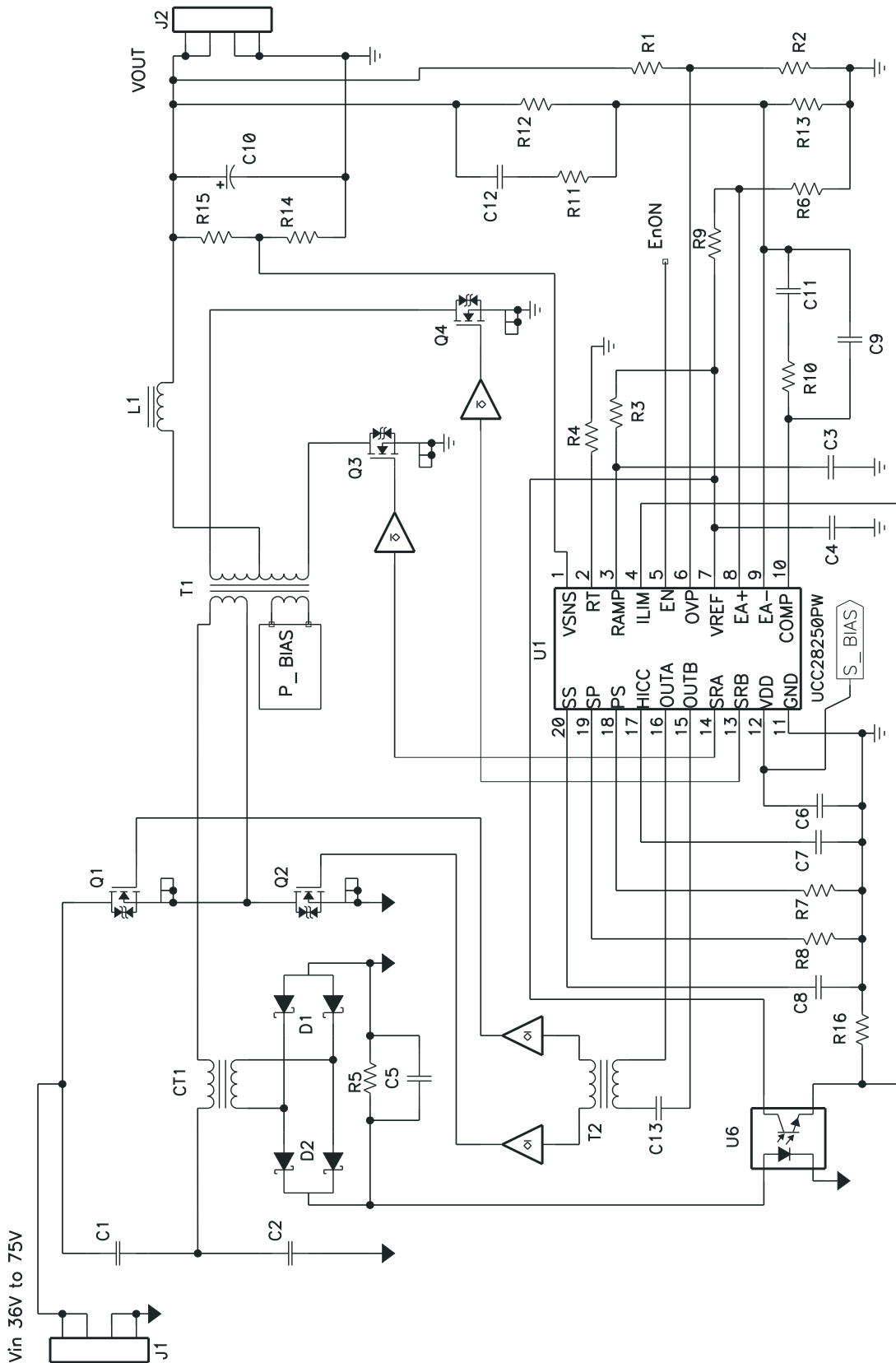
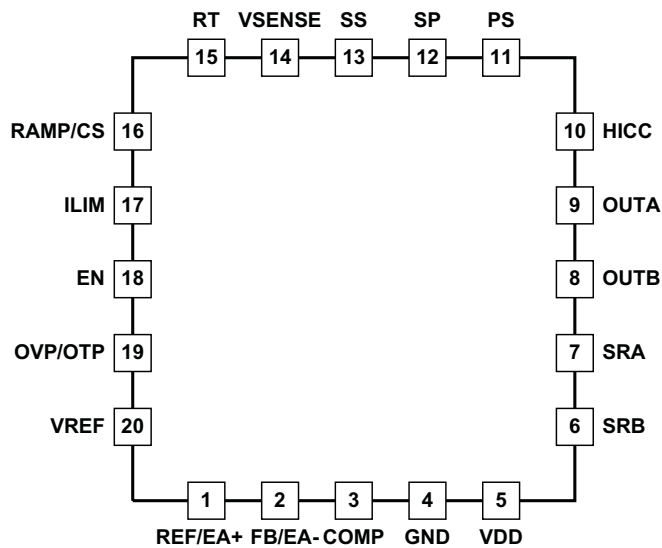

Figure 2. Secondary-Side Half-Bridge Controller with Synchronous Rectification

DEVICE INFORMATION

Pinout Drawings

**QFN-20
TOP VIEW**



**TSSOP-20
TOP VIEW**

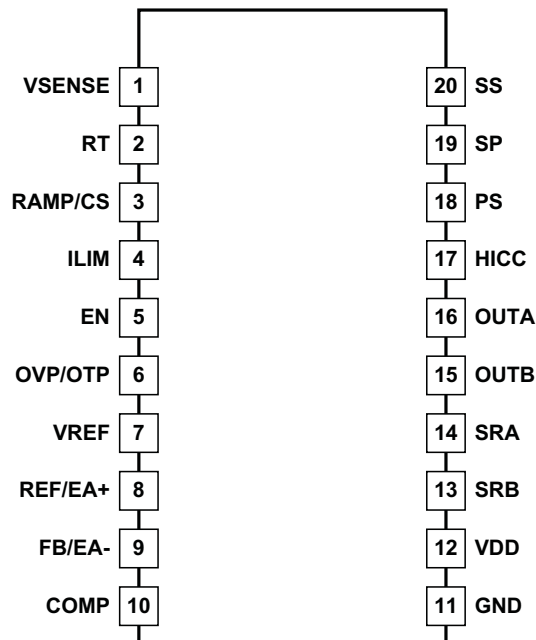

TERMINAL FUNCTIONS

QFN-20	PW-20	NAME	I/O	FUNCTION
5	12	VDD	I	Bias supply input.
20	7	VREF	O	3.3-V reference output.
18	5	EN	I	Device enable and disable.
15	2	RT	I	Oscillator frequency set or synchronous clock input.
12	19	SP	I	Synchronous rectifier off to primary on dead-time set .
11	18	PS	I	Primary off to synchronous rectifier on dead-time set .
16	3	RAMP/CS	I	PWM ramp input (for voltage mode control) or current sense input (for current mode control).
1	8	REF/EA+	I	Error amplifier non-inverting input.
2	9	FB/EA-	I	Error amplifier inverting input.
3	10	COMP	I/O	Error amplifier output.
14	1	VSENSE	I	Output voltage sensing for pre-bias control.
13	20	SS	I/O	Soft-start programming.
17	4	ILIM	I	Current sense for cycle-by-cycle over-current protection.
10	17	HICC	I	Cycle-by-cycle current limit time delay and Hiccup time setting.
19	6	OVP/OTP	I	Over voltage and over temperature protection pin.
9	16	OUTA	O	0.2-A sink/source primary switching output.
8	15	OUTB	O	0.2-A sink/source primary switching output.
7	14	SRA	O	0.2-A sink/source synchronous rectifier output.
6	13	SRB	O	0.2-A sink/source synchronous rectifier output.
4	11	GND	I	Ground.

DETAILED PIN DESCRIPTIONS

VDD (5/12)

The UCC28250 can be powered up by a wide supply range from 4.3 V (UVLO rising typical) to 20 V (absolute maximum), making it suitable for primary-side control or secondary-side control. When the voltage at the VDD pin is lower than 4.1 V (typical), the controller is in stand-by mode and consumes 150 μ A (typical) at 3.6 V VDD. In stand-by mode, VREF continues to be regulated to 3.3 V or follows VDD if VDD is lower than 3.3 V. Please refer to the VREF description for more detailed information. A minimum 1- μ F bypass capacitor is required from VDD to ground. Keep the bypass capacitor as close to the device as possible.

VREF (Reference Generator) (20/7)

The VREF pin is regulated at 3.3 V. An external ceramic capacitor must be placed as close as possible to the VREF and GND pins for noise filtering and to provide compensation to the regulator. The capacitance range must be limited between 0.5 μ F to 2 μ F for stability. This reference is used to power the controller's internal circuits, and can also be used to bias an opto-coupler transistor, an external house-keeping microcontroller, or other peripheral circuits. This reference can also be used to generate the reference for an external error amplifier. This regulator output is internally current limited to 25 mA (typical).

EN (Enable Pin) (18/5)

The following conditions must be met before the controller allows start up:

1. VDD voltage is above the rising UVLO threshold 4.3 V (typical);
2. The 3.3-V reference voltage output at the VREF pin is available and above 2.4 V (typical);
3. Junction temperature is below the thermal shutdown threshold 130°C (minimum);
4. The voltage at OVP is below 0.7 V (typical).

If all these conditions are met, the signal driving the EN pin is able to initiate the soft start process. Once the device is enabled, the 27- μ A internal charging current at the SS pin is turned on and begins to charge the soft-start capacitor. The EN pin can accept both level-enable and pulse-enable signals.

For level-enable, the voltage level on the EN pin needs to be continuously higher than 2.25 V to allow continuous operation. Once the EN pin falls below 2.25 V, the device is disabled (see [Figure 3](#)).

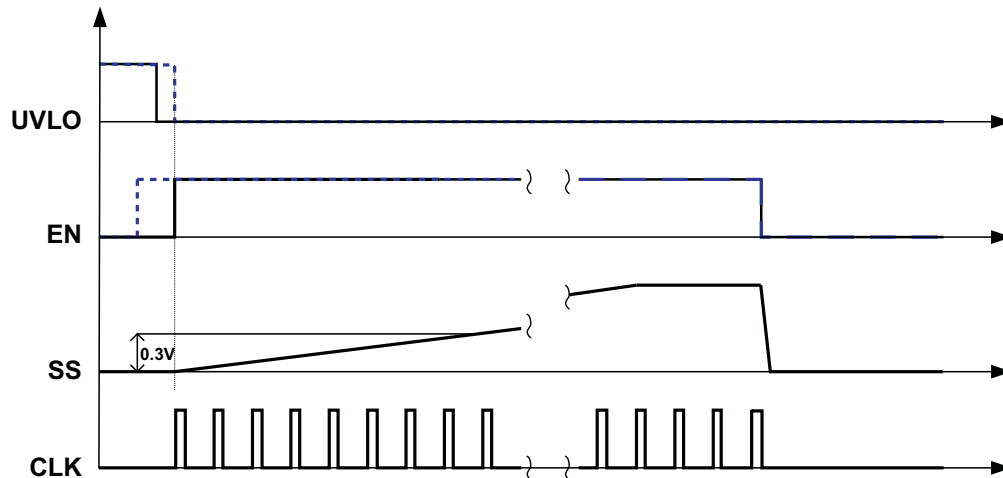

Figure 3. Level Enable at EN pin

A pulse signal may also be applied to the EN pin. Pulse-enable operation is shown on Figure 4. If the EN falling edge happens before the SS voltage reaches 0.3 V, the enable signal at EN pin is considered as a pulse. In this case, the next rising edge at EN pin disables the controller. If the falling edge of the first pulse at EN pin happens after SS rises to 0.3 V, the UCC28250 interprets the pulse enable as a level enable, and an external solution as shown on Figure 5 (a) can be used to reduce the pulse width. In this circuit, R2 is used to limit the current (especially the negative current) through the internal ESD cell. Figure 5 (b) illustrates the waveforms based on this solution. To prevent false trigger by noises, the pulse at the EN pin must be at least 2.25 V (minimum) high and 3 μs wide to be considered valid.

Choose the R1, R2, and C values based on the following equations:

Choose R2 based on the current limit requirement from the device.

$$R_2 > 10k\Omega \tag{1}$$

Choose R1 arbitrarily but much smaller than R2 and choose C1 according to the time constant requirement to generate longer than 3-μs pulse.

$$C_1 = \frac{6\mu s}{R_1} \tag{2}$$

If enable function is not used, pull EN pin to VREF.

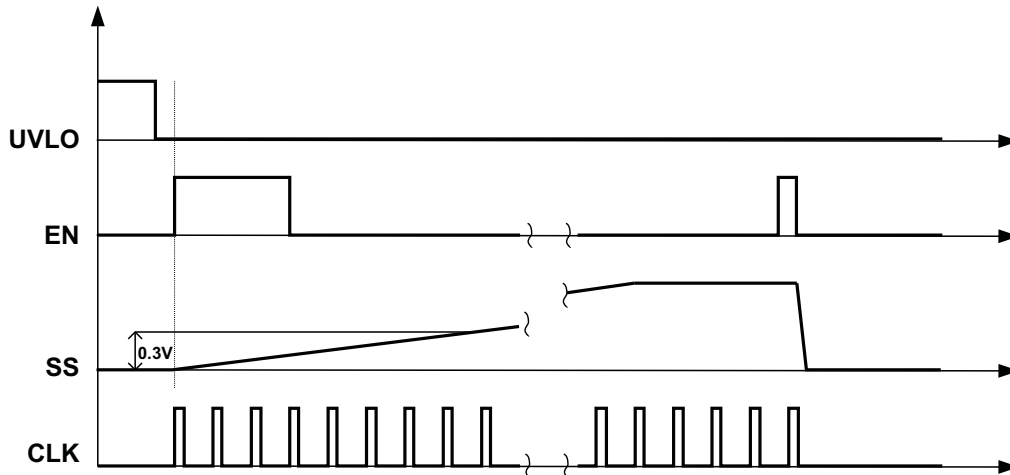

Figure 4. Pulse Enable at EN Pin

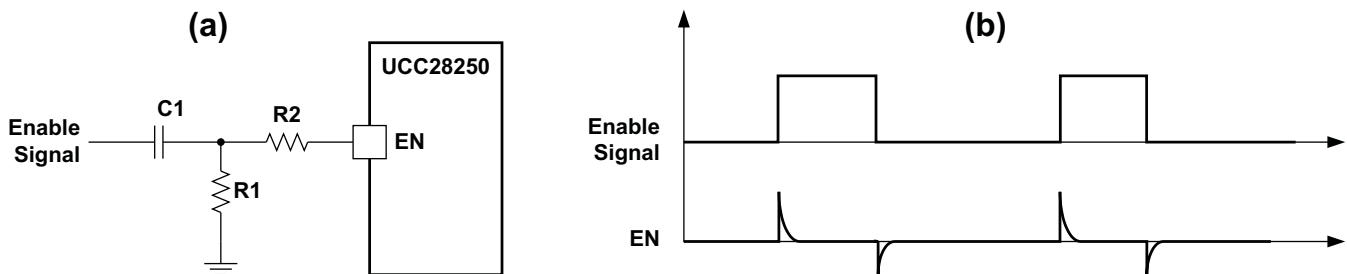

Figure 5. An External Solution to Generate Enable Pulses for Pulse Enable

RT (Oscillator Frequency Set and Synchronization) (15/2)

The UCC28250 oscillator frequency is set by an external resistor connected between the RT pin and ground. Switching frequency selection is a trade-off between efficiency and component size. Based on the selected switching frequency, the programming resistor value can be calculated as:

$$R_T = \frac{1}{2 \times f_{SW}} - T_{d(SP)} \quad (3)$$

33.2pF

In this equation, f_{SW} is the switching frequency and $T_{D(SP)}$ is the dead time between synchronous rectifier turn-off to primary switch turn-on. $T_{D(SP)}$ is set by an external resistor between the SP pin and ground (refer to the SP pin description).

Each output (OUTA, OUTB, SRA, SRB) switches at half the oscillator frequency ($f_{SW} = \frac{1}{2} \times f_{OSC}$). Figure 6 shows the relationship between RT and f_{OSC} at certain $T_{D(SP)}$ and can be used to program oscillator frequency accordingly.

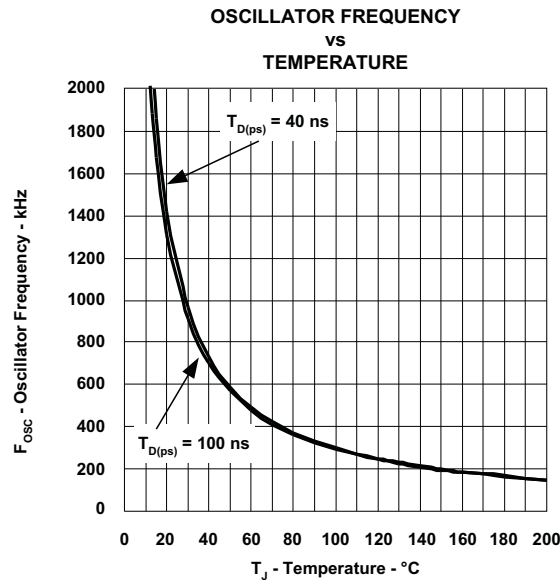

Figure 6. Oscillator Frequency F_{OSC} vs External Resistance of RT at $T_{D(ps)} = 40$ ns and 100 ns

The UCC28250 can be synchronized to an external clock by applying an external clock source to the RT pin. Synchronization helps with parallel operation and/or preventing beat frequency noise. The UCC28250 synchronizes its internal oscillator to an external frequency source ranging from 170 kHz to 2.3 MHz, which is equivalent to an 85-kHz to 1.15-MHz switching frequency. The internal oscillator frequency is clamped to 170 kHz during synchronization if the external source frequency drops below 170 kHz.

The UCC28250 aligns the turn-on of primary outputs OUTA and OUTB to the falling edge of the synchronizing signal, as shown in Figure 7. If the frequency source is from the gate outputs of another half bridge controller, interleaving can be achieved. The interleaving angle is determined by the frequency source's duty cycle. When a 50% duty cycle is applied, optimal interleaving is achieved, and EMI filters can be minimized.

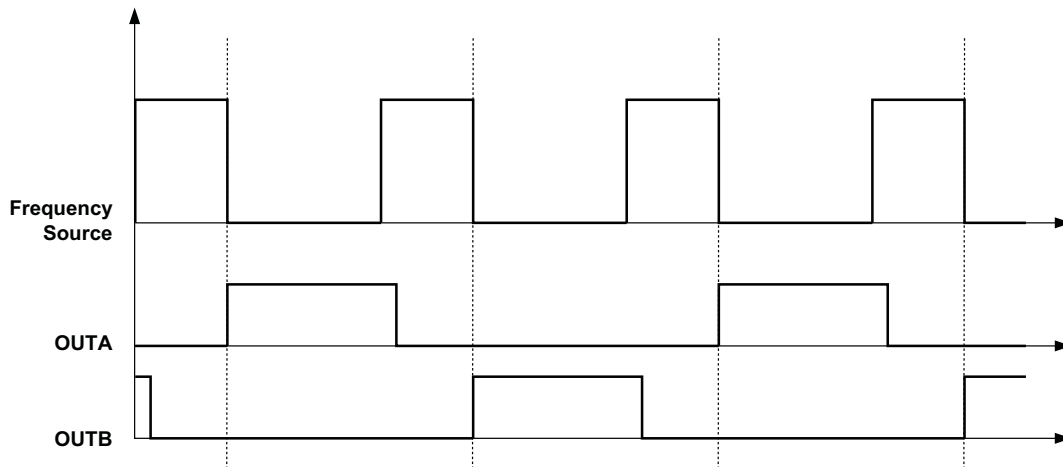

Figure 7. Timing Diagram for Synchronization

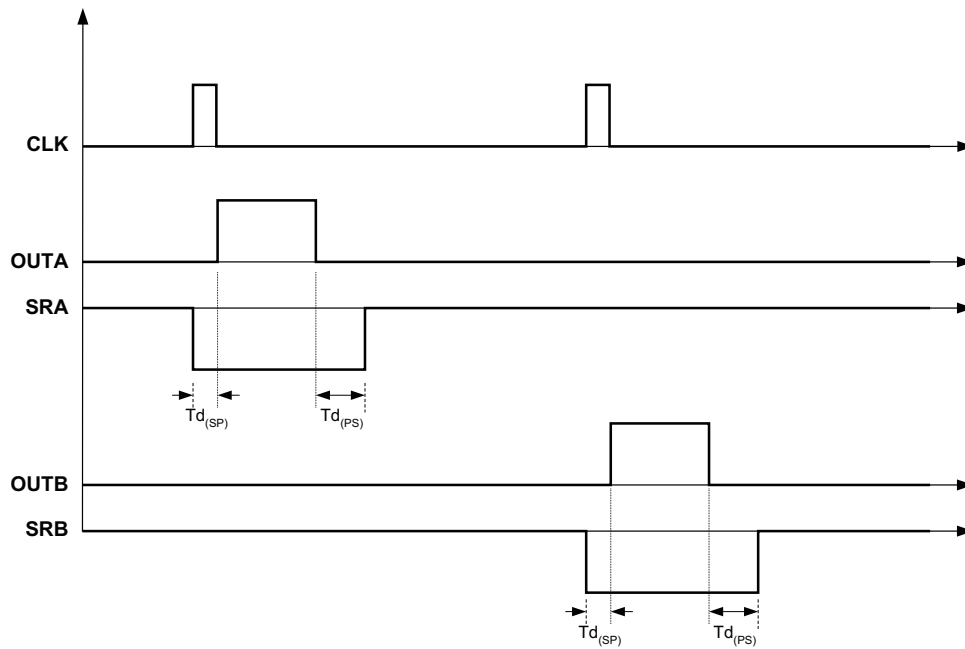

Figure 8. UCC28250 Outputs Timing Waveforms

SP (Synchronous Rectifier Turn-Off to Primary Output Turn-On Dead Time Programming) (13/19)

The dead time $T_{D(SP)}$ between synchronous rectifier turn-off to primary output turn-on is programmed by an external resistor, R_{SP} , connected between the SP pin and ground. The value of R_{SP} can be determined by Figure 9. Zero dead time can be achieved by tying the SP pin to VREF. The falling edge of synchronous rectifier SRA/SRB is aligned with the raising edge of the primary output OUTA/OUTB.

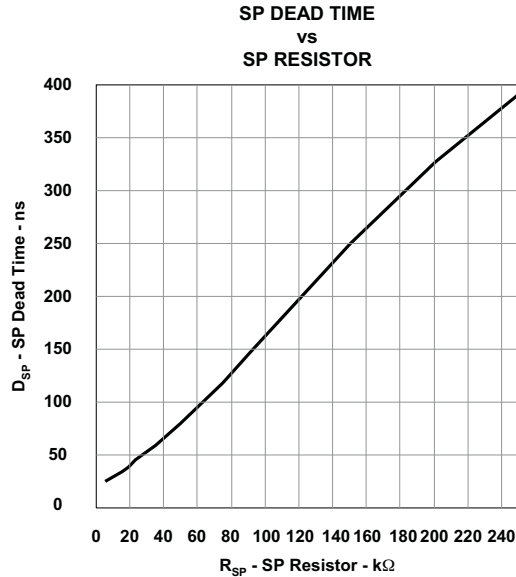

Figure 9. Dead Time $T_{D(SP)}$ vs. External Resistor R_{SP} at SP Pin

PS (Primary Output Turn-Off to Synchronous Rectifier Turn-On Dead Time Programming) (11/18)

The dead time $T_{D(PS)}$ between primary output turn-off to synchronous rectifier turn-on is set by external resistor, R_{PS} , connected between PS pin and ground. The value of R_{PS} is defined by Figure 10. Zero dead time can be achieved by tying the PS pin to VREF.

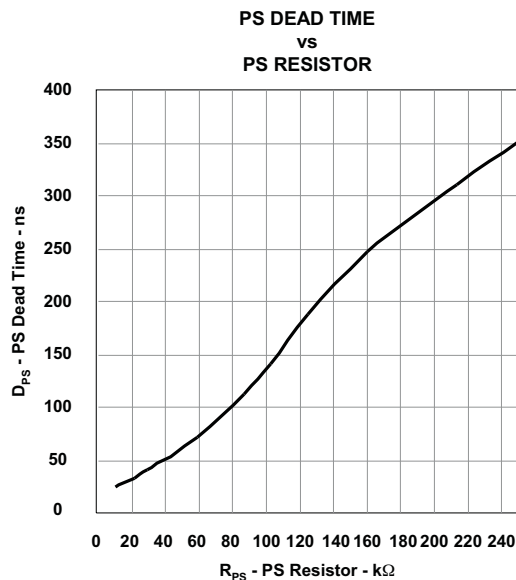

Figure 10. Dead Time $T_{D(PS)}$ vs. External Resistor R_{PS} at PS Pin

RAMP/CS (PWM Ramp Input or Current Sense Input) (16/3)

The UCC28250 can be controlled using either voltage mode or current mode. RAMP/CS is a multi-function pin used either to generate the ramp signal for voltage mode control or to sense current for current mode control. The following sections describe the RAMP/CS functionality for voltage mode and current mode control.

RAMP: Voltage Mode Control with Feed-Forward Operation

For voltage mode control, a resistor R_{CS} and a capacitor C_{CS} must be connected to the RAMP/CS pin as shown in Figure 11. The internal pull-down switch has approximately 40- Ω on-resistance. The RAMP/CS pin is clamped internally to 4 V for internal device protection. The C_{CS} value must be small enough to discharge the RAMP/CS pin from its peak voltage to ground within the pulse width of the BLANK signal ($T_{D(SP)} + 70$ ns). The following formula derives a C_{CS} value.

$$C_{CS} < \left(\frac{4V/2}{40\Omega} \right) \times \frac{T_{d(SP)} + 70ns}{4V} \quad (4)$$

A C_{CS} value less than 650 pF works for most applications. In order to minimize the impacts of parasitic capacitance caused by the PCB layout and routing, a minimum of 100 pF is recommended for C_{CS} . Once C_{CS} is determined, R_{CS} can be calculated according to the desired ramp peak amplitude.

$$R_{CS} = \frac{1}{2 \times \ln \left(\frac{V_{CHARGE}}{V_{CHARGE} - V_{PK}} \right) \times C_{CS} \times f_{SW}} \quad (5)$$

In this equation, the V_{CHARGE} is the voltage used to generate the ramp, V_{PK} is the desired ramp amplitude and the f_{SW} is the switching frequency.

Choose the ramp amplitude to accommodate the voltage range of the COMP pin and the maximum duty cycle required by the power stage. Use the following equation to select V_{PK} , in the equation, D_{MAX} is the maximum duty cycle for primary outputs.

$$V_{PK} = \frac{1.4V}{D_{MAX}} \quad (6)$$

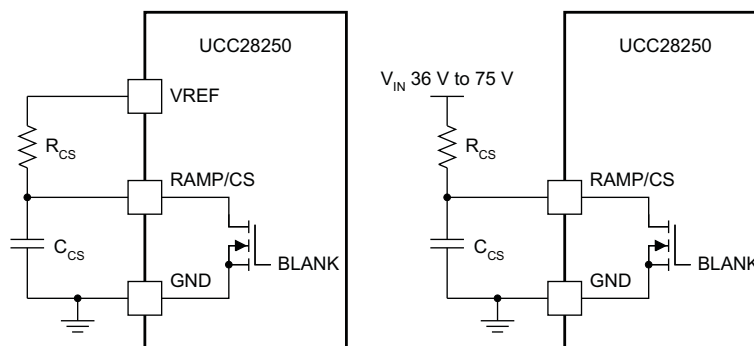

Figure 11. Fixed Ramp Generation/Ramp Generation With Input Voltage Feedforward

Voltage feed-forward can be achieved by driving R_{CS} from line input V_{IN} . The peak of RAMP/CS is proportional to V_{IN} and output has much faster line transient response. When the UCC28250 is used for the primary-side control, RAMP parameters are critical for the optimal pre-biased start up performance. Refer to the 'Voltage Mode Control and Input Voltage Feed-Forward' section of the Functional Description section for a detailed design procedure of choosing R_{CS} .

If the line input cannot be easily accessed due to limited board area or other limitation, a RAMP signal with fixed peak voltage can be implemented by simply driving R_{CS} from 3.3 V VREF (Figure 11).

CS: Current Mode Control

For current mode control, the RAMP/CS pin is driven by a signal representative of the transformer primary-side current. The current signal has to have compatible input range of the COMP pin. As shown in Figure 12, the COMP pin voltage is used as the reference for peak current. The primary-side signals OUTA and OUTB are turned on by the internal clock signal and turned off when sensed peak current reaches the COMP pin voltage. Choose the current sense transformer turns ratio (1:n) and the burden resistor value (R_B) based on the peak current at maximum load I_{MAX}. Refer to the Functional Description section for more details on the current mode control.

$$R_B = \frac{3V}{I_{MAX} / n} \tag{7}$$

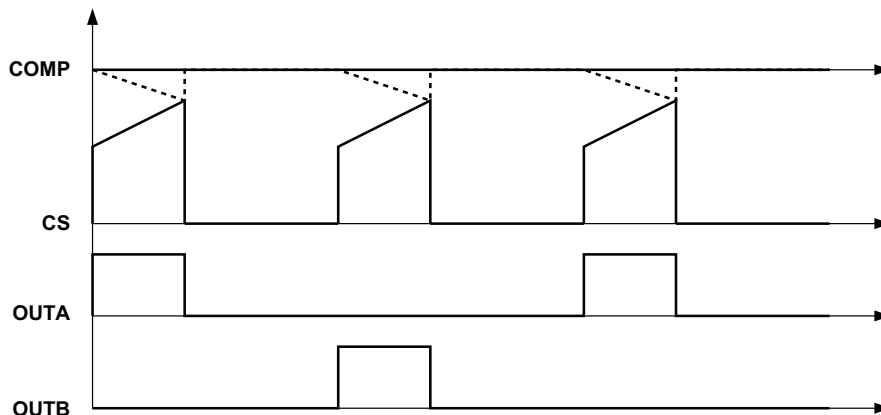

Figure 12. Peak Current Mode Control and PWM Generation

REF/EA+ (1/8)

REF/EA+ is the non-inverting input of the UCC28250’s internal error amplifier.

When the UCC28250 is configured for secondary-side control, the internal error amplifier is used as the control loop error amplifier. Connect REF/EA+ directly to the VREF pin to provide the reference voltage for the feedback loop.

When the UCC28250 is configured for primary-side control, the error amplifier is connected as a voltage follower. Connect REF/EA+ to the opto-coupler output.

The voltage range on REF/EA+ pin is 0 V to 3.7 V.

FB/EA- (2/9)

FB/EA- is the inverting input of the UCC28250's internal error amplifier.

When the UCC28250 is configured for secondary-side control, connect the output voltage sensing divider to this pin. The voltage divider can be selected according to the voltage on REF/EA+ pin. Referring to [Figure 13](#), pick the lower resistor R_{O1} value arbitrarily, and choose the upper resistor R_{O2} value as:

$$R_{O2} = \left(\frac{V_o}{V_{REF/EA+}} - 1 \right) \times R_{O1} \quad (8)$$

Because the control loop gain is affected by voltage divider resistor values, choose an appropriate R_{O1} value so that the voltage loop DC gain is larger than 40 dB to prevent interference between the primary-side control loop and the SR control loop during start up.

When the UCC28250 is sitting on the primary side, the error amplifier is connected as a voltage follower. Connect FB/EA- directly with COMP pin.

The maximum voltage allowed on FB/EA- pin is 3.7 V.

COMP (3/10)

The COMP pin is the internal error amplifier's output. The voltage range of COMP pin is 0 V to 3 V. Both the primary-side switches' duty cycle and secondary-side SRs' duty cycle is controlled by the COMP pin voltage. At steady state, a higher COMP pin voltage results in a larger duty cycle for the primary-side switches and a smaller duty cycle on the SRs.

When the UCC28250 controller is set up for secondary-side control, connect the compensation network from the FB/EA- pin to the COMP pin.

For primary-side control, the error amplifier is connected as a voltage follower. Directly connect the COMP pin to the FB/EA- pin.

VSENSE (14/1)

The VSENSE pin is used to directly sense the output voltage and to feed it into a transconductance error amplifier. The measured voltage allows the UCC28250 to achieve optimal pre-biased start up performance.

When configured as a secondary-side controller, the output voltage is sensed and fed into the FB/EA- pin. The UCC28250 uses a conventional error amplifier approach to allow type III compensation. Therefore, the FB/EA- pin voltage always follows the REF/EA+ voltage. The FB/EA- pin does not reflect the true output voltage and therefore this dedicated VSENSE pin is required. The voltage divider connected to VSENSE is discussed in the Pre-Biased Start-Up Section.

When UCC28250 is set up as primary-side control, connect VSENSE pin to VREF.

SS (Soft Start Programming Pin) (13/20)

The soft-start circuit gradually increases the converter's output voltage until steady state operation is reached. This reduces start-up stresses and current surge.

When the UCC28250 reaches its valid operating threshold, the SS pin capacitor is charged with a 27-μA current source. The UCC28250's internal error amplifier non-inverting terminal follows the SS pin voltage on REF/EA+ pin voltage depending on which one is lower. Hence, during soft start, the SS pin voltage is lower than REF/EA+. The internal error amplifier then uses the SS pin as its reference voltage, until the SS pin voltage rises above the REF/EA+ level. Once the SS pin voltage is above REF/EA+ voltage, soft-start time is considered finished.

The soft-start implementation scheme and timing is different, depending on the location of the UCC28250 with respect to the isolation barrier.

For secondary-side control, the internal error amplifier is used to achieve the voltage regulation. The REF/EA+ is connected to an external reference voltage, FB/EA- is connected to the voltage sensing divider, and the error amplifier's output pin (COMP) is connected through a compensation filter back to the FB/EA- pin (Figure 13). In this case, the primary output's start-up is a closed loop soft start (soft-start input reference of error amplifier). The output soft-start time is determined by the external capacitor connected at SS pin based on the internal 27-μA charging current and the voltage set at REF/EA+ pin.

Based on the soft-start time T_{SS} , choose soft start capacitor C_{SS} value as:

$$C_{SS} = \frac{27 \mu A \times T_{SS}}{V_{REF/EA+}} \tag{9}$$

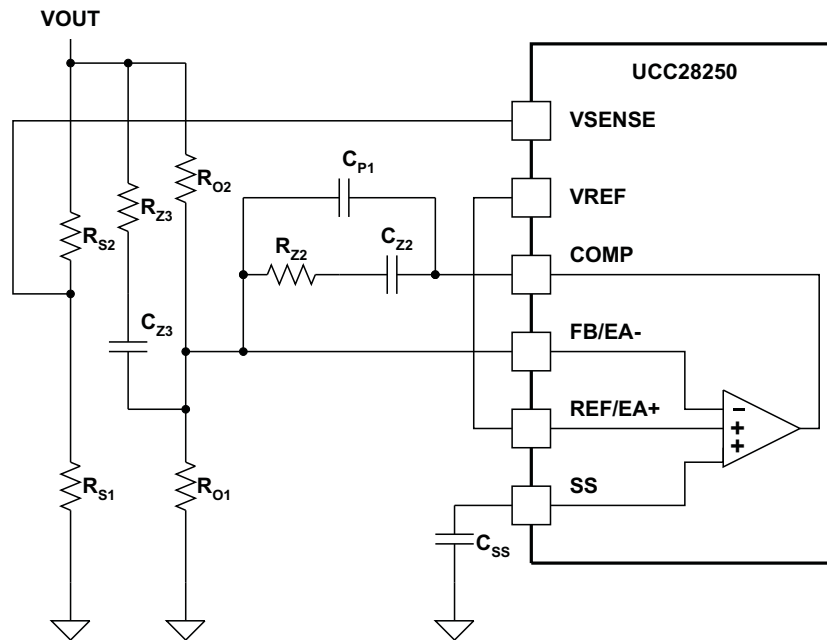

Figure 13. Error Amplifier EAMP Connections for secondary-side Control

For primary-side control, the internal error amplifier is connected as a buffer stage. In other words, the COMP pin is shorted to the FB/EA- pin, and the output of an external error amplifier is connected to the REF/EA+ pin through an optical coupler (Figure 14). In this case, the output start-up is an open loop soft start because the COMP follows the soft-start voltage instead of the voltage loop output. The soft-start time is still determined by external capacitor C_{SS} and the 27-μA internal charge current. The voltage depends on the value of final COMP voltage which corresponds to the regulated primary output duty cycle. According to the desired soft start time and COMP pin voltage level at steady state, the SS pin capacitor can be calculated as:

$$C_{SS} = \frac{27 \mu A \times T_{SS}}{V_{COMP_final}} \tag{10}$$

After soft start, the voltage at SS pin is eventually clamped at around 4 V. Under fault conditions (UVLO, internal thermal shut down, OVP/OTP, hiccup mode), or when externally disabled, SS pin is pulled down to ground quickly by an internal switch with 2 kΩ on resistance to prepare for re-start. Pulling SS pin to ground externally shuts down the controller as well.

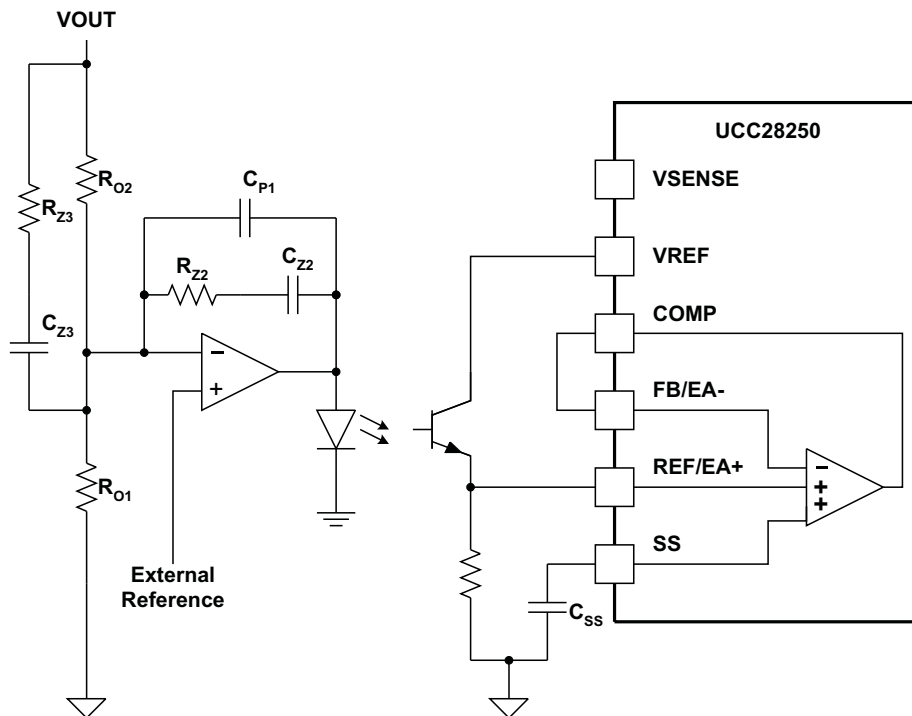

Figure 14. Error Amplifier EAMP Connections for primary-side Control

ILIM (Current Limit for Cycle-By-Cycle Over-Current Protection) (17/4)

Cycle-by-cycle current limit is accomplished using the ILIM pin for current mode control or for voltage mode control. The input to the ILIM pin represents the primary current information. If the voltage sensed at ILIM pin exceeds 0.5 V, the current sense comparator terminates the pulse of output OUTA or OUTB. If the high current condition persists, the controller operates in a cycle-by-cycle current limit mode with duty cycle determined by the current sense comparator instead of the PWM comparator. ILIM pin is pulled down by an internal switch at the rising edge of every clock cycle. This internal switch remains on for an additional 70 ns after OUTA or OUTB goes high to blank leading edge transient noise in the current sensing loop. This reduces the filtering requirements at the ILIM pin and improves the current sense response time.

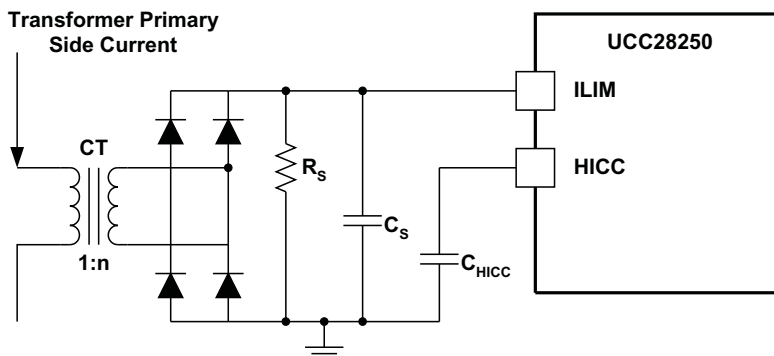

Figure 15. Current Limit Circuit

Once the over current protection level I_{PK} is selected, the current transformer turns ratio and the burden resistor value can be decided as:

$$R_s = \frac{0.5V \times n}{I_{PK}} \tag{11}$$

In this equation, current transformer turns ratio is 1:n and R_s is the burden resistor value.

Some filtering capacitance is required to reduce the sensing noise. Choose the RC constant at about 100 ns, and calculate the capacitor value as:

$$C_s = \frac{100ns}{R_s} \tag{12}$$

The cycle-by-cycle current limit operation time before all four outputs shut down can be programmed by external capacitor C_{HICC} at HICC pin. (See HICC pin description)

HICC (10/17)

The cycle-by-cycle current limit operation time before all four outputs shut down can be programmed by an external capacitor C_{HICC} from HICC pin to ground, as shown in Figure 15. Once all four outputs are shutdown, controller goes into hiccup cycle which is about 100 times of the cycle-by-cycle current limit shut-down delay time. A 1-mA internal current source charges HICC pin up to 2.4 V, then the HICC pin is discharged by a 2.7- μ A internal current source to generate long hiccup restart time until HICC reaches 0.3 V. Based on the system requirement, once the cycle-by-cycle current limit delay time $T_{OC(delay)}$ is selected, the HICC pin capacitor C_{HICC} can be selected based on the equation

$$C_{HICC} = \frac{T_{OC(delay)} \times 75 \mu A}{0.6 V} \quad (13)$$

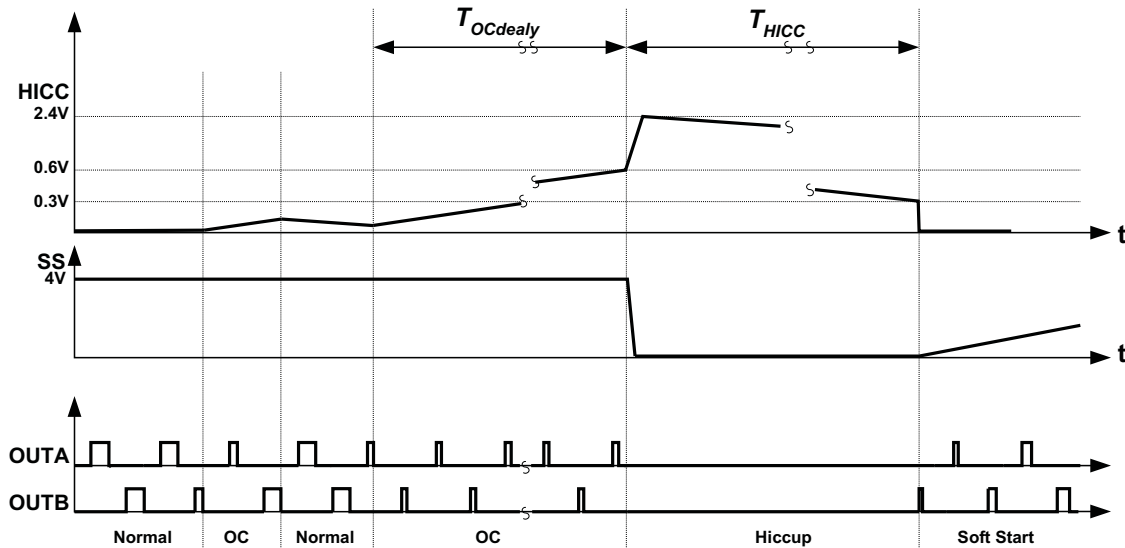

Figure 16. Cycle-by-Cycle Current Limit Delay Timer and Hiccup Restart Timer

As shown in Figure 16, cycle-by-cycle current limiting shut-down delay time is:

$$T_{OC(delay)} = C_{HICC} \times \frac{0.6 V}{75 \mu A} \quad (14)$$

And hiccup-restart-time T_{HICC} is equal to:

$$T_{HICC} = C_{HICC} \times \frac{2.4 V - 0.3 V}{2.7 \mu A} \quad (15)$$

As soon as the outputs are shut-down, the SS pin is pulled to ground internally until the hiccup restart timer is reset after time duration T_{HICC} .

OVP/OTP (19/6)

The OVP/OTP pin provides multiple fault protection functions. If the voltage on the OVP/OTP pin exceeds 0.7 V, a fault shutdown occurs. All outputs stop switching and stay off (low) during the shutdown, and the SS pin is pulled to ground internally. Once the fault condition is cleared (i.e. OVP/OTP voltage drops below 0.7 V), the UCC28250 enters hiccup mode. A soft-start cycle begins after the hiccup cycle is finished. An internal 11-μA switched current source is used to create hysteresis.

If the external resistor divider runs from line voltage VIN, a line over voltage protection is implemented.

If the external resistor divider runs from the output voltage, output over voltage fault protection is achieved. Figure 17 shows the over-voltage protection external configuration at the OVP/OTP pin.

According to the protection threshold VR and recovery threshold VF, choose an arbitrary R2 value. To ensure a realistic solution, R2 needs to meet the following:

$$R_2 < \frac{0.7 \text{ V} \times (V_R - V_F)}{11 \mu\text{A} \times (V_R - 0.7 \text{ V})} \quad (16)$$

The other two resistors, R1 and R3 can be calculated.

$$R_1 = \frac{V_R - 0.7 \text{ V}}{0.7 \text{ V}} \times R_2 \quad (17)$$

$$R_3 = \frac{0.7 \text{ V} \times (V_R - V_F) - 11 \mu\text{A} \times R_2 \times (V_R - 0.7 \text{ V})}{11 \mu\text{A} \times V_R} \quad (18)$$

If the external resistor divider runs from 3.3-V VREF, and replaces R2 with a positive temperature coefficient (PTC) thermistor, an over temperature fault protection with programmable hysteresis is accomplished (Figure 18). Choose an arbitrary PTC value, which has a resistance as RPTC1 at protection temperature and resistance as RPTC2 at recovery temperature. Because of its positive temperature coefficient, RPTC1 is larger than RPTC2. To ensure an available solution, RPTC1 and RPTC2 need to meet the criteria.

$$0.7 \text{ V} \times (R_{\text{PTC1}} - R_{\text{PTC2}}) - 11 \mu\text{A} \times R_{\text{PTC1}} \times R_{\text{PTC2}} \geq 0 \quad (19)$$

And resistors R1 and R3 can be calculated as:

$$R_1 = 3.7 \times R_{\text{PTC1}} \quad (20)$$

$$R_3 = \frac{2.6 \text{ V} \times [0.7 \text{ V} \times (R_{\text{PTC1}} - R_{\text{PTC2}}) - 11 \mu\text{A} \times R_{\text{PTC1}} \times R_{\text{PTC2}}]}{11 \mu\text{A} \times (2.6 \text{ V} \times R_{\text{PTC1}} + 0.7 \text{ V} \times R_{\text{PTC2}})} \quad (21)$$

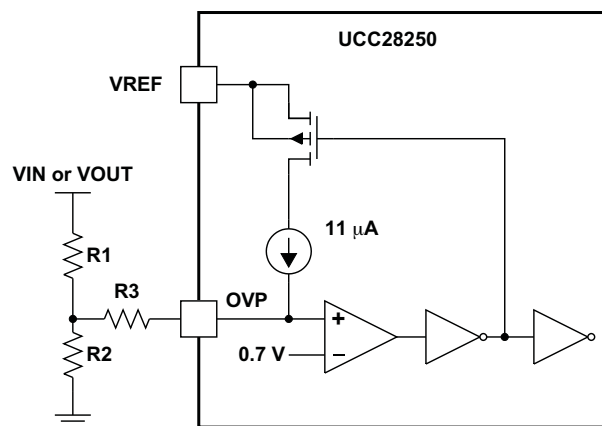

Figure 17. Over Voltage Protection

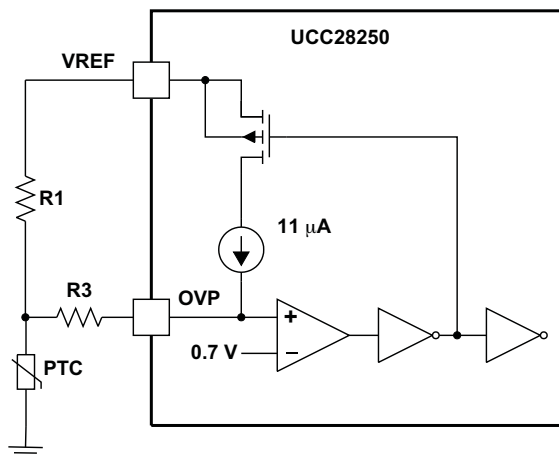

Figure 18. Over Temperature Protection

Figure 19 shows an external configuration using the OVP/OTP pin to achieve both over-voltage and over temperature protection. Follow the same design procedure for the OVP setting to choose R₁, R₂, and R₃. Choose an NTC value at protection temperature much smaller than R₁ and with the resistance at protection temperature as R_{NTC1}, and recover temperature as R_{NTC2}. The R₄ value can be calculated as:

$$R_4 = \frac{0.7\text{ V}}{3.3\text{ V} - 0.7\text{ V}} \times R_{\text{NTC1}} \tag{22}$$

Because of the interaction between the two voltage dividers, over temperature protection thresholds move slightly with the different input voltages.

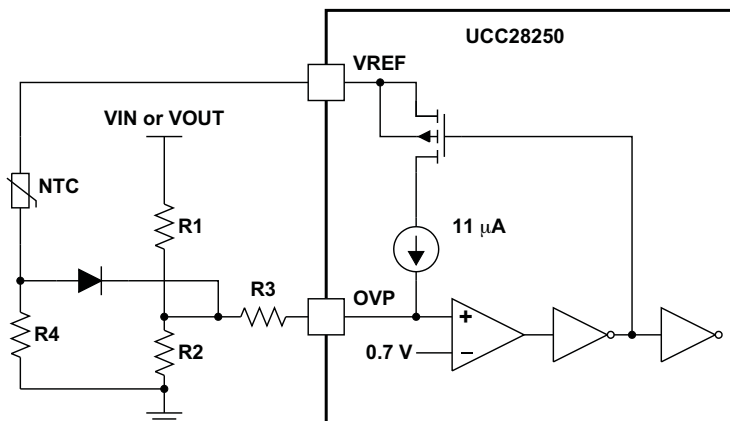

Figure 19. Over Voltage and Over Temperature Protection With Single OVP Pin

OUTA (9/16) and OUTB (8/15)

OUTA and OUTB are the primary-side switch control signals. With the 0.2-A peak current capability, an external gate driver is required.

SRA (7/14) and SRB (6/13)

SRA and SRB are the synchronous rectifier control signals. With the 0.2A peak current capability, an external gate driver is required.

GND (4/11)

GND pin is the ground reference for the whole device. Tie all the signal returns to this pin.

TYPICAL CHARACTERISTICS

START-UP CURRENT
vs
TEMPERATURE

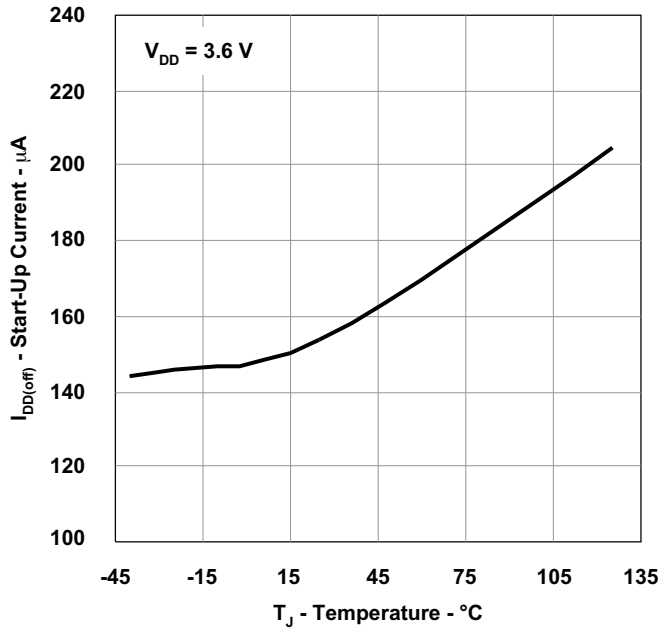

Figure 20.

STAND-BY CURRENT
vs
TEMPERATURE

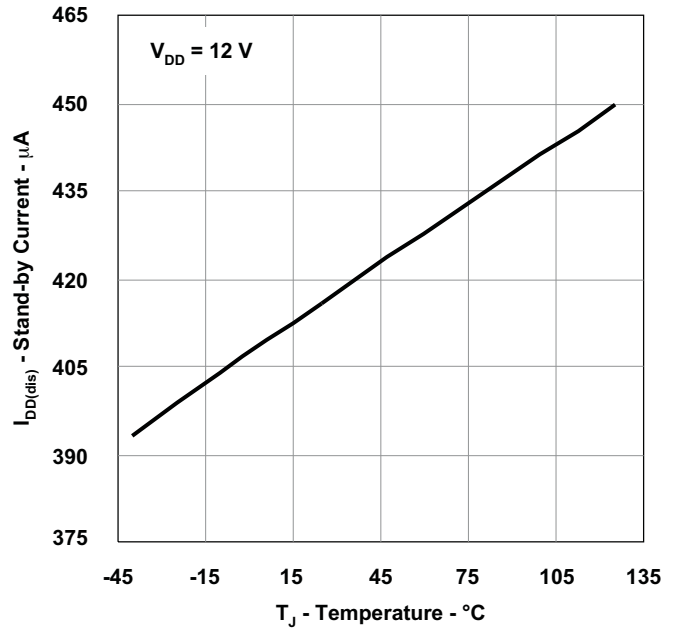

Figure 21.

UVLO THRESHOLDS
vs
TEMPERATURE

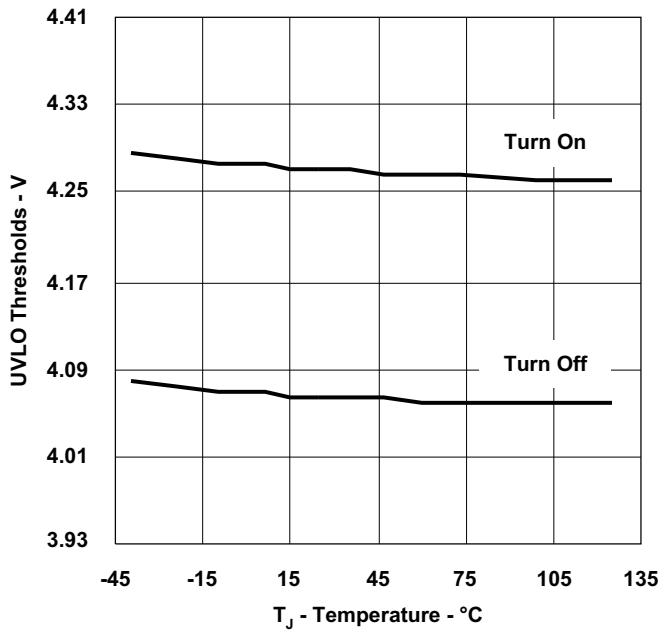

Figure 22.

UVLO VOLTAGE LOCKOUT HYSTERESIS
vs
TEMPERATURE

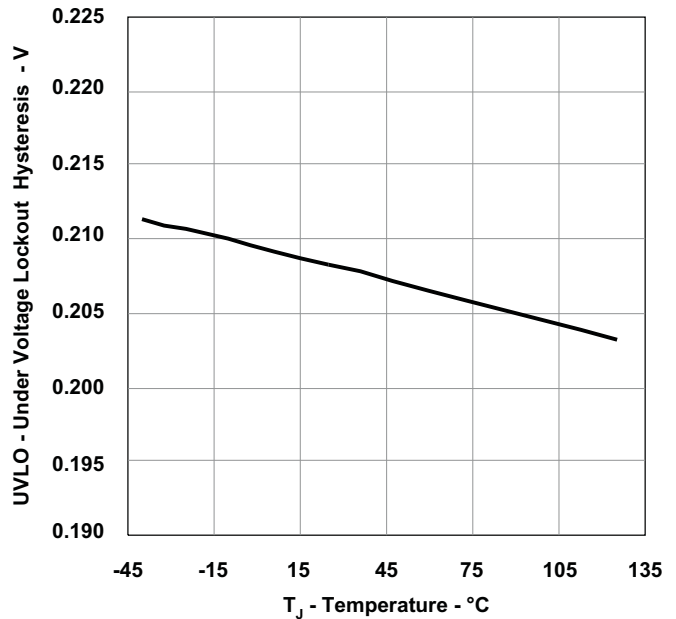

Figure 23.

TYPICAL CHARACTERISTICS (continued)

OPERATING SUPPLY CURRENT
vs
TEMPERATURE

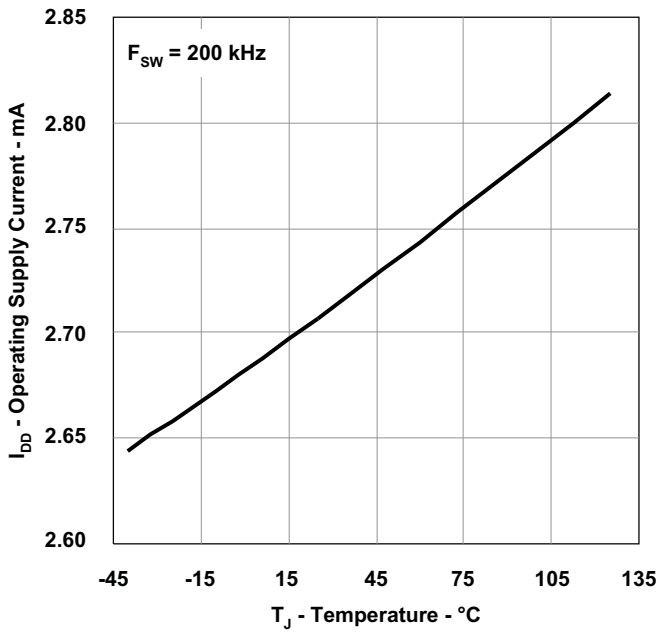

Figure 24.

SOFT-START CURRENT
vs
TEMPERATURE

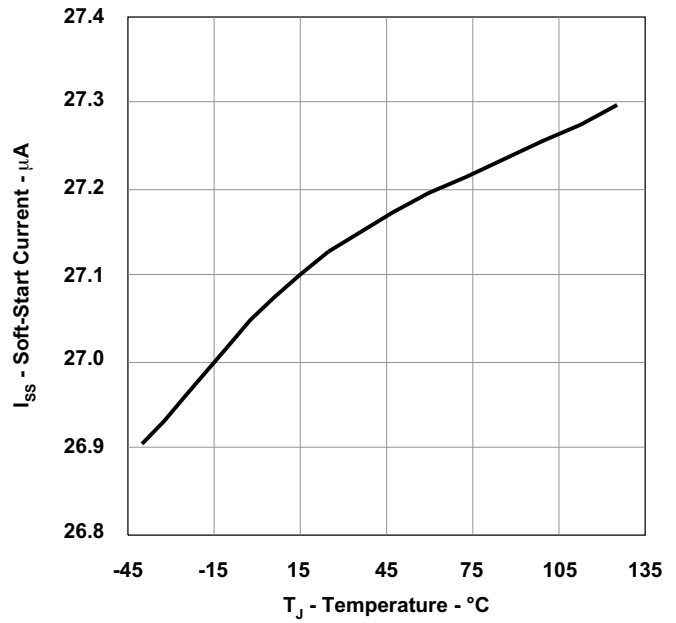

Figure 25.

CYCLE-BY-CYCLE CURRENT LIMIT
vs
TEMPERATURE

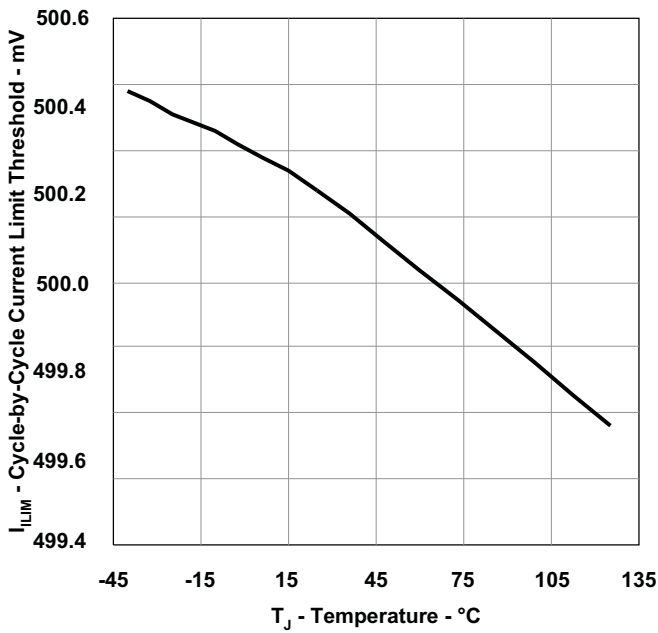

Figure 26.

RAMP/CS CLAMP VOLTAGE AND HICCUP PULL-UP THRESHOLD
vs
TEMPERATURE

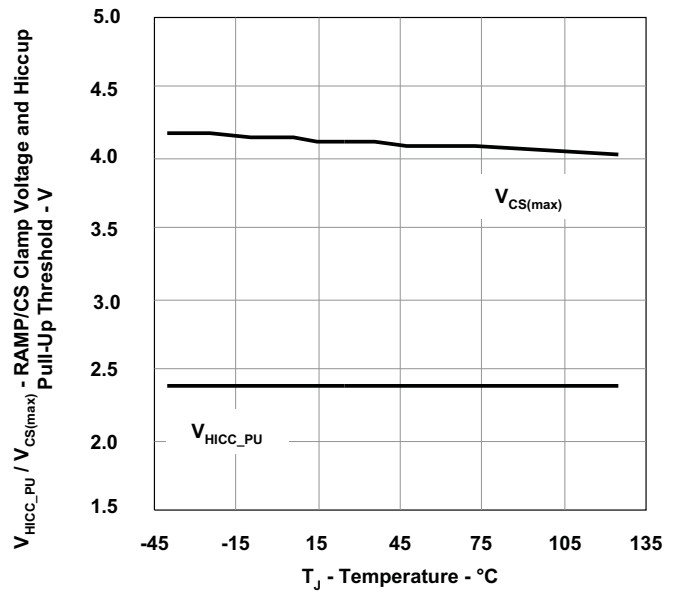

Figure 27.

TYPICAL CHARACTERISTICS (continued)

PROPAGATION DELAY/LEADING EDGE BLANKING
VS
TEMPERATURE

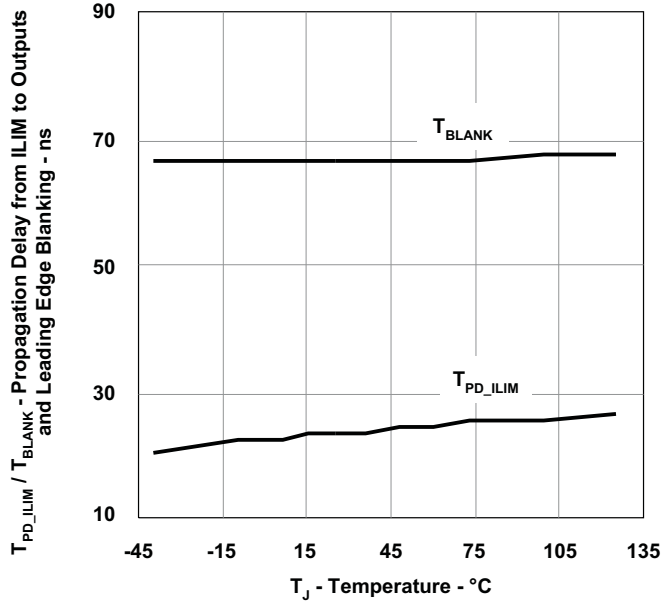

Figure 28.

CURRENT LIMIT SHUTDOWN DELAY TIMER AND HICCUP
RESTART
VS
TEMPERATURE

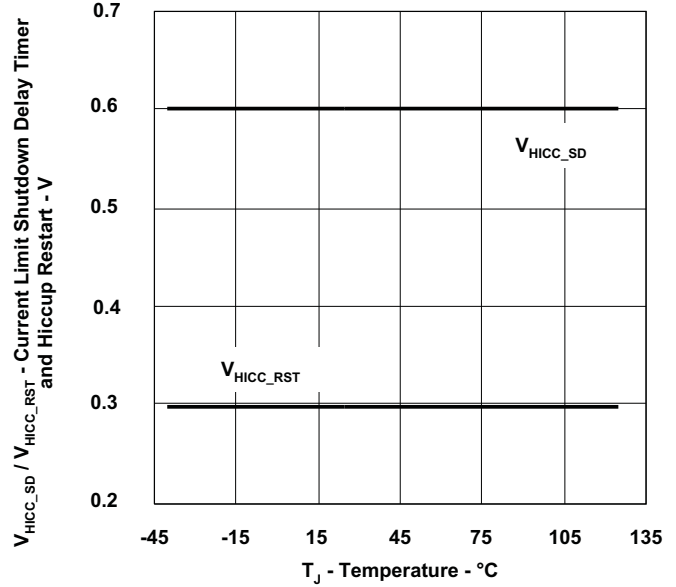

Figure 29.

REFERENCE VOLTAGE
VS
TEMPERATURE

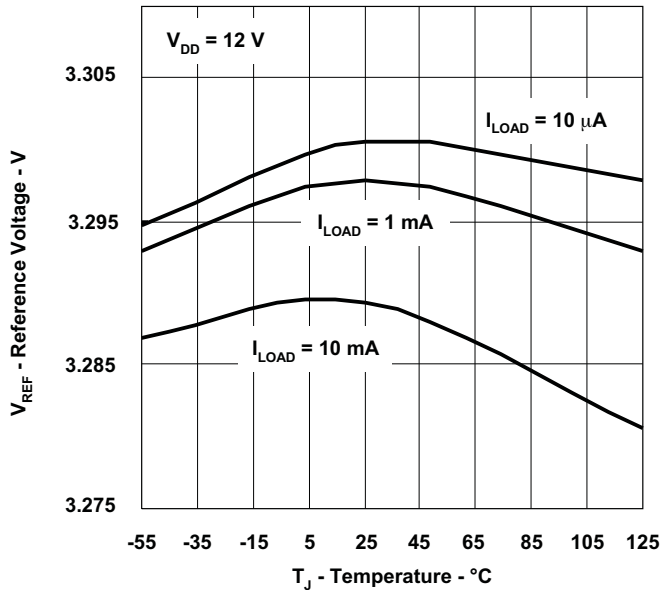

Figure 30.

REFERENCE VOLTAGE
VS
TEMPERATURE

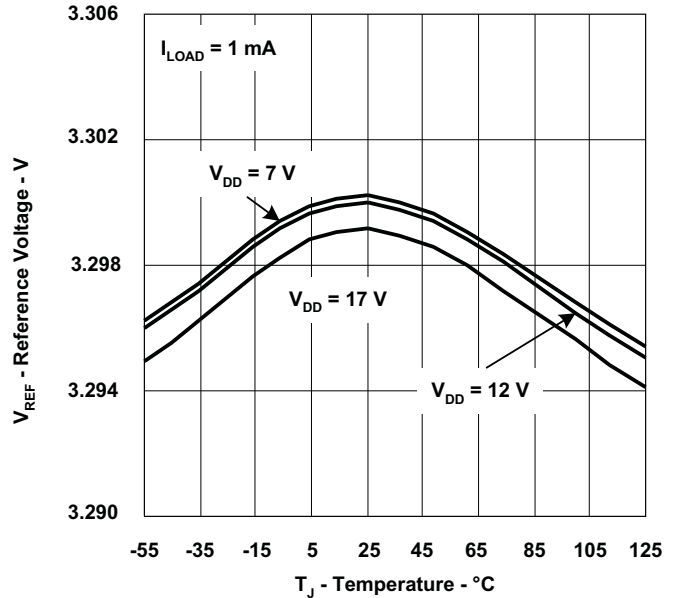

Figure 31.

TYPICAL CHARACTERISTICS (continued)

OVP INTERNAL REFERENCE
vs
TEMPERATURE

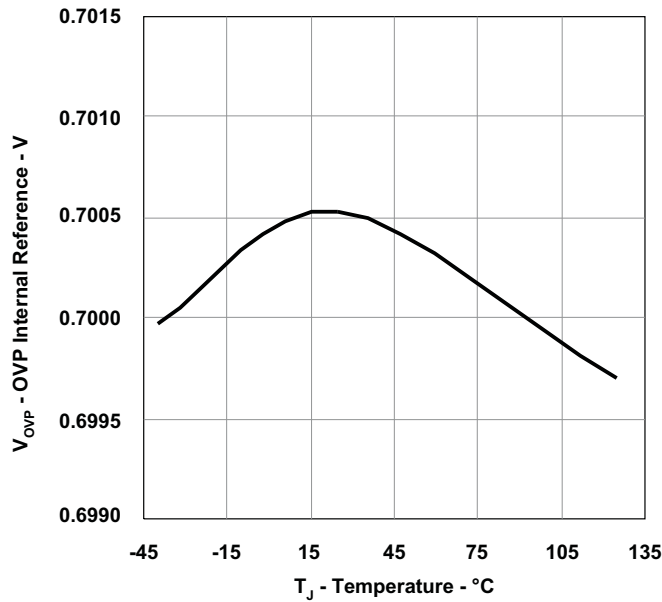

Figure 32.

OVP INTERNAL CURRENT
vs
TEMPERATURE

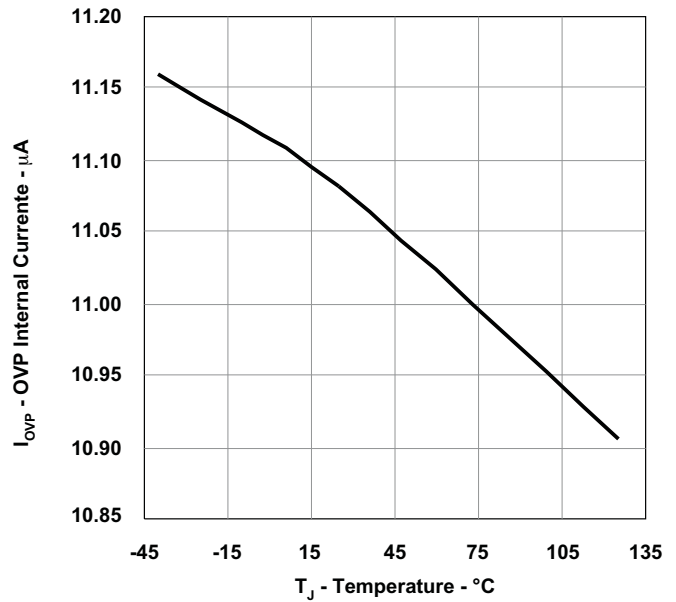

Figure 33.

MINIMUM SYNCHRONIZATION FREQUENCY
vs
TEMPERATURE

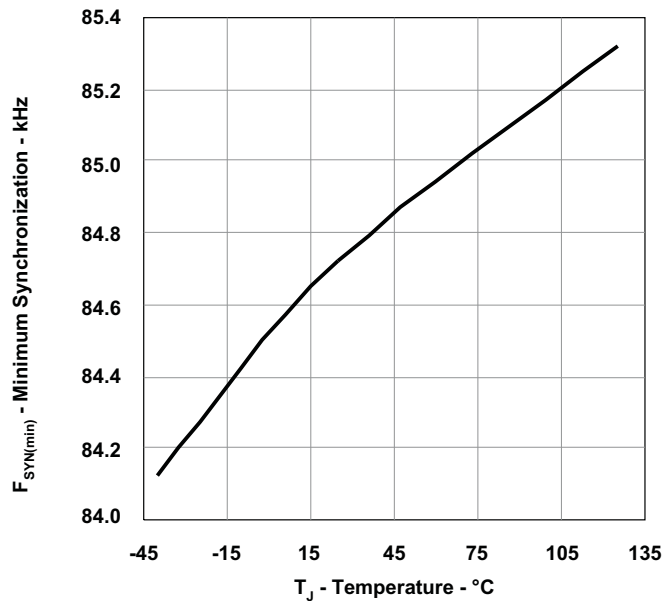

Figure 34.

MAXIMUM SYNCHRONIZATION FREQUENCY
vs
TEMPERATURE

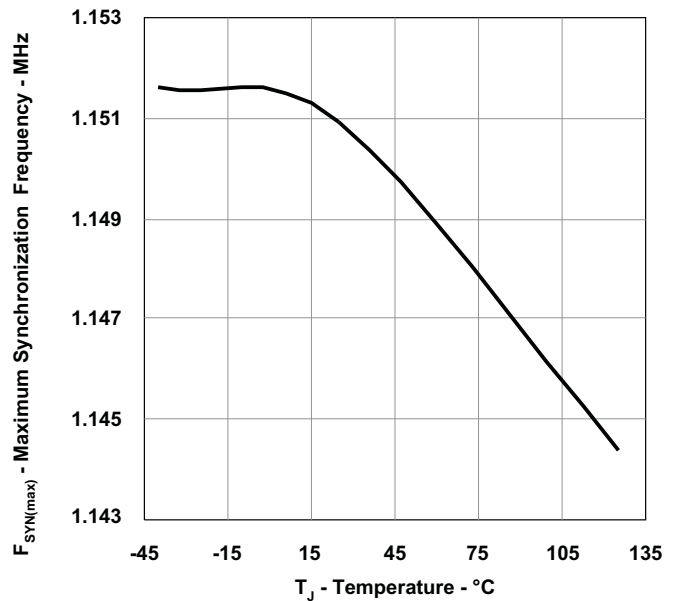

Figure 35.

TYPICAL CHARACTERISTICS (continued)

NOMINAL SWITCHING FREQUENCY
vs
TEMPERATURE

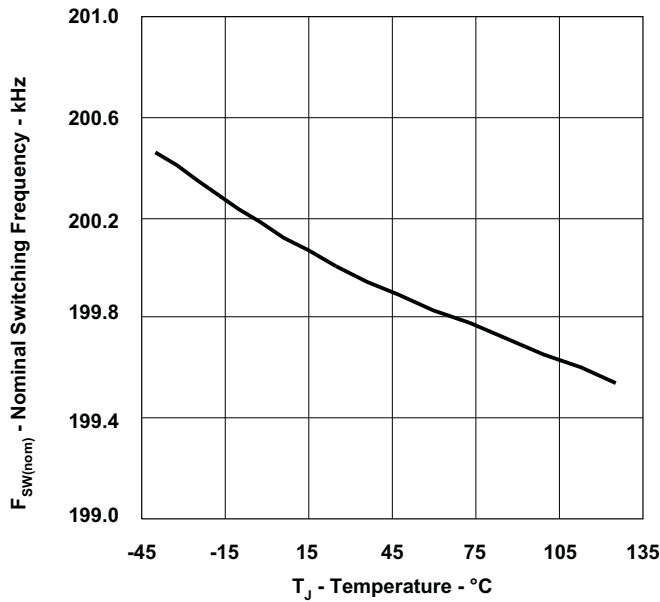

Figure 36.

DEAD TIME
vs
TEMPERATURE

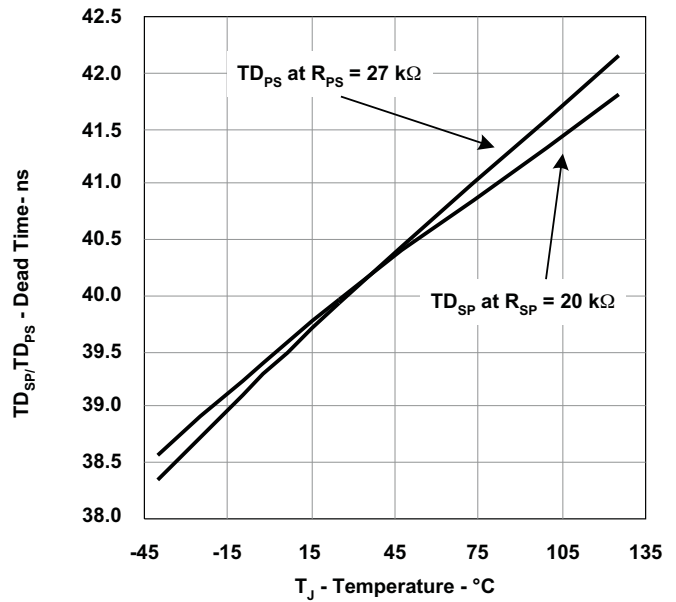

Figure 37.

OUTPUT RISE/FALL TIME
vs
TEMPERATURE

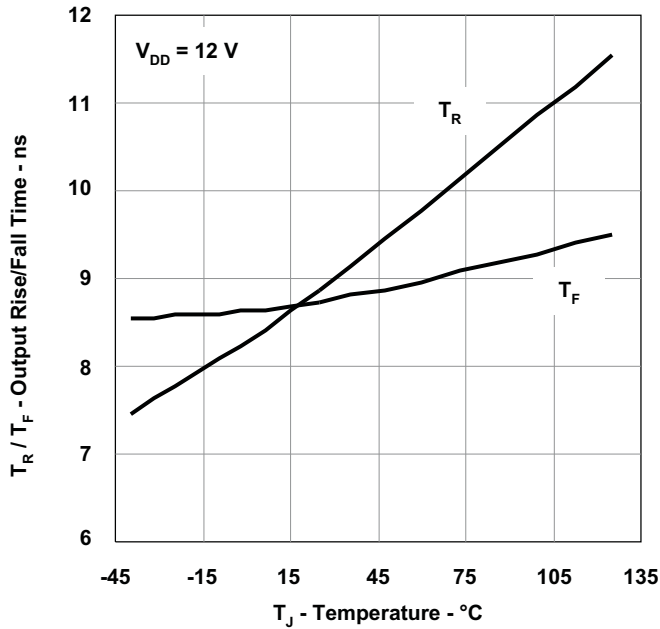

Figure 38.

OUTPUT SOURCE RESISTANCE/SINK RESISTANCE
vs
TEMPERATURE

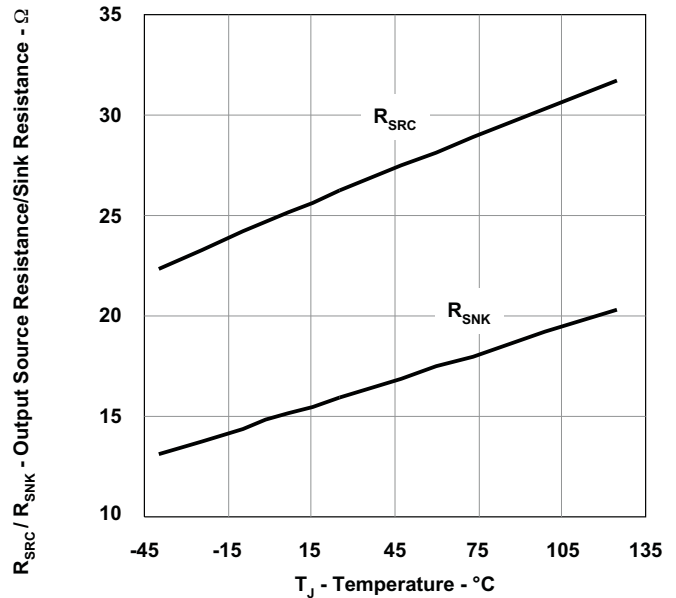

Figure 39.

APPLICATION INFORMATION

The UCC28250 is a high performance PWM controller with advanced synchronous rectifier outputs and is ideally suited for regulated half-bridge, full-bridge and push-pull converters. A dedicated internal pre-biased start up control loop working in conjunction with a primary-side voltage loop achieves monotonic pre-biased start up for either primary-side or secondary-side control applications. The UCC28250 architecture allows either voltage mode or current mode control.

Input voltage feedforward can be implemented, allowing PWM ramp generator to improve the converter line transient response. Advanced cycle-by-cycle current limit achieves volt-second balancing even during fault conditions. The hiccup timer helps the system to stay within a safe operation range under over load conditions. With a multifunction OVP/OTP pin, combinations of input voltage protection, output voltage protection and over temperature protection can be implemented. The UCC28250 allows individual programming of dead time between primary-side switch and secondary-side SRs, in order to allow optimal power stage design. Dead time can also be reduced to zero, and this allows optimal system configuration considering the delays on the gate driver stage. The UCC28250 also provides complete system level protection functions, including UVLO, thermal shut down and over voltage, over current protection.

Error Amplifier and PWM Generation

The UCC28250 includes a high performance internal error amplifier with low input offset, high source/sink current capability and high gain bandwidth (typical 3.5 MHz). The reference of the error amplifier (REF/EA+ pin) is set externally to support flexible trimming of the voltage loop, and to make the controller flexible for both primary side, as well as secondary-side control. The extra positive input for the error amplifier is the SS pin which is used to externally program the soft-start time of the converter's output.

During steady state operation, the primary switch duty cycle, D , is generated based on the external ramp on RAMP/CS pin and the COMP pin voltage. A higher COMP pin voltage results in a larger duty cycle. The secondary-side SR duty cycle is $SR_D = (1-D)$, complementary to the primary-side duty cycle, without considering the dead time between primary-side switch and secondary-side SR. The primary outputs begin to switch when COMP pin voltage is above the 350 mV internal offset. The synchronous rectifier outputs only switch after COMP pin voltage is above 550 mV internal offset. According to the internal logic, the minimum pulse width for the primary-side OUTA and OUTB is typically 100 ns.

During soft start, the primary-side switch duty cycle is generated based on the external ramp on RAMP/CS pin and the COMP pin voltage. However, the duty cycle of secondary-side SR is generated based on an internal ramp and the COMP pin voltage. When the converter is controlled on the primary side, an internal ramp is a fixed ramp with 3-V peak voltage. When the converter is controlled on secondary side, an internal ramp is generated based on the internal pre-biased start-up loop. An internal pre-biased start-up loop modifies the SR duty cycle during soft start to achieve the optimal pre-biased start-up performance.

After the SS pin reaches 2.9 V, the pre-biased start-up control loop is disabled. The secondary-side SR instantaneously changes into its steady state value as complementary to the primary-side duty cycle.

Pre-Biased Start Up

With the internal error amplifier, UCC28250 supports both primary-side control and secondary-side control. For different control methods, the controller is configured accordingly and so is the pre-biased start-up control. During soft start, both the primary-side switches' duty cycle and secondary-side SRs' duty cycle are increased. This gradually increases the output voltage until steady state operation is reached, thereby reducing surge current.

Secondary-Side Control

For secondary-side control, the UCC28250 implements close-loop control of both the primary-side switches and secondary-side synchronous rectifiers' duty cycles. This makes it easy to achieve optimal start up performance.

The internal error amplifier is set up as the control loop error amplifier. Connect REF/EA+, FB/EA-, COMP and VSENSE as shown in Figure 40. To achieve optimal pre-biased start up performance, the output voltage needs to be directly measured. The UCC28250 uses the VSENSE pin to directly sense this output voltage. Choose the voltage dividers on VSENSE slightly different to the FB/EA- voltage divider so that the voltage on VSENSE pin is roughly 10% to 15% more than FB/EA- pin voltages. Select R_{O1} equal to R_{S1} , and R_{S2} about 10% to 15% smaller than R_{O2} .

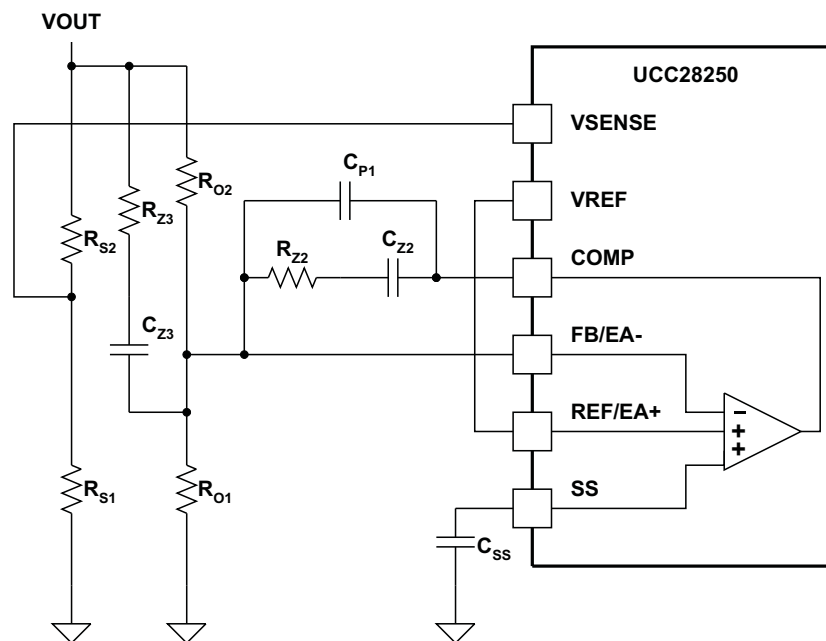

Figure 40. Error Amplifier Set Up for Secondary-Side Control

The error amplifier uses the lower voltage between the SS pin and the REF/EA+ pin to be the reference voltage for the feedback loop. In this method, the control loop is said to be 'closed' during the entire start up process, as it is always based on the true output voltage.

During soft start, the primary-side switch duty cycle is controlled by the COMP pin voltage and ramp voltage generated on the RAMP/CS pin. A higher COMP pin voltage results in larger duty cycle. However, to improve start up performance, the secondary-side synchronous rectifier duty cycle is controlled by a separate, internal ramp signal (generated by a dedicated pre-biased start up loop) and by the COMP pin voltage. This dedicated pre-biased loop is much faster than the regular voltage loop in order to avoid interaction between the two loops. The start up loop reads the output voltage via a transconductance error amplifier connected to the VSENSE pin. When the output voltage is higher than the reference, the pre-biased start up loop increases the SR duty cycle to reduce the output voltage. Conversely, when the output voltage is lower than the reference, the SR duty cycle is decreased to help maintain higher output voltage. To speed up the start up time, the minimum duty cycle of the synchronous rectifier is 50%.

Once the soft start is finished, the pre-biased loop is disabled and the duty cycle of the synchronous rectifiers becomes the complimentary of primary switches' duty cycle, with some dead time inserted in between.

Primary-Side Control

When the UCC28250 is sitting on the primary side, the internal error amplifier is connected as a voltage follower and an extra error amplifier is needed on the secondary side for closed loop control. The error amplifier implementation is shown in Figure 41.

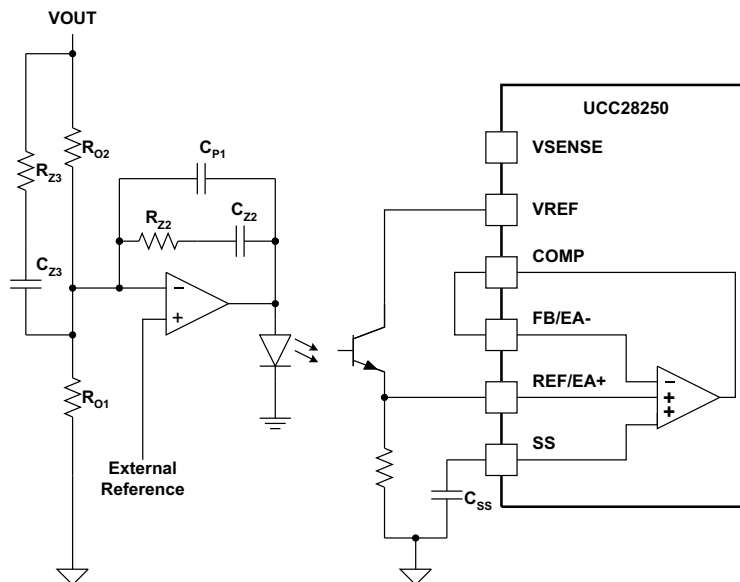

Figure 41. Error Amplifier Setup for Primary-Side Control

In the above configuration, the UCC28250 can only see the control loop feedback voltage, and cannot directly access the output voltage. The design of the soft-start time is critical to achieve optimal pre-biased start up performance. Some trial and error approaches are needed to achieve optimal performance. It is also important to choose the appropriate ramp amplitude. Refer to the ramp section discussion on the detailed design procedure for choosing ramp generation components.

During soft start, regardless of the pre-biased condition, the output voltage is always lower than the regulation voltage, so that the feedback loop is always saturated. When the internal error amplifier is connected as a voltage follower, the COMP voltage follows the lower of the voltage on the REF/EA+ pin and the SS pin. Since the feedback loop is saturated, the COMP pin always follows the SS pin voltage, until the output voltage becomes regulated and the feedback voltage takes over. In this control method, the output voltage control loop is always saturated, and the controller soft starts the COMP pin voltage. Therefore, it is called open loop soft start.

The primary-side switch duty cycle is controlled by the COMP pin voltage and by the RAMP/CS pin voltage. During soft start, the COMP pin voltage follows the SS pin as it is rising, so the primary-side switch duty cycle keeps increasing. When the output voltage becomes regulated, the feedback voltage becomes less than the SS pin voltage and the primary-side switch comes controlled by the control loop.

For the primary-side control setup, because output voltage is not directly accessible, the internal pre-biased start up loop is disabled by connecting VSENSE to VREF. Instead, the internal ramp used to generate the synchronous rectifier duty cycle is fixed, with the peak voltage of 3 V. The duty cycle of the synchronous rectifier increases as the SS pin voltage increases. When the SS pin voltage reaches 2.9 V, the soft start is considered finished and the synchronous rectifier duty cycle becomes the complementary of the primary-side switch duty cycle, minus the programmed dead time. Because of different COMP pin voltages at different line voltages, the SR duty cycle generated by the internal ramp might be different than the complementary of the primary-side switch duty cycle (1-D). If the duty cycle is too large, the internal logic is able to limit the duty cycle to (1-D). However, if the duty cycle is too small, when the soft start is finished, the SR duty cycle has a sudden change, which will cause output voltage disturbance. To optimize the pre-biased start up performance, it is recommended that the duty cycle change at the end of soft start be as small as possible.

Voltage Mode Control and Input Voltage Feed-Forward

For voltage mode control, a resistor R_{CS} and a capacitor C_{CS} are connected externally at RAMP/CS pin as shown in Figure 42. A ramp signal is generated on the RAMP/CS pin, at a rate of two times that of the switching frequency. The generated ramp signal is used to control the duty cycle for both the primary-side switches and secondary-side synchronous rectifiers. The ramp amplitude can be fixed or variable with the input voltage (input voltage feedforward).

To realize a fixed amplitude ramp, connect R_{CS} to the VREF pin, so that the ramp capacitor charging voltage is fixed regardless of line and load condition. The RAMP/CS pin is clamped internally to 4 V for internal device protection. Because the internal pull-down switch has about 40- Ω on-resistance, the C_{CS} value must be small enough to discharge RAMP/CS from the peak to ground within $T_{D(sp)} + 70$ ns (i.e. the pulse width of BLANK signal).

To achieve the input voltage feedforward, the slope of the ramp needs to be proportional to the input voltage. Tie R_{CS} to the input line voltage. Because the ramp voltage is much lower than the input voltage, the ramp capacitor charging current is considered to be proportional to the input voltage. With input voltage feedforward, the COMP pin voltage should only move slightly even with large input voltage variation. This will provide much better line transient response for the converter.

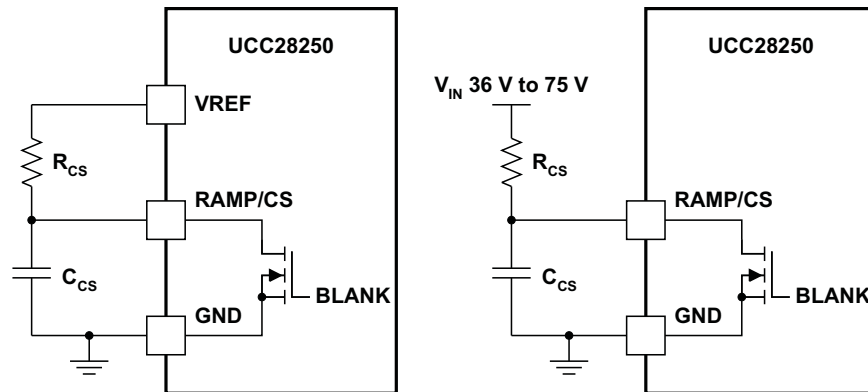

Figure 42. External Configuration of RAMP/CS Pin With/Without Feed-Forward Operation

The input voltage feedforward also helps on pre-biased start up. When doing primary-side control to pre-biased start up, three conditions need to be considered:

Condition 1

At initial start up the primary side needs to provide enough energy to prevent output voltage dip;

Condition 2

At the end of soft start, it is required to keep the SR duty cycle change to be as small as possible. With input voltage feedforward, the COMP pin voltage is virtually fixed for different input voltages. Therefore, before the end of soft start, the duty cycle is the same for different input voltages. Choose the R_{CS} and C_{CS} following the procedure below.

Considering initial start up, the RAMP peak voltage should be:

$$V_{RAMP} = \frac{V_{IN} - V_{PRE-BIAS}}{2 \times n} \times V_{SR(ramp)} \quad (23)$$

In this equation, V_{IN} is the input voltage because of the feedforward any input voltage should be fine; $V_{PRE-BIAS}$ is the highest pre-bias start-up voltage required by the system; n is the transformer primary to secondary turns ratio and $V_{SR(ramp)}$ is the internal SR ramp peak voltage 3 V.

Another consideration is at the end of soft start, the SR duty cycle changes from controlled by the soft start, to complimentary to the primary-side duty cycle. The design should keep the transition as smooth as possible. Considering this, based on the output voltage and input voltage range, as well as the transformer turns ratio, calculate the SR duty cycle at different line voltages.

Next, based on the maximum duty cycle on the SR_D_{MAX} , and the internal fixed ramp amplitude 3 V, the COMP voltage at regulation can be chosen as:

$$V_{COMP(final)} = (SR_D_{MAX} - 0.5) \times 3V \times 2 \quad (24)$$

Condition 3

Use the calculated COMP pin voltage to derive the external ramp amplitude

$$V_{RAMP} = \frac{V_{COMP(final)}}{(1 - SR_D_{MAX}) \times 2} \quad (25)$$

According to the calculated ramp voltage from [Equation 23](#) and [Equation 25](#) some trade off is required to pick up the appropriate ramp voltage. Based on the selected ramp capacitor C_{CS} value, choose the ramp resistor R_{CS} value:

$$R_{CS} = \frac{V_{IN(max)} \times 2}{V_{RAMP} \times C_{CS} \times f_{sw}} \quad (26)$$

In this equation, $V_{IN(max)}$ is the maximum input voltage, f_{sw} is the switching frequency.

Because these calculations ignore the dead time and the non-linearity of the ramp, slight modification is expected to achieve the optimal design. When the input voltage feed forward is not used, refer to the RAMP pin discussion for RC calculation.

Peak Current Mode Control

For peak current mode control, RAMP/CS pin is connected directly with the current signal generated from a current transformer. The current signal must be compatible with the input range of the COMP pin. External slope compensation is required to prevent sub-harmonic oscillation and to maintain flux-balance. The slope compensation can be implemented by using OUTA and OUTB to charge external capacitors and use the voltage follower to add into the sensed current signal, as shown in Figure 43. Follow the peak current mode control theory to select compensation slope or refer to “Modeling, Analysis and Compensation of the Current-Mode Converter”, (TI Literature Number SLUA101).

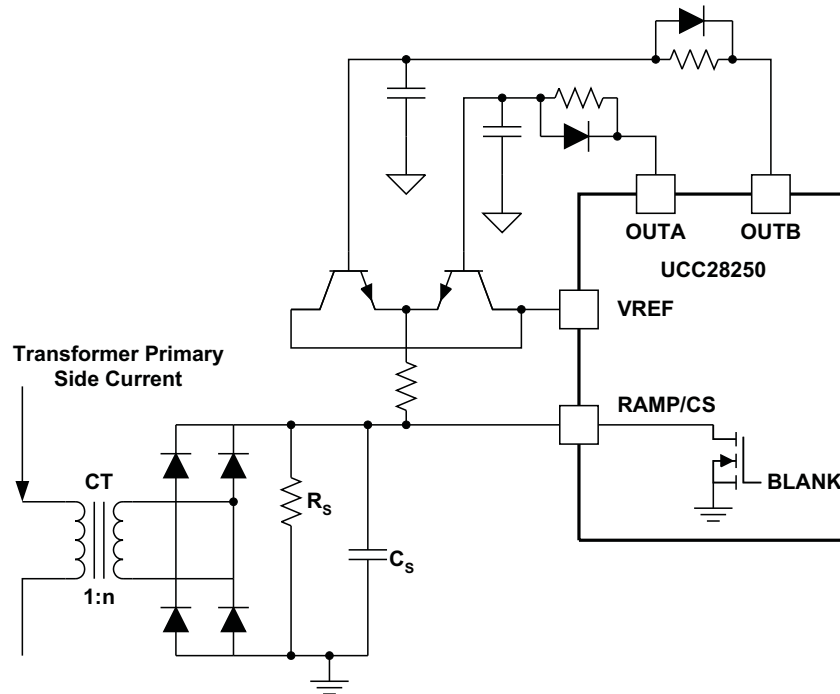

Figure 43. UCC28250 Set Up for Peak Current Mode Control

Cycle-by-Cycle Current Limit and Hiccup Mode Protection

Cycle-by-cycle current limit is accomplished using the ILIM pin for both current mode control and voltage mode control. The input to the ILIM pin represents the primary current information. If the voltage sensed at ILIM pin exceeds 0.5 V, the current sense comparator terminates the pulse of output OUTA or OUTB. If the high current condition persists, the controller operates in a cycle-by-cycle current limit mode with duty cycle determined by the current sense comparator. ILIM pin is pulled down by an internal switch at the rising edge of each clock cycle. This internal switch remains on for an additional 70 ns after OUTA or OUTB goes high to blank leading edge transient noise in the current sensing loop. This reduces the filtering requirements at the ILIM pin and improves the current sense response time.

UCC28250 makes it possible to maintain flux balance during cycle-by-cycle current limit operation. The duty cycles of primary switches are always matched. If one switch duty cycle is terminated earlier because of current limiting, a matched duty cycle is applied to the other switch for the next half switching cycle, regardless of the current condition, as shown in Figure 44. This matched duty cycle helps to maintain volt-second balancing on the transformer and prevents the transformer saturation.

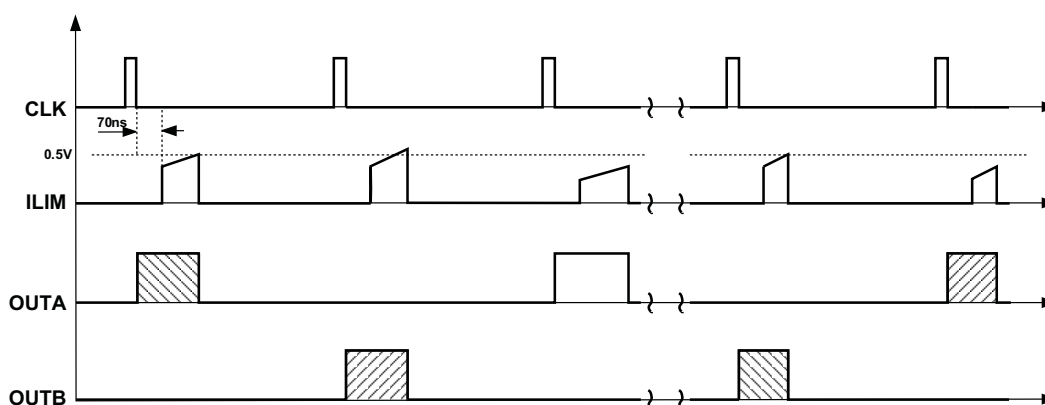

Figure 44. Cycle-by-Cycle Current Limit Duty Cycle Matching

Once the current limit is triggered, the 75- μ A internal current source begins to charge the capacitor on HICC pin. If the current limit condition went away before HICC pin reaches 0.6 V, the device stops charge HICC capacitor and begins to discharge it with 2.7- μ A current source. If the cycle-by-cycle current limit condition continues, HICC pin reaches 0.6 V, and all four outputs are shut down. The UCC28250 then enters hiccup mode. During hiccup mode, all four outputs keep low; SS pin is pulled to ground internally; a 2.7- μ A current source continuously discharge HICC pin capacitor; until HICC pin voltage reaches 0.3 V. After that, HICC pin is discharged internally to get ready for the next HICC event. The whole converter starts with soft start after hiccup mode.

The cycle-by-cycle current limit operation time before all four outputs shut down is programmed by external capacitor C_{HICC} at HICC pin. The delay time can be calculated as:

$$T_{OC(\text{delay})} = C_{HICC} \times \frac{0.6V}{75\mu A} \quad (27)$$

The hiccup timer keeps all outputs being zero until the timer expires. The hiccup time T_{HICC} is calculated as:

$$T_{HICC} = C_{HICC} \times \frac{2.4V - 0.3V}{2.7\mu A} \quad (28)$$

As soon as the outputs are shut-down, SS pin is pulled down internally until the hiccup restart timer is reset after time duration T_{HICC} . The detailed illustration of HICCUP mode is shown in [Figure 45](#).

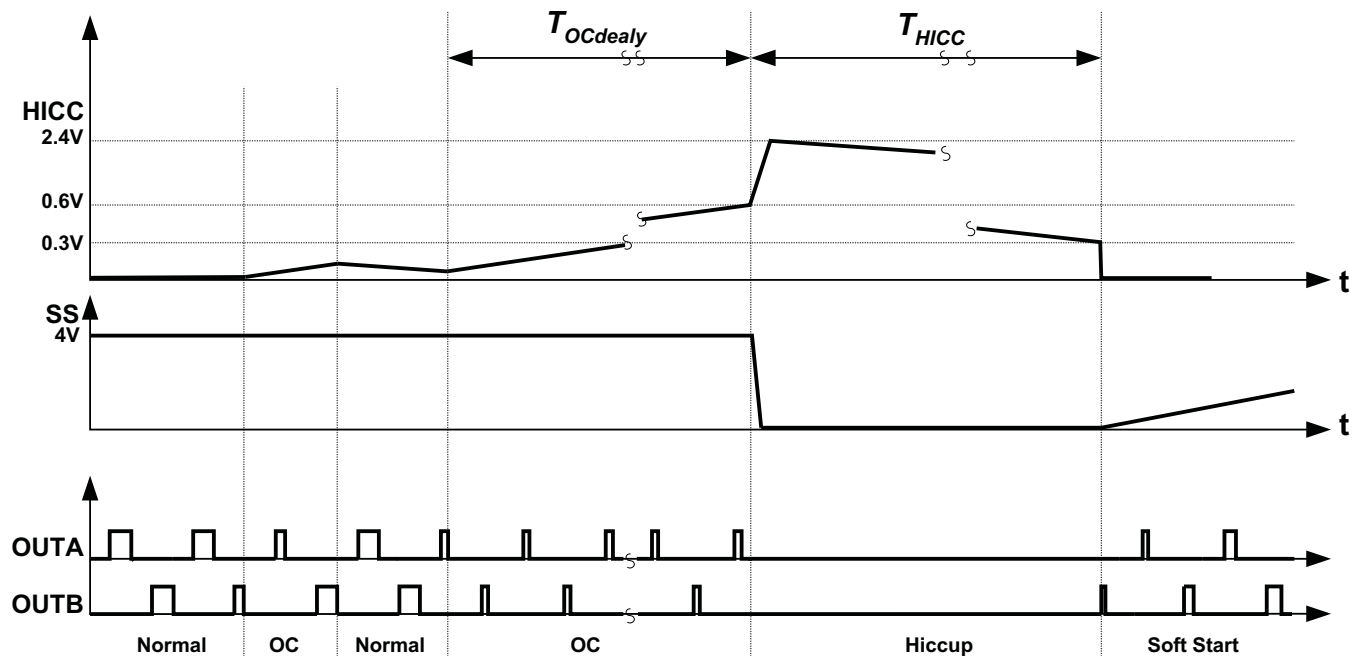

Figure 45. Cycle-by-Cycle Current Limit Delay Timer and Hiccup Restart Timer

Thermal Protection

Internal thermal shutdown circuitry protects the UCC28250 in the event the maximum rated junction temperature is exceeded. When activated, typically at 160°C, with the maximum threshold at 170°C and minimum threshold at 150°C the controller is forced into a low power standby mode. The outputs (OUTA, OUTB, SRA, SRB) are disabled. This helps to prevent accidental device overheating. A 20°C hysteresis is added to prevent comparator oscillation. During thermal shutdown, the UCC28250 follows a normal start up sequence after the junction temperature falls below 140°C (typical value, with 130°C minimum threshold and 150°C maximum threshold).

Design Example

The example provided here is to show how to design a symmetrical half bridge converter of voltage mode control with UCC28250 on primary side.

Figure 46 is the circuit diagram to be used in this design example. This design example is to show how to determine the values in the circuit associated to UCC28250 programming.

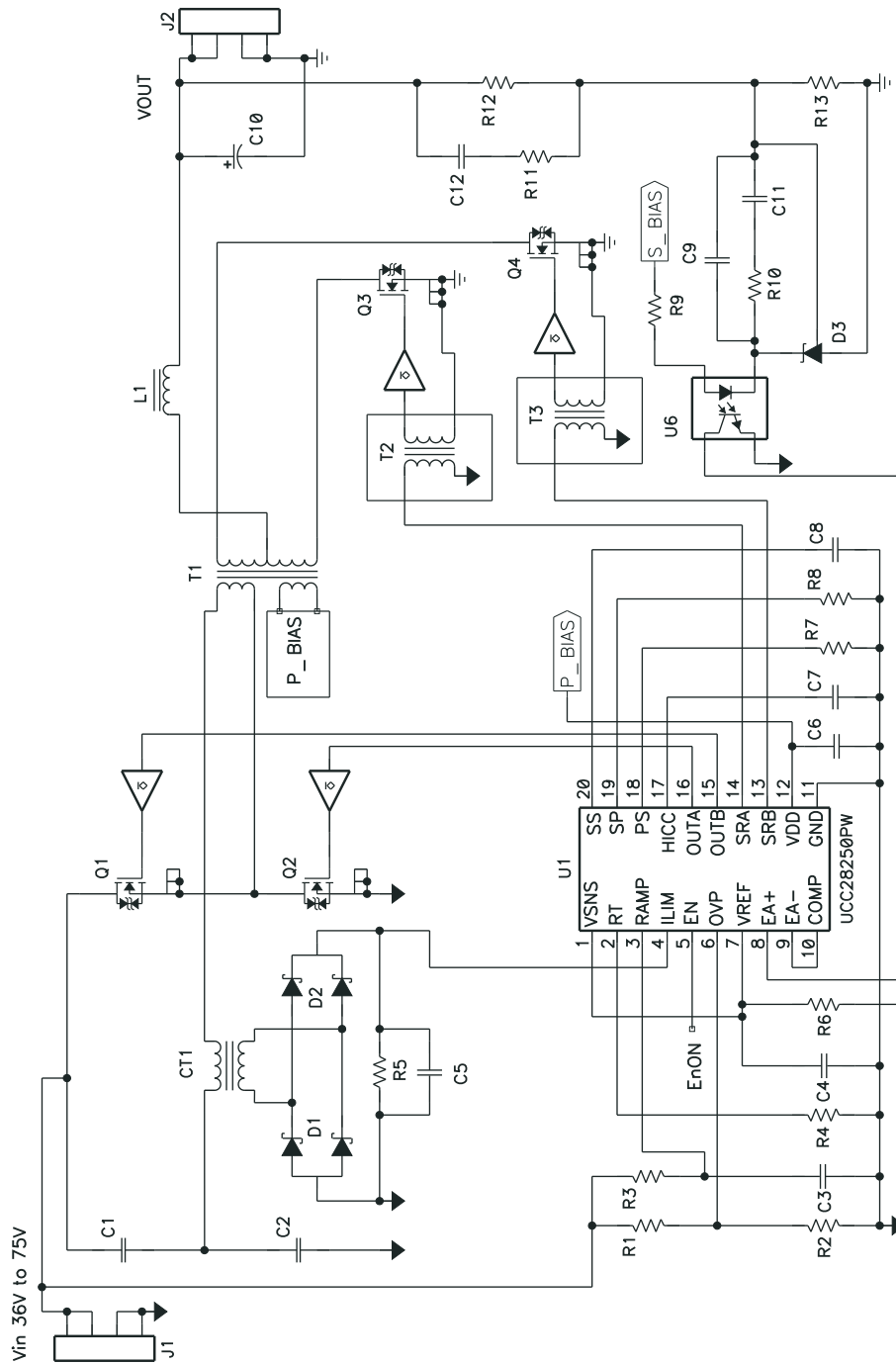

Figure 46. Circuit Diagram in Design Example.

Table 1 shows the specifications for the design example.

Design Steps

Step 1, Power Stage Design

The power stage design in this example is standard and the same as that for symmetrical half bridge converter of voltage mode control. From the standard design, these components are determined. This includes Q1 through Q4, C1, C2, CT1, D1 and D2, D3, T1, T2 and T3, and U6. Their design is standard. Also, design associated to current sensing and protection is also standard. This includes CT1, D1, D2, R5 and C5.

Step 2, Feedback Loop Design

D3 (TLV431) with U6, R6, R9, R10, R12, R13, C11 and C12 are composed of standard type 3 feedback loop compensation network and output voltage set point. Their design is also standard.

Table 1. Specifications for the Design Example

PARAMETER		MIN	TYP	MAX	UNITS
V _{IN}	Input voltage	36	48	72	VDC
V _{OUT}	Output voltage		3.3		
P _{OUT}	Output power			75	W
I _{OUT}	Output load current			23	A
C _{OUT}	Load capacitance			5000	μF
f _{SW}	Switching frequency		150		kHz
P _{LIMIT}	Over-power limit			150%	
η	Efficiency at full load		90%		
	Isolation	1500			V

Step 3, Programming the Device

Step 3-1

Equation 3 is used to determine RT based on switching frequency, 300 kHz and assumes the dead time of 150 ns.

$$R_T = \frac{\frac{1}{2 \times f_{sw}} - T_{d(SP)}}{33.2 \text{ pF}} = \frac{\frac{1}{2 \times 150 \text{ kHz}} - 150 \text{ ns}}{33.2 \text{ pF}} = 94.9 \text{ k}\Omega \Rightarrow R_4 = 100 \text{ k}\Omega \quad (29)$$

Step 3-2, Determine RAMP Resistance and Capacitance

There are two-fold considerations to determine RAMP resistance and capacitance. Equation 23 provides RAMP consideration for SR initial start up with prebias. The corresponding RAMP peak voltage is determined with input voltage low line and maximum prebias output voltage. In the below T1 turns ratio $n = 4$.

$$V_{RAMP} = \frac{V_{IN} - V_{pre-bias}}{2 \times n} \times V_{SR_RAMP} = \frac{36 \text{ V} - 3.0 \text{ V}}{2 \times 4} \times 3.0 \text{ V} = 0.750 \text{ V} \quad (30)$$

Equation 24 and Equation 25 provides RAMP consideration for soft start completion to make duty cycle match $(1-D) = SR_D$.

1. Calculate OUTA or OUTB duty cycle at 75-V input voltage, 3.3-V output.

$$D = \frac{n \times V_o}{V_{IN}} \times \frac{1}{2} = \frac{4 \times 3.3 \text{ V}}{75 \text{ V}/2} \times \frac{1}{2} = 0.176 \quad (31)$$

2. Calculate SRA or SRB duty cycle.

$$SR_D = 1 - D = 1 - 0.176 = 0.82 \quad (32)$$

3. Calculate the COMP voltage value in steady state (Equation 24).

$$V_{COMP} = (SR_D - 0.5) \times 3.0 \text{ V} \times 2 = (0.824 - 0.5) \times 3.0 \text{ V} \times 2 = 1.944 \text{ V} \quad (33)$$

4. Calculate the RAMP peak value (Equation 25).

$$V_{RAMP} = \frac{V_{COMP}}{(D \times 2)} = \frac{1.944 \text{ V}}{(0.176 \times 2)} = 5.523 \text{ V} \quad (34)$$

5. Arbitrary select C_{RAMP} 470 pF, then $C_3 = 470 \text{ pF}$.

6. Calculate R_{RAMP} .

$$R_{RAMP_1} = \frac{1}{2 \times \ln\left(\frac{V_{CHARGE}}{V_{CHARGE} - V_{RAMP}}\right) \times C_{RAMP} \times f_{sw}} = \frac{1}{2 \times \ln\left(\frac{36 \text{ V}}{36 \text{ V} - 0.750 \text{ V}}\right) \times 470 \text{ pF} \times 150 \text{ kHz}} = 336.9 \text{ k}\Omega \quad (35)$$

$$R_{RAMP_2} = \frac{1}{2 \times \ln\left(\frac{V_{CHARGE}}{V_{CHARGE} - V_{RAMP}}\right) \times C_{RAMP} \times f_{sw}} = \frac{1}{2 \times \ln\left(\frac{75 \text{ V}}{75 \text{ V} - 5.523 \text{ V}}\right) \times 470 \text{ pF} \times 150 \text{ kHz}} = 92.7 \text{ k}\Omega \quad (36)$$

As different RAMP resistor values are obtained, at this stage, we may take their average value for initial design.

Step 3-3, Determine Soft-Start Capacitance

Determine soft-start capacitance with soft-start time 15 ms.

$$C_{SS} = \frac{27 \mu\text{A} \times T_{SS}}{V_{\text{COMP}(\text{final})}} = \frac{27 \mu\text{A} \times 15 \text{ms}}{4.0 \text{V}} = 0.101 \mu\text{F} \Rightarrow C8 = 0.1 \mu\text{F} \quad (37)$$

Step 3-4, Determine Dead-Time Resistance

Assuming the dead time is 150 ns, Select R7 = R8 = 121 kΩ based on [Figure 9](#) and [Figure 10](#).

Step 3-5, Determine OCP Hiccup Off-Time Capacitance

Assuming off time is 0.8 s ([Equation 15](#)).

$$C_{\text{HICC}} = T_{\text{HICC}} \times \frac{2.7 \mu\text{A}}{2.4 \text{V} - 0.3 \text{V}} = 0.8 \text{s} \times \frac{2.7 \mu\text{A}}{2.4 \text{V} - 0.3 \text{V}} = 1.03 \mu\text{F} \Rightarrow C7 = 1.0 \mu\text{F} \quad (38)$$

Step 3-6, Determine Primary-Side OVP Resistance

Assuming OV_OFF = 73 V, OV_ON = 72 V ([Equation 16](#) to [Equation 18](#)).

$$R_2 \leq \frac{0.7 \text{V} \times (V_r - V_f)}{11 \mu\text{A} \times (V_r - 0.7 \text{V})} = \frac{0.7 \text{V} \times (73 \text{V} - 72 \text{V})}{11 \mu\text{A} \times (73 \text{V} - 0.7 \text{V})} = 880 \Omega \Rightarrow R2 = 866 \Omega \quad (39)$$

$$R_1 = \frac{V_R - 0.7 \text{V}}{0.7 \text{V}} \times R_2 = \frac{73 \text{V} - 0.7 \text{V}}{0.7 \text{V}} \times 866 \Omega = 89.4 \text{k}\Omega \Rightarrow R1 = 88.7 \text{k}\Omega \quad (40)$$

$$R_3 = \frac{0.7 \text{V} \times (V_R - V_F) - 11 \mu\text{A} \times R_2 \times (V_R - 0.7 \text{V})}{11 \mu\text{A} \times V_r} = \frac{0.7 \text{V} \times (73 \text{V} - 72 \text{V}) - 11 \mu\text{A} \times 866 \Omega \times (73 \text{V} - 0.7 \text{V})}{11 \mu\text{A} \times 73 \text{V}} = 14 \Omega \Rightarrow R14 = 14 \Omega \quad (41)$$

Step 3-7, Select Capacitance for VDD and VREF

As recommended by the datasheet, select C6 = C4 = 1.0 μF. The final design is shown in [Figure 47](#).

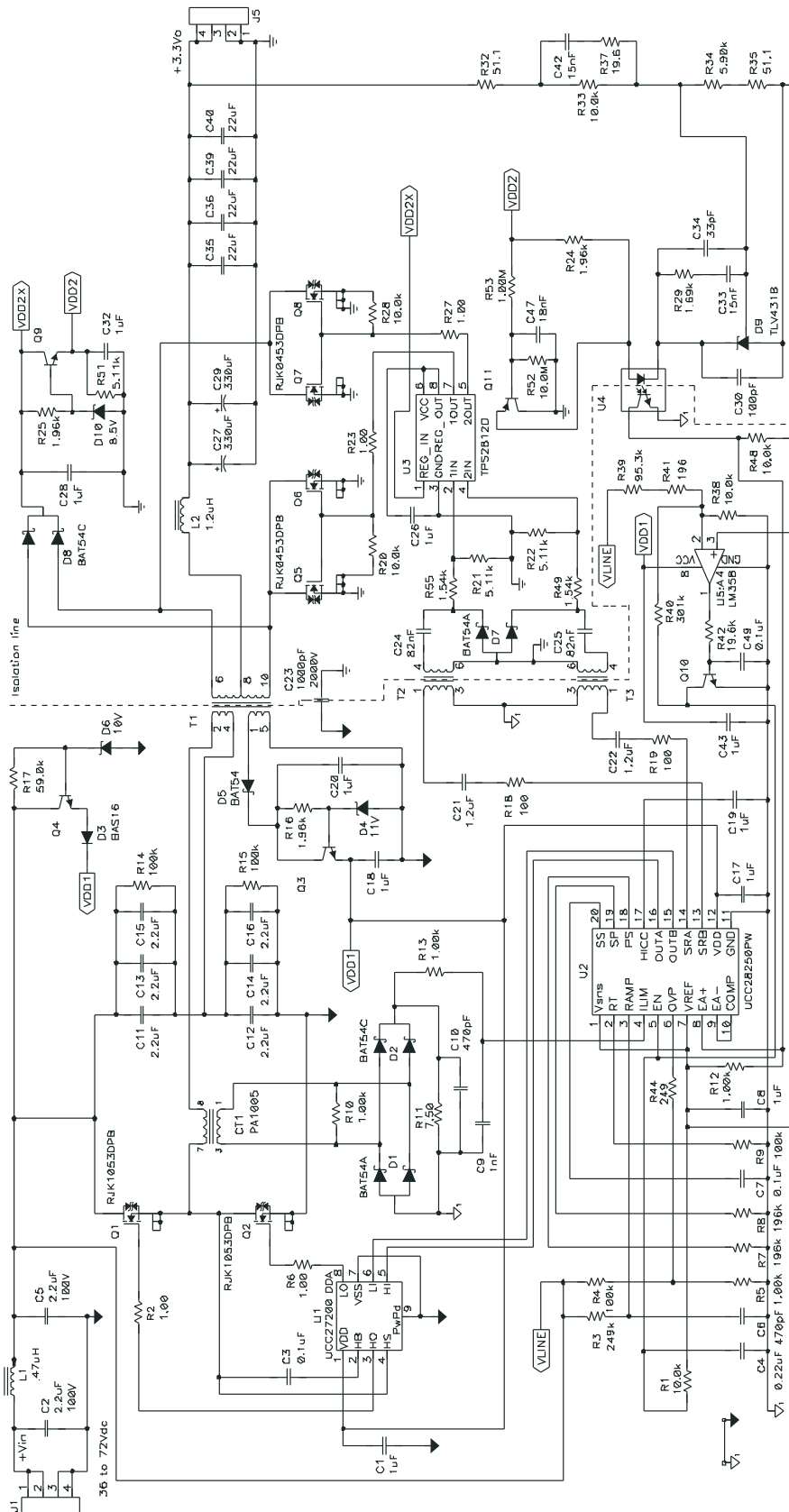

Figure 47. Schematics of Primary-Side Control Design Example

PACKAGING INFORMATION

Orderable Device	Status ⁽¹⁾	Package Type	Package Drawing	Pins	Package Qty	Eco Plan ⁽²⁾	Lead/Ball Finish	MSL Peak Temp ⁽³⁾
UCC28250PW	PREVIEW	TSSOP	PW	20	70	TBD	Call TI	Call TI
UCC28250PWR	PREVIEW	TSSOP	PW	20	2000	TBD	Call TI	Call TI
UCC28250RGPR	PREVIEW	QFN	RGP	20	3000	TBD	Call TI	Call TI
UCC28250RGPT	PREVIEW	QFN	RGP	20	250	TBD	Call TI	Call TI

⁽¹⁾ The marketing status values are defined as follows:

ACTIVE: Product device recommended for new designs.

LIFEBUY: TI has announced that the device will be discontinued, and a lifetime-buy period is in effect.

NRND: Not recommended for new designs. Device is in production to support existing customers, but TI does not recommend using this part in a new design.

PREVIEW: Device has been announced but is not in production. Samples may or may not be available.

OBSOLETE: TI has discontinued the production of the device.

⁽²⁾ Eco Plan - The planned eco-friendly classification: Pb-Free (RoHS), Pb-Free (RoHS Exempt), or Green (RoHS & no Sb/Br) - please check <http://www.ti.com/productcontent> for the latest availability information and additional product content details.

TBD: The Pb-Free/Green conversion plan has not been defined.

Pb-Free (RoHS): TI's terms "Lead-Free" or "Pb-Free" mean semiconductor products that are compatible with the current RoHS requirements for all 6 substances, including the requirement that lead not exceed 0.1% by weight in homogeneous materials. Where designed to be soldered at high temperatures, TI Pb-Free products are suitable for use in specified lead-free processes.

Pb-Free (RoHS Exempt): This component has a RoHS exemption for either 1) lead-based flip-chip solder bumps used between the die and package, or 2) lead-based die adhesive used between the die and leadframe. The component is otherwise considered Pb-Free (RoHS compatible) as defined above.

Green (RoHS & no Sb/Br): TI defines "Green" to mean Pb-Free (RoHS compatible), and free of Bromine (Br) and Antimony (Sb) based flame retardants (Br or Sb do not exceed 0.1% by weight in homogeneous material)

⁽³⁾ MSL, Peak Temp. -- The Moisture Sensitivity Level rating according to the JEDEC industry standard classifications, and peak solder temperature.

Important Information and Disclaimer:The information provided on this page represents TI's knowledge and belief as of the date that it is provided. TI bases its knowledge and belief on information provided by third parties, and makes no representation or warranty as to the accuracy of such information. Efforts are underway to better integrate information from third parties. TI has taken and continues to take reasonable steps to provide representative and accurate information but may not have conducted destructive testing or chemical analysis on incoming materials and chemicals. TI and TI suppliers consider certain information to be proprietary, and thus CAS numbers and other limited information may not be available for release.

In no event shall TI's liability arising out of such information exceed the total purchase price of the TI part(s) at issue in this document sold by TI to Customer on an annual basis.

RGP (S-PQFP-N20)

PLASTIC QUAD FLATPACK

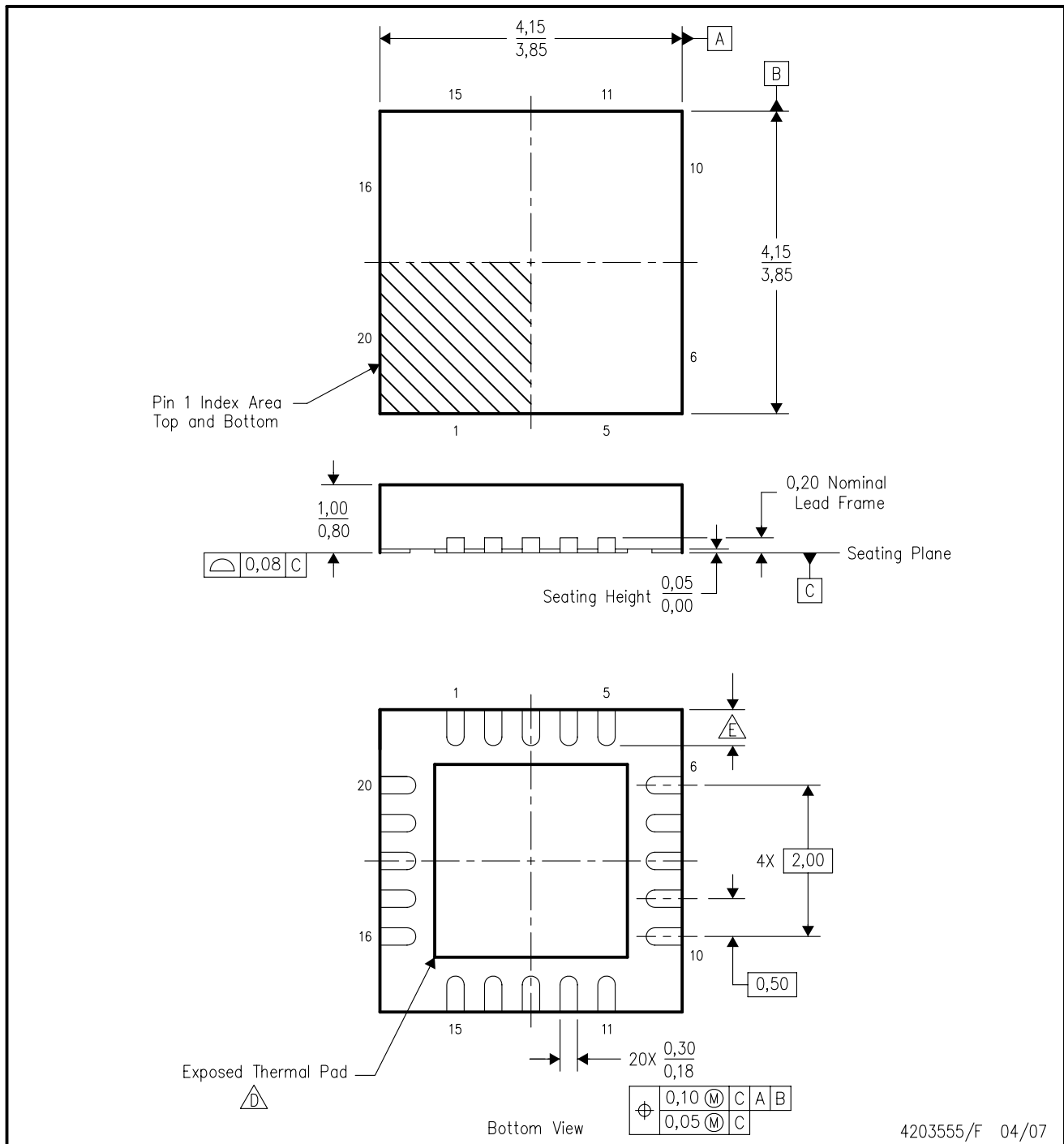

4203555/F 04/07

- NOTES:
- A. All linear dimensions are in millimeters. Dimensioning and tolerancing per ASME Y14.5M-1994.
 - B. This drawing is subject to change without notice.
 - C. QFN (Quad Flatpack No-Lead) package configuration.
 - $\triangle D$ The package thermal pad must be soldered to the board for thermal and mechanical performance. See the Product Data Sheet for details regarding the exposed thermal pad dimensions.
 - $\triangle E$ Check thermal pad mechanical drawing in the product datasheet for nominal lead length dimensions.

THERMAL PAD MECHANICAL DATA

RGP (S-PVQFN-N20)

PLASTIC QUAD FLATPACK NO-LEAD

THERMAL INFORMATION

This package incorporates an exposed thermal pad that is designed to be attached directly to an external heatsink. The thermal pad must be soldered directly to the printed circuit board (PCB). After soldering, the PCB can be used as a heatsink. In addition, through the use of thermal vias, the thermal pad can be attached directly to the appropriate copper plane shown in the electrical schematic for the device, or alternatively, can be attached to a special heatsink structure designed into the PCB. This design optimizes the heat transfer from the integrated circuit (IC).

For information on the Quad Flatpack No-Lead (QFN) package and its advantages, refer to Application Report, QFN/SON PCB Attachment, Texas Instruments Literature No. SLUA271. This document is available at www.ti.com.

The exposed thermal pad dimensions for this package are shown in the following illustration.

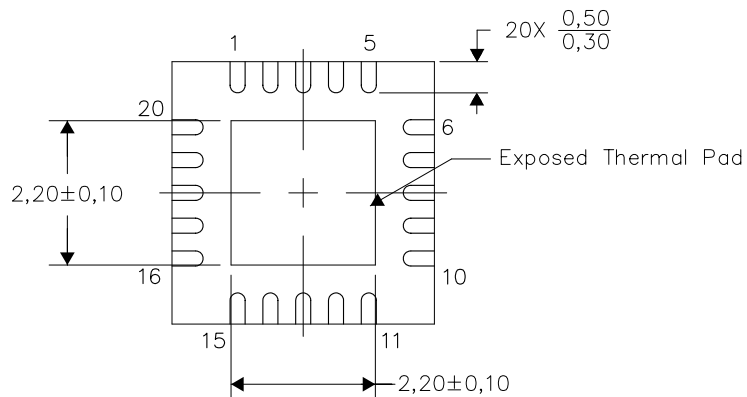

Bottom View

NOTE: All linear dimensions are in millimeters

Exposed Thermal Pad Dimensions

4206346-4/S 03/10

RGP (S-PVQFN-N20)

PLASTIC QUAD FLATPACK NO-LEAD

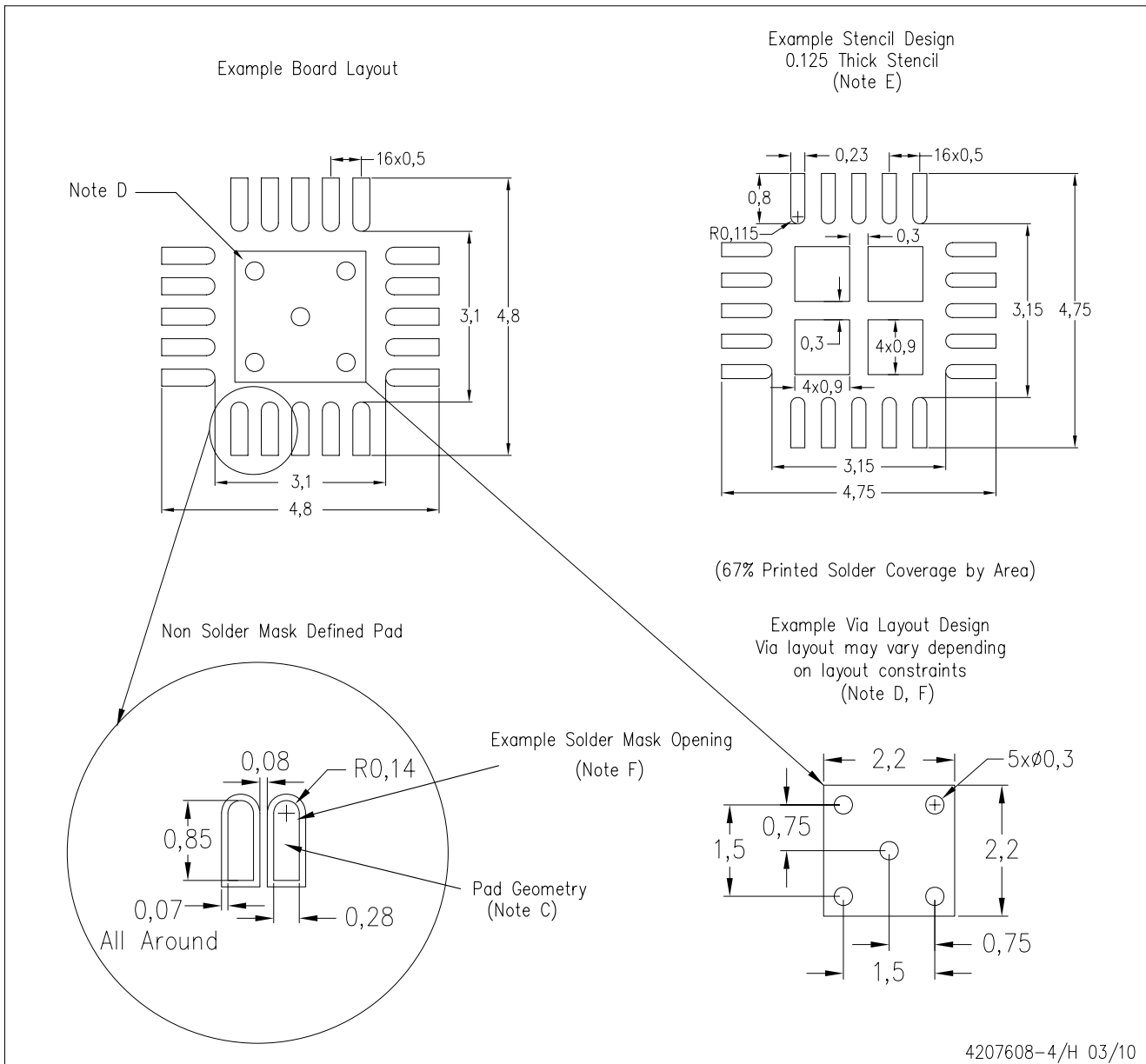

- NOTES:
- All linear dimensions are in millimeters.
 - This drawing is subject to change without notice.
 - Publication IPC-7351 is recommended for alternate designs.
 - This package is designed to be soldered to a thermal pad on the board. Refer to Application Note, Quad Flat-Pack Packages, Texas Instruments Literature No. SLUA271, and also the Product Data Sheets for specific thermal information, via requirements, and recommended board layout. These documents are available at www.ti.com <<http://www.ti.com>>.
 - Laser cutting apertures with trapezoidal walls and also rounding corners will offer better paste release. Customers should contact their board assembly site for stencil design recommendations. Refer to IPC 7525 for stencil design considerations.
 - Customers should contact their board fabrication site for recommended solder mask tolerances and via tenting recommendations for vias placed in the thermal pad.

PW (R-PDSO-G**)

PLASTIC SMALL-OUTLINE PACKAGE

14 PINS SHOWN

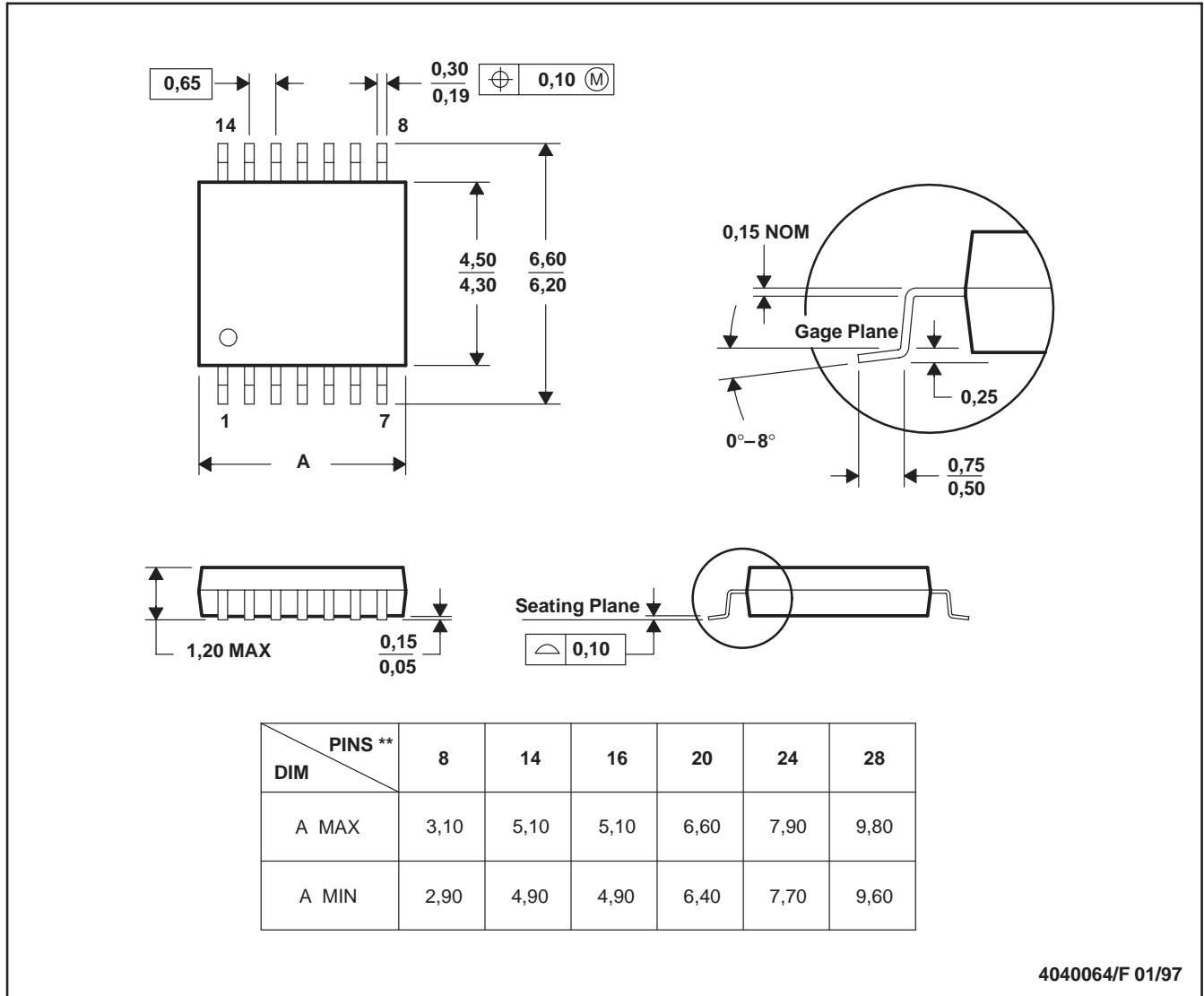

- NOTES: A. All linear dimensions are in millimeters.
 B. This drawing is subject to change without notice.
 C. Body dimensions do not include mold flash or protrusion not to exceed 0,15.
 D. Falls within JEDEC MO-153

IMPORTANT NOTICE

Texas Instruments Incorporated and its subsidiaries (TI) reserve the right to make corrections, modifications, enhancements, improvements, and other changes to its products and services at any time and to discontinue any product or service without notice. Customers should obtain the latest relevant information before placing orders and should verify that such information is current and complete. All products are sold subject to TI's terms and conditions of sale supplied at the time of order acknowledgment.

TI warrants performance of its hardware products to the specifications applicable at the time of sale in accordance with TI's standard warranty. Testing and other quality control techniques are used to the extent TI deems necessary to support this warranty. Except where mandated by government requirements, testing of all parameters of each product is not necessarily performed.

TI assumes no liability for applications assistance or customer product design. Customers are responsible for their products and applications using TI components. To minimize the risks associated with customer products and applications, customers should provide adequate design and operating safeguards.

TI does not warrant or represent that any license, either express or implied, is granted under any TI patent right, copyright, mask work right, or other TI intellectual property right relating to any combination, machine, or process in which TI products or services are used. Information published by TI regarding third-party products or services does not constitute a license from TI to use such products or services or a warranty or endorsement thereof. Use of such information may require a license from a third party under the patents or other intellectual property of the third party, or a license from TI under the patents or other intellectual property of TI.

Reproduction of TI information in TI data books or data sheets is permissible only if reproduction is without alteration and is accompanied by all associated warranties, conditions, limitations, and notices. Reproduction of this information with alteration is an unfair and deceptive business practice. TI is not responsible or liable for such altered documentation. Information of third parties may be subject to additional restrictions.

Resale of TI products or services with statements different from or beyond the parameters stated by TI for that product or service voids all express and any implied warranties for the associated TI product or service and is an unfair and deceptive business practice. TI is not responsible or liable for any such statements.

TI products are not authorized for use in safety-critical applications (such as life support) where a failure of the TI product would reasonably be expected to cause severe personal injury or death, unless officers of the parties have executed an agreement specifically governing such use. Buyers represent that they have all necessary expertise in the safety and regulatory ramifications of their applications, and acknowledge and agree that they are solely responsible for all legal, regulatory and safety-related requirements concerning their products and any use of TI products in such safety-critical applications, notwithstanding any applications-related information or support that may be provided by TI. Further, Buyers must fully indemnify TI and its representatives against any damages arising out of the use of TI products in such safety-critical applications.

TI products are neither designed nor intended for use in military/aerospace applications or environments unless the TI products are specifically designated by TI as military-grade or "enhanced plastic." Only products designated by TI as military-grade meet military specifications. Buyers acknowledge and agree that any such use of TI products which TI has not designated as military-grade is solely at the Buyer's risk, and that they are solely responsible for compliance with all legal and regulatory requirements in connection with such use.

TI products are neither designed nor intended for use in automotive applications or environments unless the specific TI products are designated by TI as compliant with ISO/TS 16949 requirements. Buyers acknowledge and agree that, if they use any non-designated products in automotive applications, TI will not be responsible for any failure to meet such requirements.

Following are URLs where you can obtain information on other Texas Instruments products and application solutions:

Products		Applications	
Amplifiers	amplifier.ti.com	Audio	www.ti.com/audio
Data Converters	dataconverter.ti.com	Automotive	www.ti.com/automotive
DLP® Products	www.dlp.com	Communications and Telecom	www.ti.com/communications
DSP	dsp.ti.com	Computers and Peripherals	www.ti.com/computers
Clocks and Timers	www.ti.com/clocks	Consumer Electronics	www.ti.com/consumer-apps
Interface	interface.ti.com	Energy	www.ti.com/energy
Logic	logic.ti.com	Industrial	www.ti.com/industrial
Power Mgmt	power.ti.com	Medical	www.ti.com/medical
Microcontrollers	microcontroller.ti.com	Security	www.ti.com/security
RFID	www.ti-rfid.com	Space, Avionics & Defense	www.ti.com/space-avionics-defense
RF/IF and ZigBee® Solutions	www.ti.com/lprf	Video and Imaging	www.ti.com/video
		Wireless	www.ti.com/wireless-apps

Mailing Address: Texas Instruments, Post Office Box 655303, Dallas, Texas 75265
Copyright © 2010, Texas Instruments Incorporated

www.BDTIC.com/TI