

MICROPROCESSOR SUPERVISOR WITH WATCHDOG TIMER

FEATURES

- Qualified for Automotive Applications
- Fully Programmable Reset Threshold
- Fully Programmable Reset Period
- Fully Programmable Watchdog Period
- 2% Accurate Reset Threshold
- Input Voltage Down to 2 V
- Input 18- μ A Maximum Input Current
- Reset Valid Down to 1 V

DESCRIPTION

The UCC2946 is designed to provide accurate microprocessor supervision, including reset and watchdog functions. During power up, the device asserts a reset signal \overline{RES} with VDD as low as 1 V. The reset signal remains asserted until the VDD voltage rises and remains above the reset threshold for the reset period. Both reset threshold and reset period are programmable by the user.

The UCC2946 is also resistant to glitches on the VDD line. Once \overline{RES} has been deasserted, any drops below the threshold voltage need to be of certain time duration and voltage magnitude to generate a reset signal. These values are shown in Figure 1. An I/O line of the microprocessor may be tied to the watchdog input (WDI) for watchdog functions. If the I/O line is not toggled within a set watchdog period, programmable by the user, WDO is asserted. The watchdog function is disabled during reset conditions.

The UCC2946 is available in 8-pin TSSOP (PW) package to optimize board space.

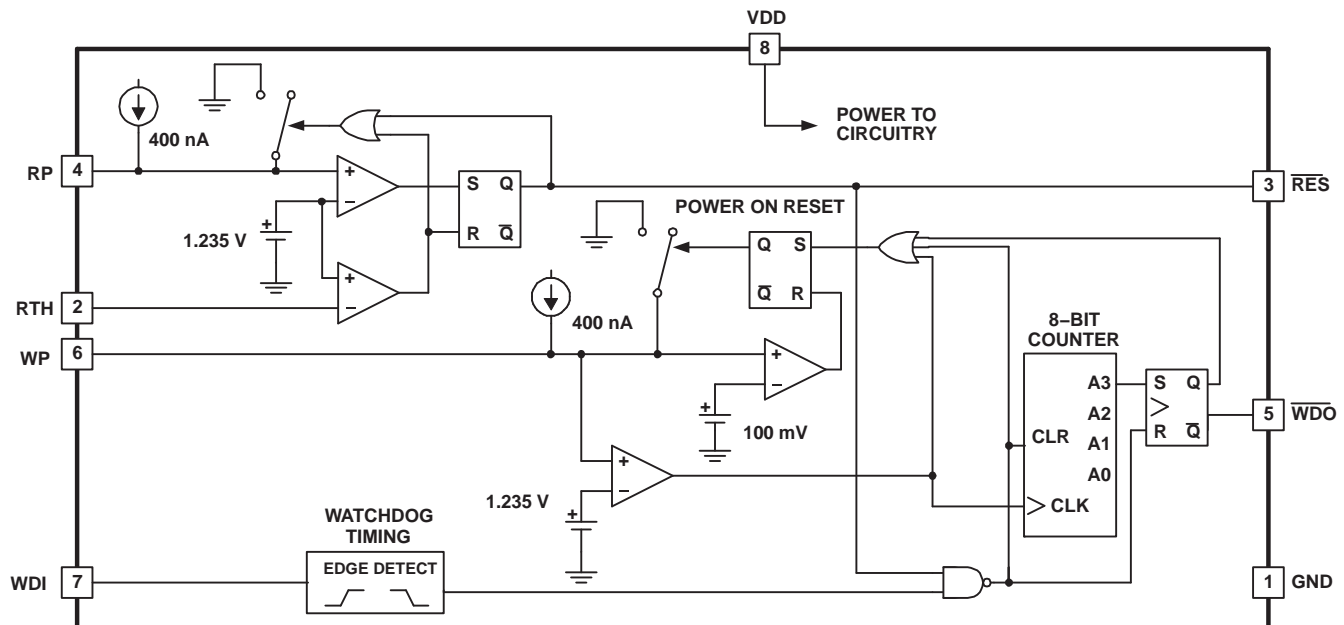

UDG–02192



Please be aware that an important notice concerning availability, standard warranty, and use in critical applications of Texas Instruments semiconductor products and disclaimers thereto appears at the end of this data sheet.



These devices have limited built-in ESD protection. The leads should be shorted together or the device placed in conductive foam during storage or handling to prevent electrostatic damage to the MOS gates.

ORDERING INFORMATION⁽¹⁾

T _A	PACKAGE ⁽²⁾		ORDERABLE PART NUMBER
–40°C to 105°C	TSSOP – PW	Reel of 3000	UCC2946TPWRQ1

- (1) For the most current package and ordering information, see the Package Option Addendum at the end of this document, or see the TI web site at www.ti.com.
- (2) Package drawings, thermal data, and symbolization are available at www.ti.com/packaging.

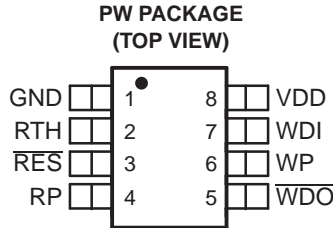

TERMINAL FUNCTIONS

TERMINAL		I/O	DESCRIPTION
NAME	NO.		
GND	1	—	Ground reference for the device
RES	3	O	This pin is high only if the voltage on the RTH has risen above 1.235 V. Once RTH rises above the threshold, this pin remains low for the reset period. This pin asserts low and remains low if the RTH voltage dips below 1.235 V for an amount of time determined by Figure 1 .
RTH	2	I	This input compares its voltage to an internal 1.25-V reference. By using external resistors, a user can program any desired reset threshold.
RP	4	I	This pin allows the user to program the reset period by adjusting an external capacitor.
VDD	8	I	Supply voltage for the device
WDI	7	I	This pin is the input to the watchdog timer. If this pin is not toggled or strobed within the watchdog period, WDO is asserted.
WDO	5	O	This pin is the watchdog output. This pin is asserted low if the WDI pin is not strobed or toggled within the watchdog period.
WP	6	I	This pin allows the user to program the watchdog period by adjusting an external capacitor.

ABSOLUTE MAXIMUM RATINGS⁽¹⁾

over operating free-air temperature range (unless otherwise noted)

		UCC2946
V _{IN}	Input voltage range	10 V
I _{OUT}	WDO output current	20 mA
T _J	Junction temperature range	–55°C to 150°C
T _{stg}	Storage temperature	–65°C to 150°C
	Lead temperature 1,6 mm (1/16 inch) from case for 10 seconds	300°C
	ESD rating, HBM	1500 V

- (1) Stresses beyond those listed under "absolute maximum ratings" may cause permanent damage to the device. These are stress ratings only, and functional operation of the device at these or any other conditions beyond those indicated under "recommended operating conditions" is not implied. Exposure to absolute-maximum-rated conditions for extended periods may affect device reliability. Voltages are with respect to GND. Currents are positive into, and negative out of the specified terminal.

ELECTRICAL CHARACTERISTICS

T_A = –40°C to 105°C, 2.1 V ≤ V_{DD} ≤ 5.5 V (unless otherwise noted)

PARAMETER	TEST CONDITIONS	MIN	TYP	MAX	UNIT	
Reference						
V _{DD}	Operating voltage	2.1		5.5	V	
I _{DD}	Supply current		12	18	μA	
V _{DD(min)}	Minimum operating voltage ⁽¹⁾			1.1	V	
Reset Section						
	Reset threshold voltage	V _{DD} rising	1.17	1.235	1.26	V
	Threshold hysteresis		15		mV	
I _{LEAK}	Input leakage current			5	nA	
V _{OH}	High-level output voltage	I _{SOURCE} = 2 mA	V _{DD} – 0.3		V	
V _{OL}	Low-level output voltage	I _{SINK} = 2 mA		0.1	V	
		I _{SINK} = 20 μA, V _{DD} = 1 V		0.4		
	VDD-to-output delay time	V _{DD} = –1 mV/μs	120		μs	
	Reset period	C _{RP} = 64 nF	140	200	320	ms
Watchdog Section						
V _{IH}	High-level input voltage, WDI		0.7 × V _{DD}		V	
V _{IL}	Low-level input voltage, WDI			0.3 × V _{DD}	V	
	Watchdog period	C _{RP} = 64 nF	0.96	1.60	2.56	s
	Watchdog pulse width		50		ns	
V _{OH}	High-level output voltage	I _{SOURCE} = 2 mA	V _{DD} – 0.3		V	
V _{OL}	Low-level output voltage	I _{SINK} = 2 mA		0.1	V	

- (1) Minimum supply voltage where $\overline{\text{RES}}$ is considered valid.

APPLICATION INFORMATION

The UCC2946 supervisory circuit provides accurate reset and watchdog functions for a variety of microprocessor applications. The reset circuit prevents the microprocessor from executing code during undervoltage conditions, typically during power-up and power-down. To prevent erratic operation in the presence of noise, voltage glitches where voltage amplitude and time duration are less than the values specified in [Figure 1](#) are ignored.

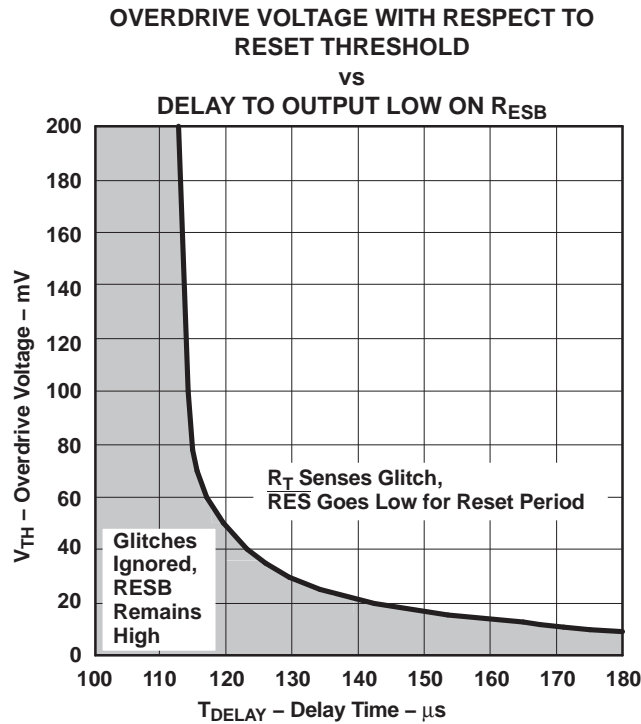

Figure 1.

The watchdog circuit monitors the microprocessor's activity, if the microprocessor does not toggle WDI during the programmable watchdog period WDO goes low, alerting the microprocessor's interrupt of a fault. The WDO pin is typically connected to the non-maskable input of the microprocessor so that an error recovery routine can be executed.

Programming the Reset Voltage and Reset Period

The UCC2946 allows the reset trip voltage to be programmed with two external resistors. In most applications, VDD is monitored by the reset circuit, however, the design allows voltages other than VDD to be monitored. Referring to Figure 2, the voltage below which reset is asserted is determined by Equation 1:

$$V_{\text{RESET}} = 1.235 \times \left(\frac{R1 + R2}{R2} \right) \tag{1}$$

To keep quiescent currents low, resistor values in the MΩ range can be used for R1 and R2. A manual reset can be easily implemented by connecting a momentary push switch in parallel with R2. $\overline{\text{RES}}$ is ensured to be low with VDD voltages as low as 1 V.

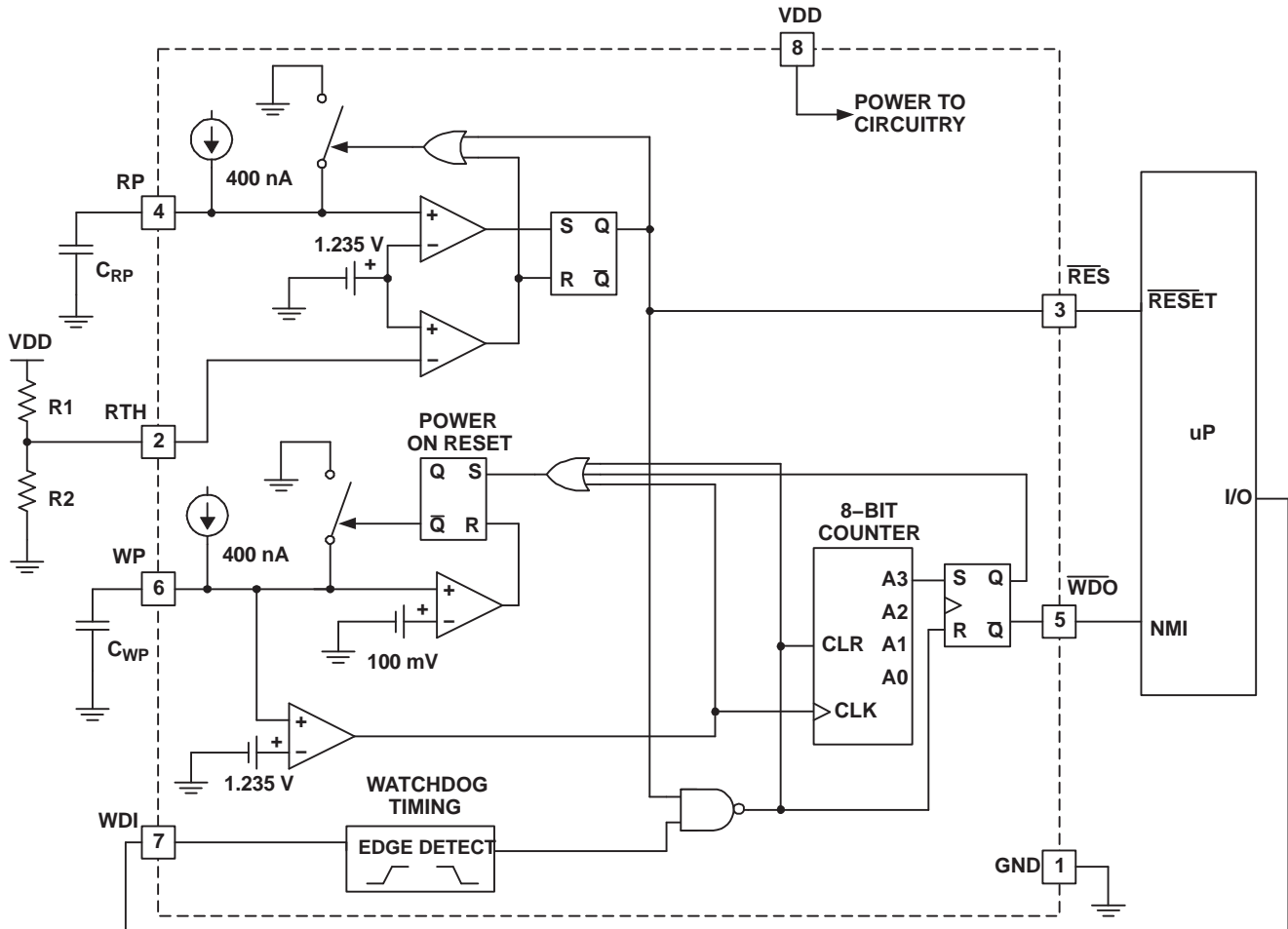

UDG-98002

Figure 2. Typical Application Diagram

Once VDD rises above the programmed threshold, $\overline{\text{RES}}$ remains low for the reset period defined by Equation 2:

$$T_{\text{RP}} = 3.125 \times C_{\text{RP}} \tag{2}$$

Where

T_{RP} is time in milliseconds

C_{RP} is capacitance in nanofarads

C_{RP} is charged with a precision current source of 400 nA, a high-quality, low-leakage capacitor (such as an NPO ceramic) should be used to maintain timing tolerances. Figure 3 shows the voltage levels and timings associated with the reset circuit.

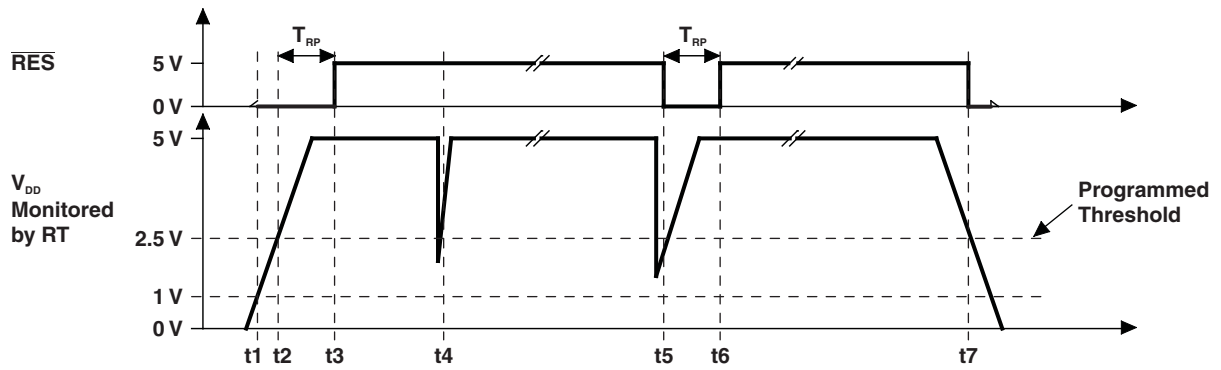

- t1: $V_{DD} > 1\text{ V}$, \overline{RES} is ensured low.
- t2: $V_{DD} >$ programmed threshold, \overline{RES} remains low for T_{RP} .
- t3: T_{RP} expires, \overline{RES} pulls high.
- t4: Voltage glitch occurs, but is filtered at the RTH pin, \overline{RES} remains high.
- t5: Voltage glitch occurs whose magnitude and duration is greater than the RTH filter, \overline{RES} is asserted for T_{RP} .
- t6: On completion of the T_{RP} pulse the RTH voltage has returned and \overline{RES} is pulled high.
- t7: V_{DD} dips below threshold (minus hysteresis), \overline{RES} is asserted.

Figure 3. Reset Circuit Timings

Programming the Watchdog Period

The watchdog period is programmed with C_{WP} as shown in Equation 3:

$$T_{WP} = 25 \times C_{WP} \quad (3)$$

Where

T_{WP} is in milliseconds

C_{WP} is in nanofarads

A high-quality, low-leakage capacitor should be used for C_{WP} . The watchdog input WDI must be toggled with a high-to-low or low-to-high transition within the watchdog period to prevent \overline{WDO} from assuming a logic level low. \overline{WDO} maintains the low logic level until WDI is toggled or RES is asserted. If at any time RES is asserted, \overline{WDO} assumes a high logic state and the watchdog period be reinitiated. Figure 4 shows the timings associated with the watchdog circuit.

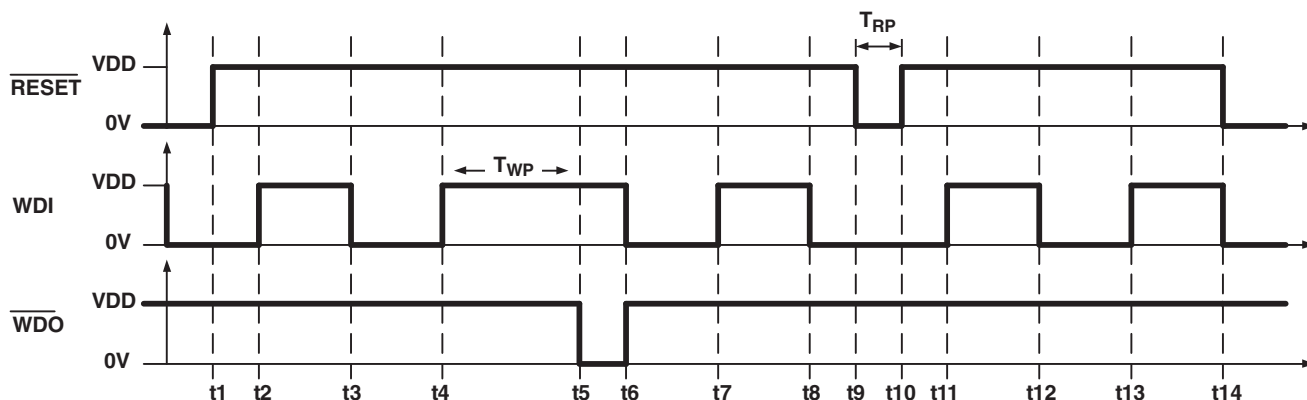

- t1: Microprocessor is reset.
- t2: WDI is toggled some time after reset, but before T_{WP} expires.
- t3: WDI is toggled before T_{WP} expires.
- t4: WDI is toggled before T_{WP} expires.
- t5: WDI is not toggled before T_{WP} expires and \overline{WDO} asserts low, triggering the microprocessor to enter an error recovery routine.
- t6: The microprocessor's error recovery routine is executed and WDI is toggled, reinitiating the watchdog timer.
- t7: WDI is toggled before T_{WP} expires.
- t8: WDI is toggled before T_{WP} expires.
- t9: RES is momentarily triggered, \overline{RES} is asserted low for T_{RP} .
- t10: Microprocessor is reset, \overline{RES} pulls high.
- t11: WDI is toggled some time after reset, but before T_{WP} expires.
- t12: WDI is toggled before T_{WP} expires.

Figure 4. Watchdog Circuit Timing

Connecting \overline{WDO} to \overline{RES}

To provide design flexibility, the reset and watchdog circuits in the UCC2946 have separate outputs. Each output independently drives high or low, depending on circuit conditions explained previously.

In some applications, it may be desirable for either the \overline{RES} or \overline{WDO} to reset the microprocessor. This can be done by connecting \overline{WDO} to \overline{RES} . If the pins try to drive to different output levels, the low output level dominates. Additional current flows from VDD to GND during these states. If the application cannot support additional current (during fault conditions), \overline{RES} and \overline{WDO} can be connected to the inputs of an OR gate whose output is connected to the microprocessor's reset pin.

Layout Considerations

A 0.1- μ F capacitor connected from VDD to GND is recommended to decouple the UCC2946 from switching transients on the VDD supply rail.

Because RP and WP are precision current sources, capacitors C_{RP} and C_{WP} should be connected to these pins with minimal trace length to reduce board capacitance. Care should be taken to route any traces with high voltage potential or high speed digital signals away from these capacitors.

Resistors $R1$ and $R2$ generally have a high ohmic value; traces associated with these parts should be kept short to prevent any transient producing signals from coupling into the high-impedance RTH pin.

TYPICAL CHARACTERISTICS

THRESHOLD RESISTANCE
vs
AMBIENT TEMPERATURE

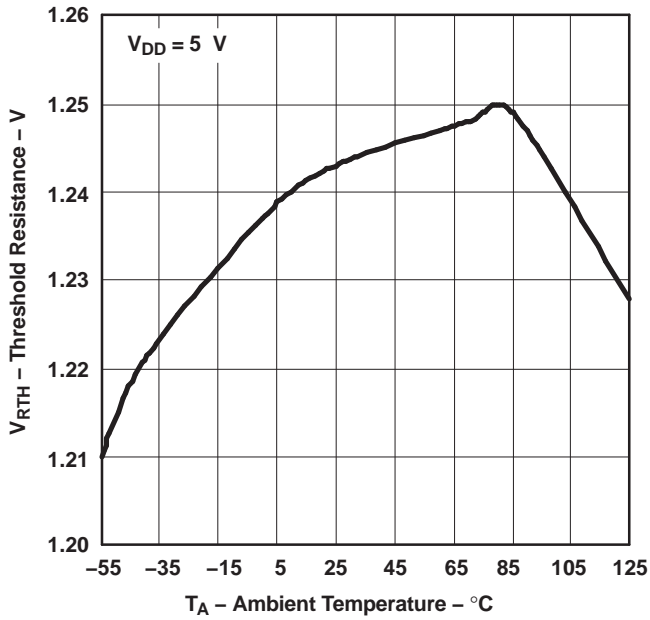

Figure 5.

INPUT CURRENT
vs
INPUT VOLTAGE

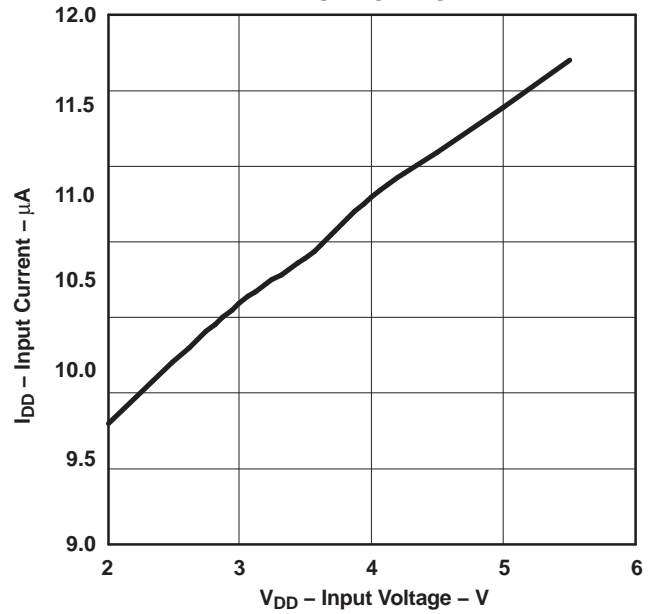

Figure 6.

PACKAGING INFORMATION

Orderable Device	Status ⁽¹⁾	Package Type	Package Drawing	Pins	Package Qty	Eco Plan ⁽²⁾	Lead/Ball Finish	MSL Peak Temp ⁽³⁾
UCC2946TPWRQ1	ACTIVE	TSSOP	PW	8	2000	Pb-Free (RoHS)	CU NIPDAU	Level-2-260C-1 YEAR

⁽¹⁾ The marketing status values are defined as follows:

ACTIVE: Product device recommended for new designs.

LIFEBUY: TI has announced that the device will be discontinued, and a lifetime-buy period is in effect.

NRND: Not recommended for new designs. Device is in production to support existing customers, but TI does not recommend using this part in a new design.

PREVIEW: Device has been announced but is not in production. Samples may or may not be available.

OBSOLETE: TI has discontinued the production of the device.

⁽²⁾ Eco Plan - The planned eco-friendly classification: Pb-Free (RoHS), Pb-Free (RoHS Exempt), or Green (RoHS & no Sb/Br) - please check <http://www.ti.com/productcontent> for the latest availability information and additional product content details.

TBD: The Pb-Free/Green conversion plan has not been defined.

Pb-Free (RoHS): TI's terms "Lead-Free" or "Pb-Free" mean semiconductor products that are compatible with the current RoHS requirements for all 6 substances, including the requirement that lead not exceed 0.1% by weight in homogeneous materials. Where designed to be soldered at high temperatures, TI Pb-Free products are suitable for use in specified lead-free processes.

Pb-Free (RoHS Exempt): This component has a RoHS exemption for either 1) lead-based flip-chip solder bumps used between the die and package, or 2) lead-based die adhesive used between the die and leadframe. The component is otherwise considered Pb-Free (RoHS compatible) as defined above.

Green (RoHS & no Sb/Br): TI defines "Green" to mean Pb-Free (RoHS compatible), and free of Bromine (Br) and Antimony (Sb) based flame retardants (Br or Sb do not exceed 0.1% by weight in homogeneous material)

⁽³⁾ MSL, Peak Temp. -- The Moisture Sensitivity Level rating according to the JEDEC industry standard classifications, and peak solder temperature.

Important Information and Disclaimer:The information provided on this page represents TI's knowledge and belief as of the date that it is provided. TI bases its knowledge and belief on information provided by third parties, and makes no representation or warranty as to the accuracy of such information. Efforts are underway to better integrate information from third parties. TI has taken and continues to take reasonable steps to provide representative and accurate information but may not have conducted destructive testing or chemical analysis on incoming materials and chemicals. TI and TI suppliers consider certain information to be proprietary, and thus CAS numbers and other limited information may not be available for release.

In no event shall TI's liability arising out of such information exceed the total purchase price of the TI part(s) at issue in this document sold by TI to Customer on an annual basis.

OTHER QUALIFIED VERSIONS OF UCC2946-Q1 :

- Catalog: [UCC2946](#)

NOTE: Qualified Version Definitions:

- Catalog - TI's standard catalog product

PW (R-PDSO-G**)

PLASTIC SMALL-OUTLINE PACKAGE

14 PINS SHOWN

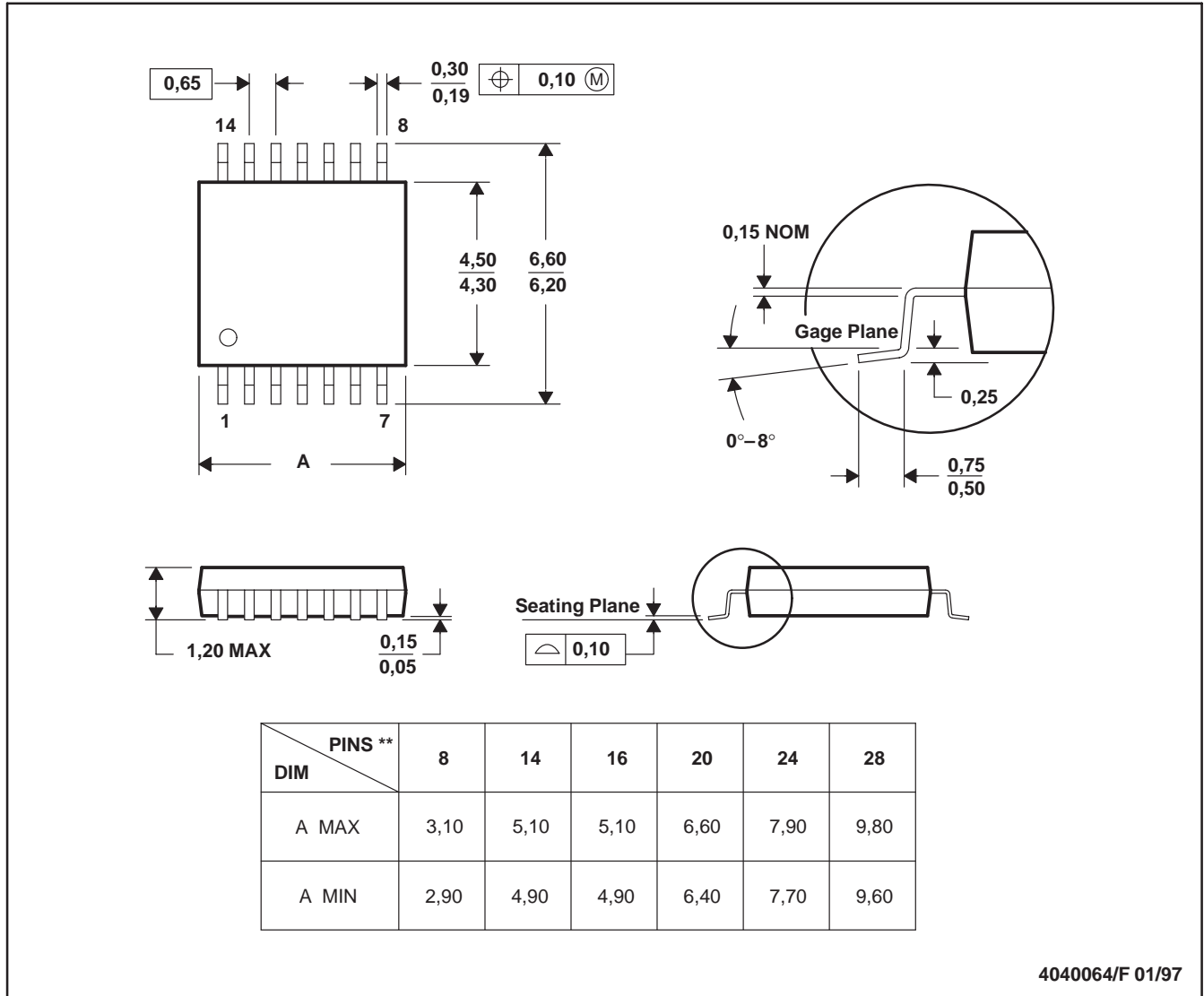

4040064/F 01/97

- NOTES: A. All linear dimensions are in millimeters.
 B. This drawing is subject to change without notice.
 C. Body dimensions do not include mold flash or protrusion not to exceed 0,15.
 D. Falls within JEDEC MO-153

IMPORTANT NOTICE

Texas Instruments Incorporated and its subsidiaries (TI) reserve the right to make corrections, modifications, enhancements, improvements, and other changes to its products and services at any time and to discontinue any product or service without notice. Customers should obtain the latest relevant information before placing orders and should verify that such information is current and complete. All products are sold subject to TI's terms and conditions of sale supplied at the time of order acknowledgment.

TI warrants performance of its hardware products to the specifications applicable at the time of sale in accordance with TI's standard warranty. Testing and other quality control techniques are used to the extent TI deems necessary to support this warranty. Except where mandated by government requirements, testing of all parameters of each product is not necessarily performed.

TI assumes no liability for applications assistance or customer product design. Customers are responsible for their products and applications using TI components. To minimize the risks associated with customer products and applications, customers should provide adequate design and operating safeguards.

TI does not warrant or represent that any license, either express or implied, is granted under any TI patent right, copyright, mask work right, or other TI intellectual property right relating to any combination, machine, or process in which TI products or services are used. Information published by TI regarding third-party products or services does not constitute a license from TI to use such products or services or a warranty or endorsement thereof. Use of such information may require a license from a third party under the patents or other intellectual property of the third party, or a license from TI under the patents or other intellectual property of TI.

Reproduction of TI information in TI data books or data sheets is permissible only if reproduction is without alteration and is accompanied by all associated warranties, conditions, limitations, and notices. Reproduction of this information with alteration is an unfair and deceptive business practice. TI is not responsible or liable for such altered documentation. Information of third parties may be subject to additional restrictions.

Resale of TI products or services with statements different from or beyond the parameters stated by TI for that product or service voids all express and any implied warranties for the associated TI product or service and is an unfair and deceptive business practice. TI is not responsible or liable for any such statements.

TI products are not authorized for use in safety-critical applications (such as life support) where a failure of the TI product would reasonably be expected to cause severe personal injury or death, unless officers of the parties have executed an agreement specifically governing such use. Buyers represent that they have all necessary expertise in the safety and regulatory ramifications of their applications, and acknowledge and agree that they are solely responsible for all legal, regulatory and safety-related requirements concerning their products and any use of TI products in such safety-critical applications, notwithstanding any applications-related information or support that may be provided by TI. Further, Buyers must fully indemnify TI and its representatives against any damages arising out of the use of TI products in such safety-critical applications.

TI products are neither designed nor intended for use in military/aerospace applications or environments unless the TI products are specifically designated by TI as military-grade or "enhanced plastic." Only products designated by TI as military-grade meet military specifications. Buyers acknowledge and agree that any such use of TI products which TI has not designated as military-grade is solely at the Buyer's risk, and that they are solely responsible for compliance with all legal and regulatory requirements in connection with such use.

TI products are neither designed nor intended for use in automotive applications or environments unless the specific TI products are designated by TI as compliant with ISO/TS 16949 requirements. Buyers acknowledge and agree that, if they use any non-designated products in automotive applications, TI will not be responsible for any failure to meet such requirements.

Following are URLs where you can obtain information on other Texas Instruments products and application solutions:

Products		Applications	
Amplifiers	amplifier.ti.com	Audio	www.ti.com/audio
Data Converters	dataconverter.ti.com	Automotive	www.ti.com/automotive
DLP® Products	www.dlp.com	Communications and Telecom	www.ti.com/communications
DSP	dsp.ti.com	Computers and Peripherals	www.ti.com/computers
Clocks and Timers	www.ti.com/clocks	Consumer Electronics	www.ti.com/consumer-apps
Interface	interface.ti.com	Energy	www.ti.com/energy
Logic	logic.ti.com	Industrial	www.ti.com/industrial
Power Mgmt	power.ti.com	Medical	www.ti.com/medical
Microcontrollers	microcontroller.ti.com	Security	www.ti.com/security
RFID	www.ti-rfid.com	Space, Avionics & Defense	www.ti.com/space-avionics-defense
RF/IF and ZigBee® Solutions	www.ti.com/lprf	Video and Imaging	www.ti.com/video
		Wireless	www.ti.com/wireless-apps

Mailing Address: Texas Instruments, Post Office Box 655303, Dallas, Texas 75265
Copyright © 2010, Texas Instruments Incorporated

www.BDTIC.com/TI